

STEP 7

- 7.1 Attach Drawer Slider (4B) to Keyboard Panel (C) using Screw (5), as shown.
- 7.2 Attach Keyboard Stopper (7) to Keyboard Panel (C) using Power Pin (8), as shown.

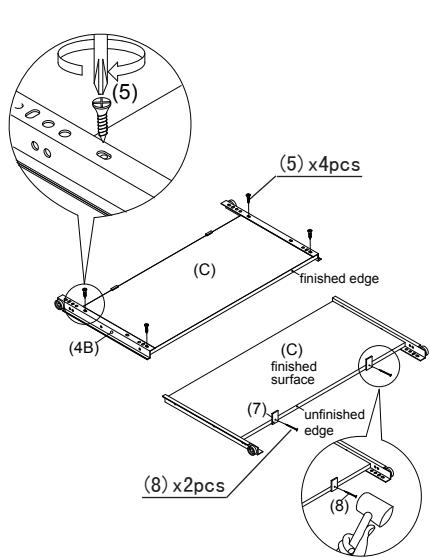

STEP 8

Slide Keyboard Panel (C) to the assembled unit, as shown:

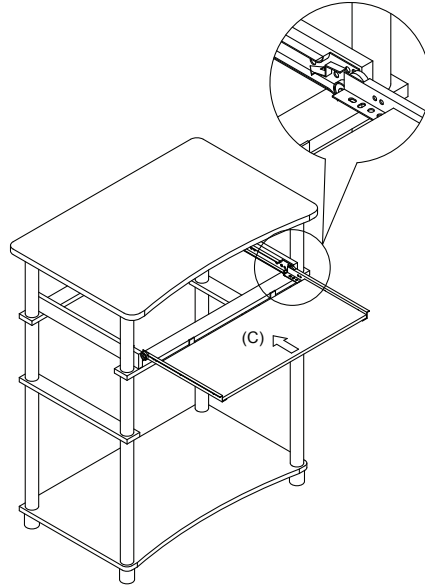

Recommended Maximum Weight

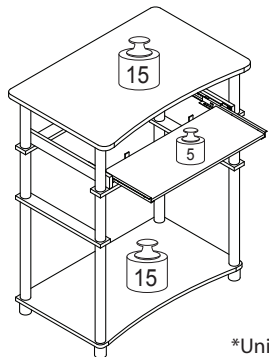

*Unit in Pound(lbs)

WARNING:

>This unit has been designed to support the maximum loads shown. Exceeding these load limits could cause sagging, instability, product collapse, and/or serious injury.

>DO NOT allow children to climb on unit.

>Put heavier items on lower shelves.

Assembly Instruction

Home Laptop Notebook
Computer Desk

00:30

Approx. 30 minutes





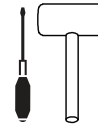



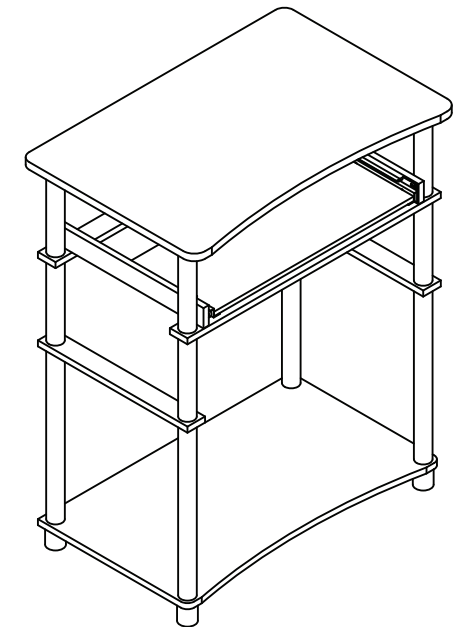



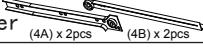

Recomm. 1 Person



Tools Required



| No | Hardware List | Qty |
|----|--|-------|
| 1 | Long Tube  | 4pcs |
| 2 | Short Tube  | 8pcs |
| 3 | Short Leg  | 4pcs |
| 4 | Drawer Slider  | 2sets |
| 5 | Short Screw  | 8pcs |
| 6 | Long Screw  | 4pcs |
| 7 | Keyboard Stopper  | 2pcs |
| 8 | Power Pin  | 2pcs |

| No | Parts List | Qty |
|----|--|------|
| A | Top Panel  | 1pcs |
| B | Bottom Panel  | 1pcs |
| C | Keyboard Panel  | 1pcs |
| D | L/R Slider Panel  | 2pcs |
| E | F/B Apron  | 2pcs |
| F | L/R Cross Bar  | 2pcs |

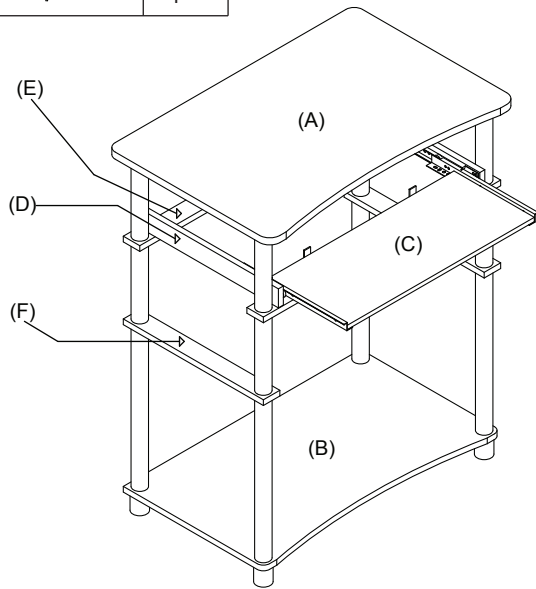

USEFUL HINTS BEFORE YOU START:

1. Read each step carefully before starting.
2. It is important that each step is performed in correct order to avoid difficulties.
3. Identify, sort and count the parts before assembly.
4. Assemble your furniture on packaging cardboard to prevent scratch or damage.
5. Clean the product with mild cleanser using soft damped cloth. Do not use harsh or abrasive cleanser.
6. Using incompatible hardware might cause damage to product.

STEP 1

Attach Short Pole(2) to insert cap and tighten it.

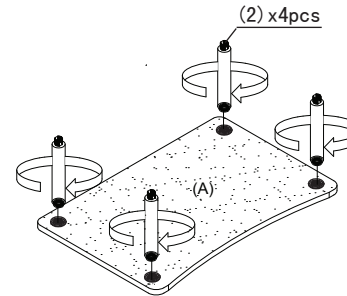

STEP 2

Attach Drawer Slider (4A) to L/R Slider Panel (D) using Screw (5), as shown.

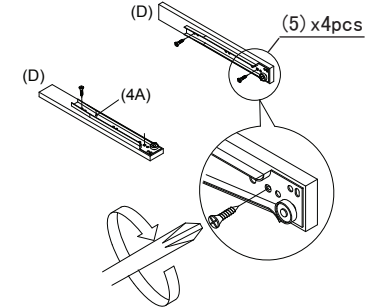

STEP 3

Attach F/B Apron Panel (E) to assembled parts from Step 2, using Long Screw (6), as shown.

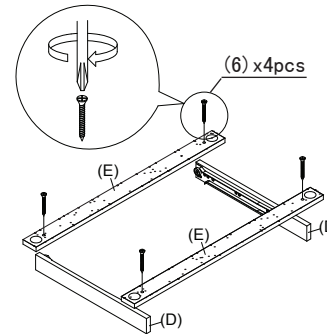

STEP 4

Attach Short Tube (2) to assembled parts from Step 1 & Step 3, as shown.

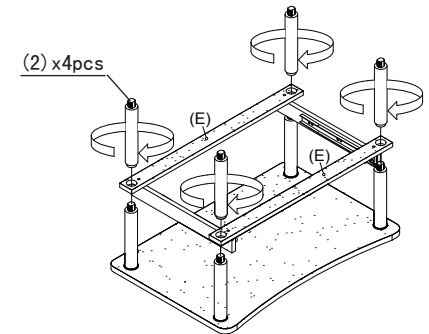

STEP 5

Attach L/R Panel (F) to assembled parts from Step 4, using Long Tube (1), as shown.

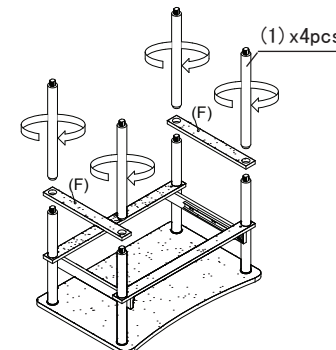

STEP 6

Attach Bottom Panel (B) to assembled parts from Step 5, using Short Leg (3), as shown.

