

CABINET

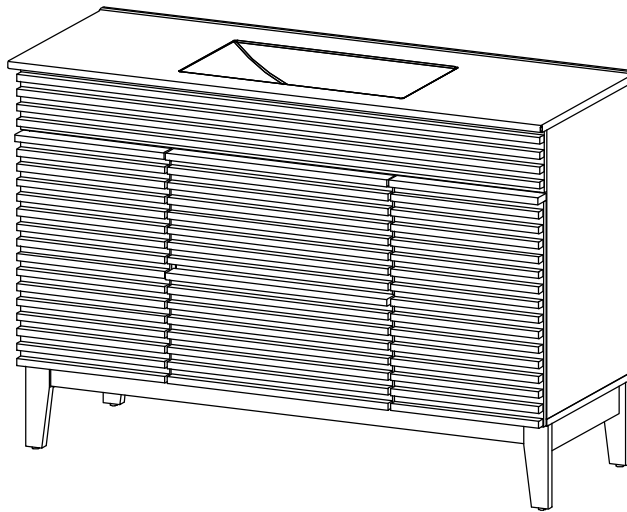









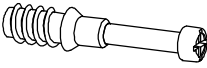

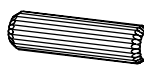
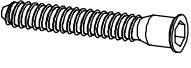





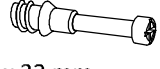

Thank you for purchasing the **CABINET !**

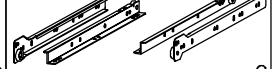
Before you start, here are some helpful advice:

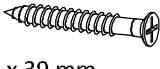
1. We suggest you spend a short time reading through this leaflet and then follow the simple step-by-step instructions.
2. Owing to the size and weight of the Cabinet, we recommend that it is assembled by two adults, on a carpeted or padded area, in the room that it is intended for. Approximate assembly time: 70 minutes.
3. Please do not use any tools other than those provided or recommended in these instructions.
4. Please do not throw away any of the packaging or instructions until you have checked all the components and hardware and the furniture is fully assembled.
5. Assemble all components loosely until advised to tighten. Depending on use, it may be necessary to tighten the components from time to time, so please save the tools that have been provided.
6. Please keep all pieces out of reach of children.

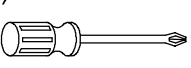
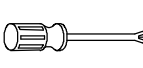

Hardware :

A) Cambolt Big/Metal  \varnothing 6 x 35 mm x 24	B) CamLock Big /Metal  \varnothing 15 mm x 26	C) Dowel Big /Wood  \varnothing 8x30 mm x 38	D) Screw/Metal  M 7 x 50 mm x 15	E) Hex/Allen Key/Metal  L 4 x 2
F) Hinge set/Metal  x 4	G) Screw/Metal  M 4.5 x 12.5 mm x 52	H) Shelf Support /Metal  x 8	I) Bracket/Metal  x 4	J) Bracket/Metal  x 2
K) Screw/Metal  M 6 x 10.5 mm x 22	L) Floor Protector/Sponge/Felt  25 x 15 x 2 mm x 10	M) Cambolt Small/Metal  \varnothing 6 x 32 mm x 14	N) CamLock Small /Metal  \varnothing 12 mm x 12	O) Rail/Metal  x 2
P) Screw/Metal  M 3.5 x 13 mm x 12	Q) Screw/Metal  M 8 x 39 mm x 16	R) Anti-Deflection Bar/Metal  x 1	S) Dowel Small /Wood  \varnothing 6x30 mm x 14	T) Bracket/Metal  x 2
U) Bracket/Metal  x 2	V) Screw/Metal  M 6 x 15 mm x 2	W) Screwdriver (Not Include)  x 1	X) Short Screwdriver (Not Include)  x 1	

CABINET

Components:

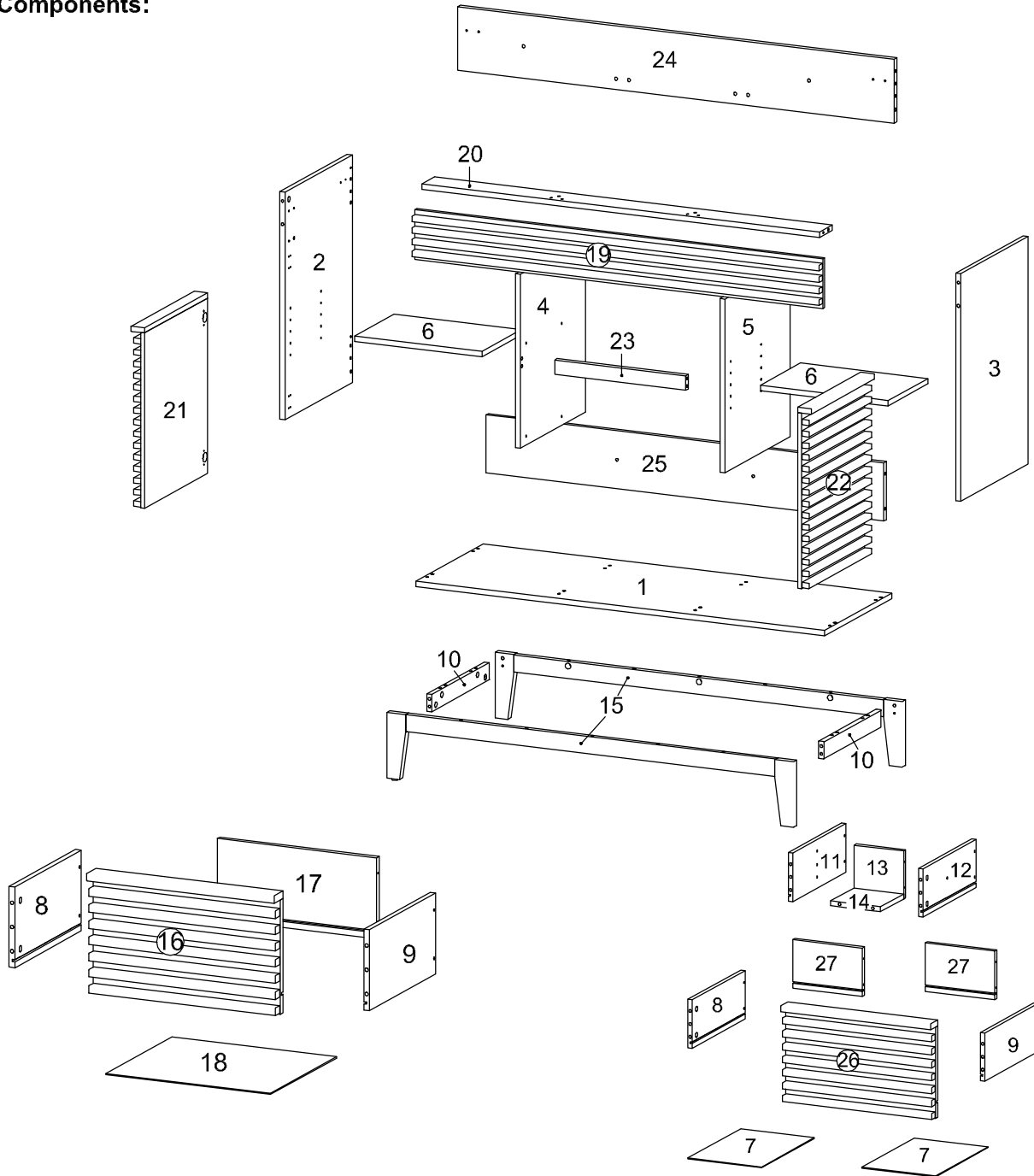

1 Bottom Board	x1	2 Side Board Left	x1	3 Side Board Right	x1	4 Center Board Left	x1
5 Center Board Right	x1	6 Adjustable Shelf	x2	7 Bottom Drawer Upper	x2	8 Side Drawer Left 1	x2
9 Side Drawer Right 1	x2	10 Support Leg	x2	11 Side Drawer Left 2	x1	12 Side Drawer Right 2	x1
13 Support Drawer 1	x1	14 Support Drawer 2	x1	15 Assembly Leg	x2	16 Front Drawer 1	x1
17 Back Drawer Lower	x1	18 Bottom Drawer Lower	x1	19 Front Skirt 1	x1	20 Support Board	x1
21 Frame Door Left	x1	22 Frame Door Right	x1	23 Front Skirt 2	x1	24 Back Skirt Upper	x1
25 Back Skirt Lower	x1	26 Front Drawer Upper	x1	27 Back Drawer Upper	x1		

CABINET

STEP 1:

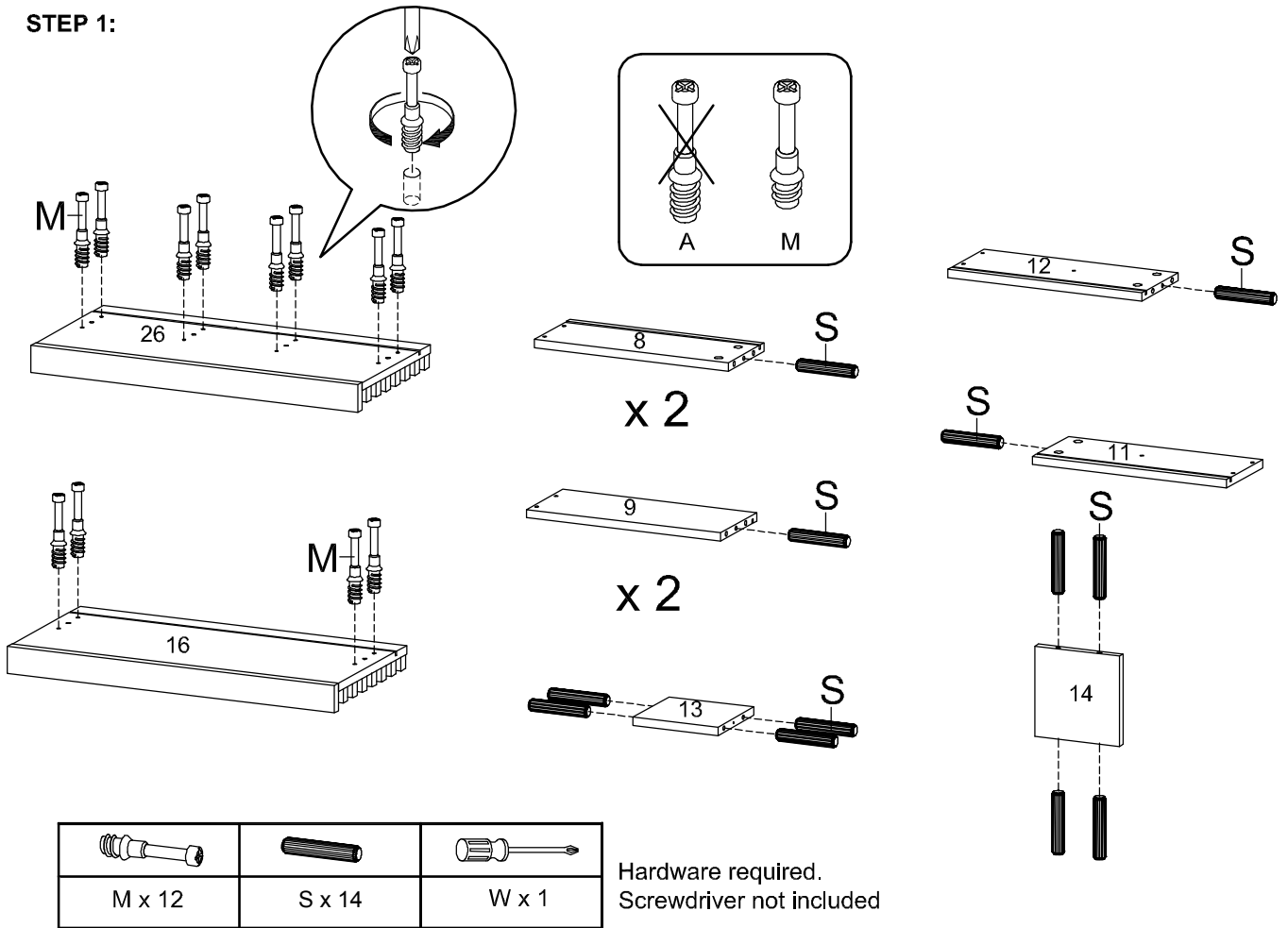

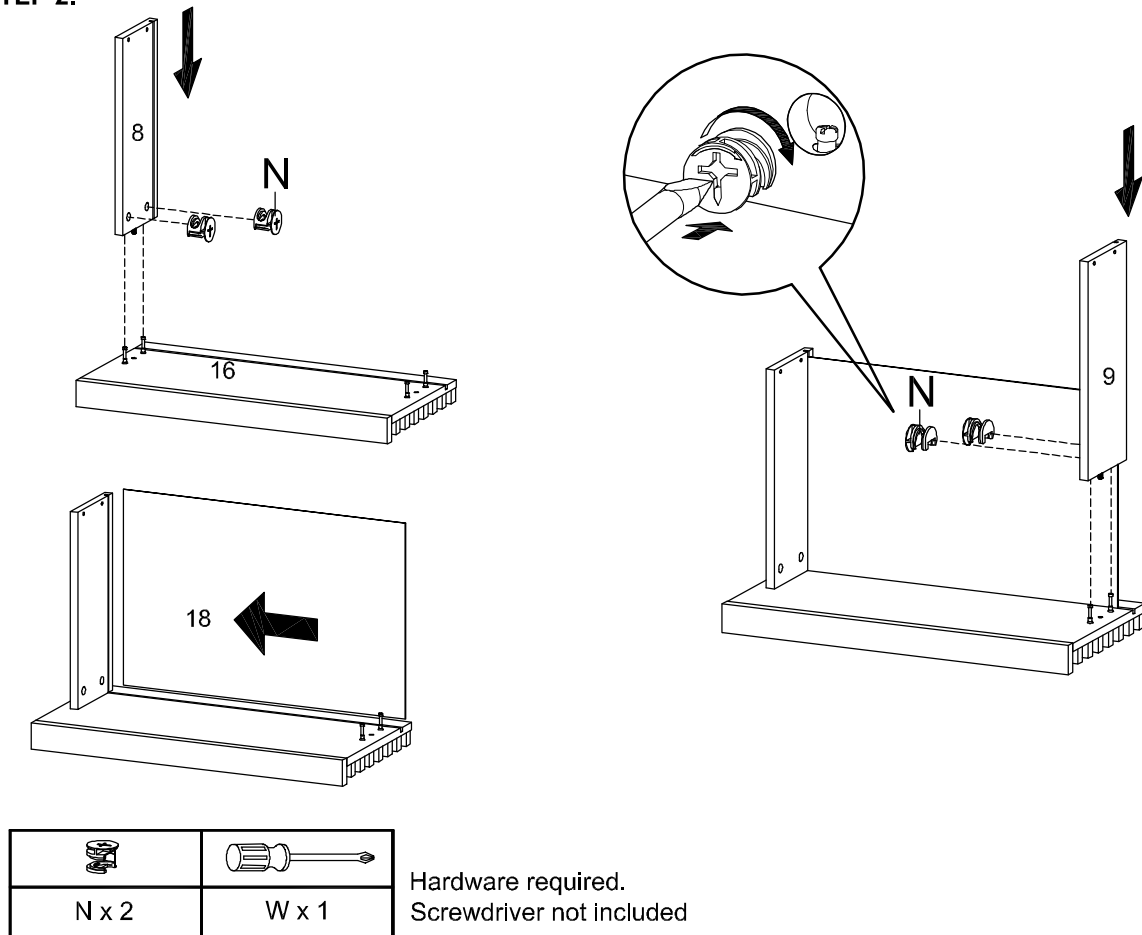

STEP 2:

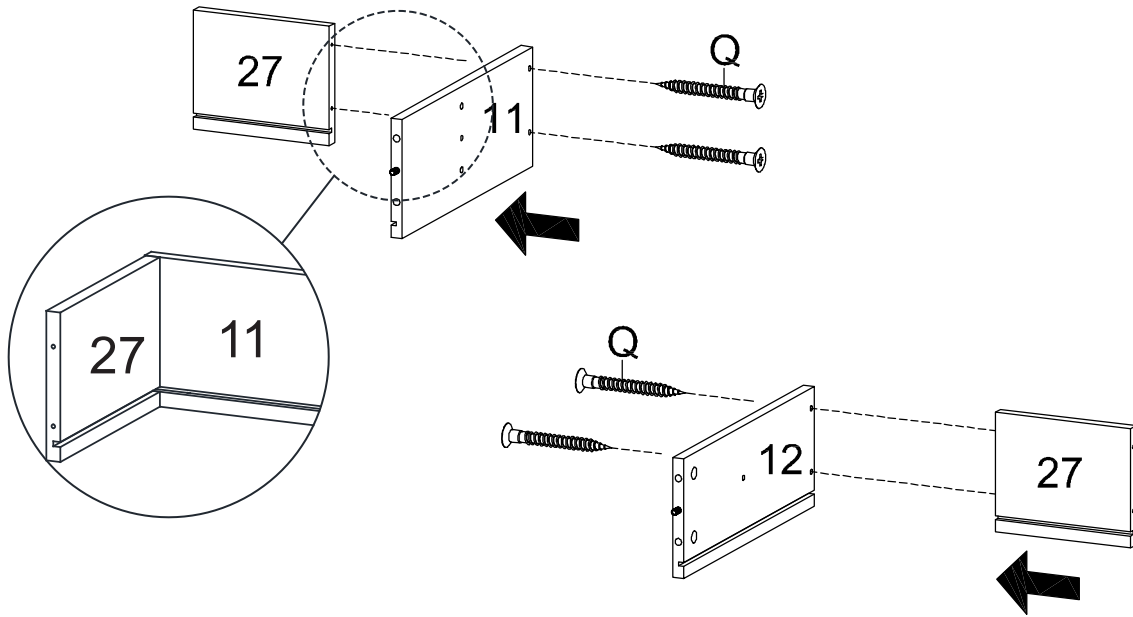

CABINET

STEP 3:

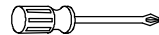

	
Q x 4	W x 1

Hardware required.
Screwdriver not included

STEP 4:

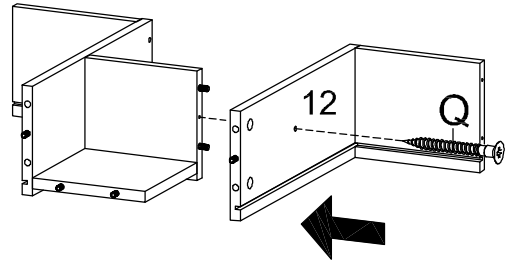
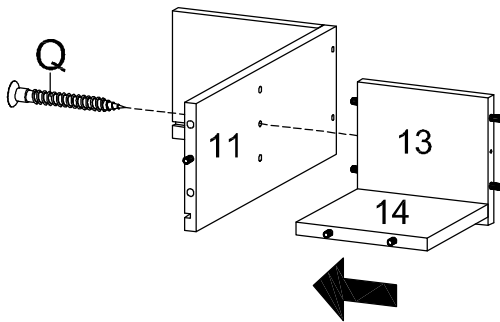
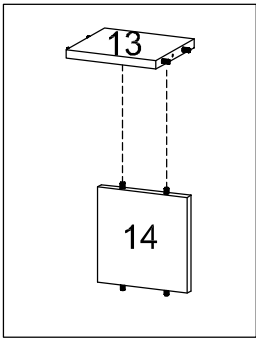

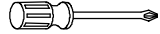
	
Q x 2	W x 1

Hardware required.
Screwdriver not included

CABINET

STEP 5:

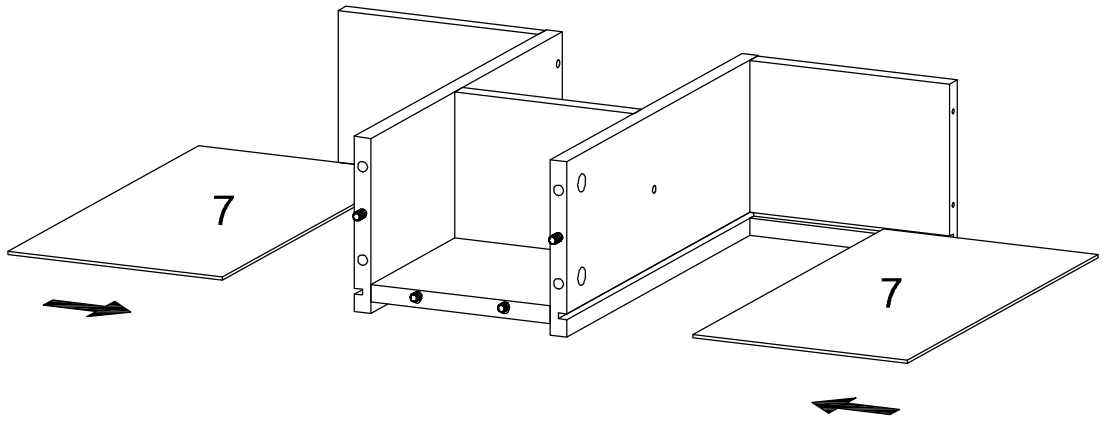

STEP 6:

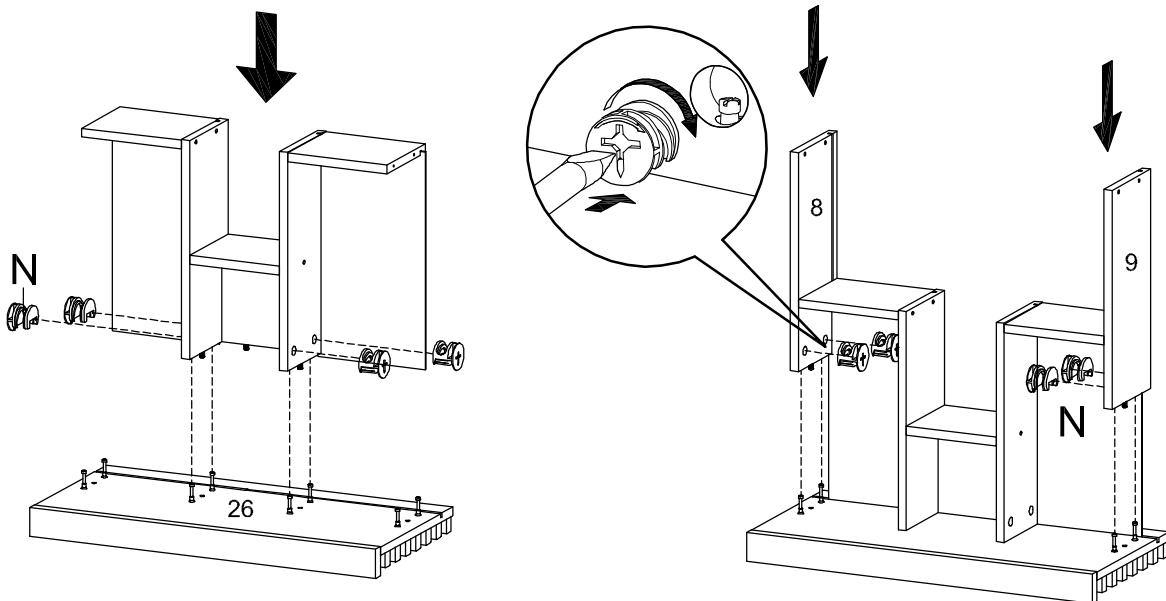

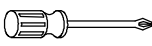

	
N x 8	X x 1

Hardware required.
Screwdriver not included

CABINET

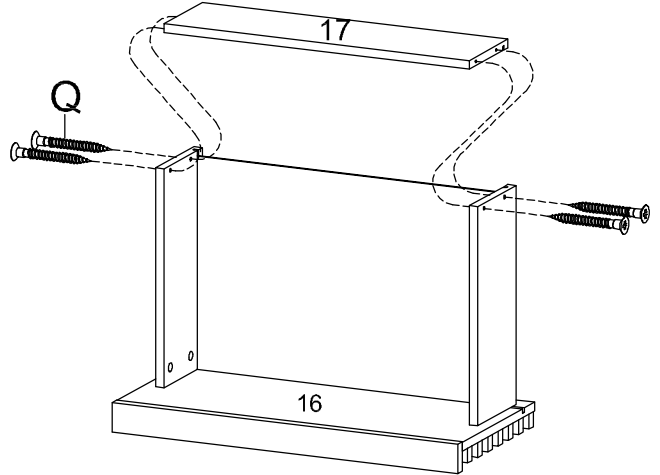
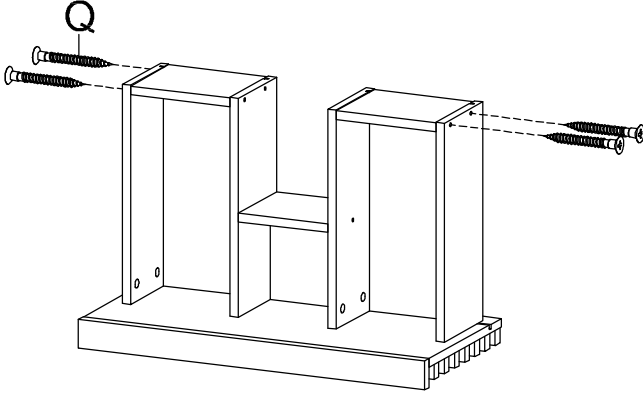
STEP 7:



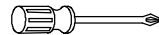

	
Q x 8	W x 1

Hardware required.
Screwdriver not included

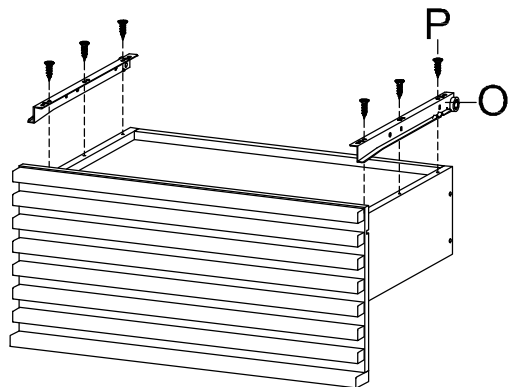
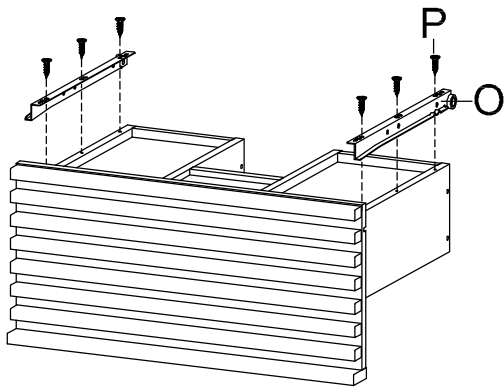
STEP 8:

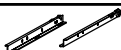





		
O x 2	P x 12	W x 1

Hardware required.
Screwdriver not included

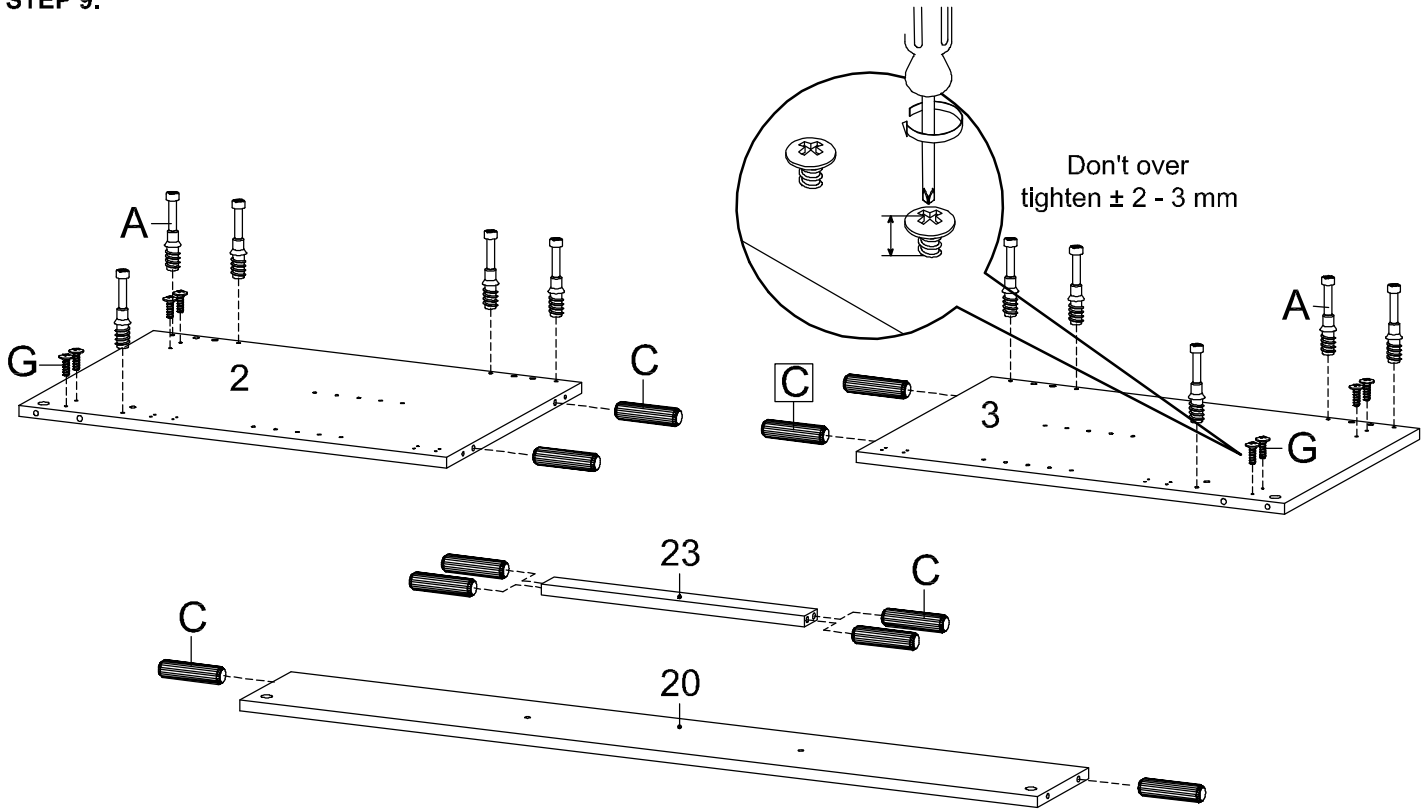
CABINET

STEP 9:



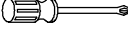

			
A x 10	C x 10	G x 8	W x 1

Hardware required.
Screwdriver not included

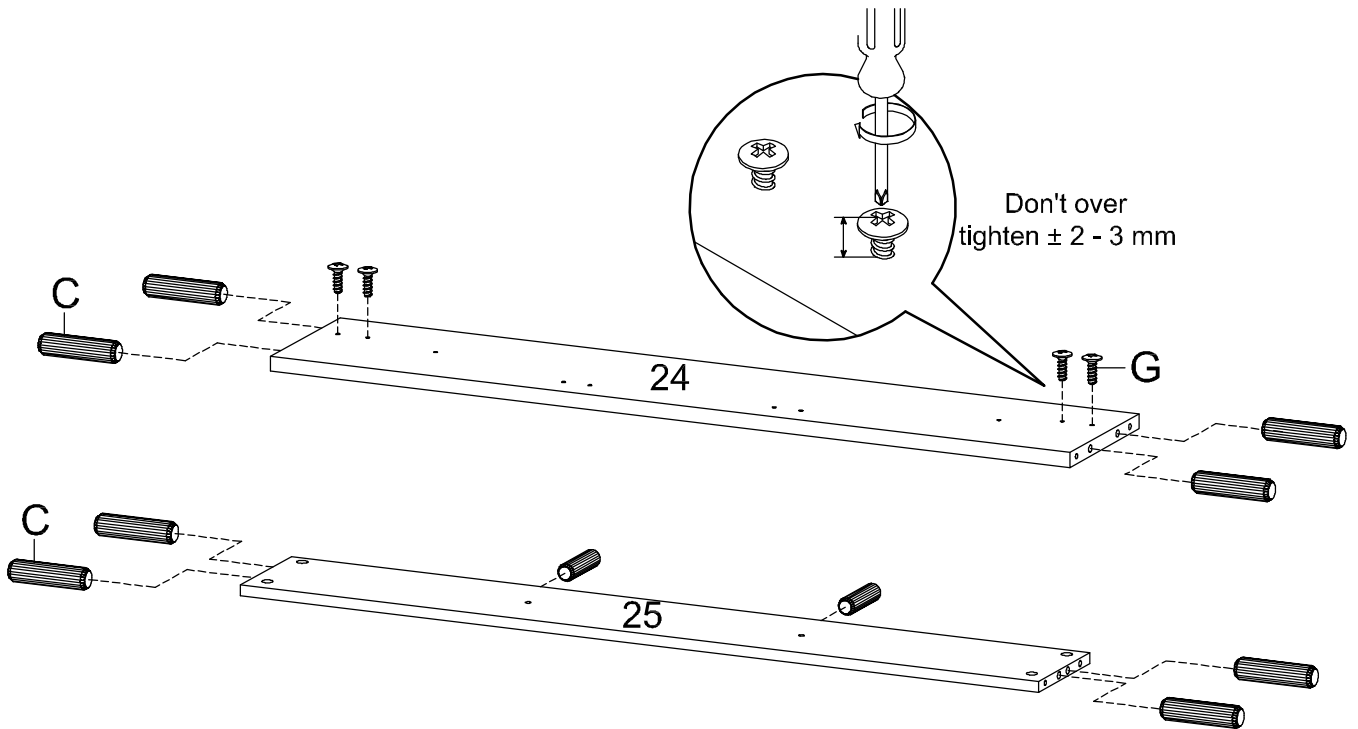
STEP 10:



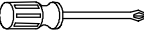



		
C x 10	G x 4	W x 1

Hardware required.
Screwdriver not included

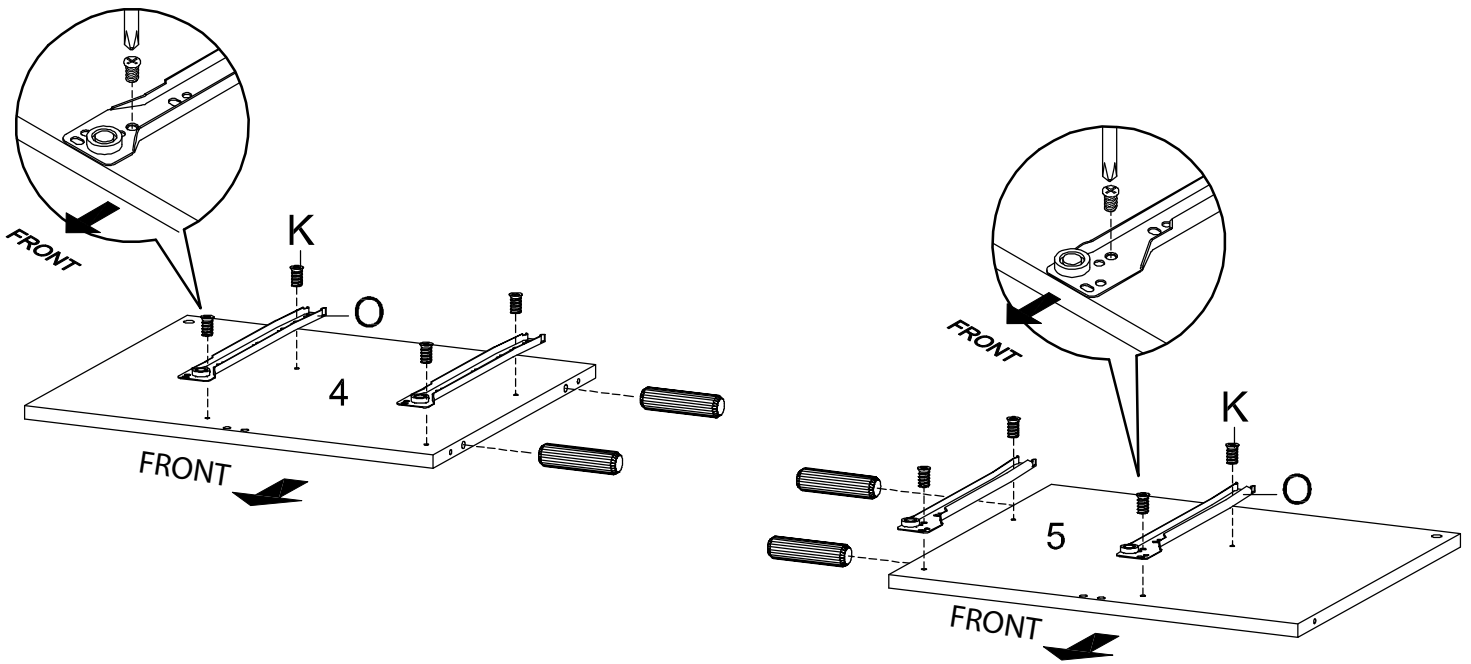
CABINET

STEP 11:

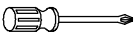

			
C x 4	K x 4	O x 2	W x 1

Hardware required.
Screwdriver not included

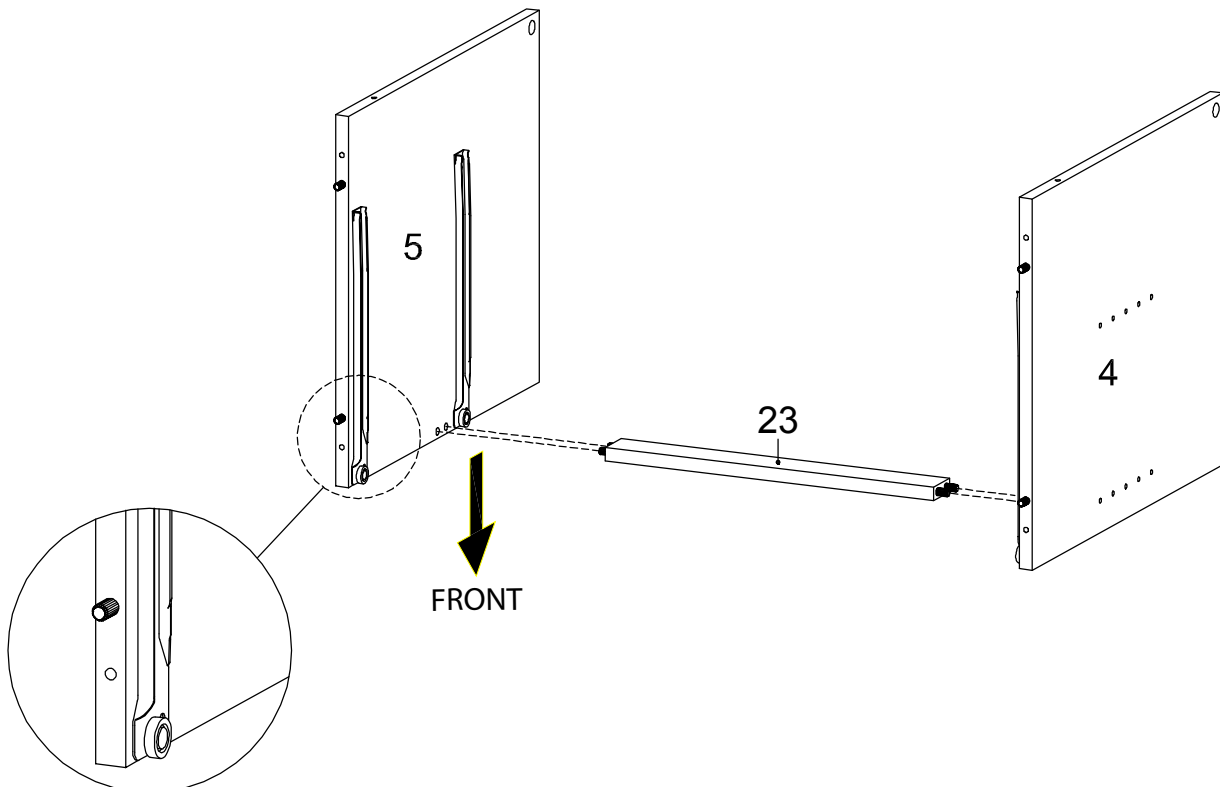

STEP 12:

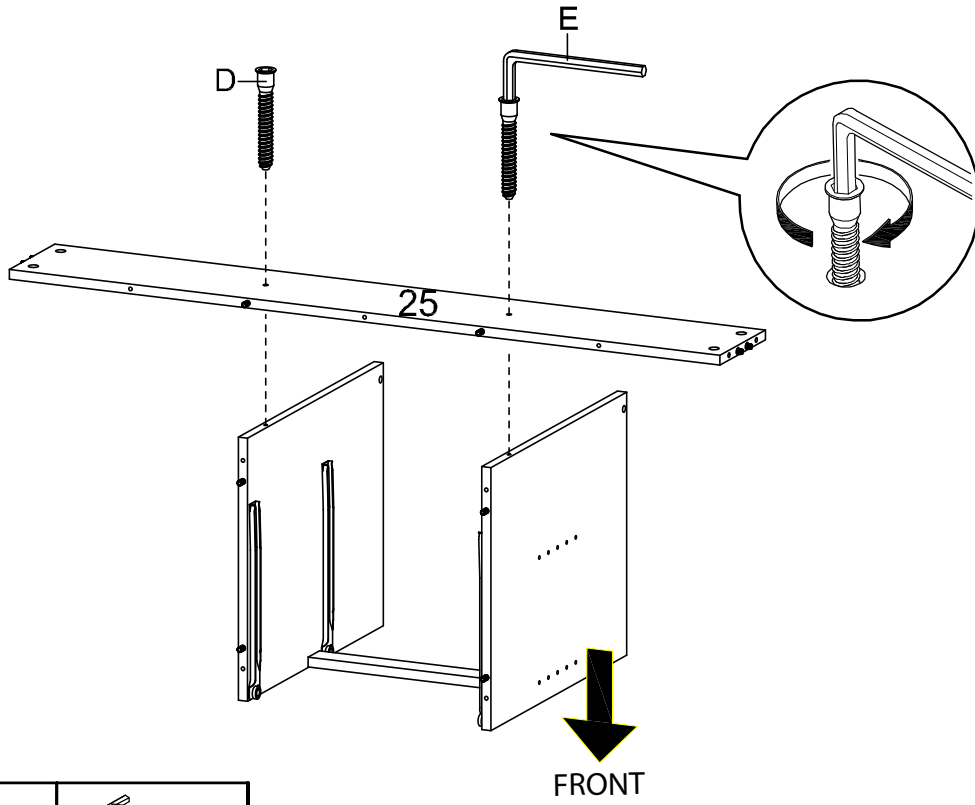

CABINET

STEP 13:





	
D x 2	E x 1

Hardware required.

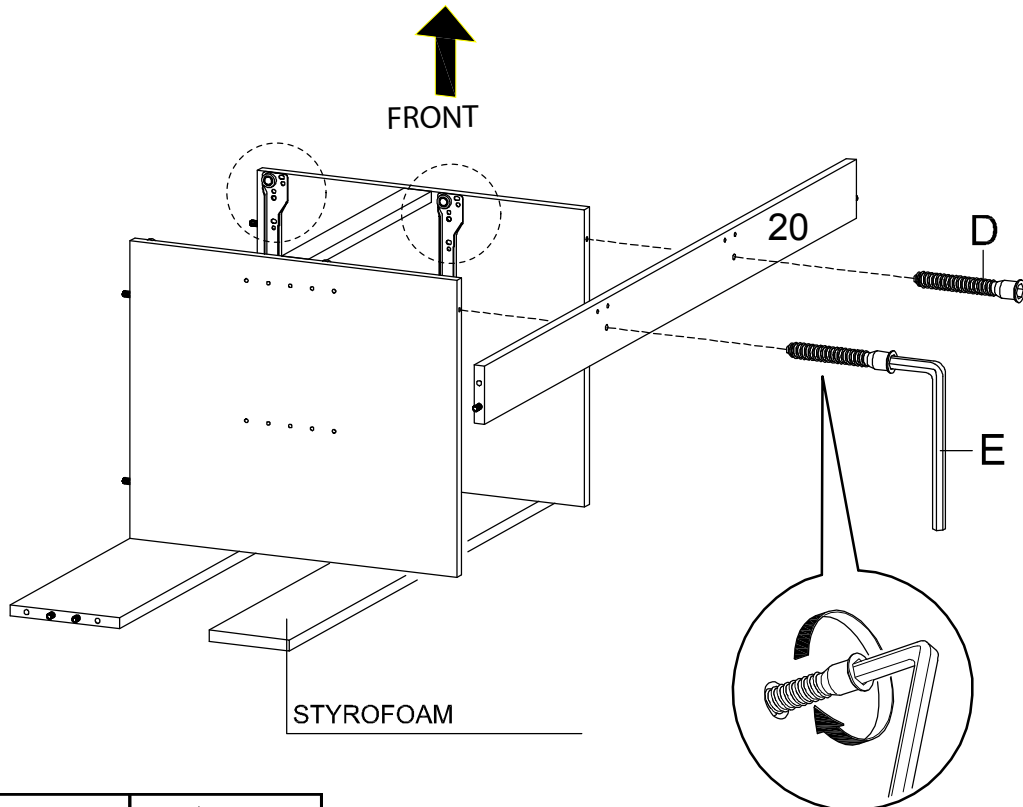
STEP 14:





	
D x 2	E

Hardware required.

CABINET

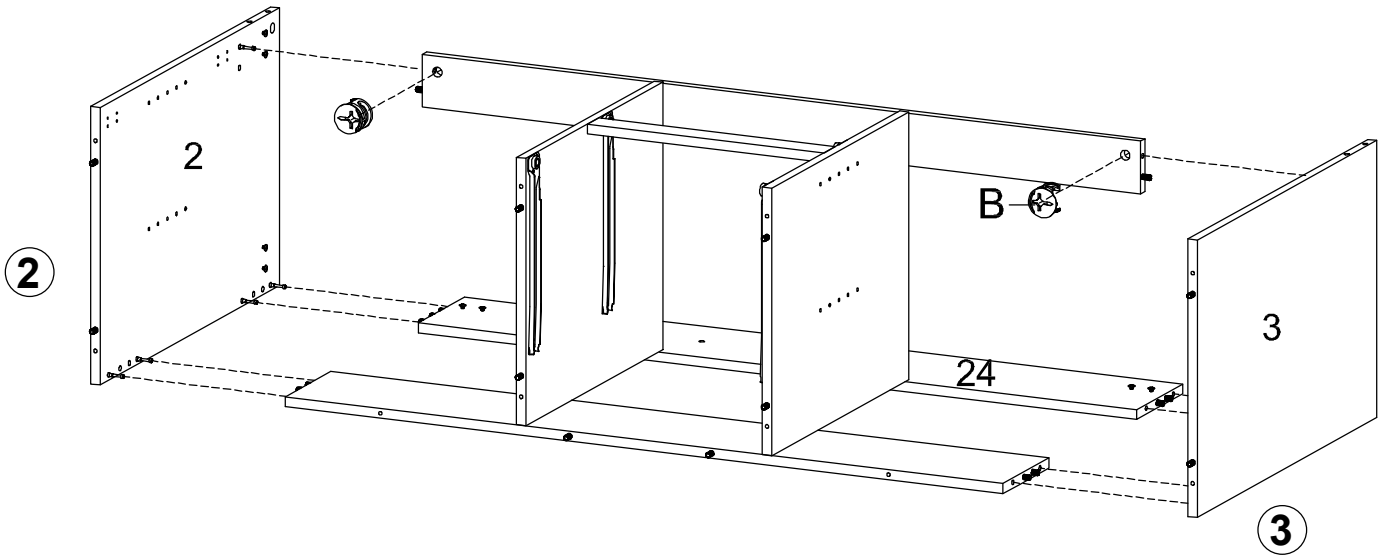
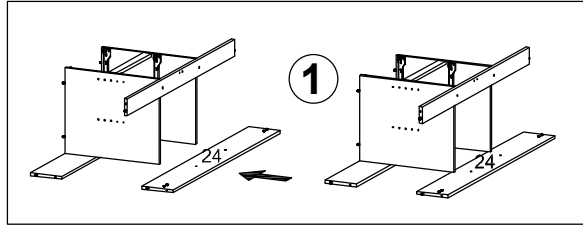
STEP 15:



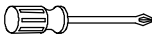

	
B x 2	W x 1

Hardware required.
Screwdriver not included

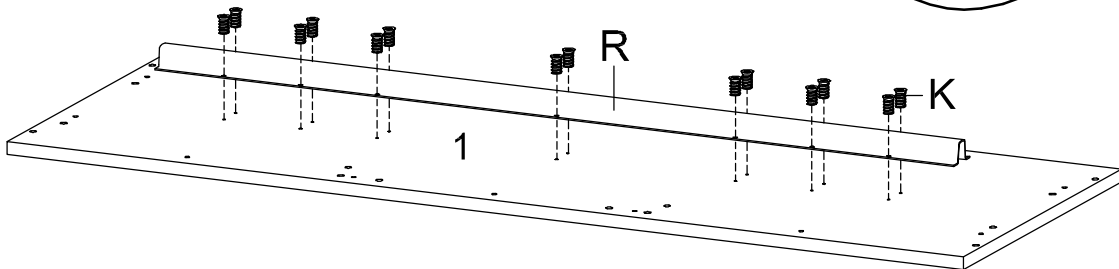
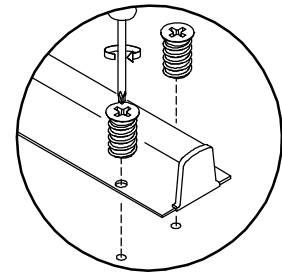
STEP 16:



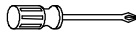

		
K x 14	R x 4	W x 1

Hardware required.
Screwdriver not included

CABINET

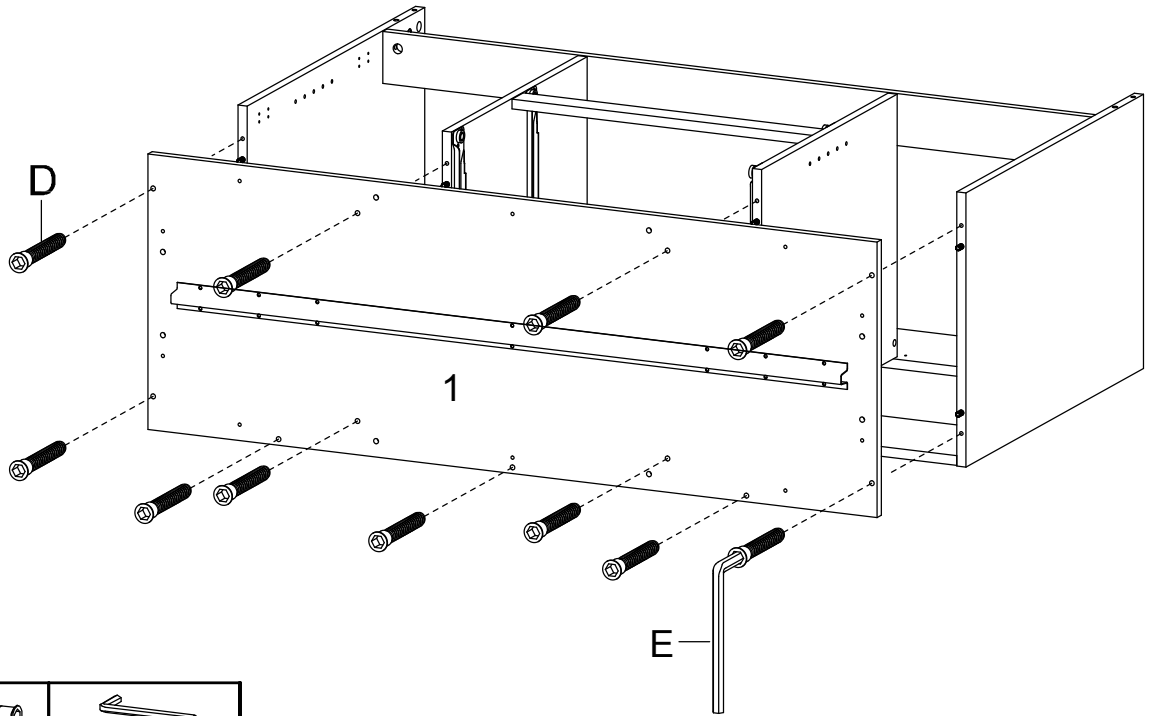
STEP 17:





	
D x 11	E

Hardware required.

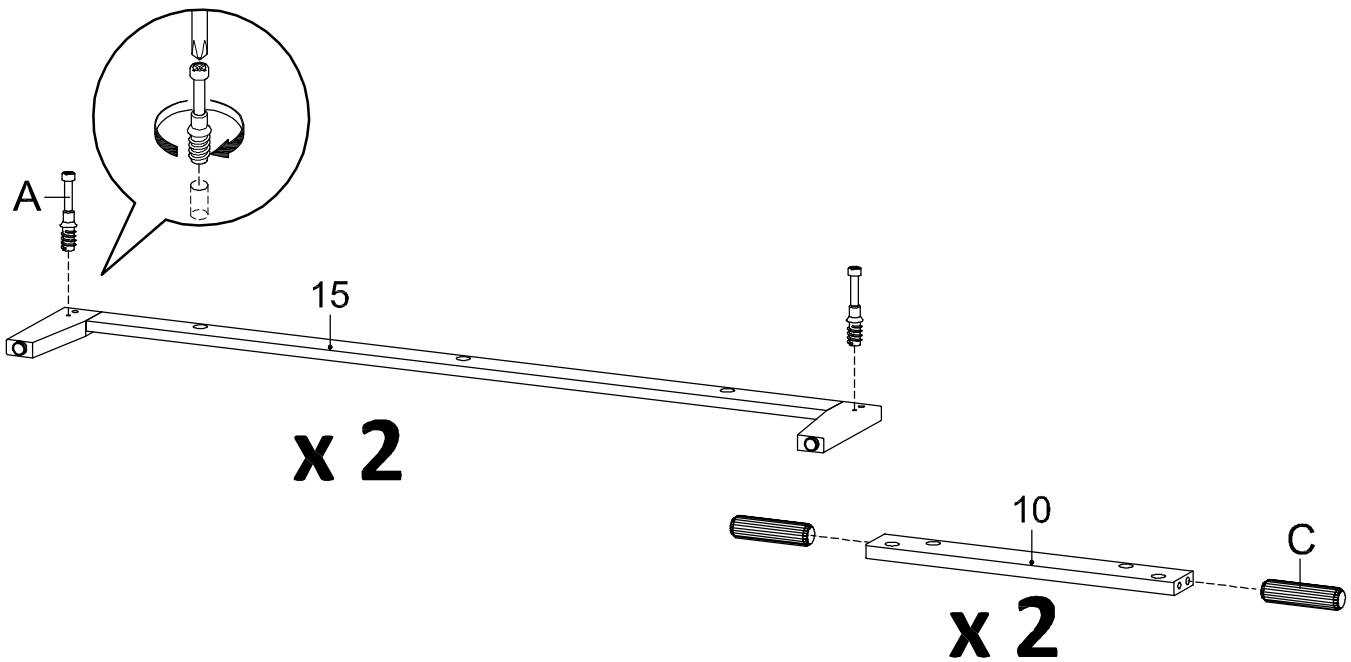
STEP 18:



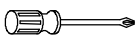

		
A x 4	C x 4	W x 1

Hardware required.
Screwdriver not included

CABINET

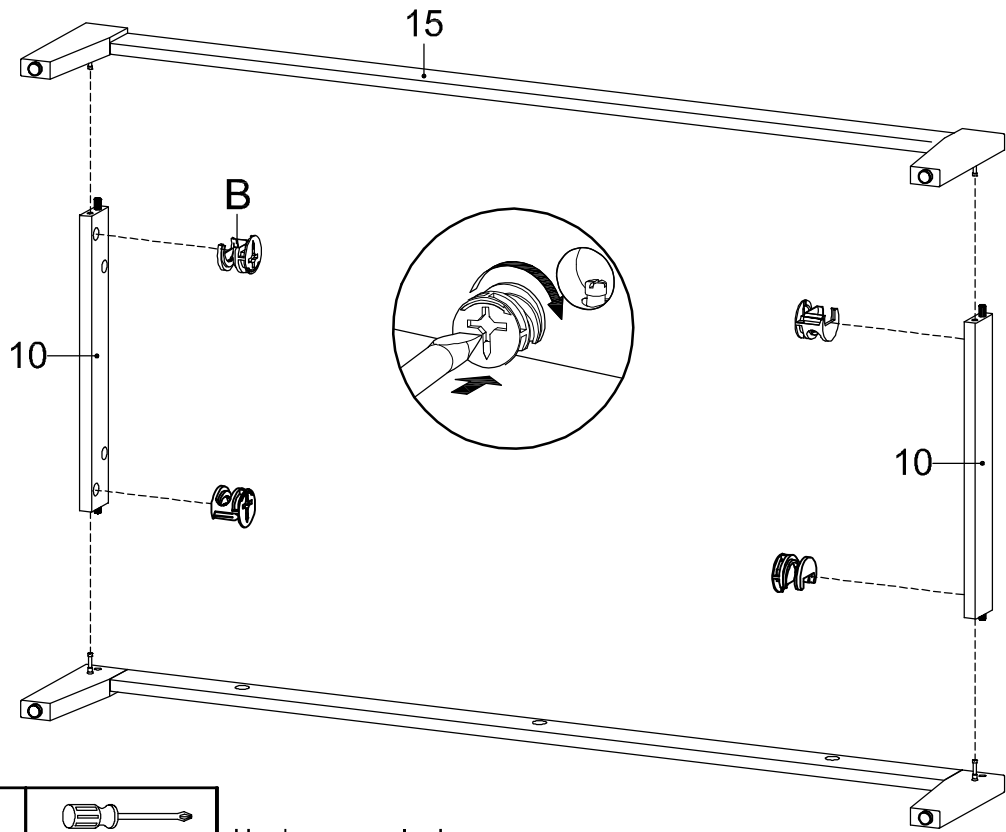
STEP 19:

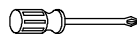

	
B x 4	W x 1

Hardware required.
Screwdriver not included

STEP 20:

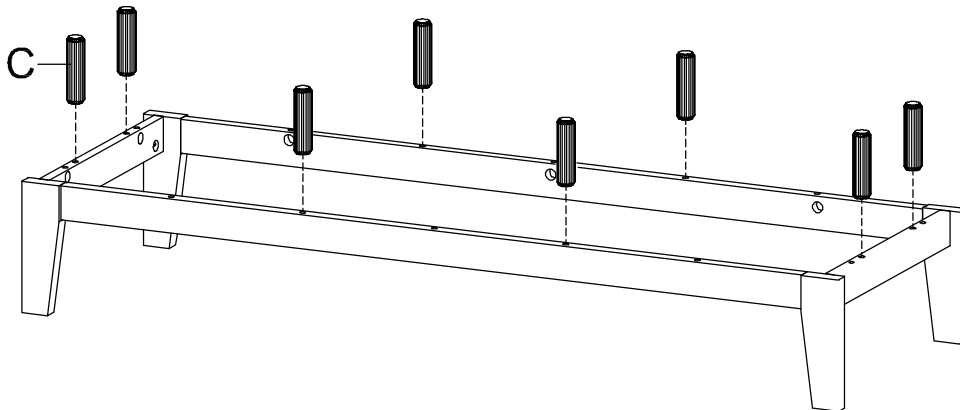





C x 8

Hardware required.

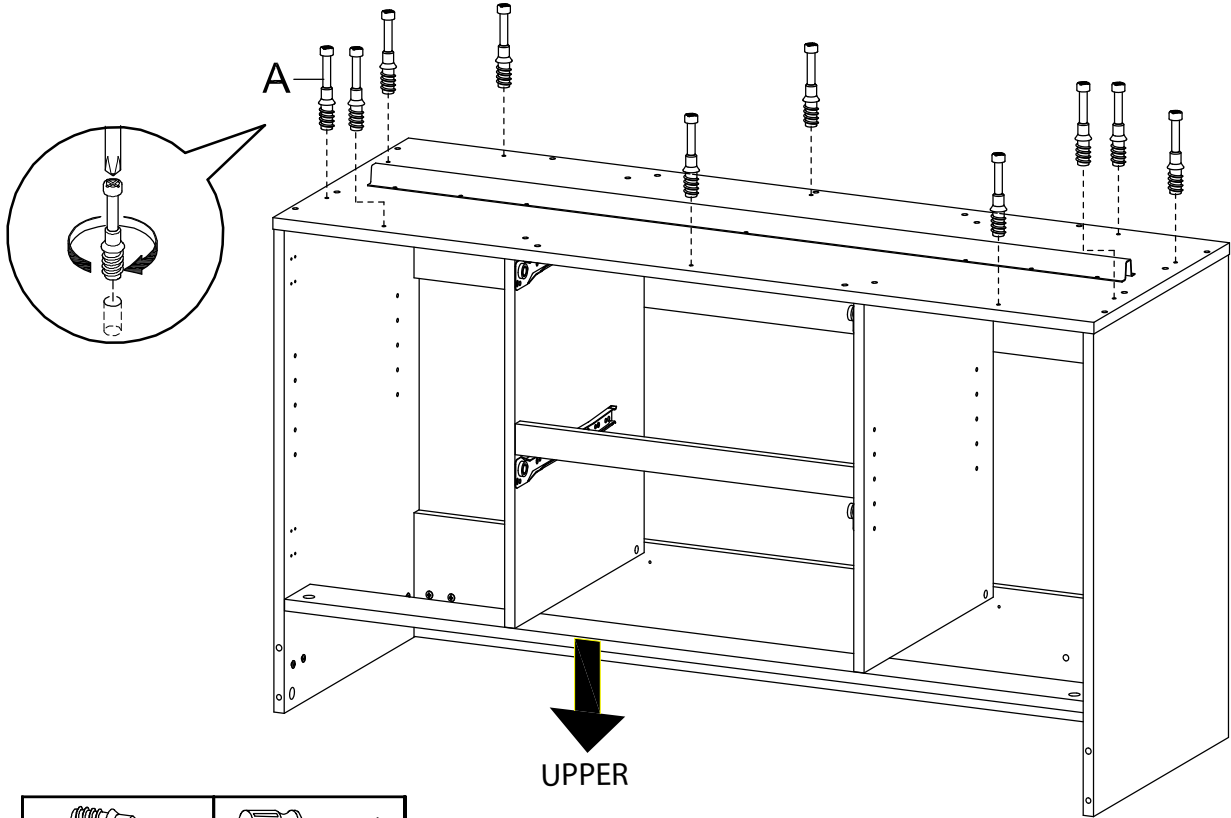
CABINET

STEP 21:

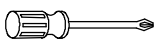

	
A x 10	W x 1

Hardware required.
Screwdriver not included

STEP 22:

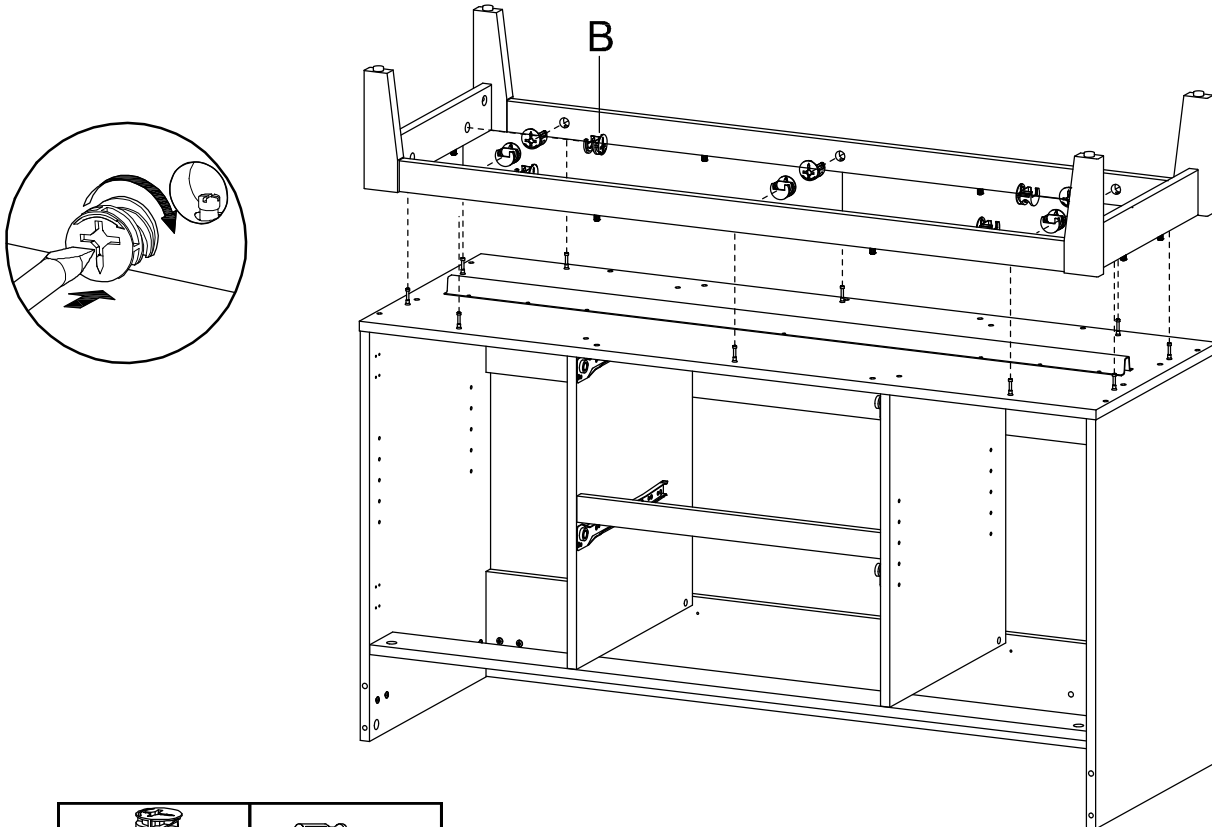

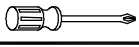



	
B x 10	W x 1

Hardware required.
Screwdriver not included

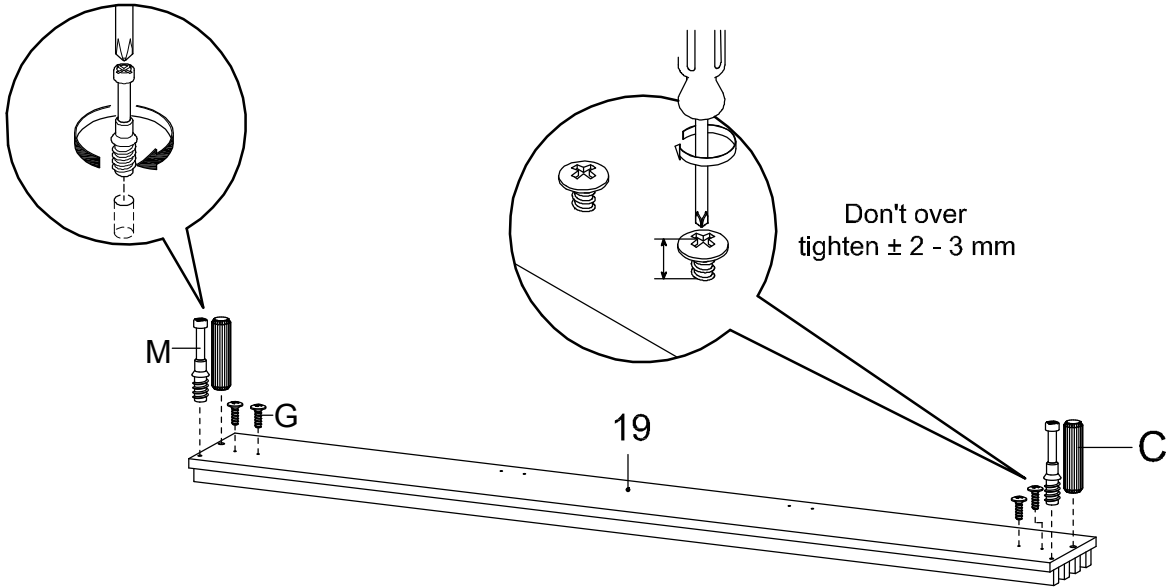
CABINET

STEP 23:



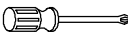

			
C x 2	M x 2	G x 4	W x 1

Hardware required.
Screwdriver not included

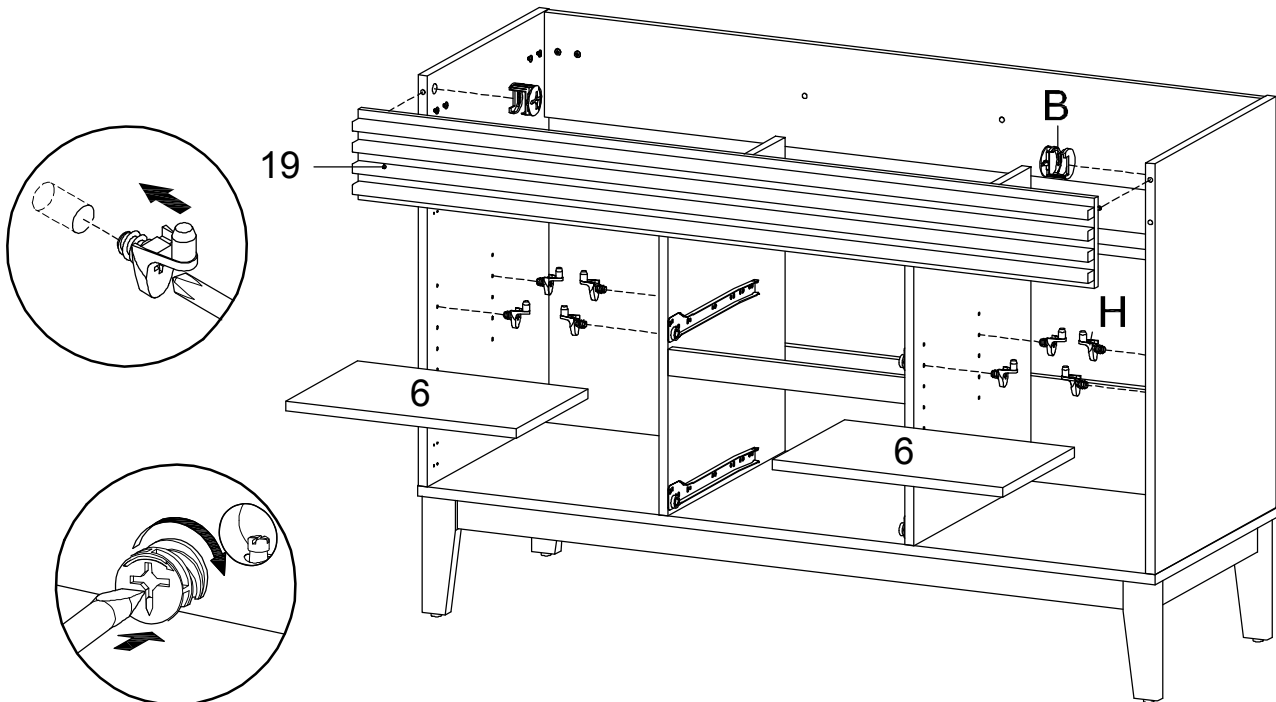
STEP 24



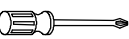



		
B x 2	H x 8	W x 1

Hardware required.
Screwdriver not included

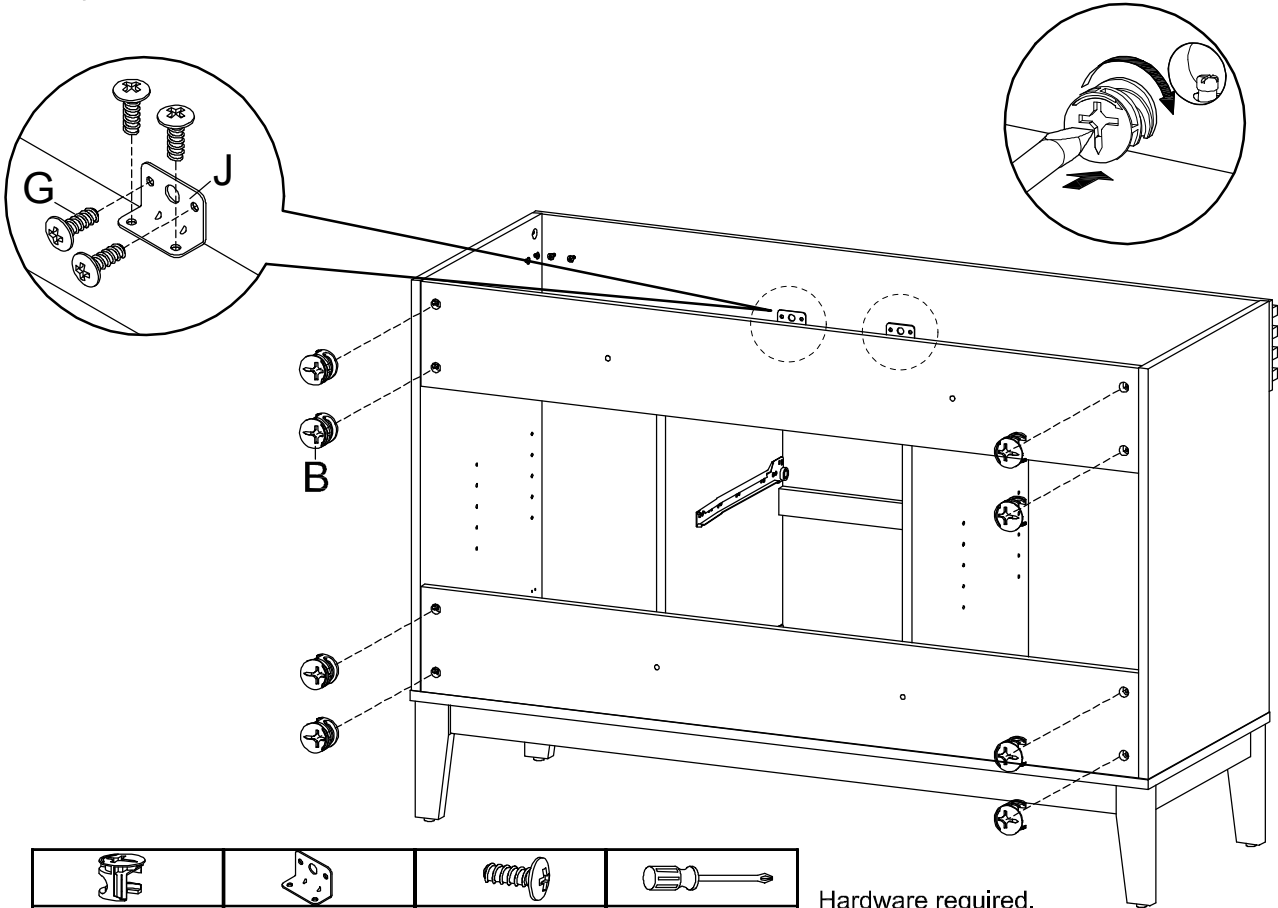
CABINET

STEP 25:





			
B x 8	J x 2	G x 8	W x 1

Hardware required.
Screwdriver not included

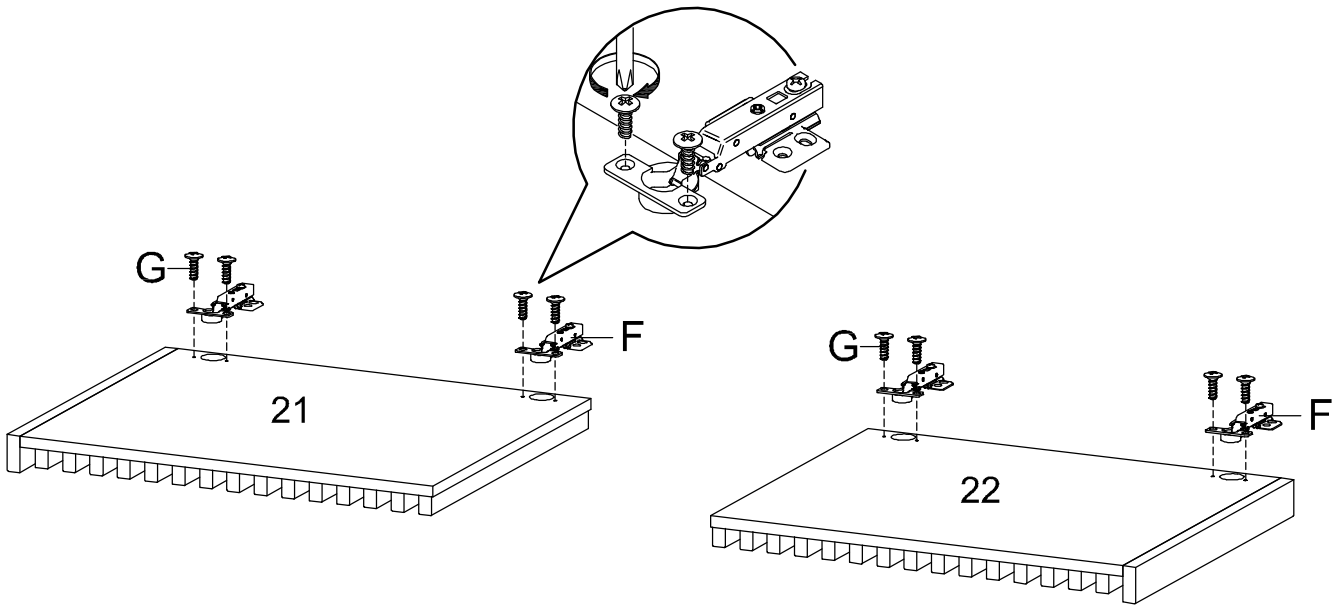
STEP 26



		
F x 4	G x 8	W x 1

Hardware required.
Screwdriver not included

CABINET

STEP 27

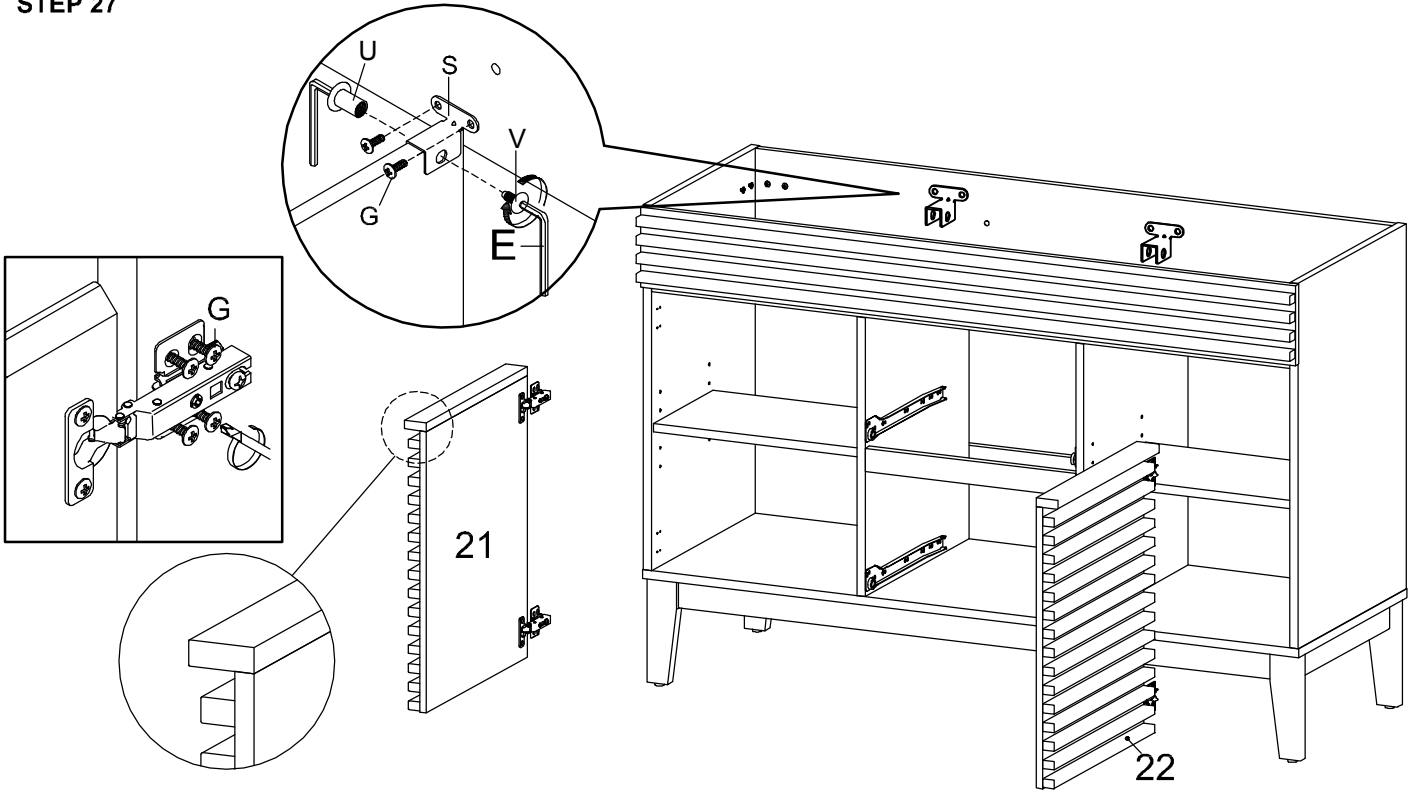

Hardware required.
Screwdriver not included

G x 20	E x 1	W x 2	U x 1	X x 2	W x 1

STEP 28

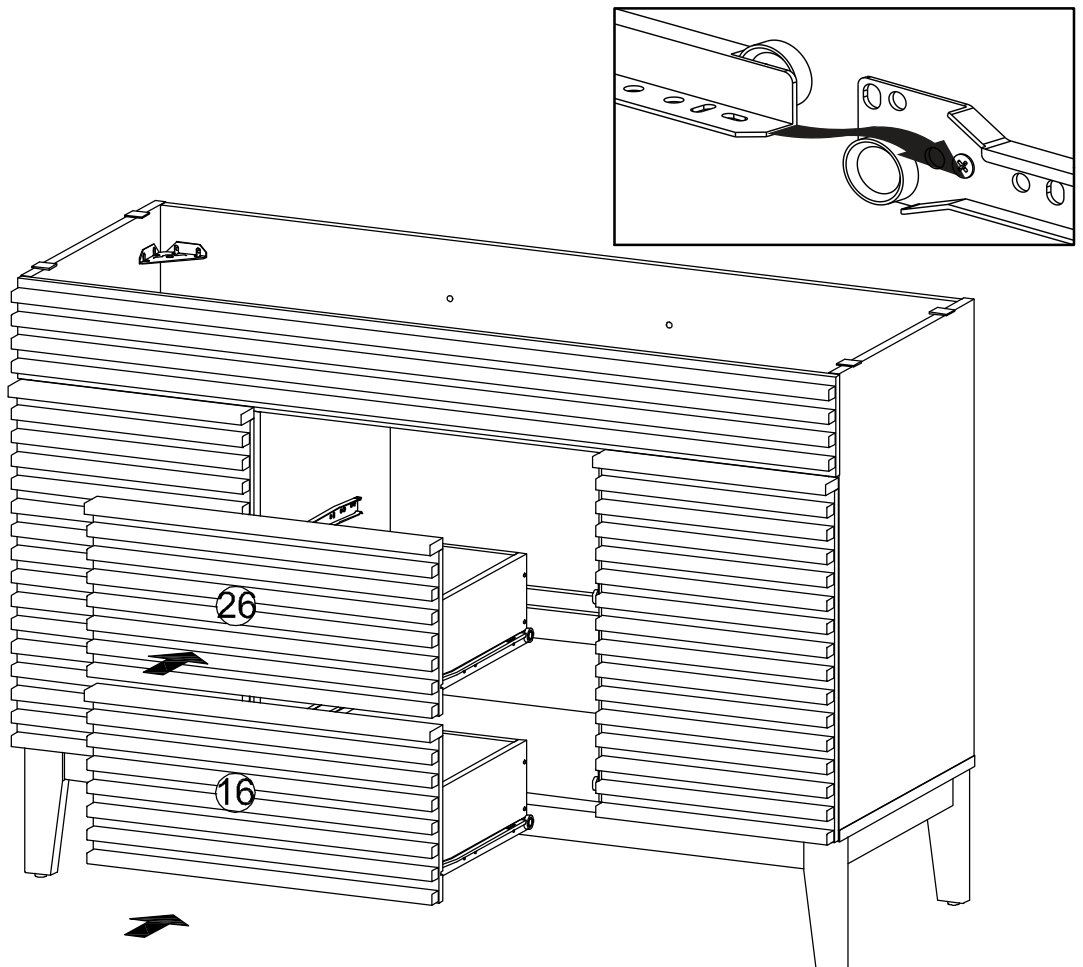

CABINET

STEP 29:

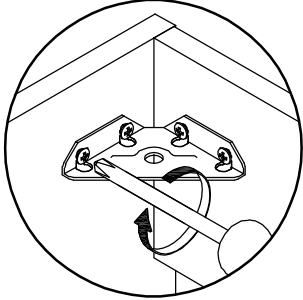
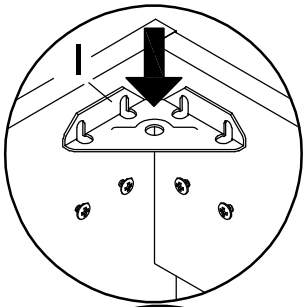

NOTE :
Tighten all the screw

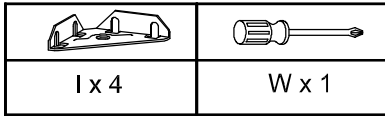
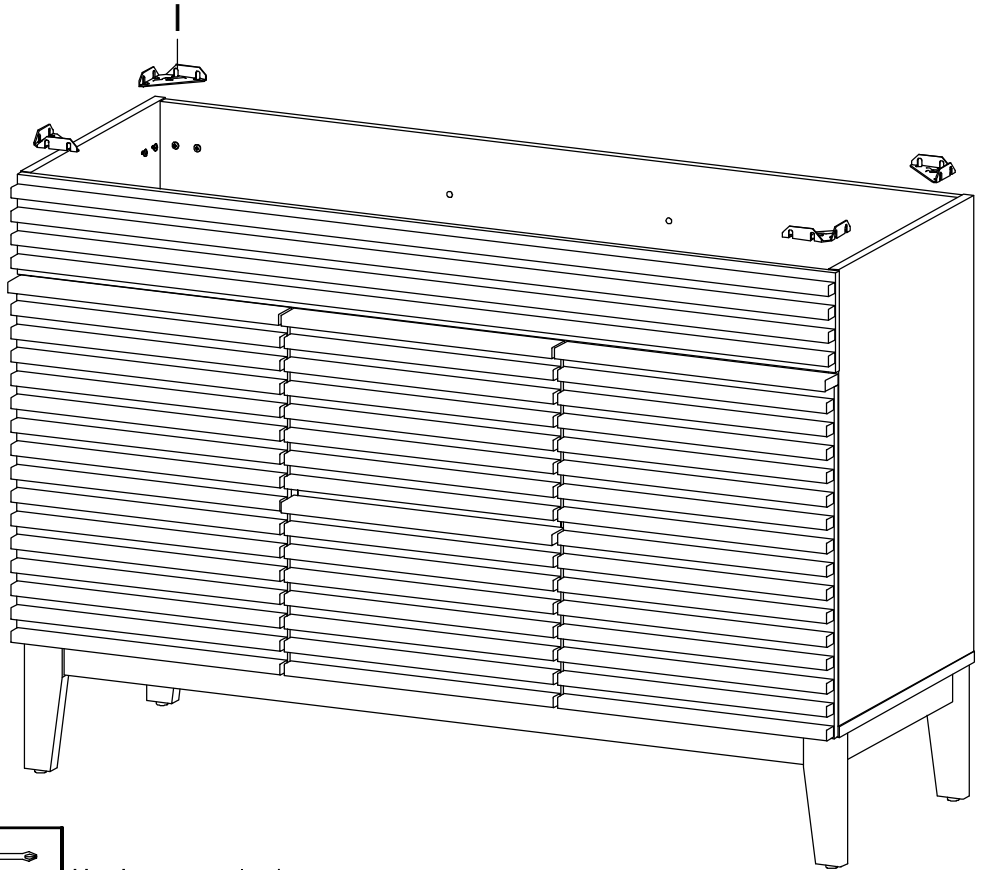

Hardware required.
Screwdriver not included

STEP 30:

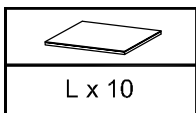
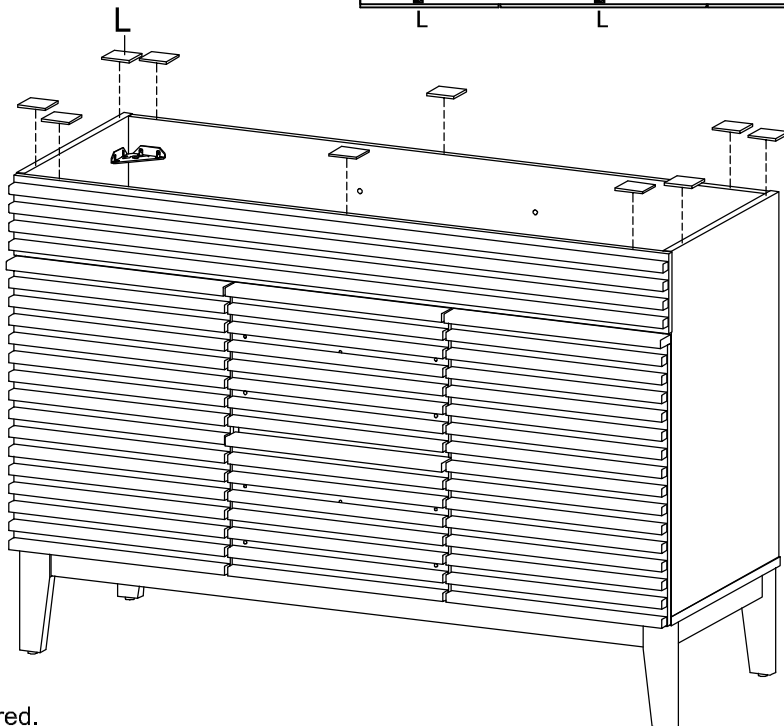
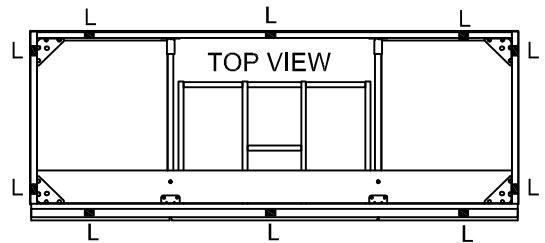
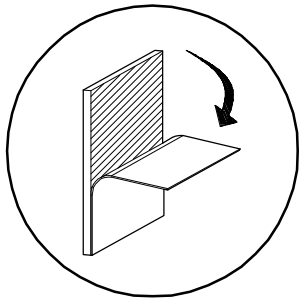

Hardware required.

CABINET

STEP 31 :

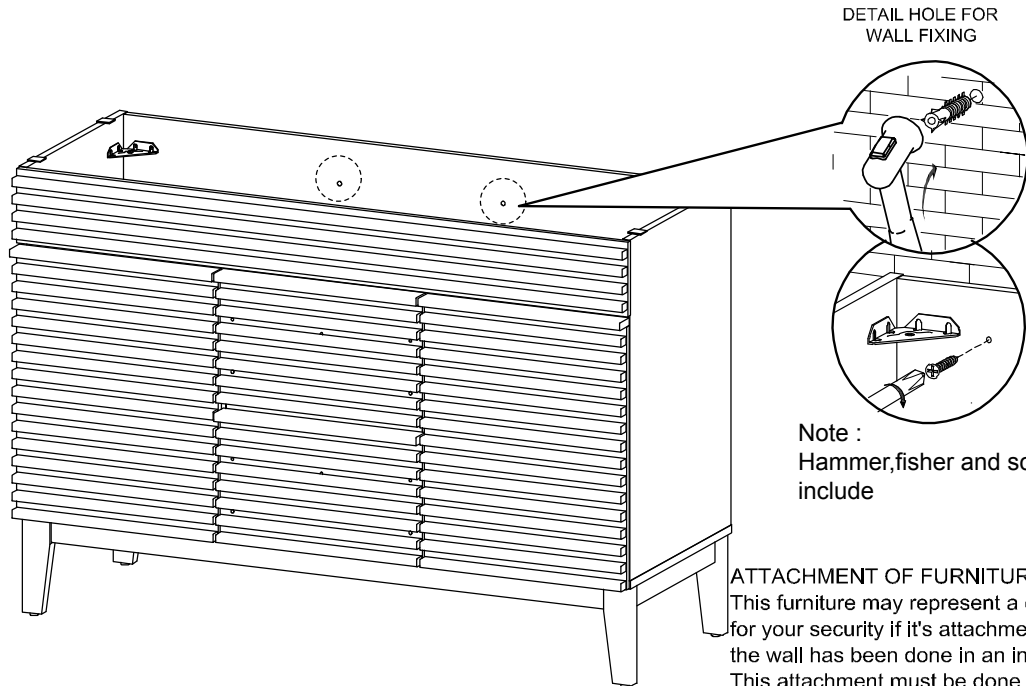

STEP 32:

Apply a thin bead of silicone compound around the vanity base and set the vanity top carefully in place. Remove any excess silicone compound with a wet rag

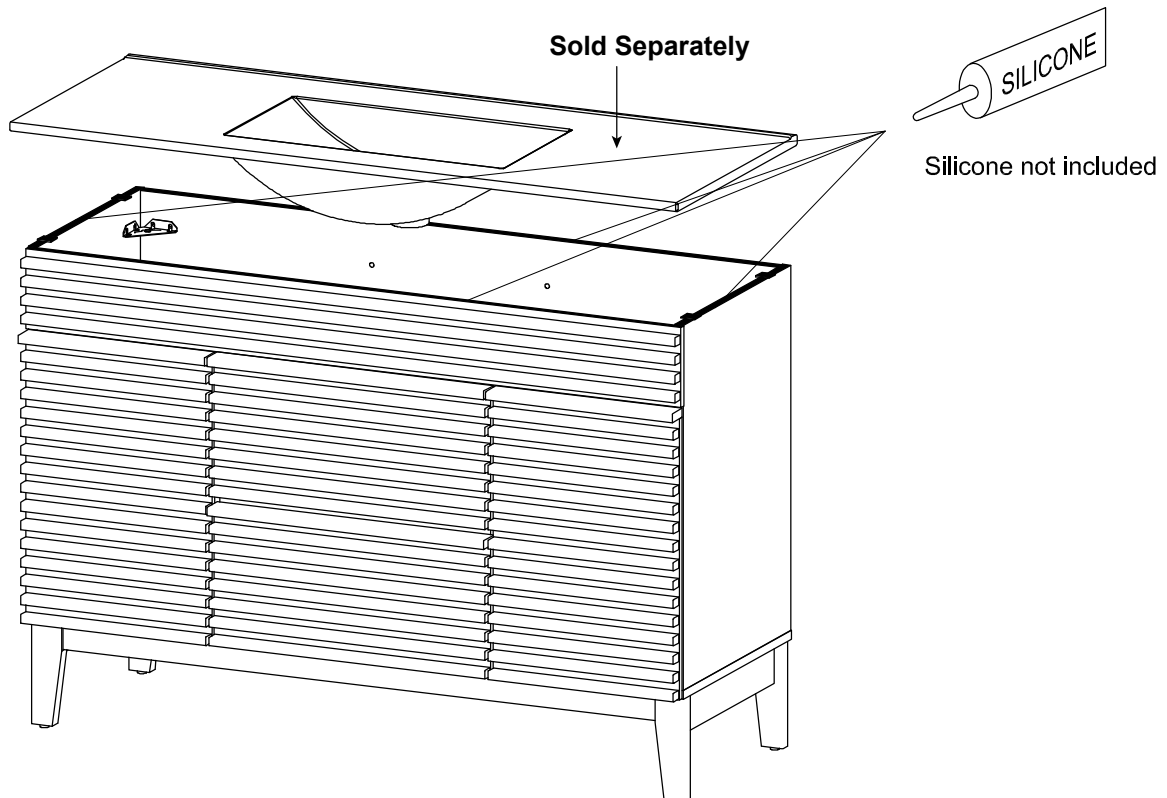

CABINET

STEP 33:

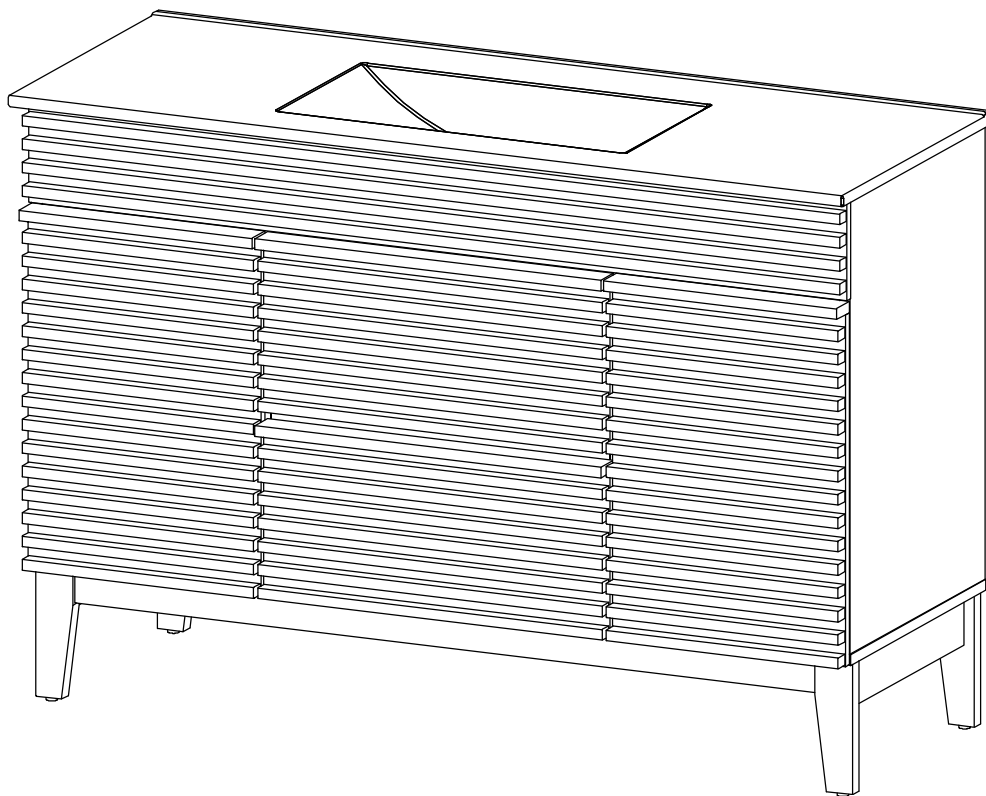

Assembly is complete. The Cabinet is ready to enjoy now !