

3645*3650*2150MM

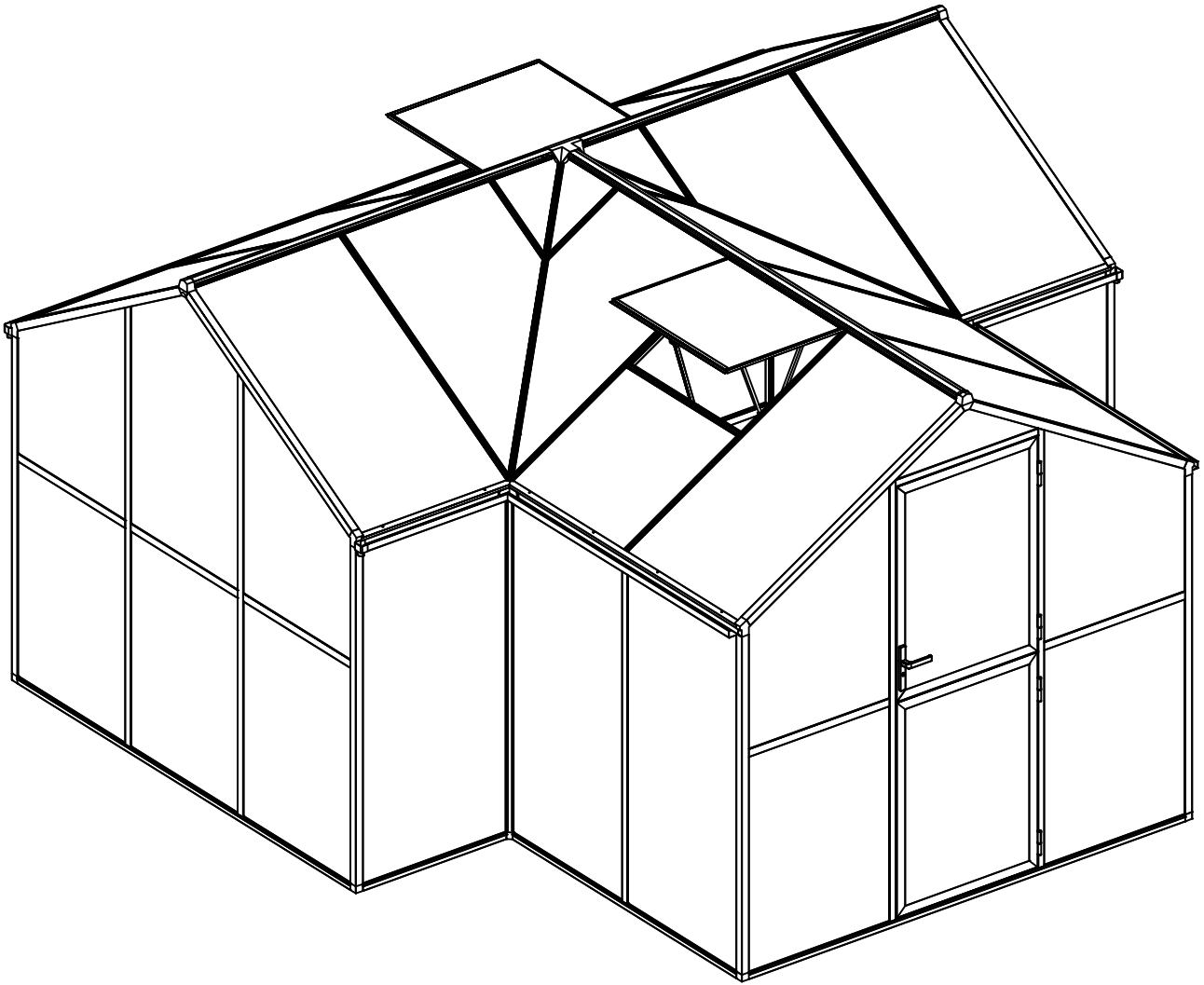

Please read all instructions carefully before assembly.
It is best to familiarize yourself with the parts and
collate the appropriate parts for each step.

If you encounter any problems during the assembly
process, contact us anytime !



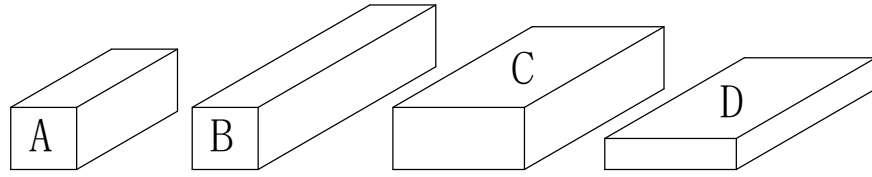





support@sylviera.com

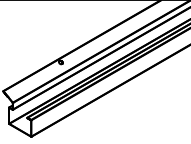
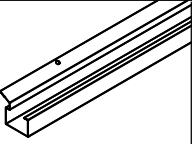
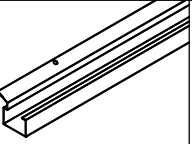
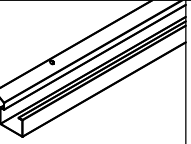
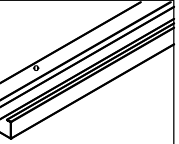
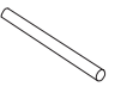
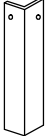

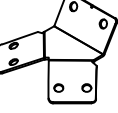
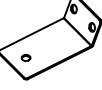
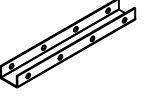



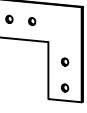

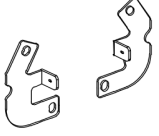

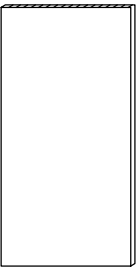
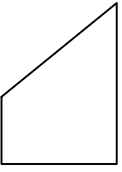
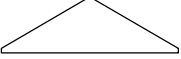
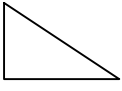





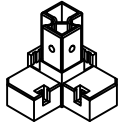

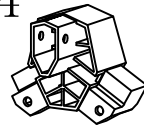

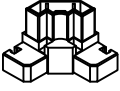
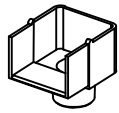
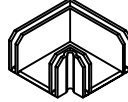
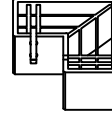
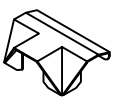
A1-1 X1	A1-2 X1	A2 X3	A3 X2	A4 X2	
A5-1 X1	A5-2 X1	A6-1 X1	A6-2 X1	A7-1 X1	
A7-2 X1	A8 X2	A8-1 X1	A9 X1	A10 X2	A11 X6
A12 X6	A13 X2	A14 X1	A15 X1	A16 X1	
A17-1 X2	A17-2 X2	A18 X6	A19 X2	A20-1 X2	
A20-2 X2	A21-1 X2	A21-2 X2	A22 X2	A23 X1	
A24 X1	A25 X1	A26 X1	A27 X2	A28 X1	
A29 X2	A30 X2	A31 X8	A32 X6	A33 X4	A34 X8

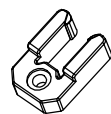

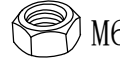

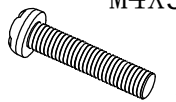
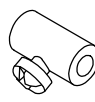

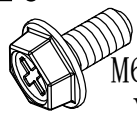
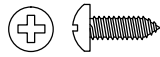
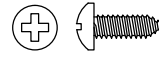
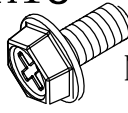
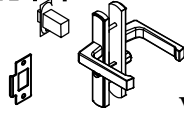
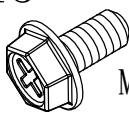
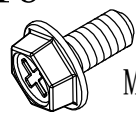
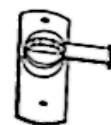
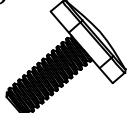
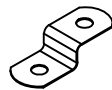

Z1 X1	Z2 X1	Z3 X1	Z4 X1	Z5 X2
Z6 X2	Z7 X6	Z8 X2	Z9 X1	Z10 X2
Z11 X1	Z12 X13	Z13 X2	Z14 X4	Z15 X2
Z16 X4	Z17 X3	Z18 X3	Note: Before assembly, it is necessary to remove the film on both sides of the PC board ;	

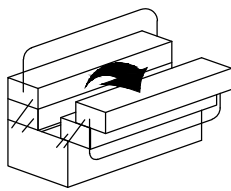
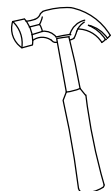
	B1	9PCS
	B2	2PCS
	B5	8PCS
	B8	11PCS
	B10	2PCS
	B3-L	2PCS
	B3-R	2PCS
	B6-L	3PCS
	B6-R	3PCS
	B7	1PC
	B4-L	3PCS
	B4-R	3PCS
	B9	2PCS
	B11	2PCS

Z1  X1	Z2  X1	Z3  X1	Z4  X1	Z5  X2
Z6  X2	Z7  X6	Z8  X2	Z9  X1	Z10  X2
Z11  X1	Z12  X13	Z13  X2	Z14  X4	Z15  X2
Z16  X4	Z17  X3	Z18  X3	Note: Before assembly, it is necessary to remove the film on both sides of the PC board ;	

	B1	9PCS
	B2	2PCS
	B5	8PCS
	B8	11PCS
	B10	2PCS
	B3-L	2PCS
	B3-R	2PCS
	B6-L	3PCS
	B6-R	3PCS
	B7	1PC
	B4-L	2PCS
	B4-R	2PCS
	B9	2PCS
	B11	2PCS

	T1  X6	T2  X3	T3  X3	T4  X3
T5  X2	T6  X2	T7  X6	T8  X2	T9  X8
T10  X1	H1  X1	H2  X2	H3  X1	H4  M6 X23
H5  X1	H6  M4X38 X2	H7  X4	H8  M4X13 X46	H9  X6
H10  M6x12 X151	H11  4x10 X6	H12  5x10 X58	H13  M6x25 X4	H14  X1
H15  M6x35 X14	H16  M6x40 X4	H17  X1	H18  X2	H19  X12
H20  X4	H22  5X15 X2			

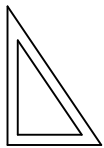
						 M6	
							

Please read the following carefully before assembling

Precautions for assembling the PC board :

1. Before assembly, it is necessary to remove the film on both sides of the PC board ;
2. It is recommended that glass glue can be applied to the edges of the PC board when installing it to enhance the overall firmness.

Warning: Do not install in windy weather!





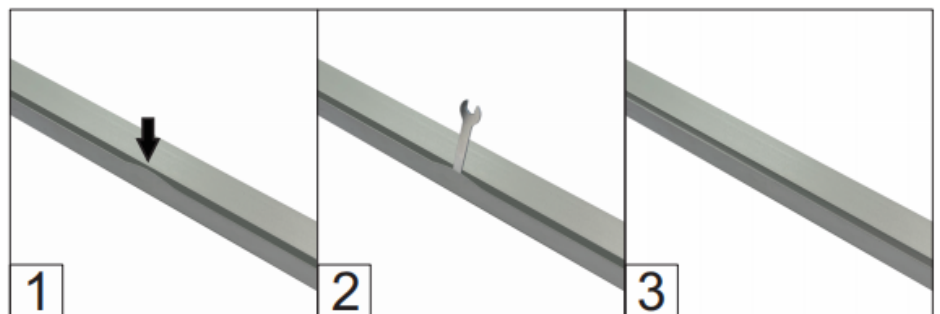

Warning:

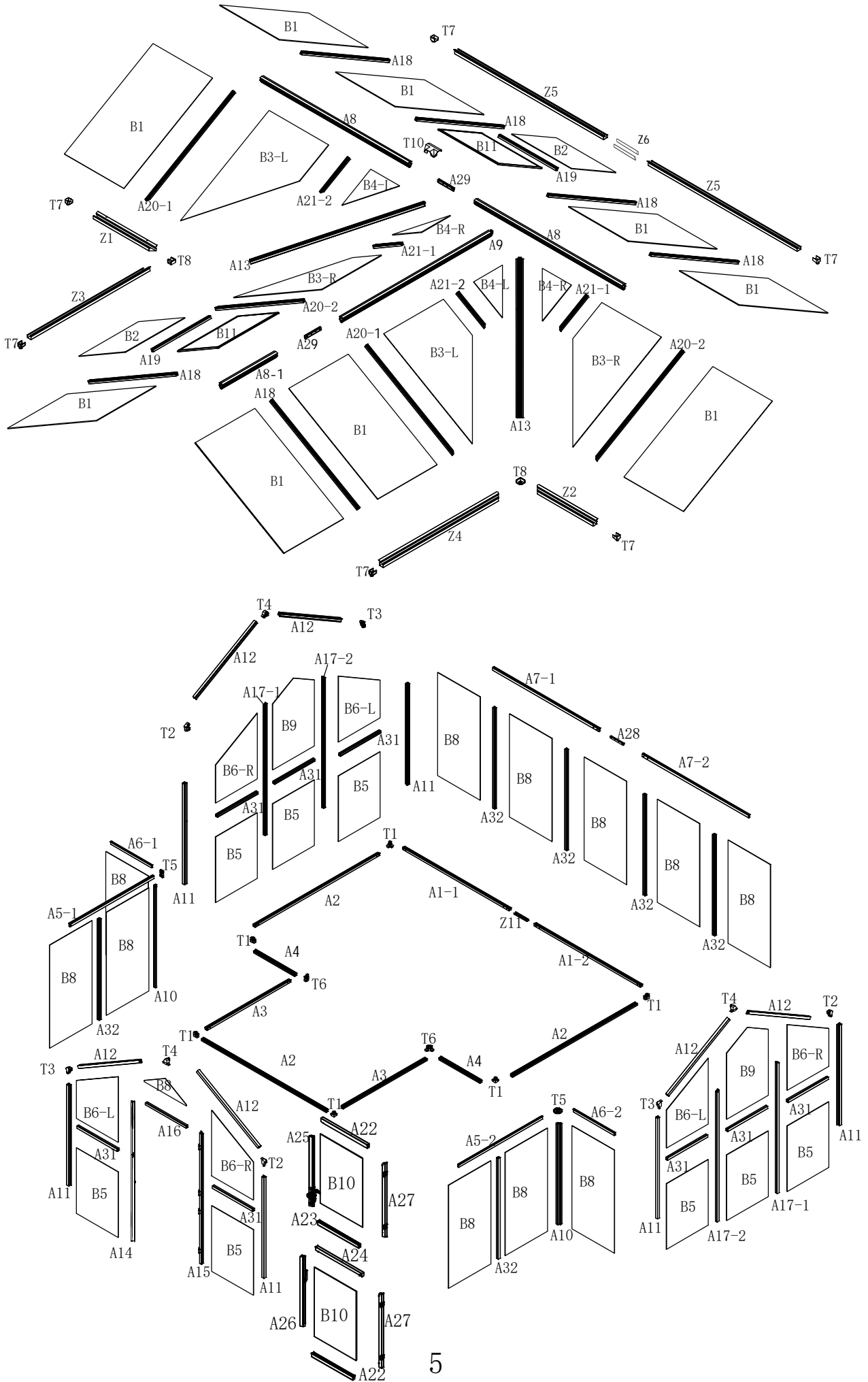
If the aluminum part curved as below pic, pls use the wrench to restore it.





Warning: Do not install in windy weather!

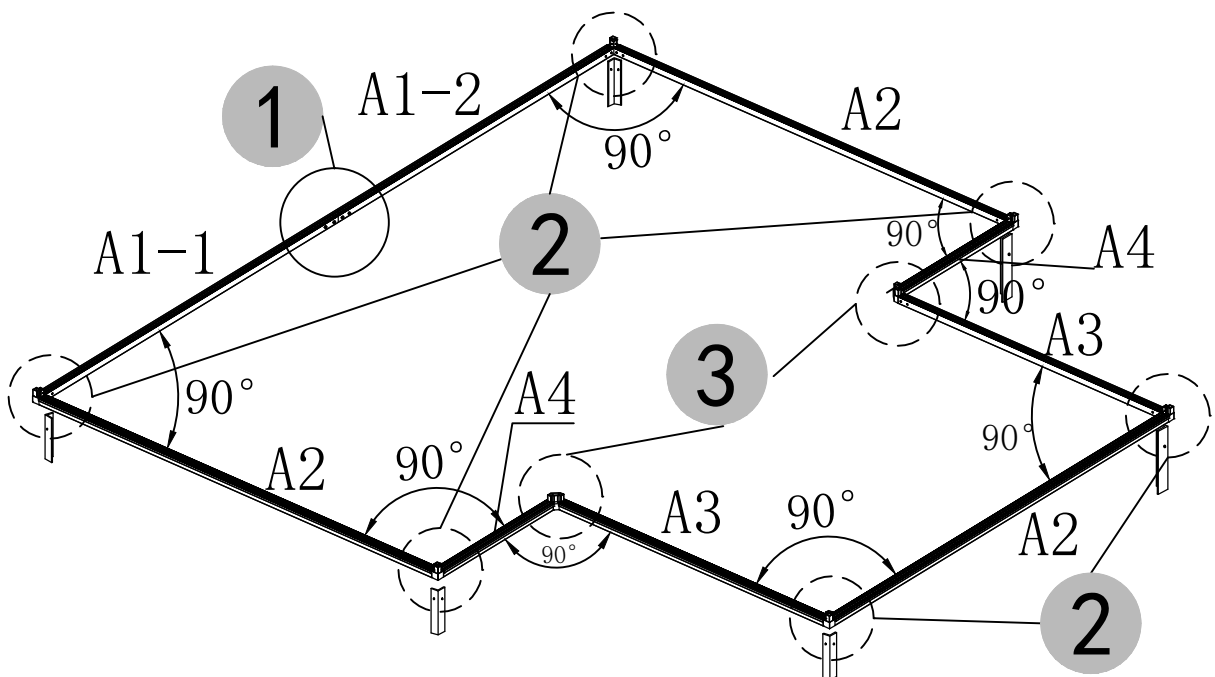
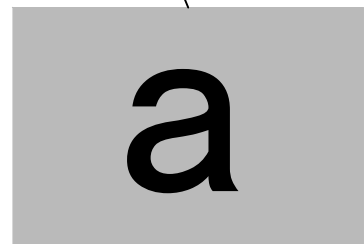
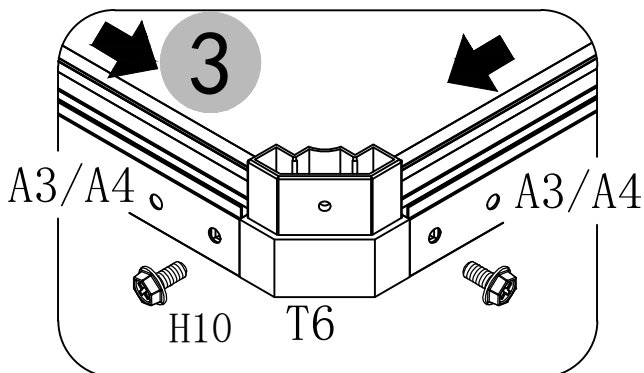
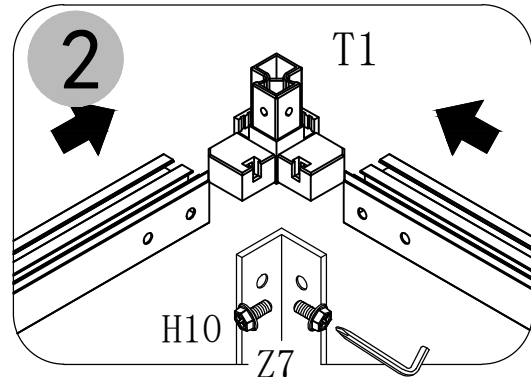
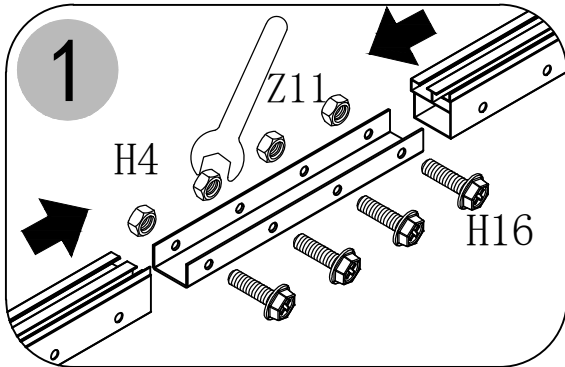

	T1	6pcs		H10	16pcs
	T6	2pcs		H16	4pcs
	Z11	1pc		H4	4pcs
	Z7	6pcs			



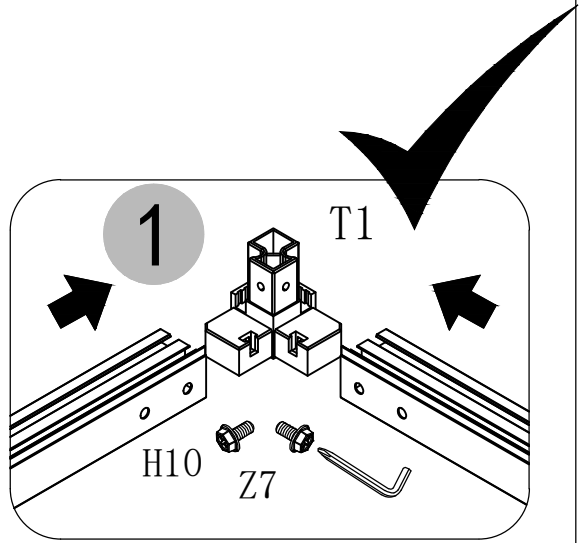
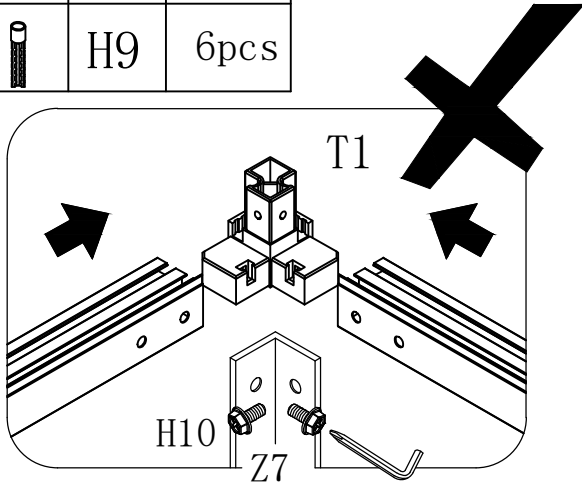

	Z7	6pcs
	H8	12pcs
	H9	6pcs

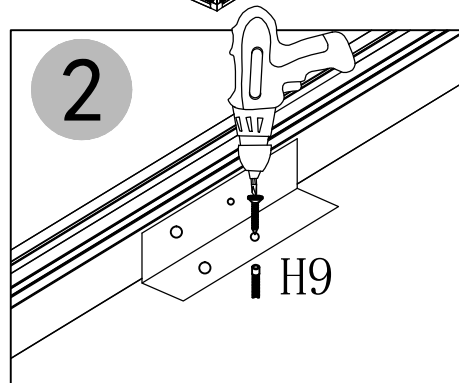
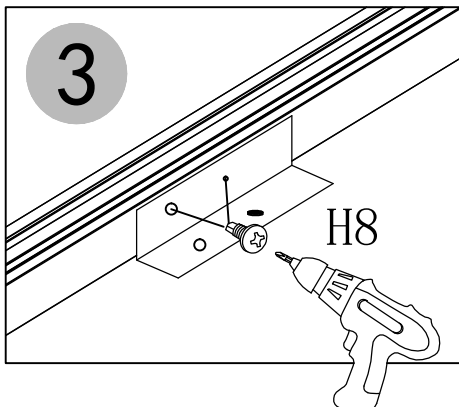
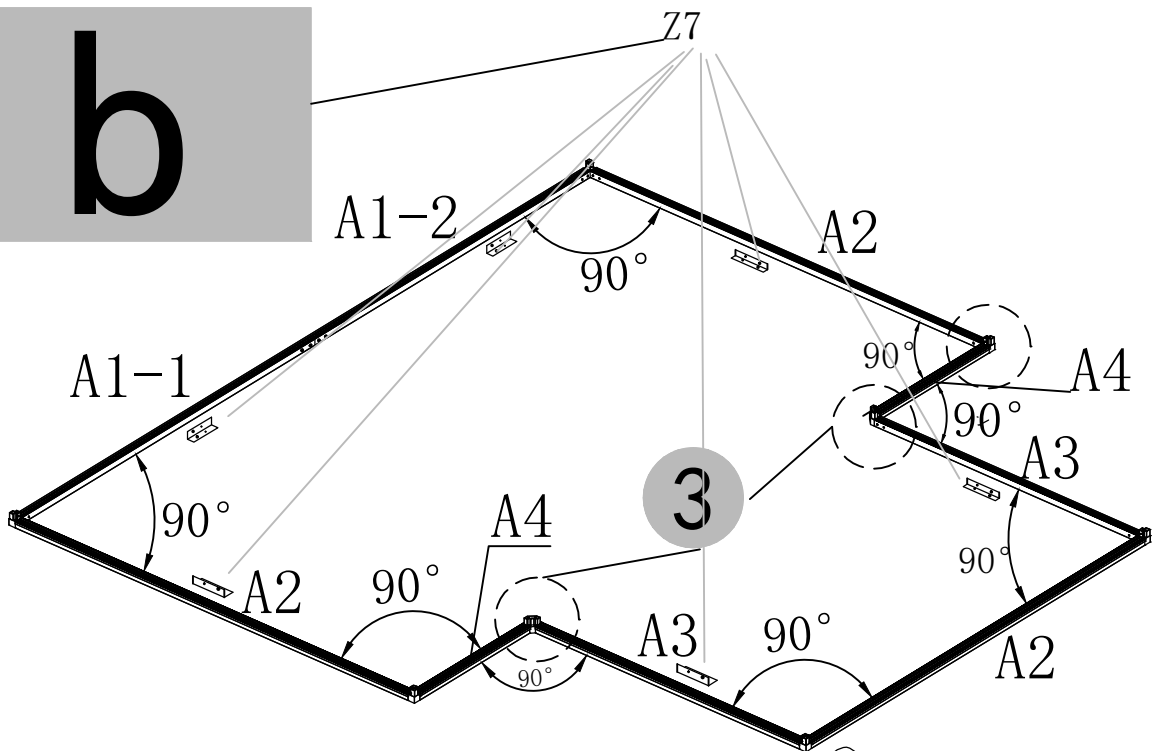

b





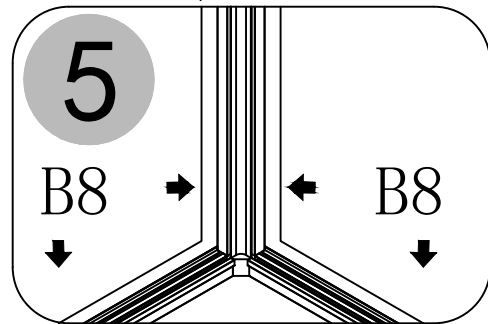
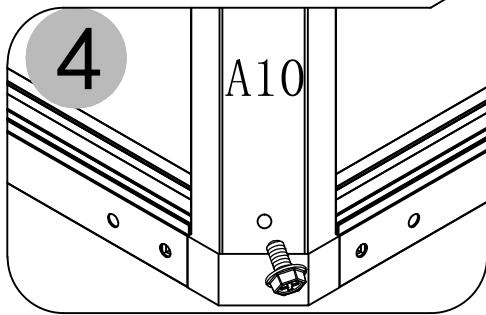
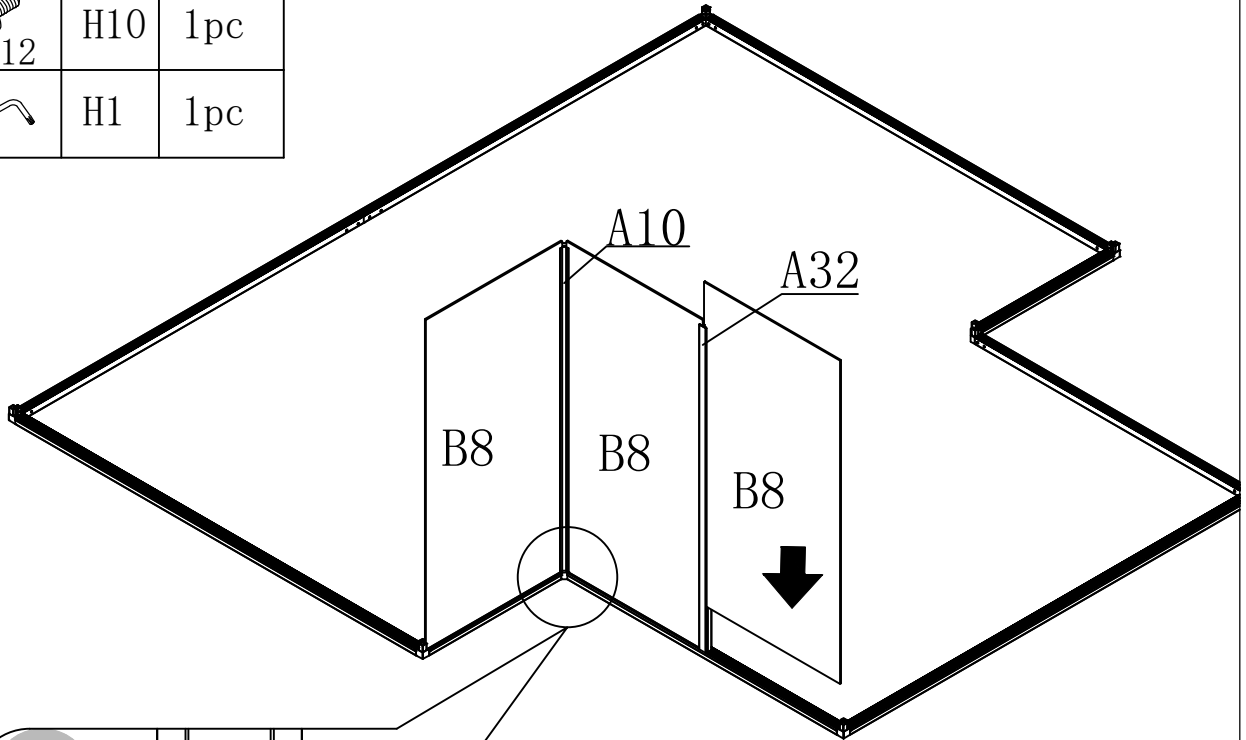

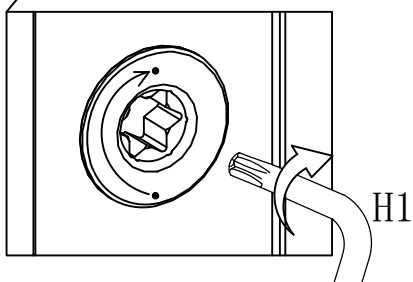
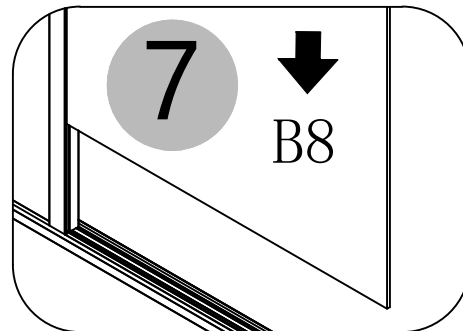
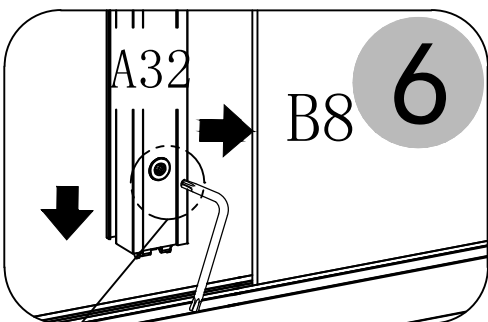

	H10	1pc
	H1	1pc





ATTENTION: The Orientation
Single hole facing downwards



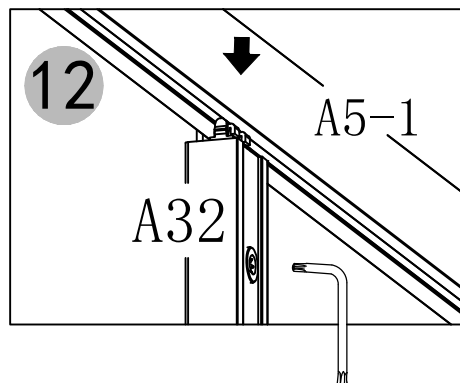
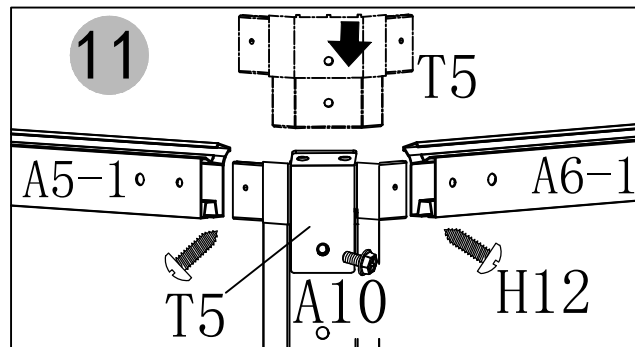
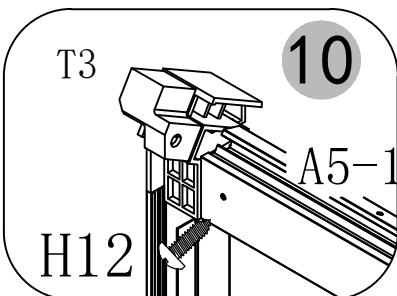
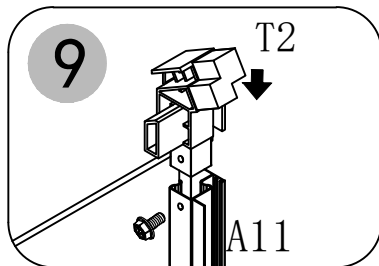
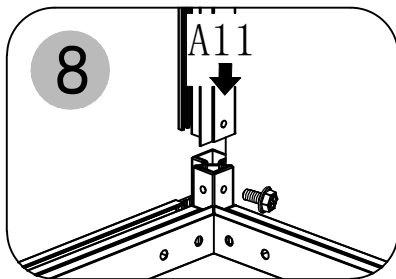
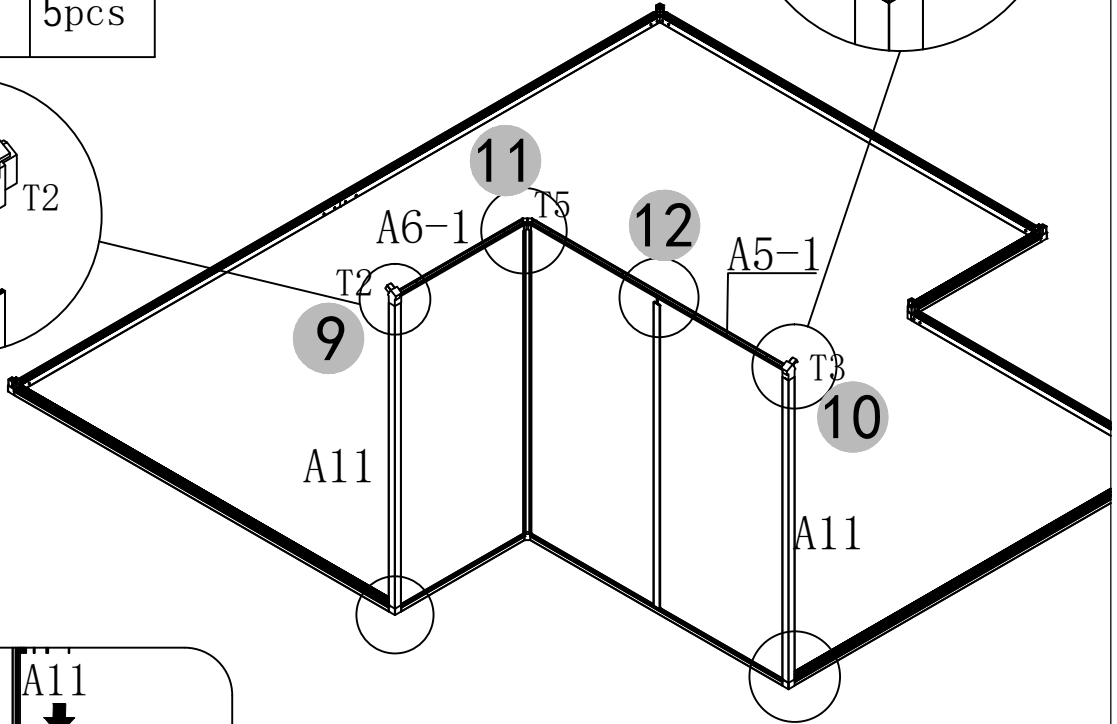
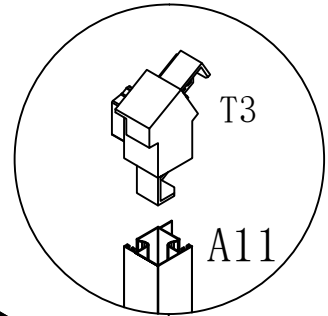
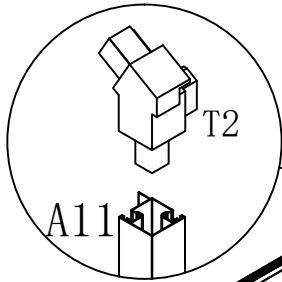

	T2	1pc		H12	4pcs
	T3	1pc		Z10	1pc
	T5	1pc			
	M6x12	5pcs			



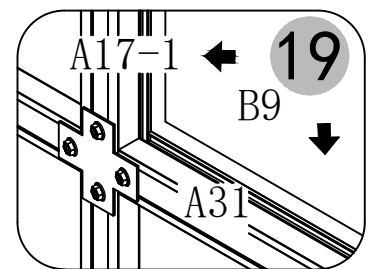
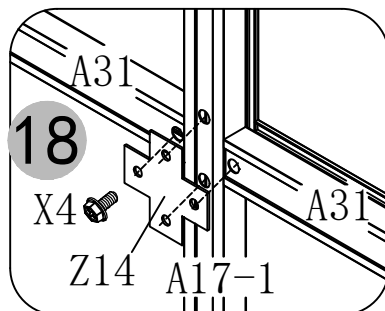
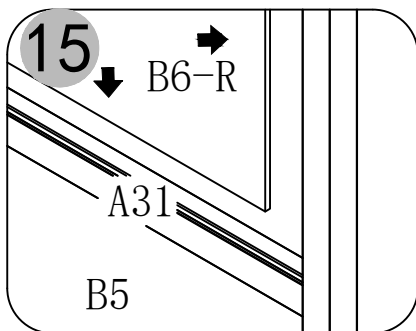
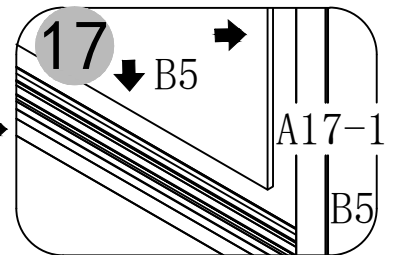
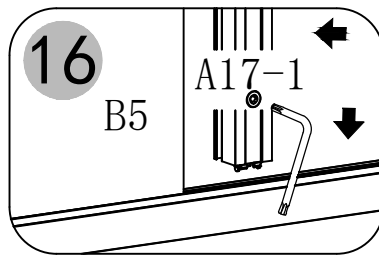
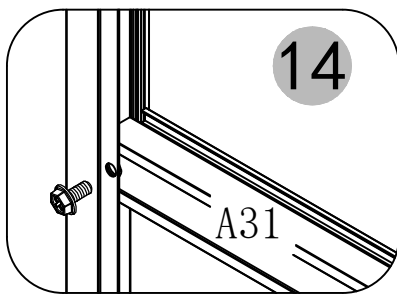
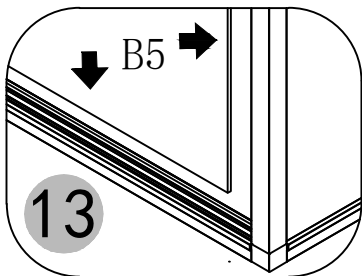
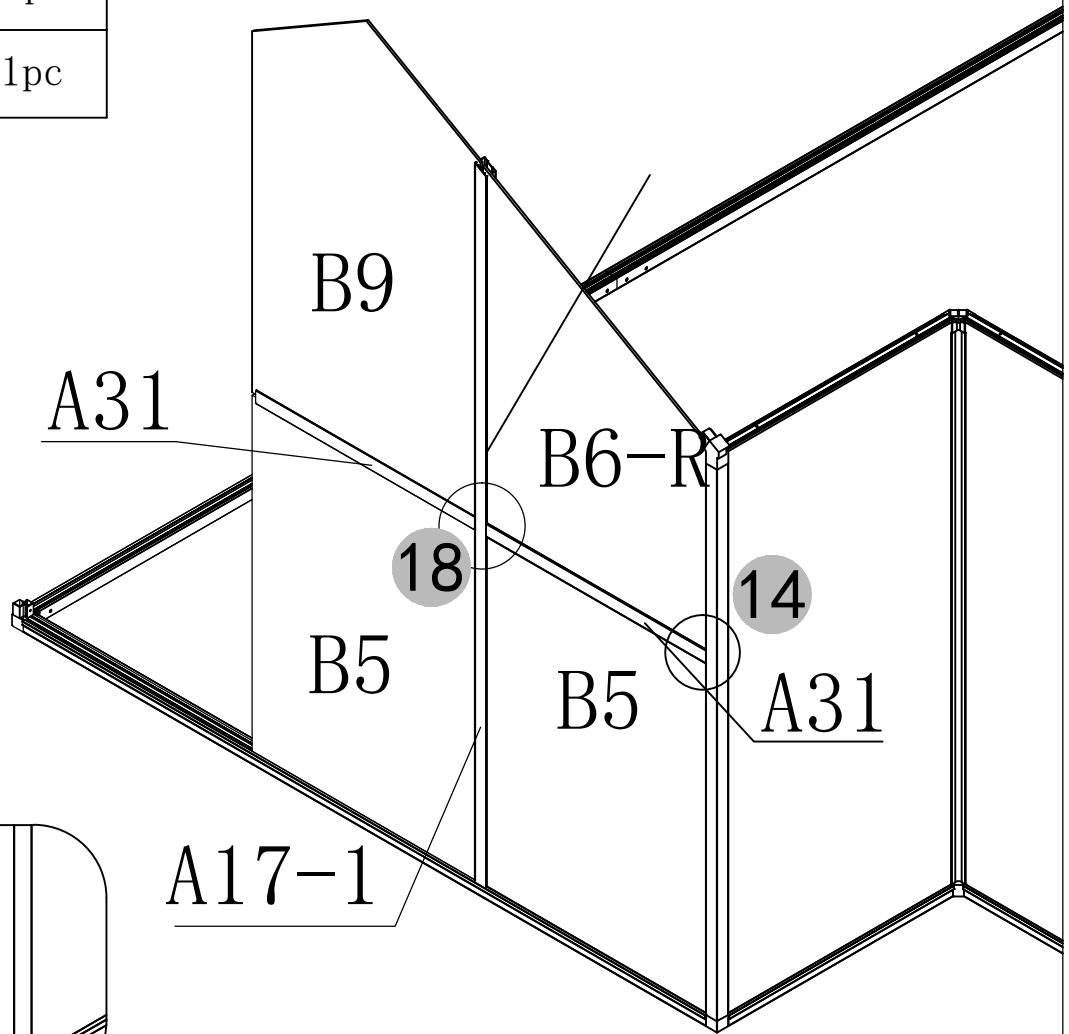

	H10	5pcs
	Z14	1pc

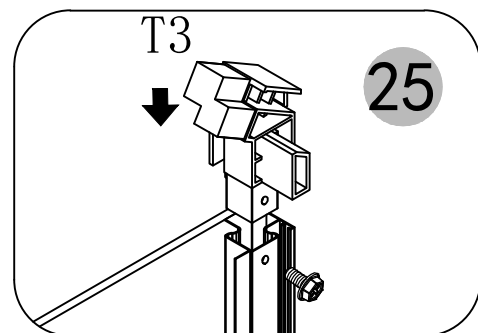
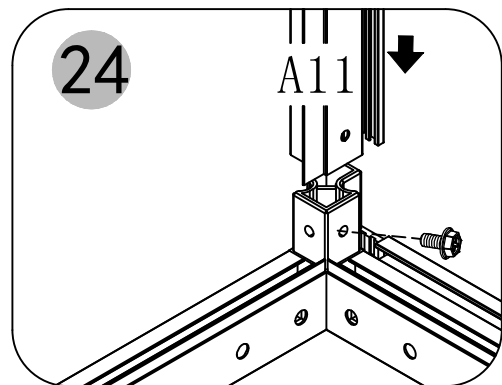
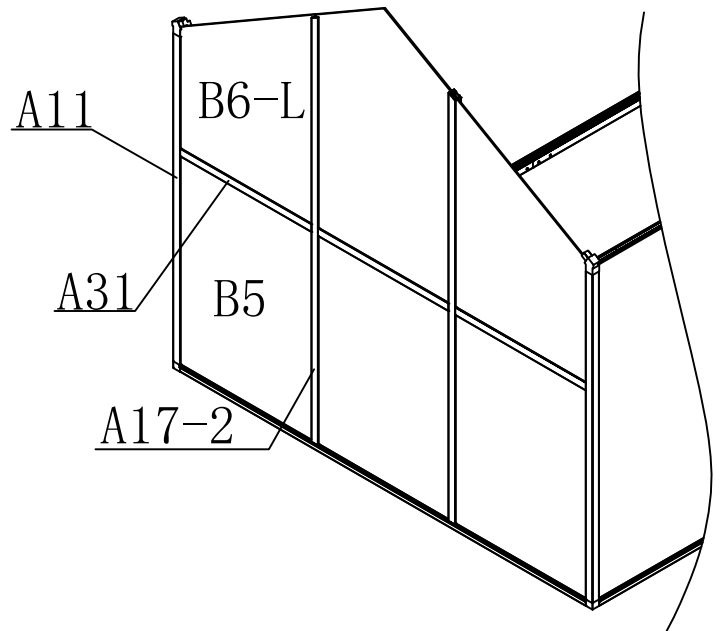
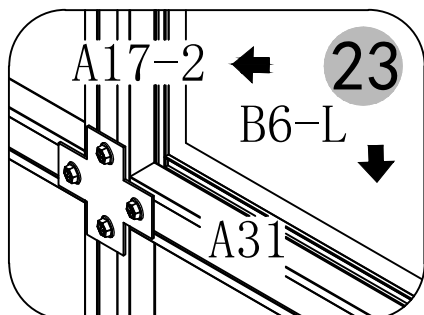
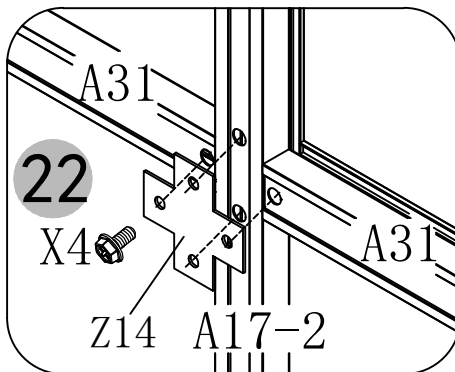
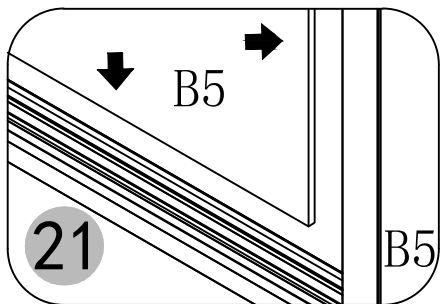
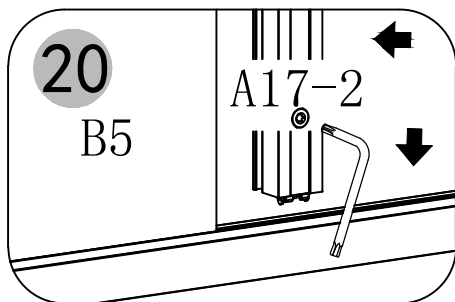

	H10	5pcs
	Z14	1pc
	T3	1pc



	H10	4pcs
	Z15	1pc

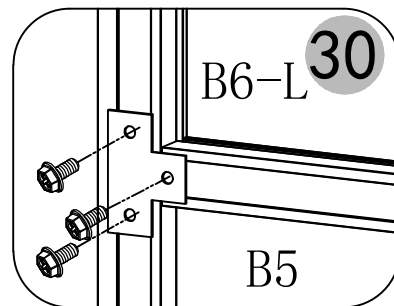
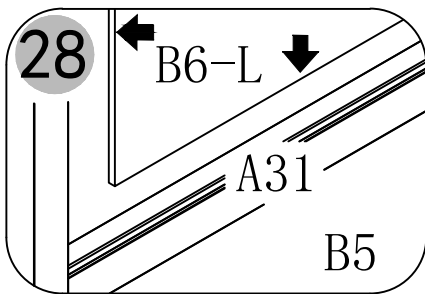
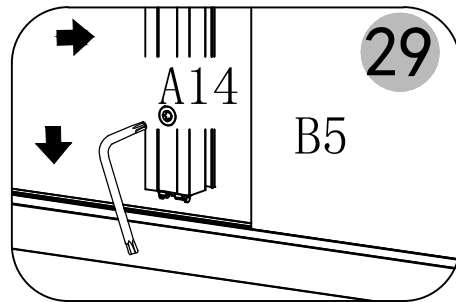
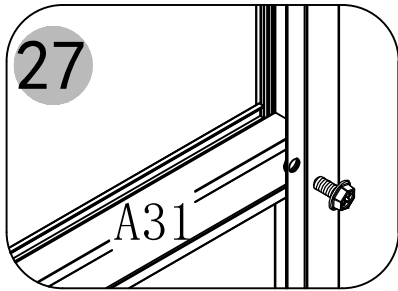
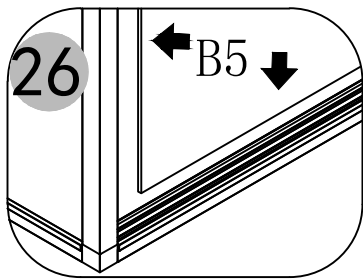
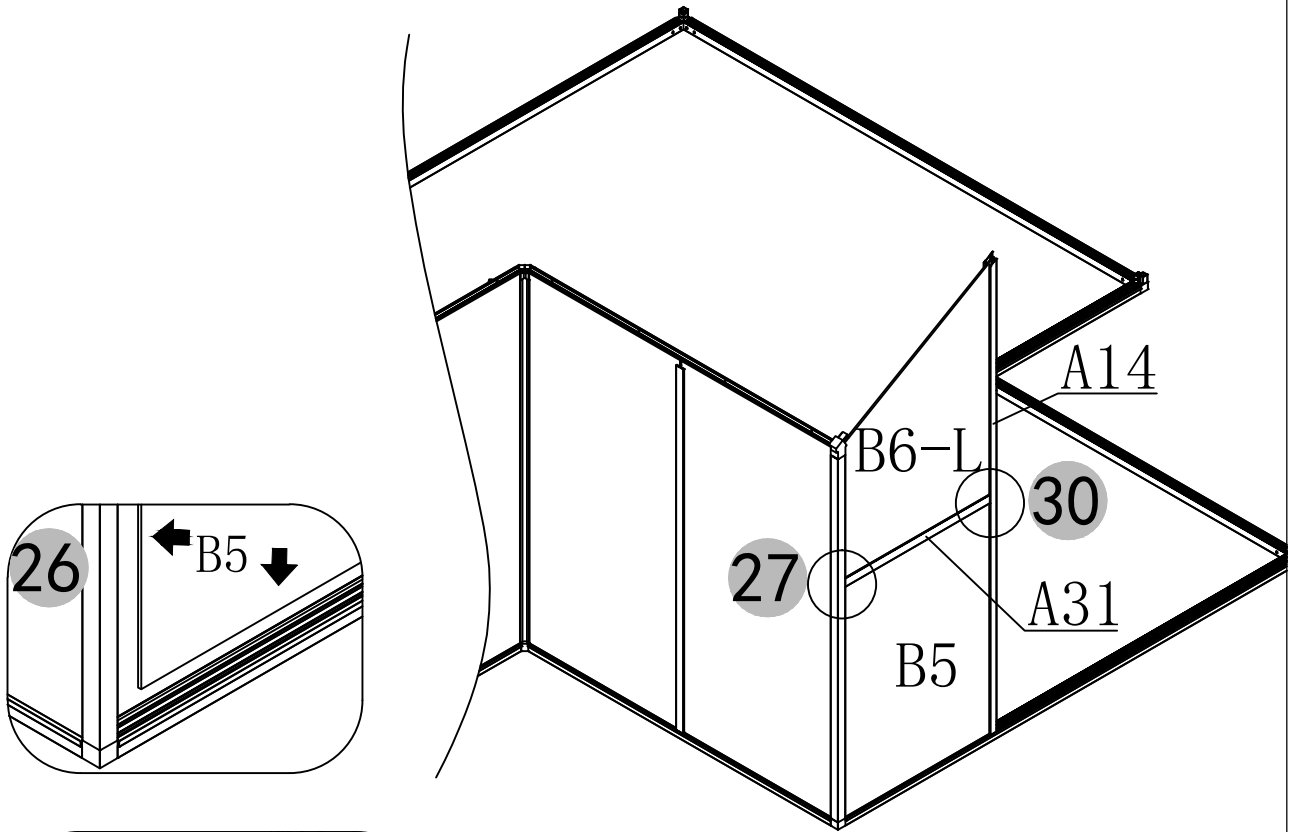



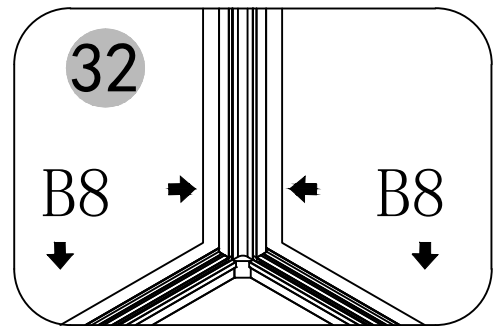
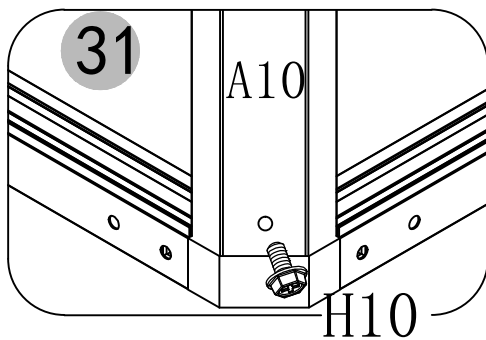
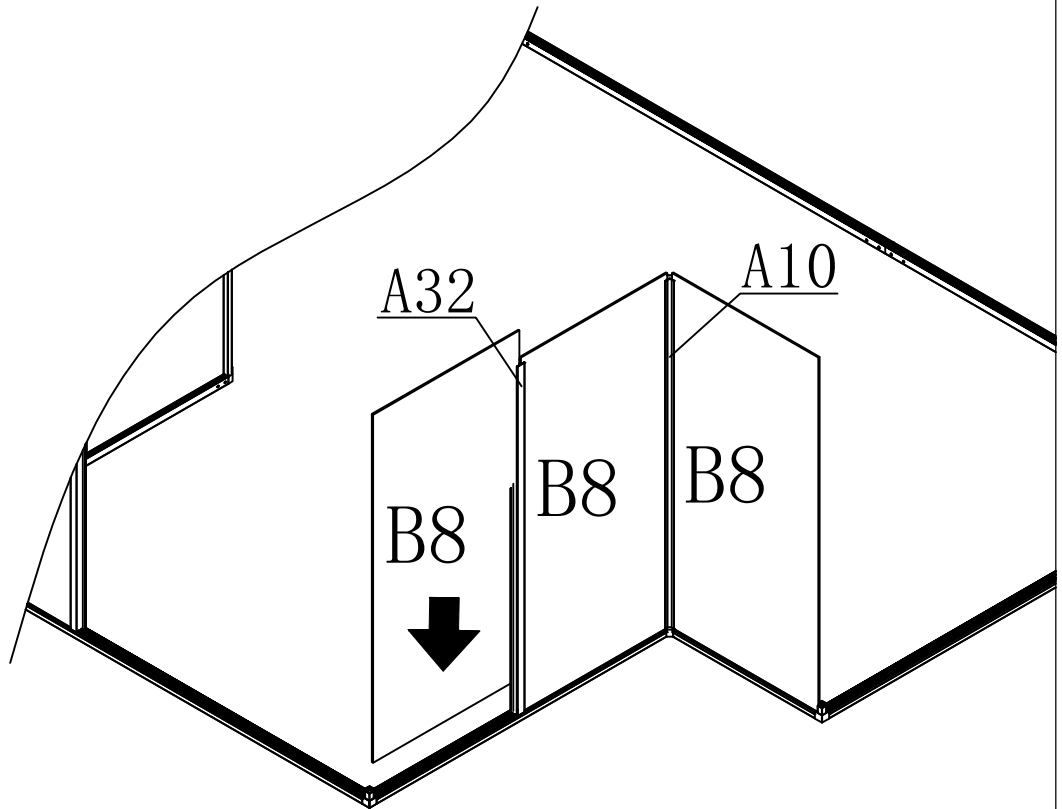

	H10	1pc
---	-----	-----

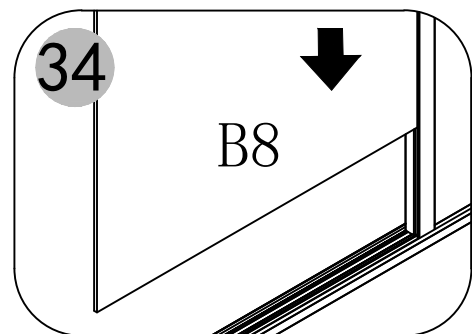
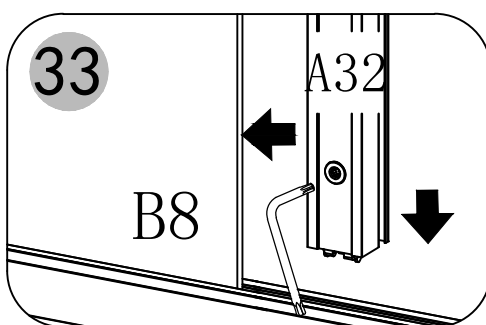

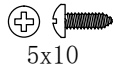

 ATTENTION: The Orientation
Single hole facing downwards

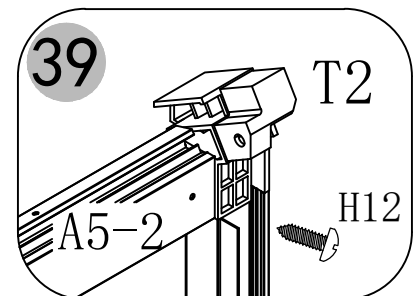
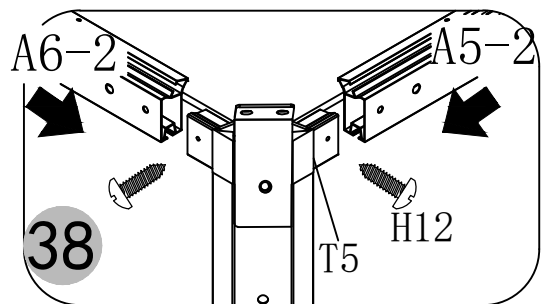
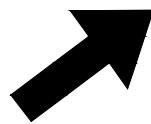
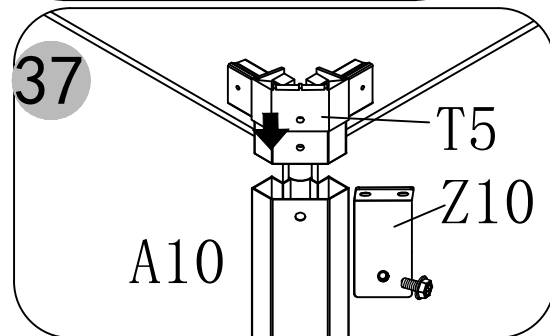
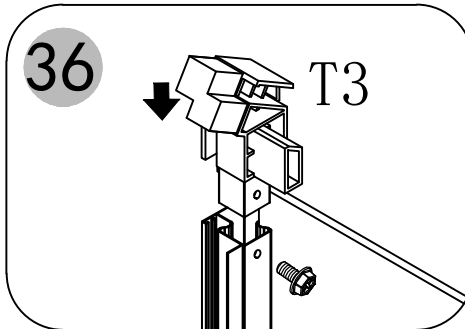
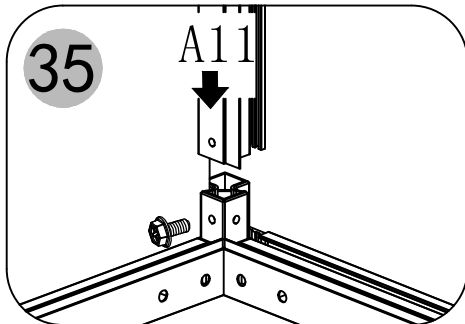
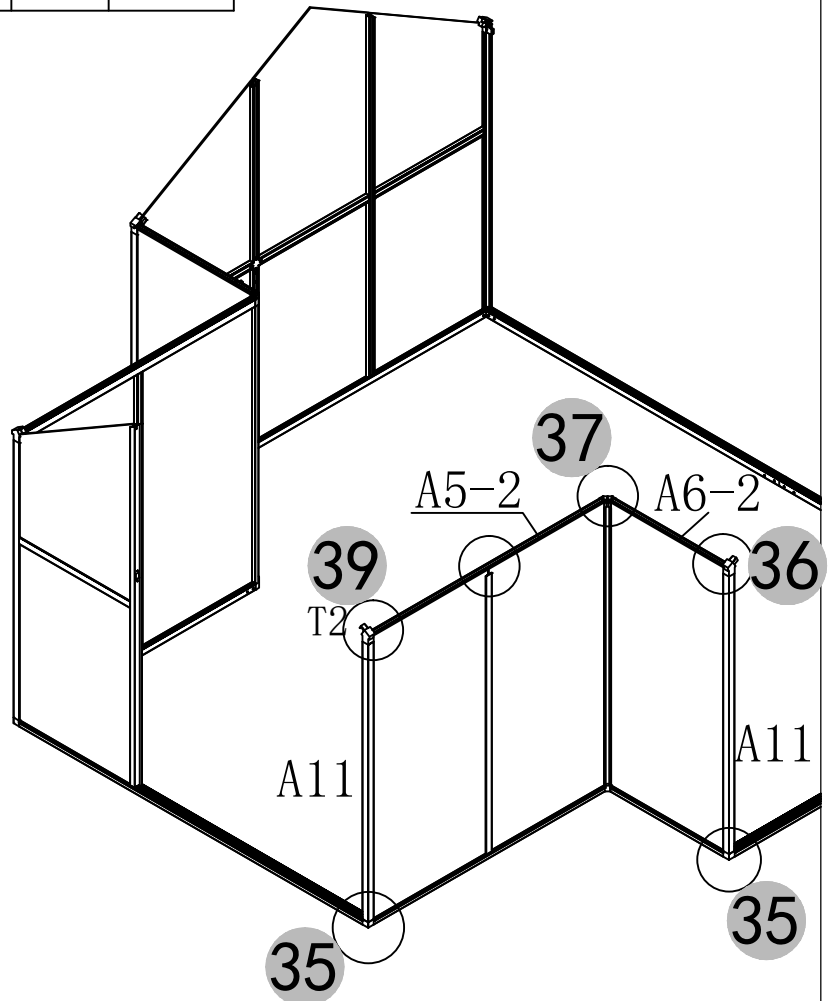

	T2	1pc		H12	4pcs
	T3	1pc		Z10	1pc
	T5	1pc			
	M6x12	5pcs			



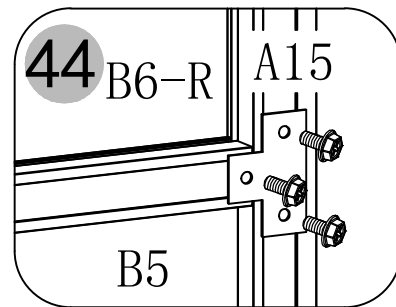
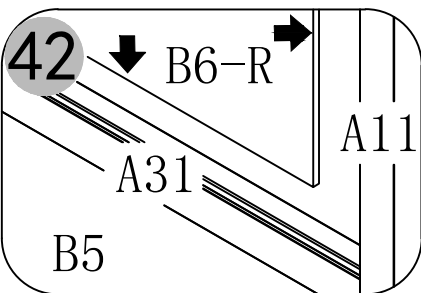
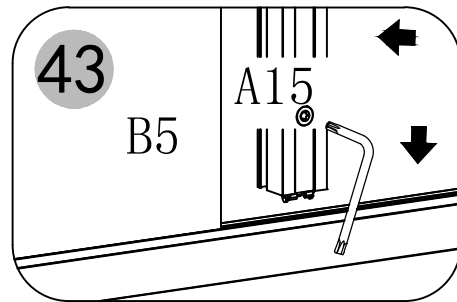
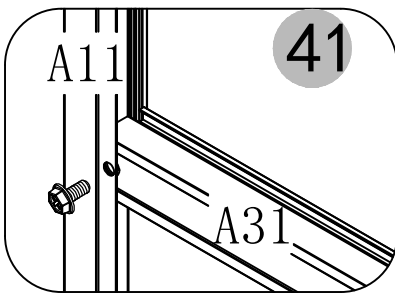
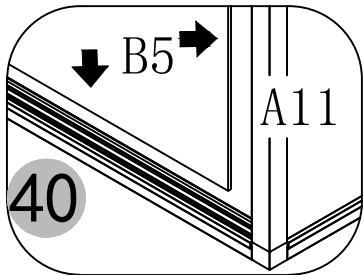
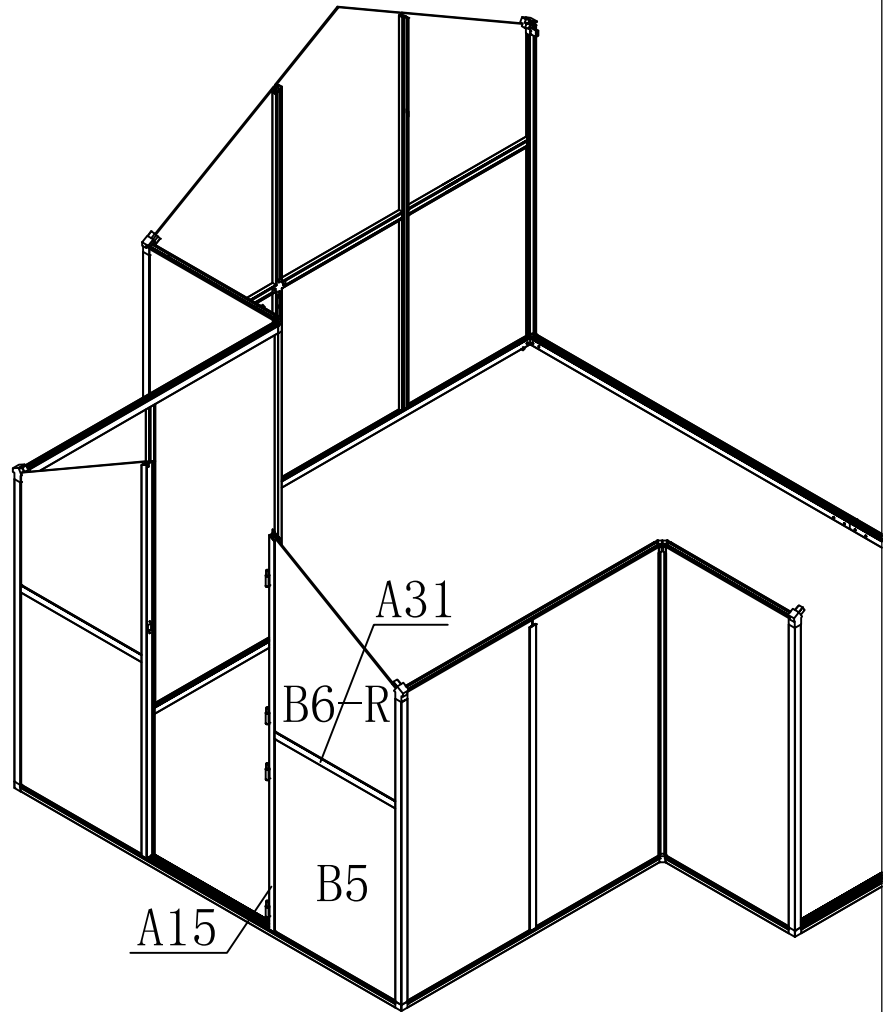

	H10	4pcs
	Z15	1pc



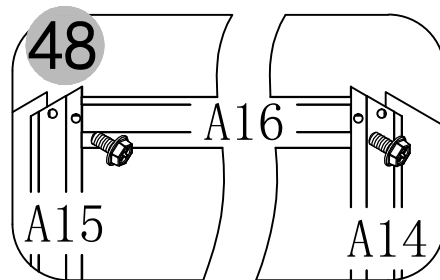
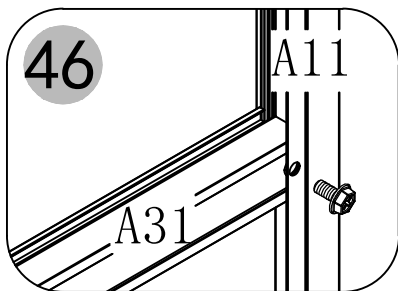
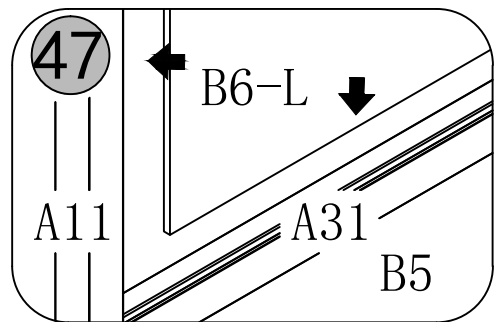
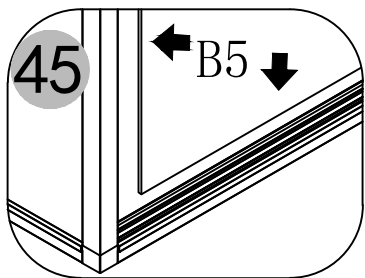
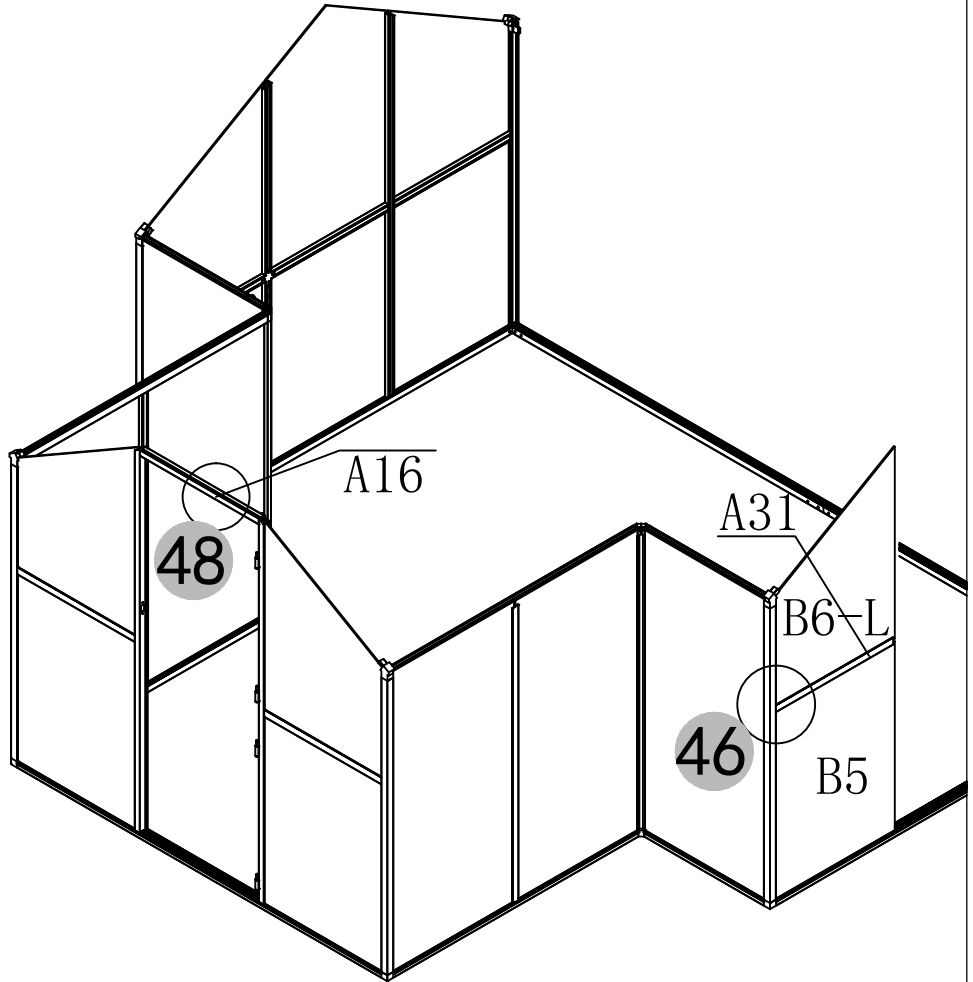

	H10	3pcs
---	-----	------



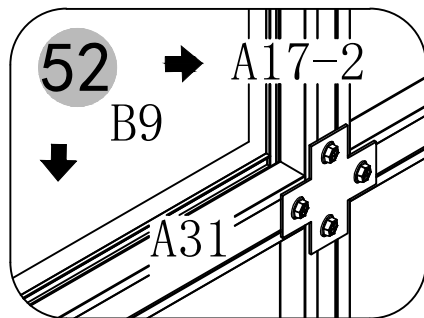
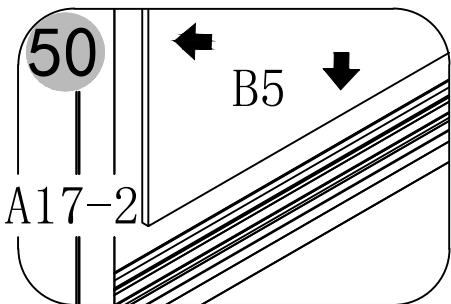
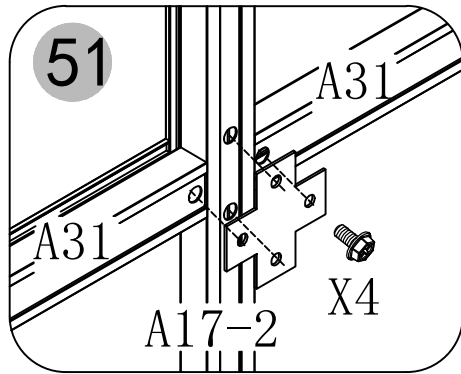
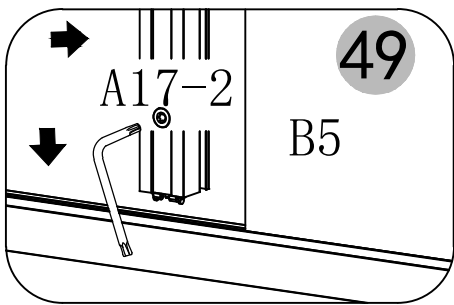
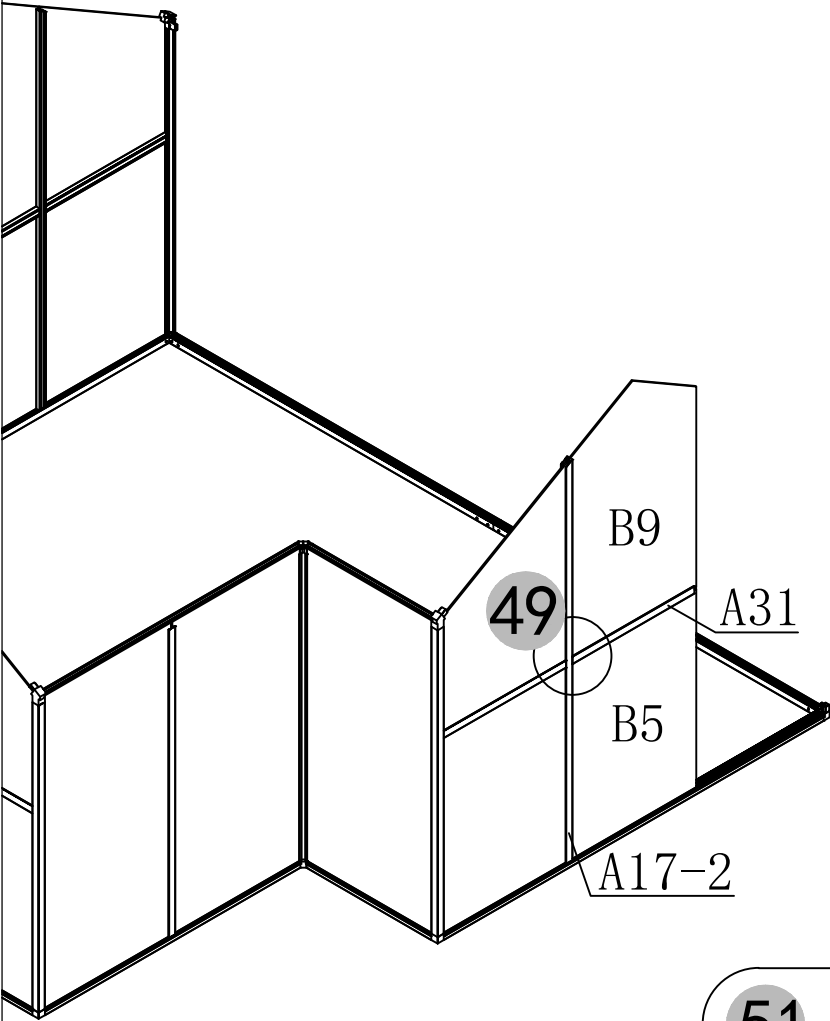



	H10	4pcs
	Z14	1pc

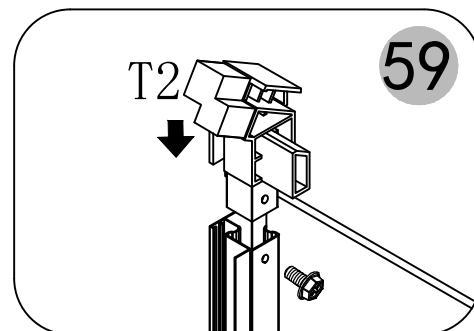
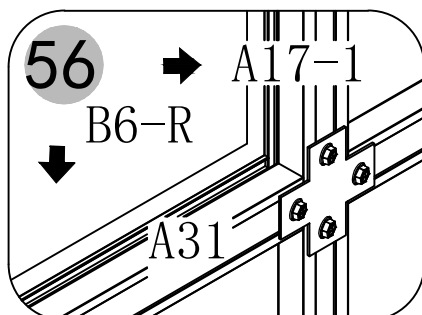
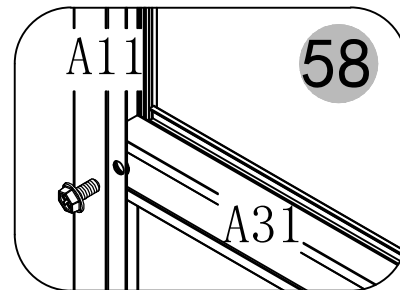
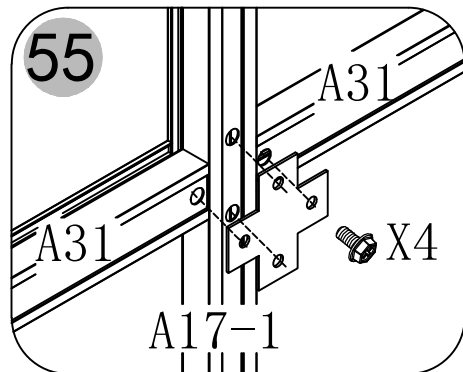
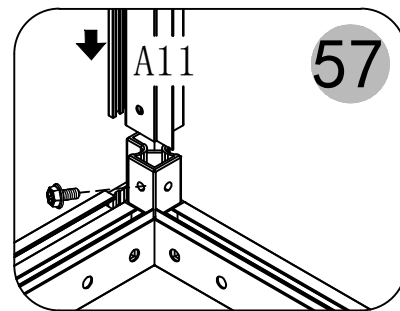
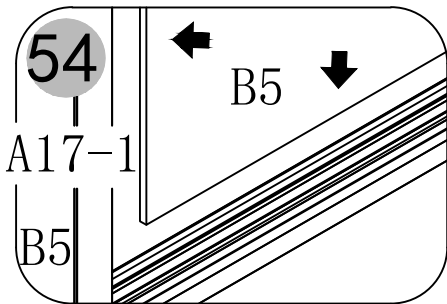
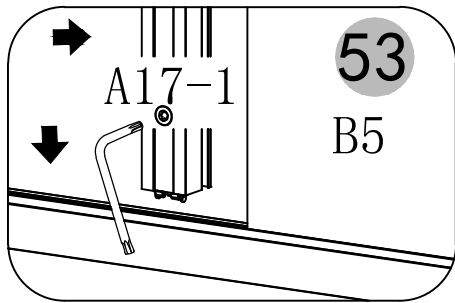
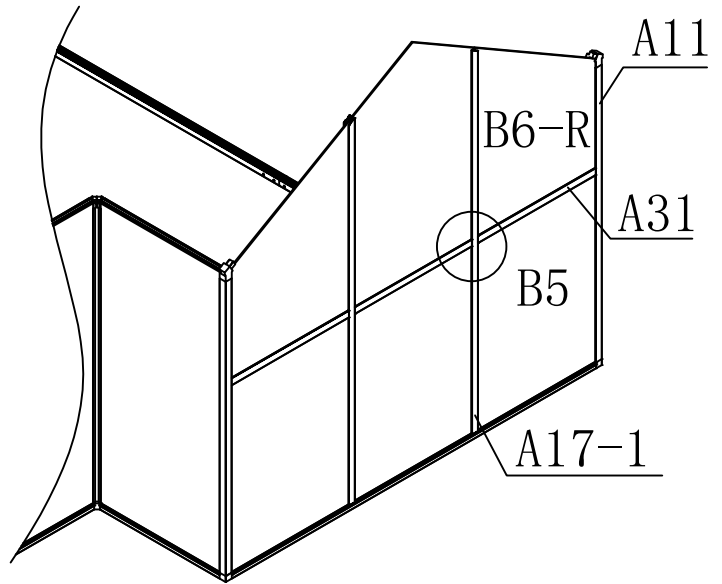

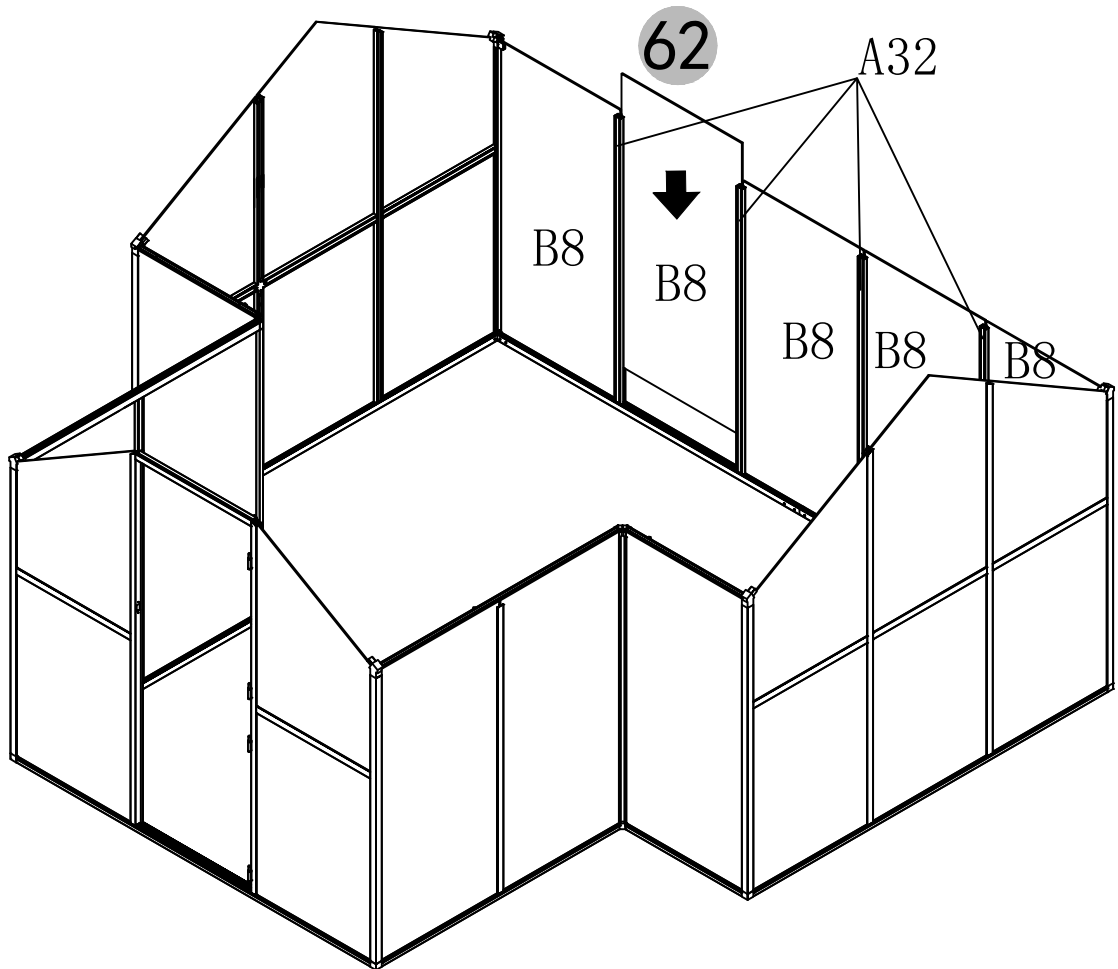
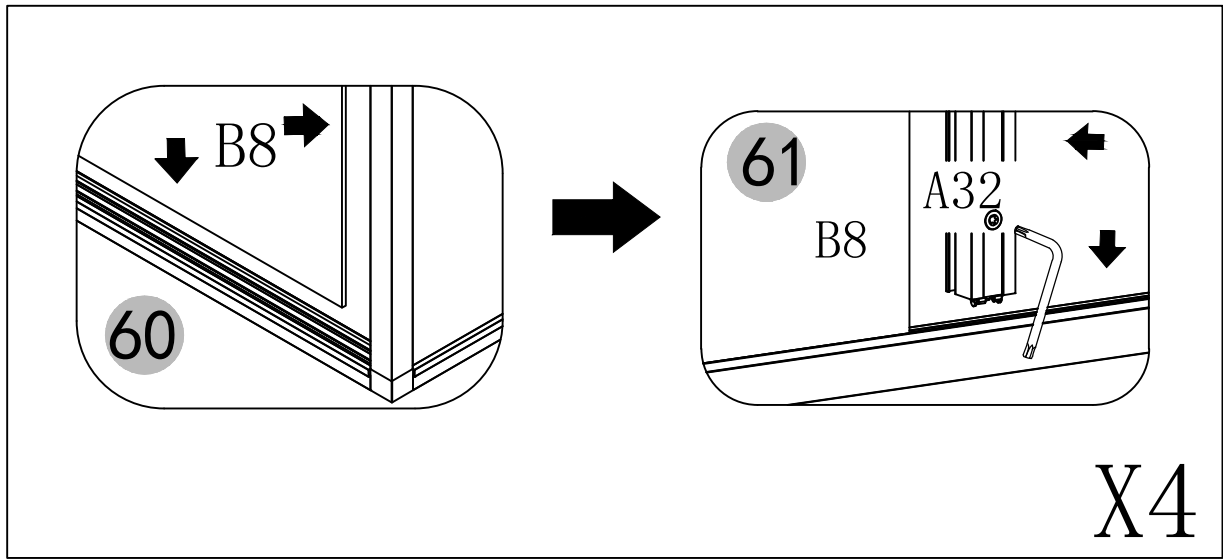

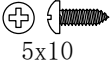

	H10	7pcs
	Z14	1pc
	T2	1pc



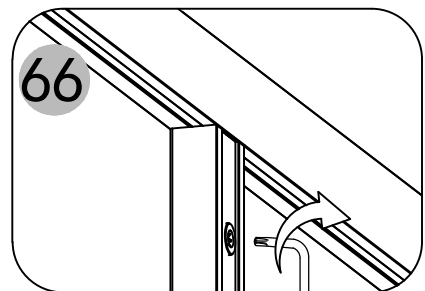
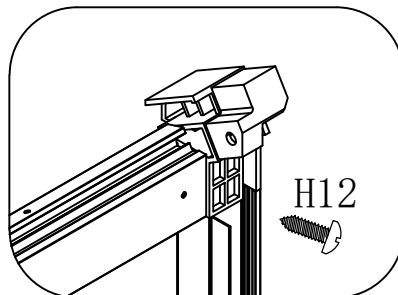
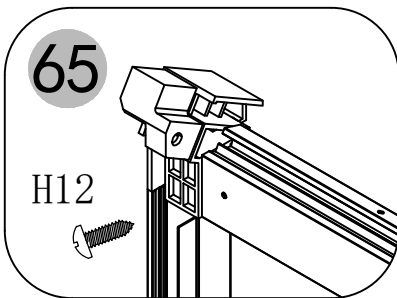
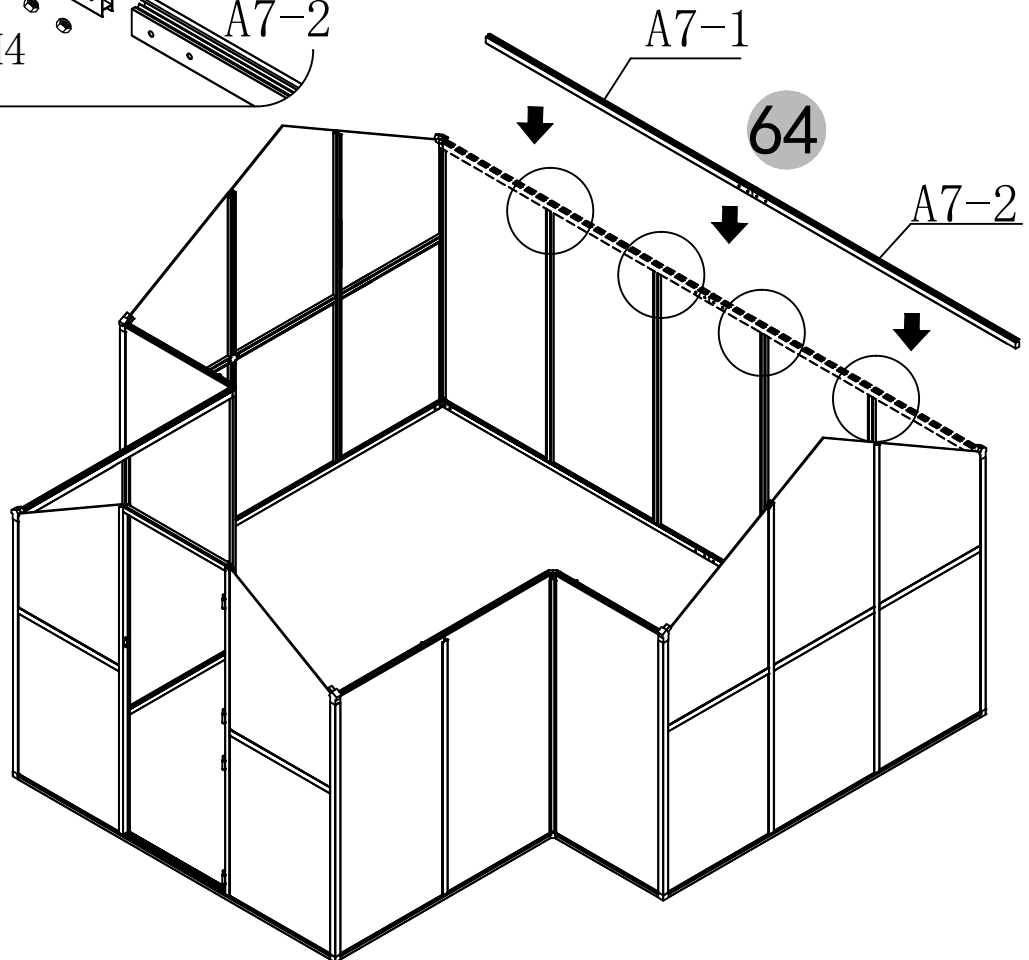
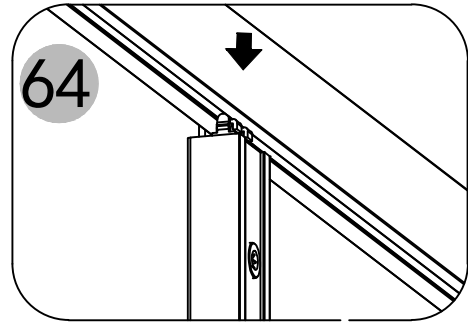
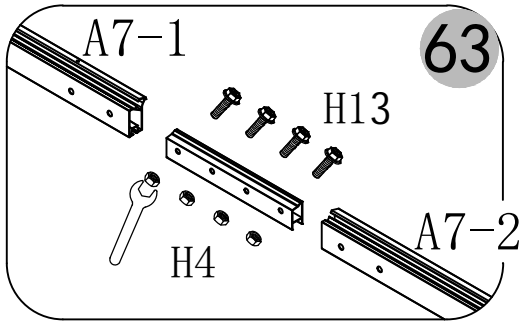

	A28	1pc		H12	2pcs
	H13	4pcs			
	H4	4pcs			



	H10	18pcs
	T4	3pcs
	Z17	3pcs

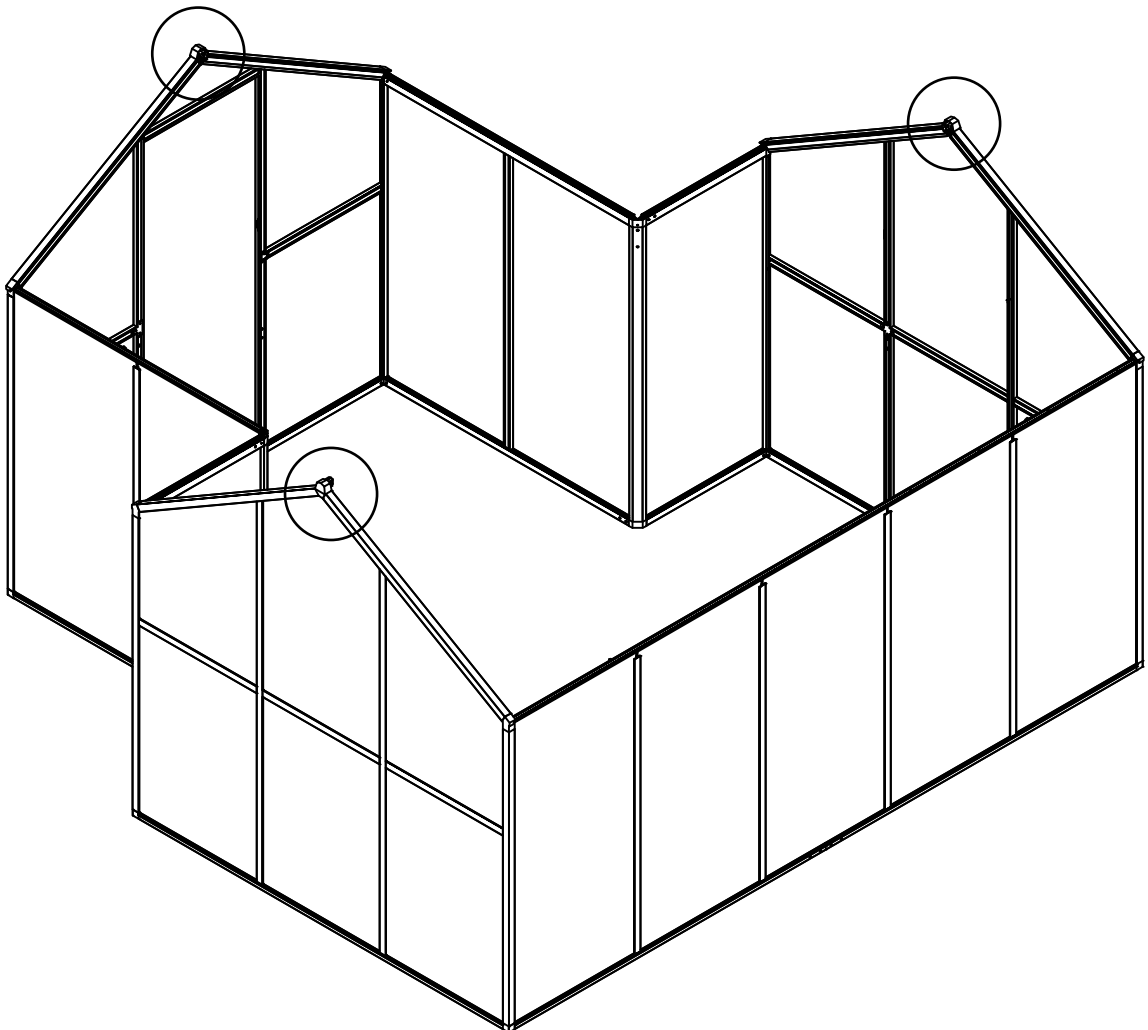
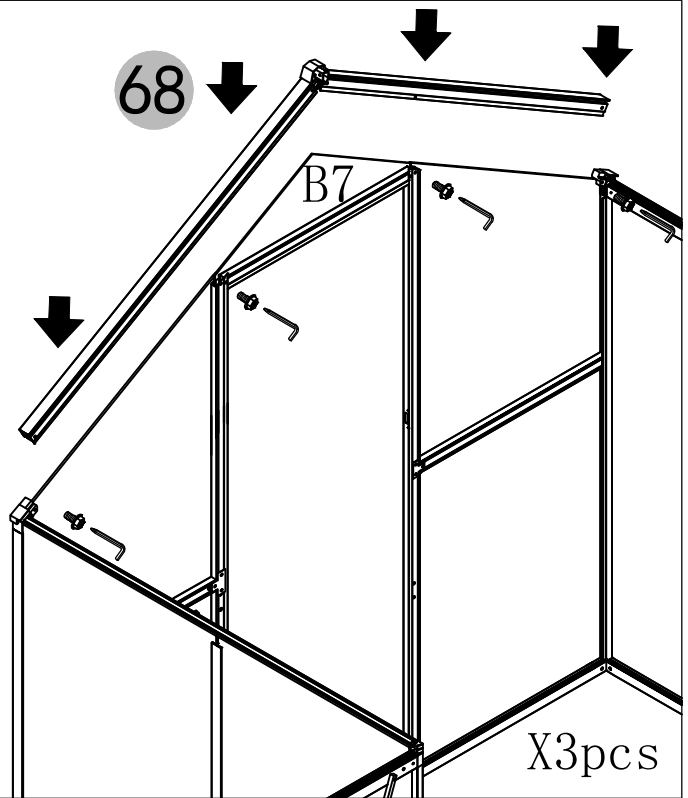
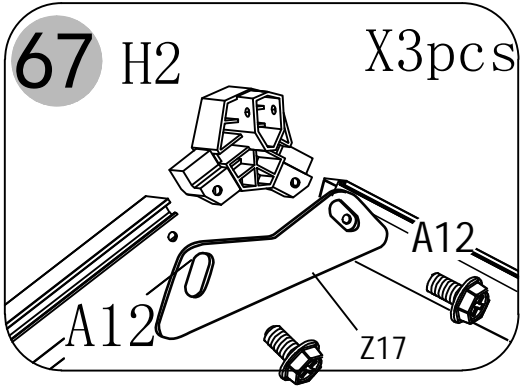

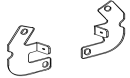

Z18 3pcs

Before installing the Z18, you need to loosen the screws that were previously fixed here (2 x H10, 1 x H12)

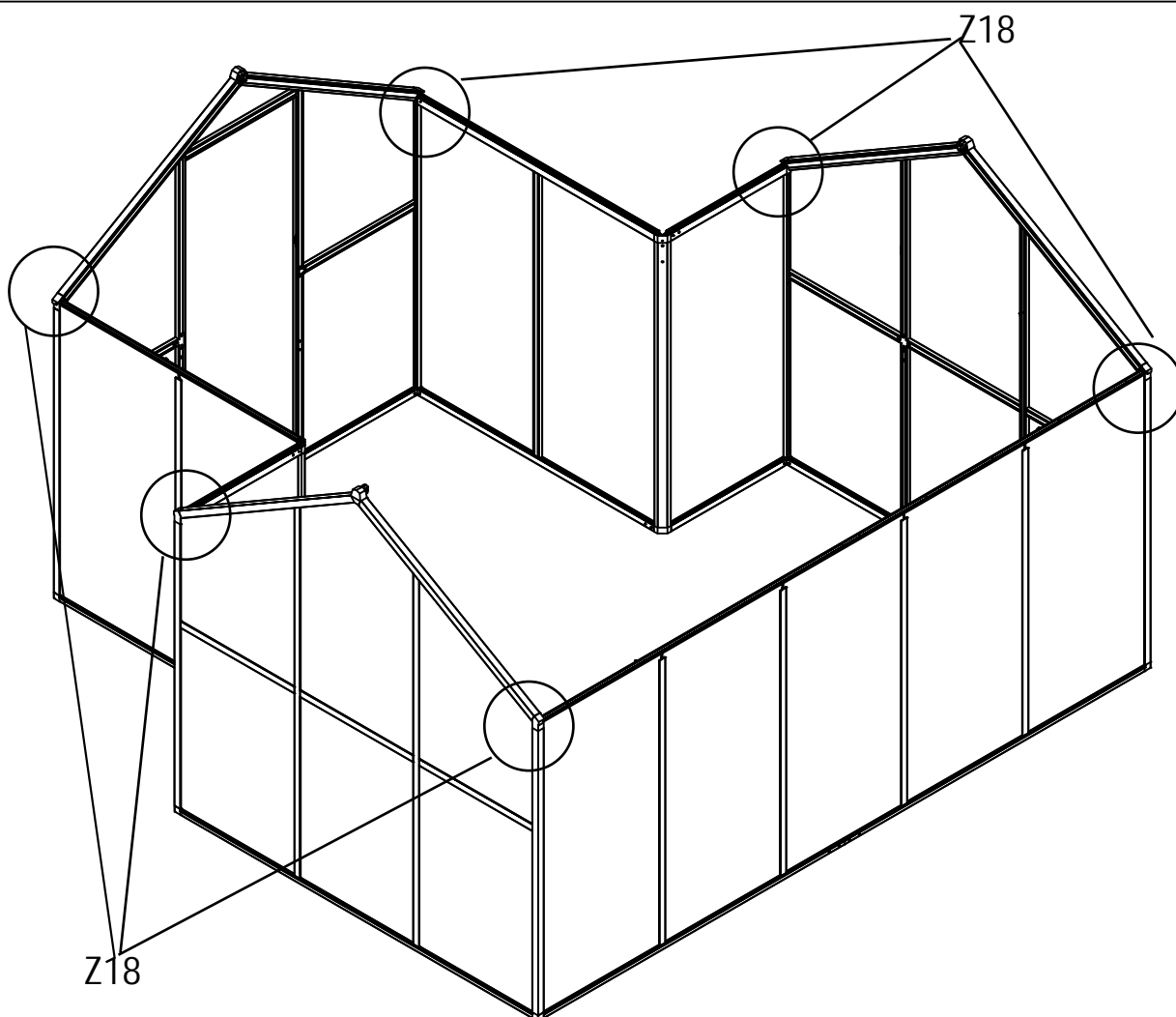
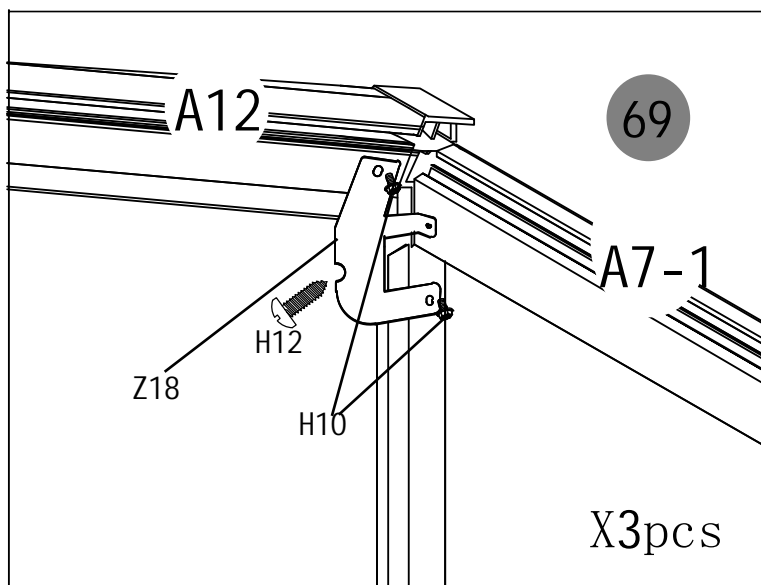







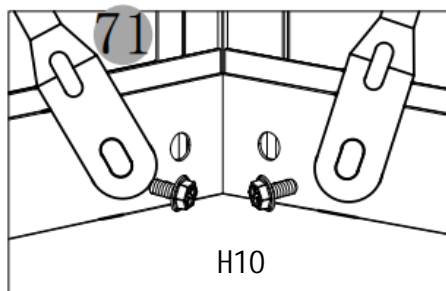
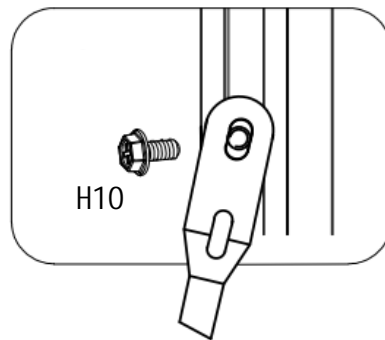
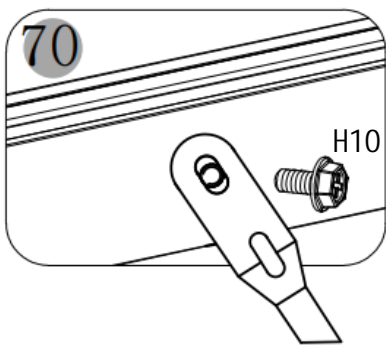
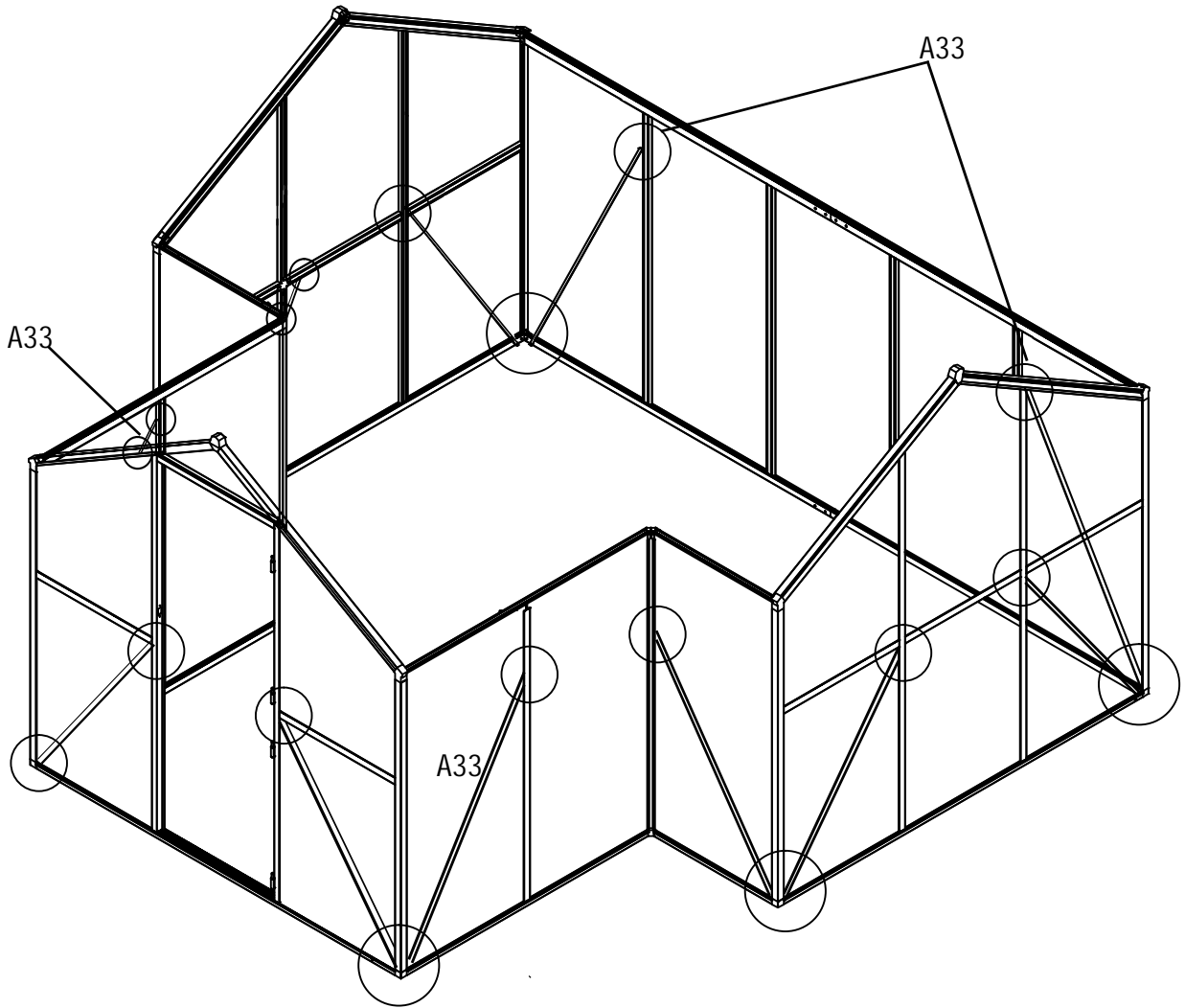

H10





24pcs

The 4 long support bars are A33 and the other 8 are A34

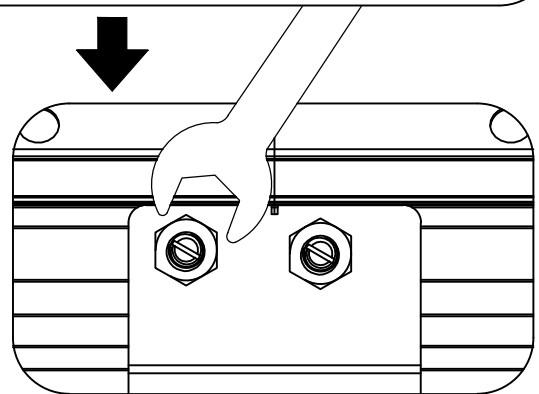
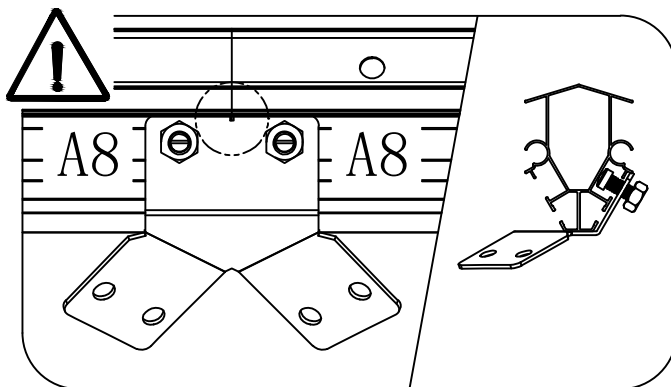
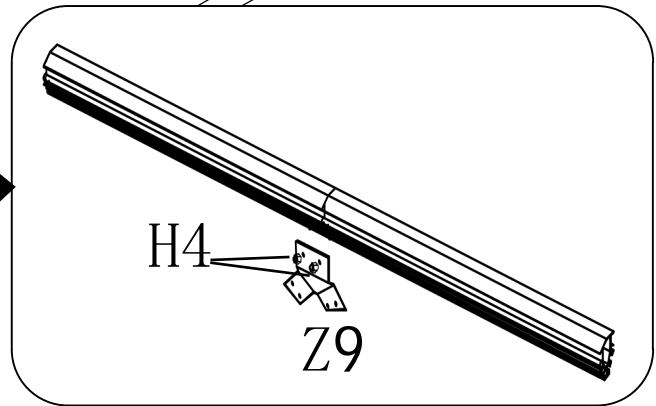
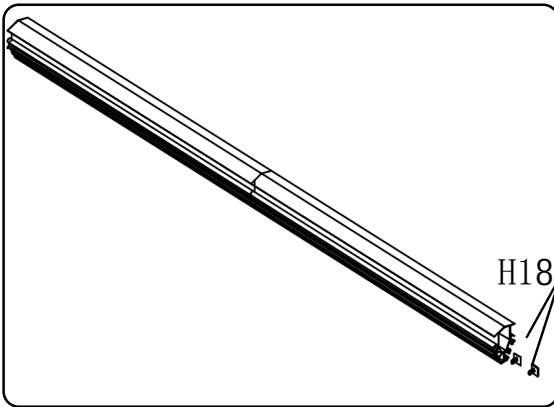
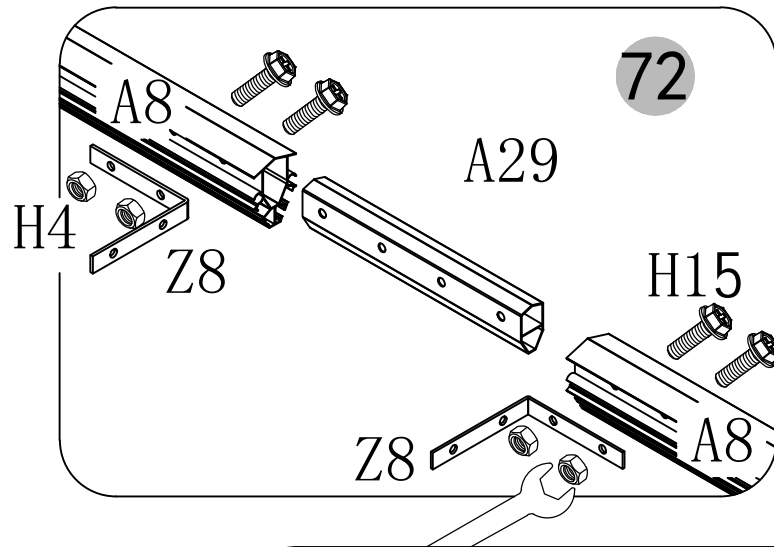
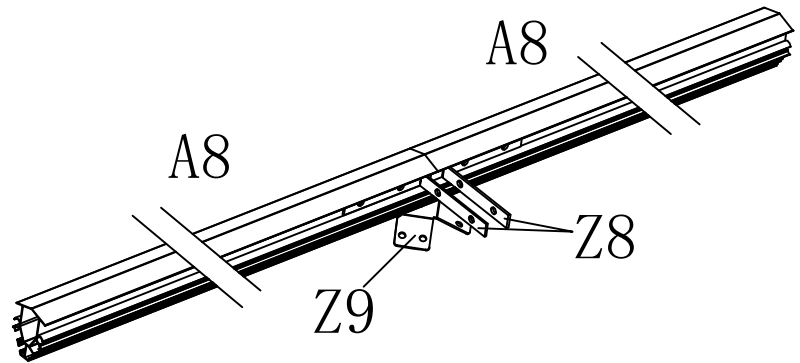



 M6x35	H15	4pcs
 M6	H4	6pcs
	Z8	2pcs
	Z9	1pc
	H18	2pcs
	A29	1pc



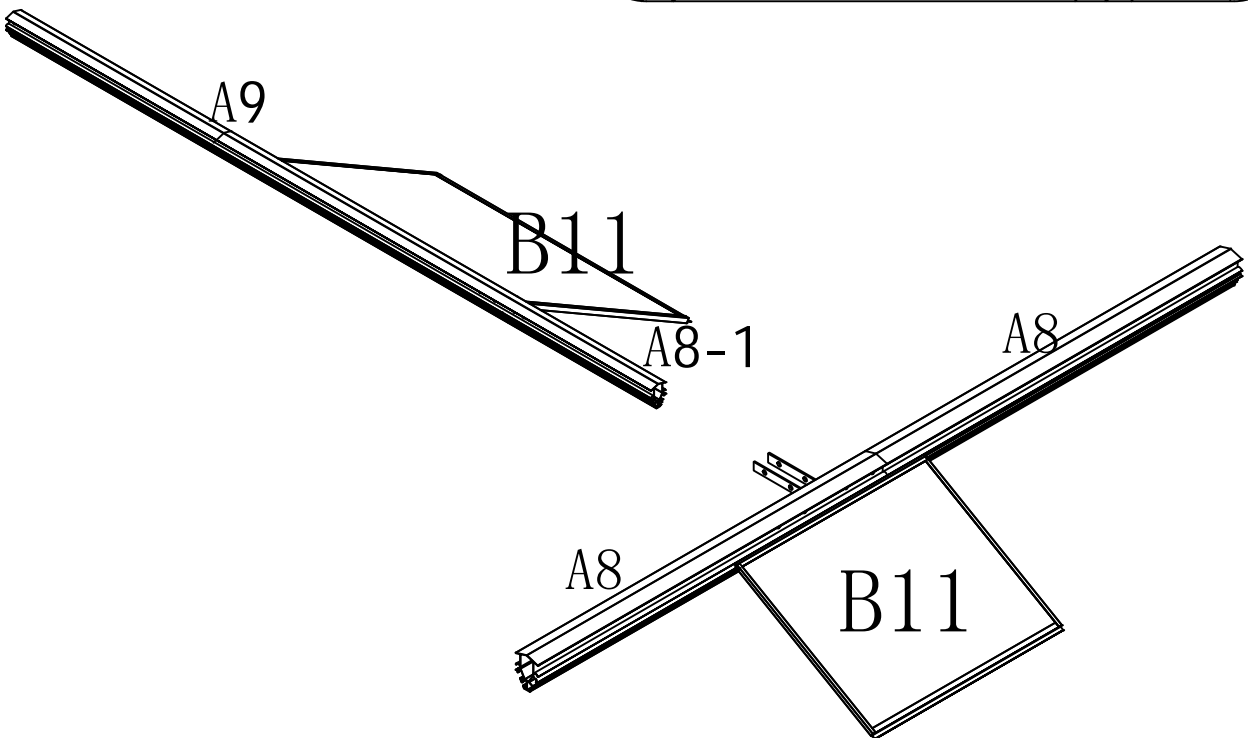
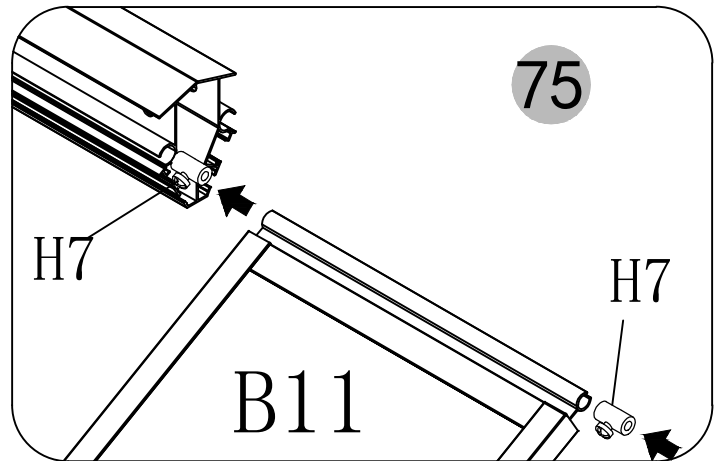
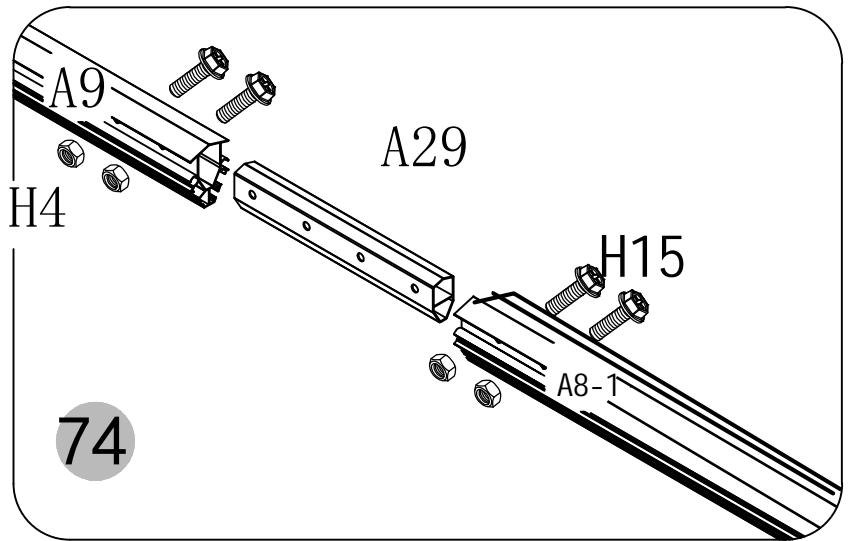

	H7	4pcs
	A29	1pc
 M6x35	H15	4pcs
 M6	H4	4pcs

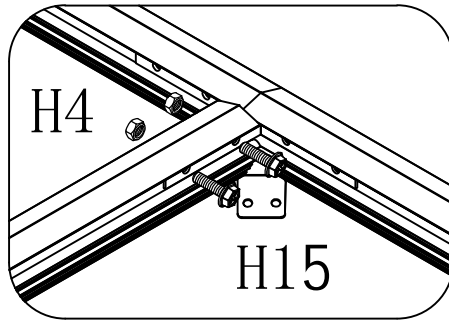
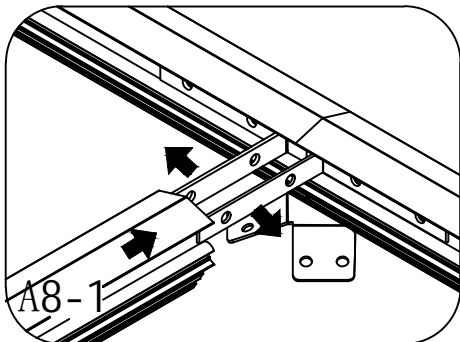
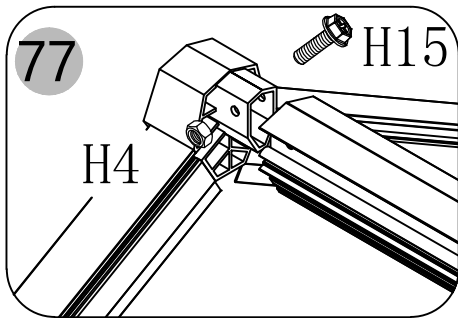
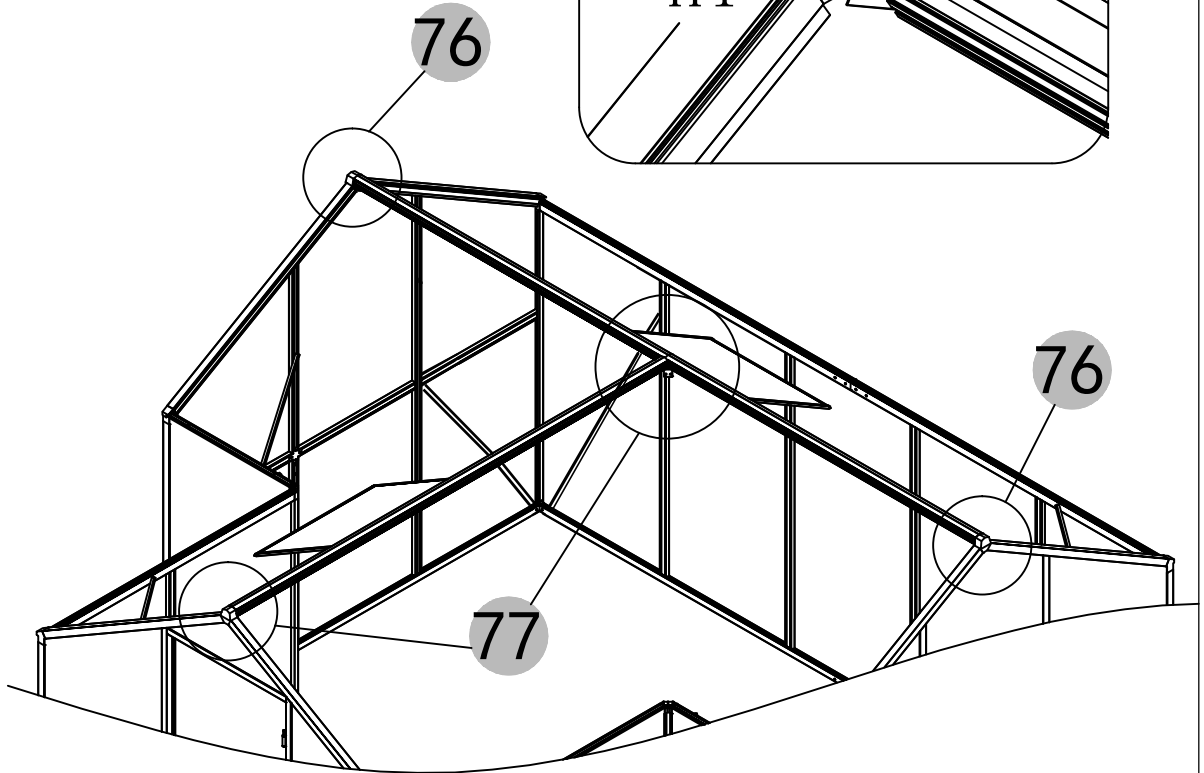
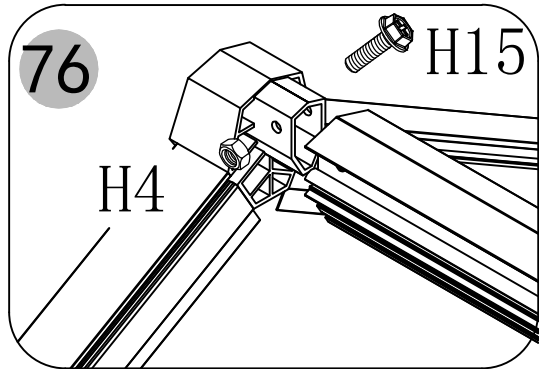

 M6x35	H15	5pcs
 M6	H4	5pcs



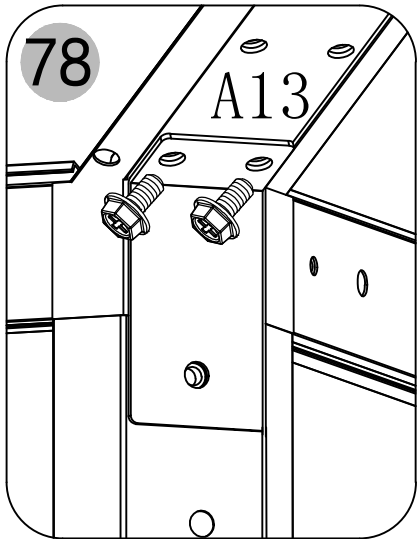
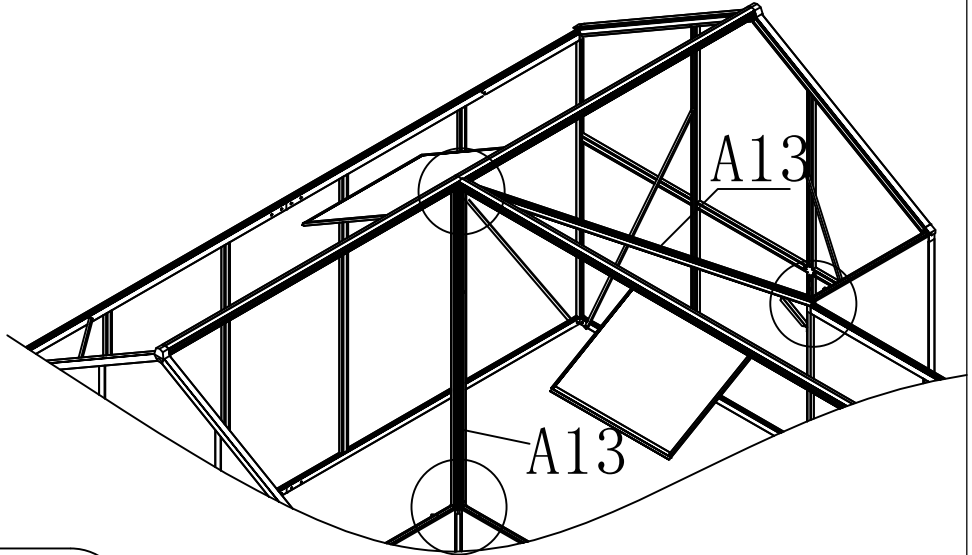

	H10	14pcs
	Z13	2pcs



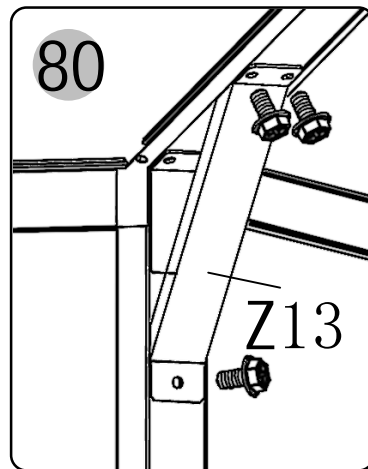
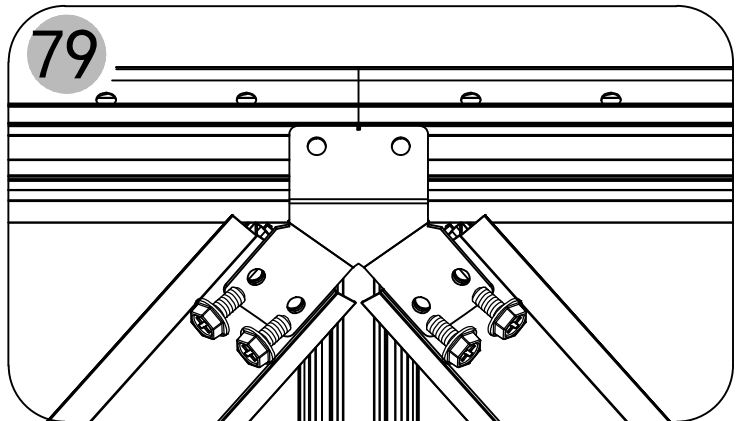

X2



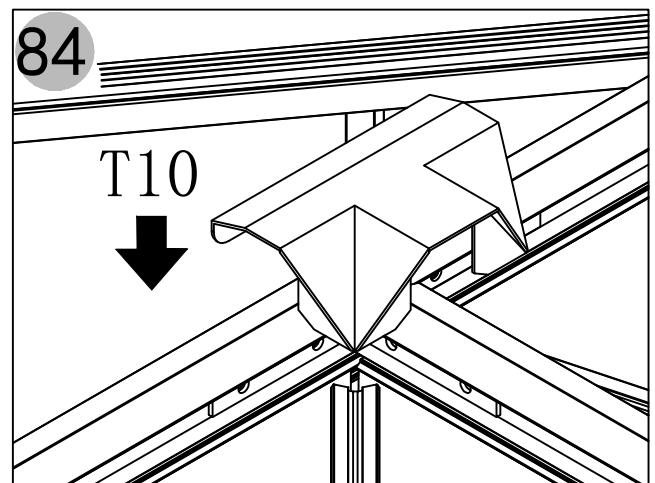
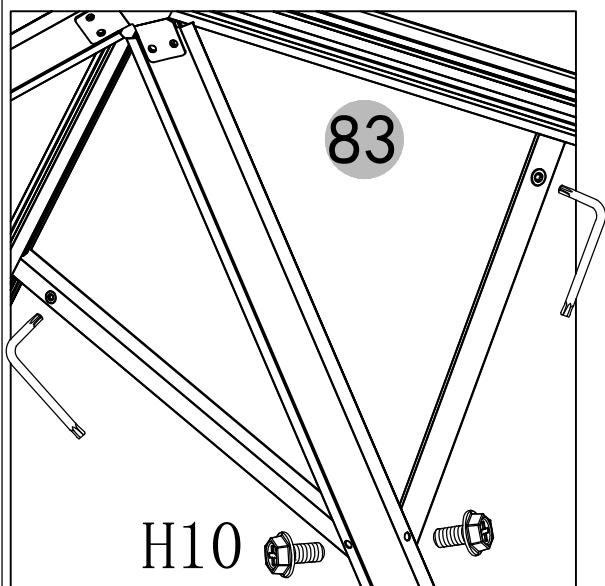
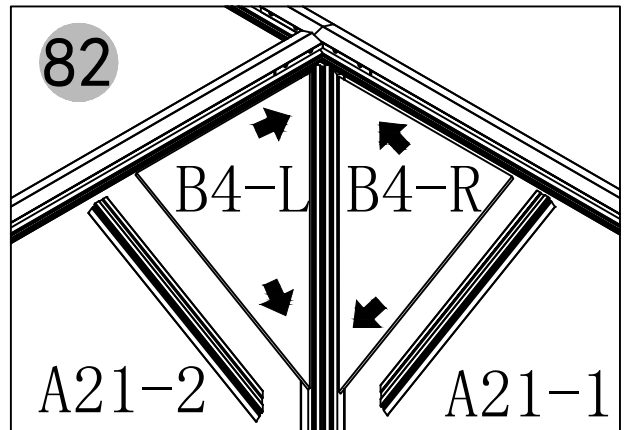
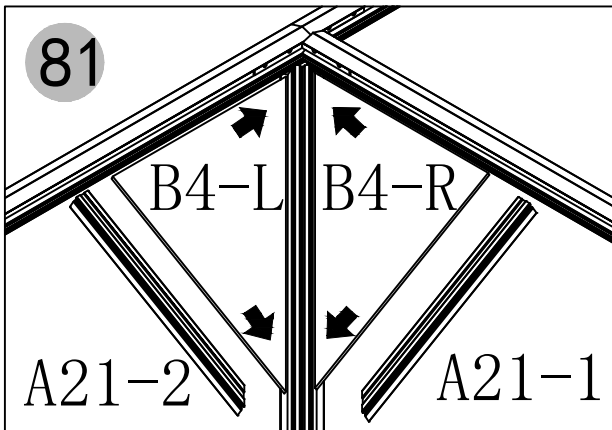
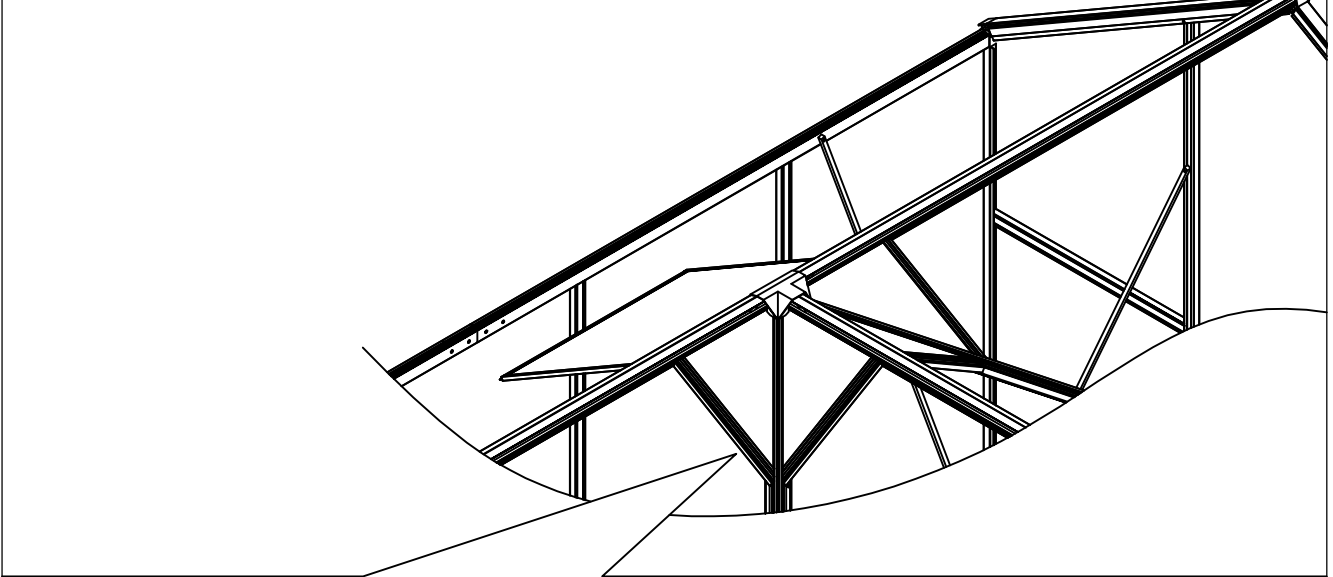

X2

	H10	4pcs
	T10	1pc



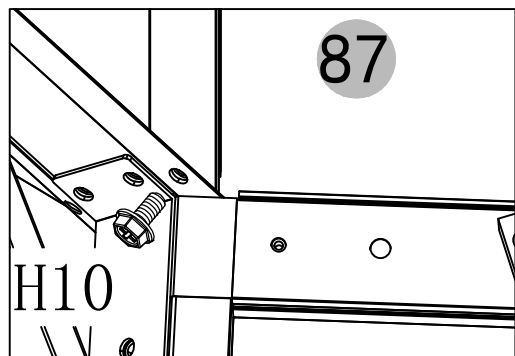
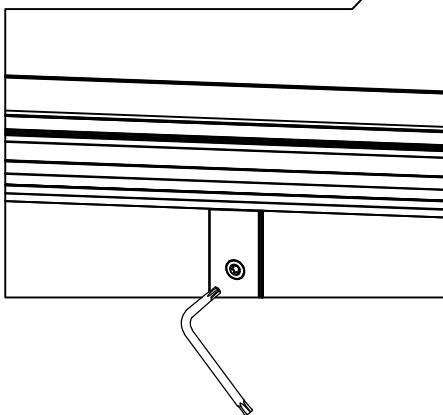
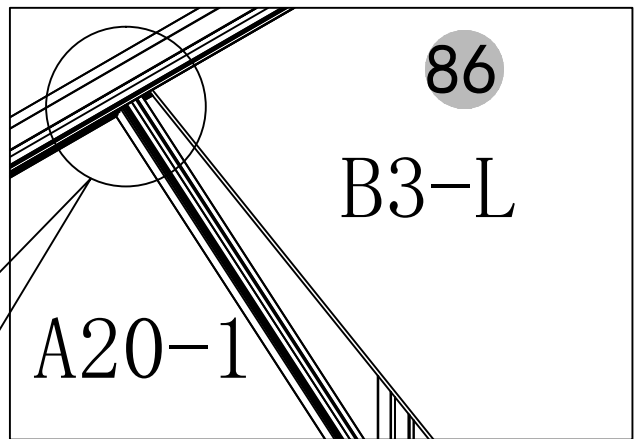
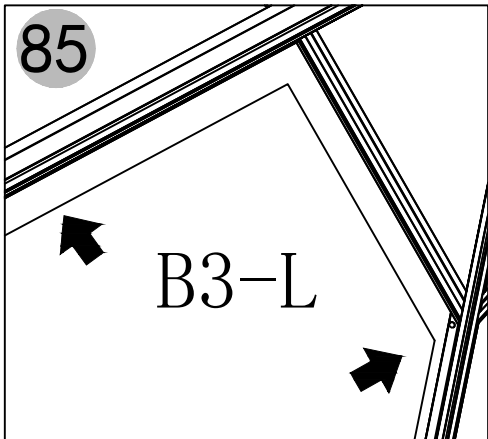
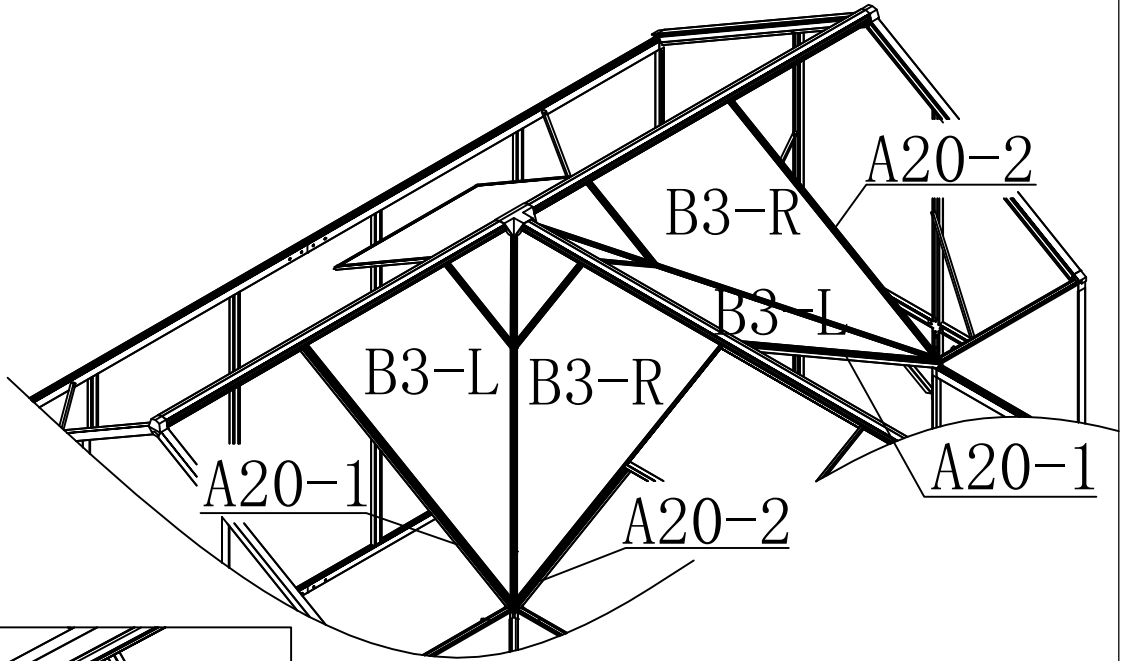

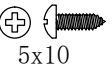
	H10	4pcs
---	-----	------



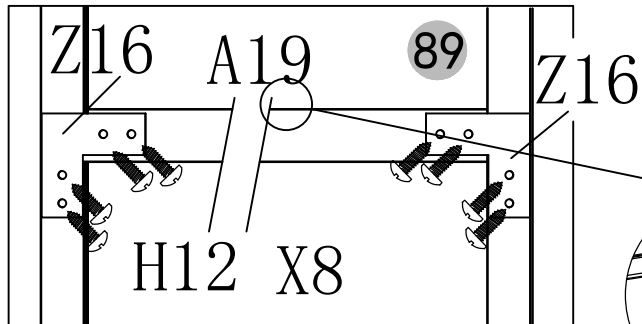
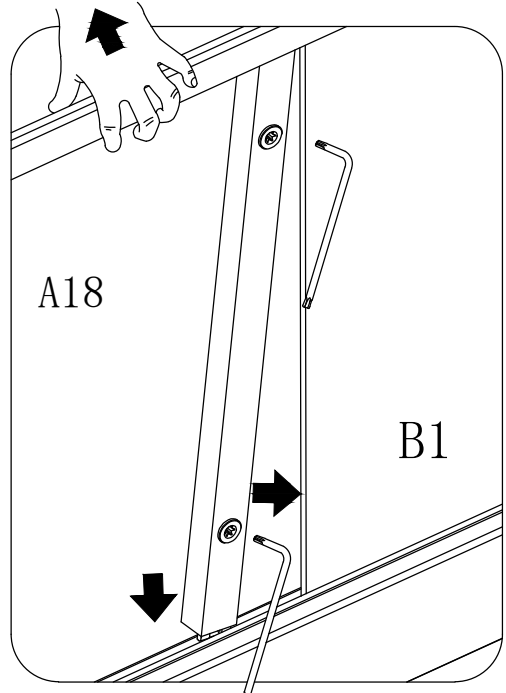
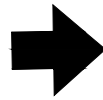
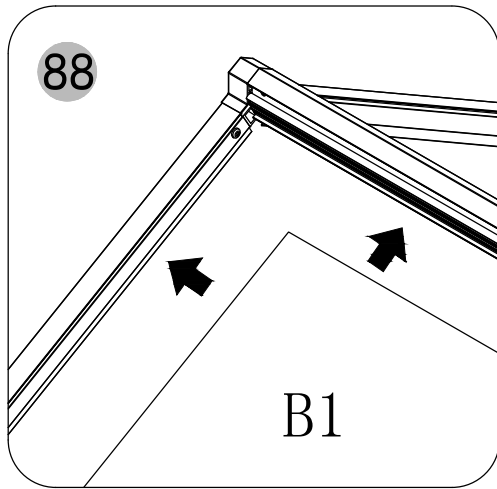
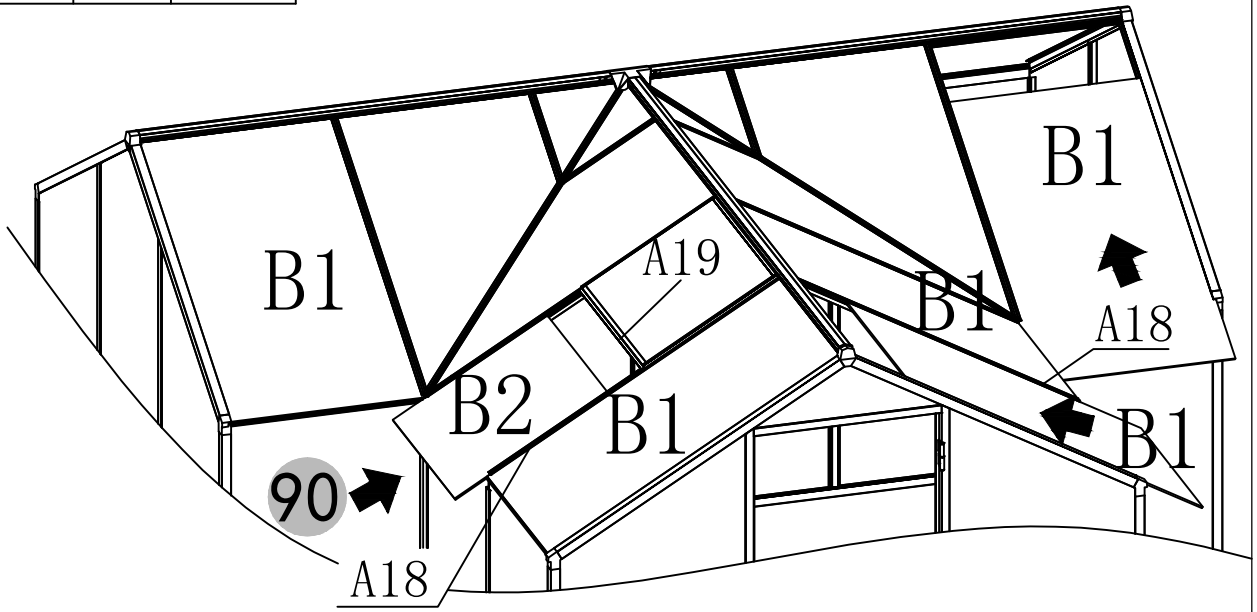

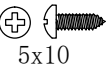
 5x10	H12	8pcs
	Z16	2pcs



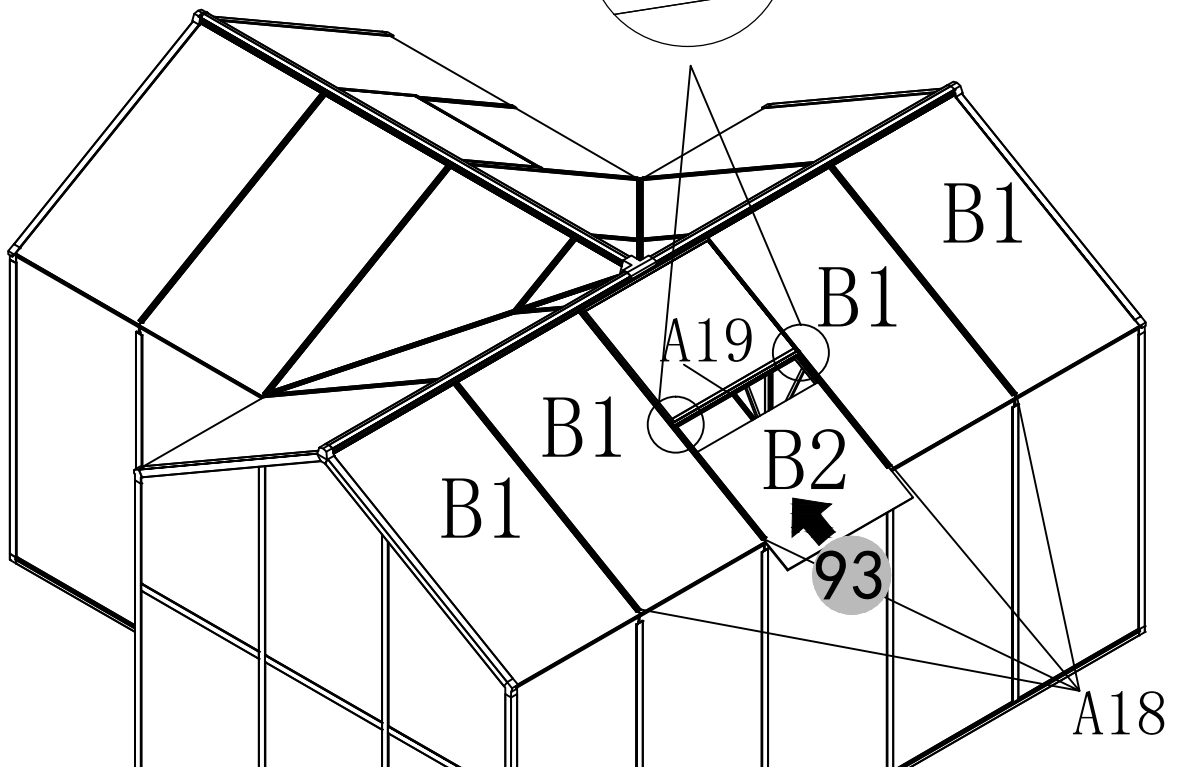
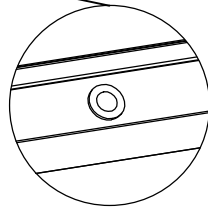
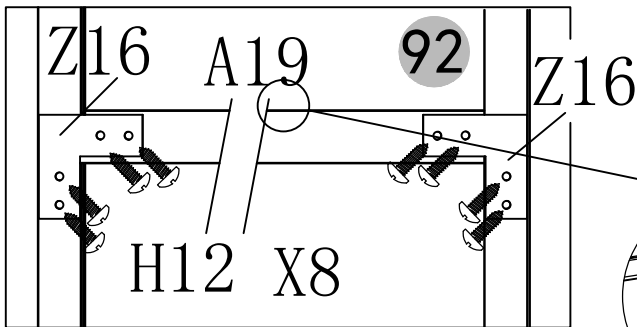
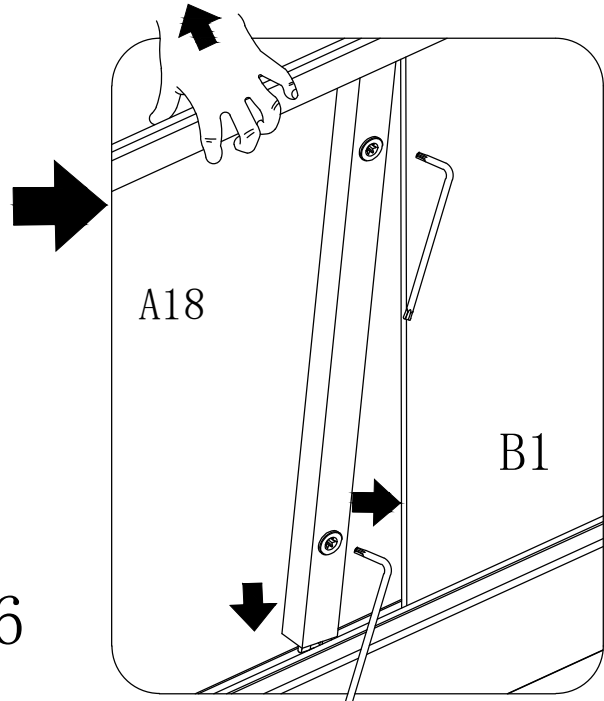
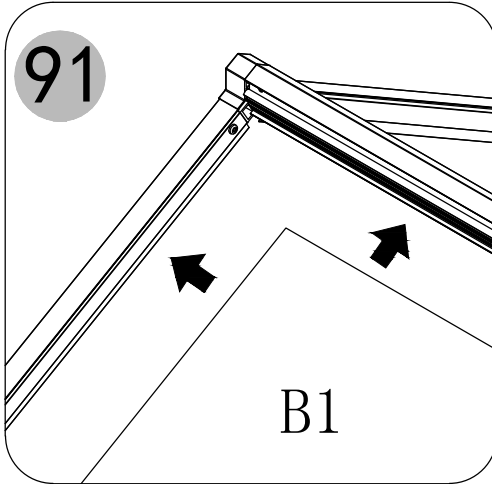

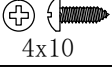
 5x10	H12	8pcs
	Z16	2pcs



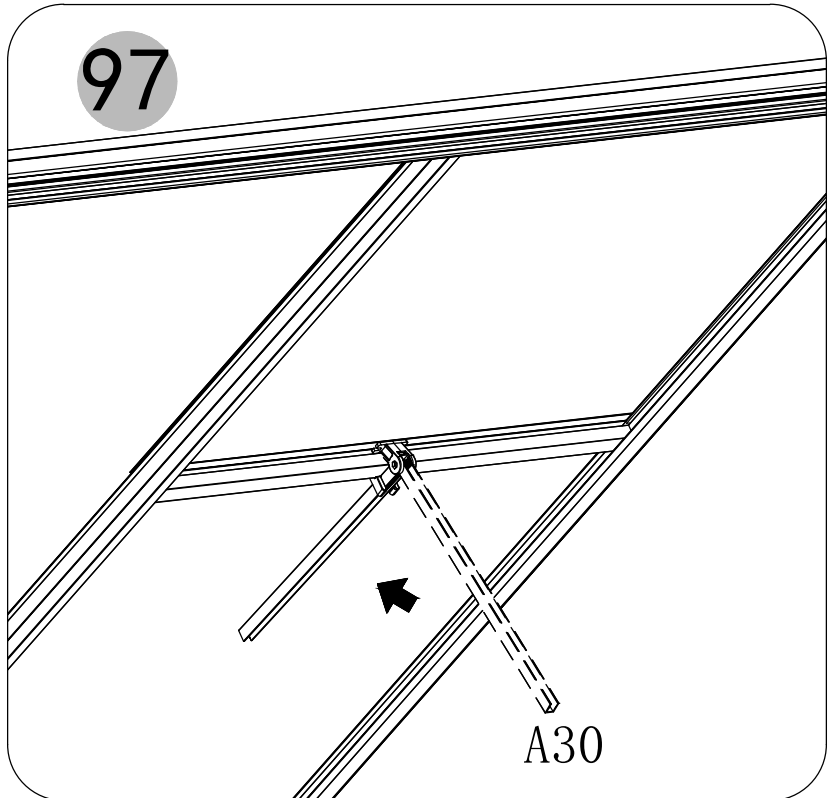
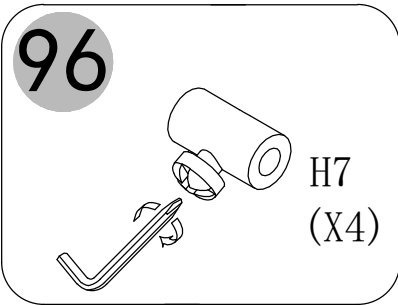
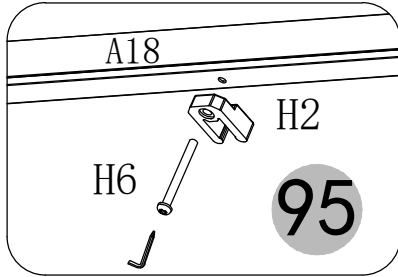
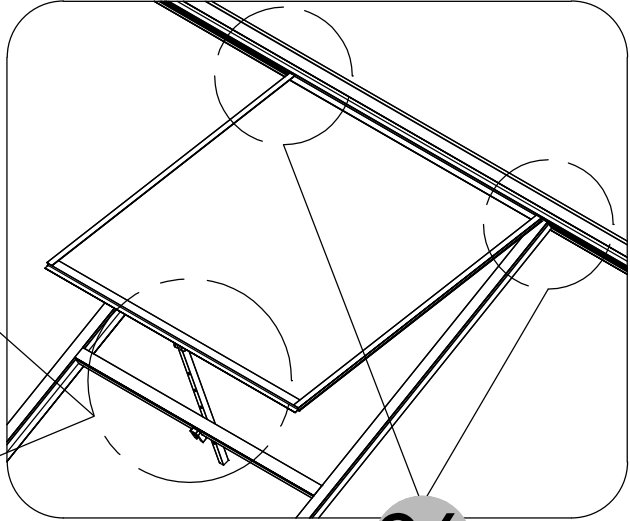
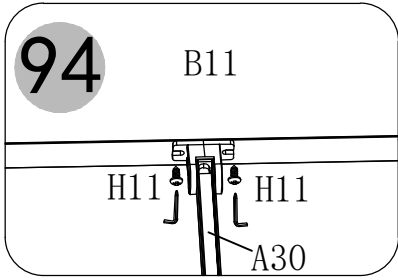



	H2	2pcs		H11	4pcs
	H6	2pcs			

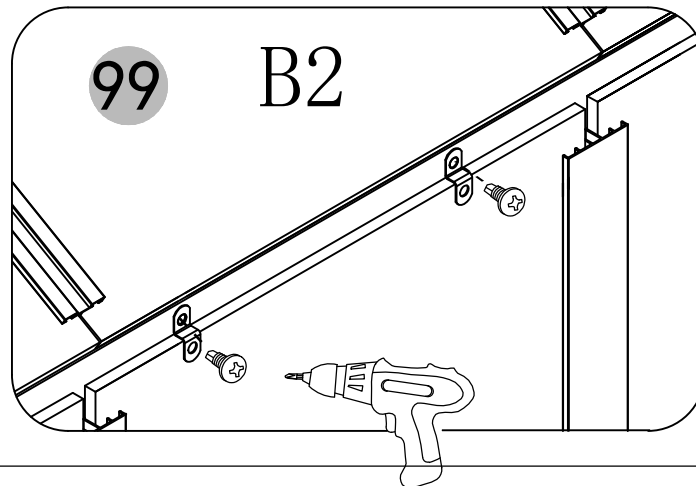
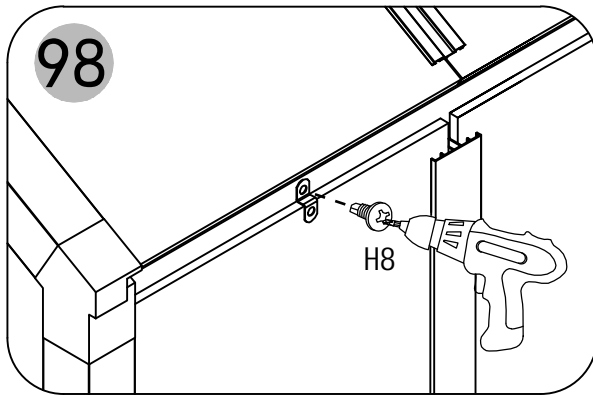
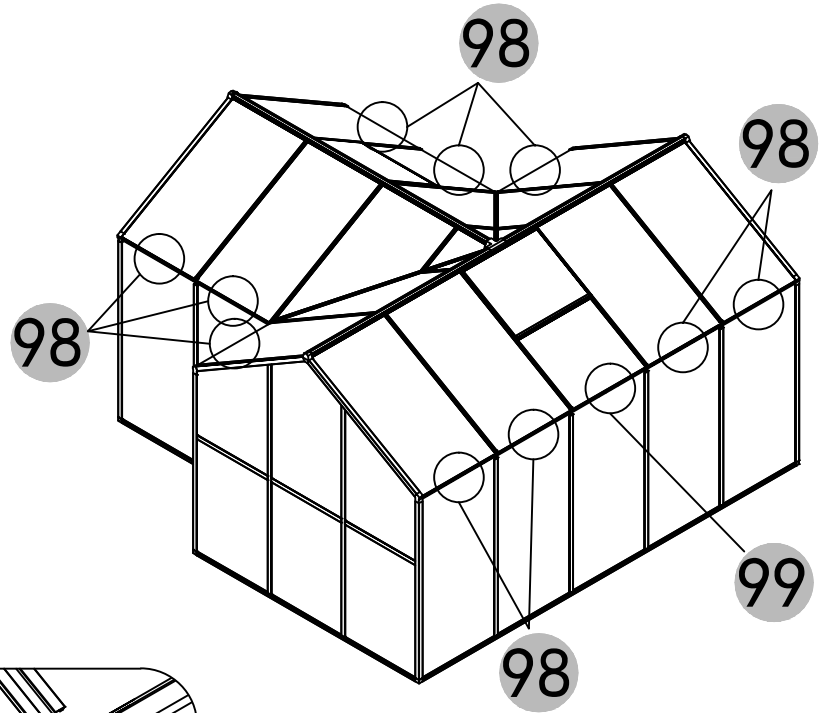



 M4X13	H8	12pcs
	H19	12pcs

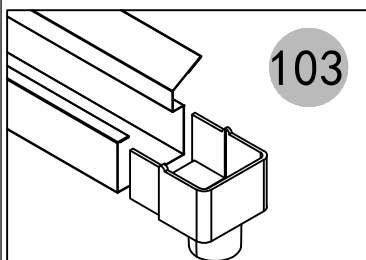
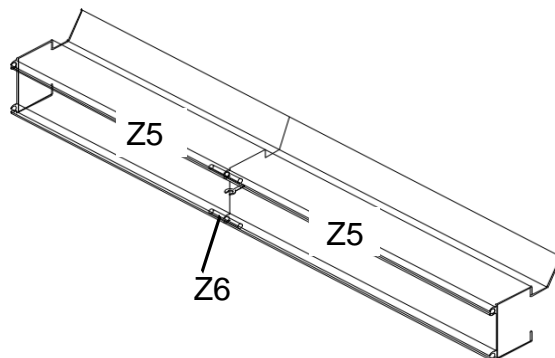
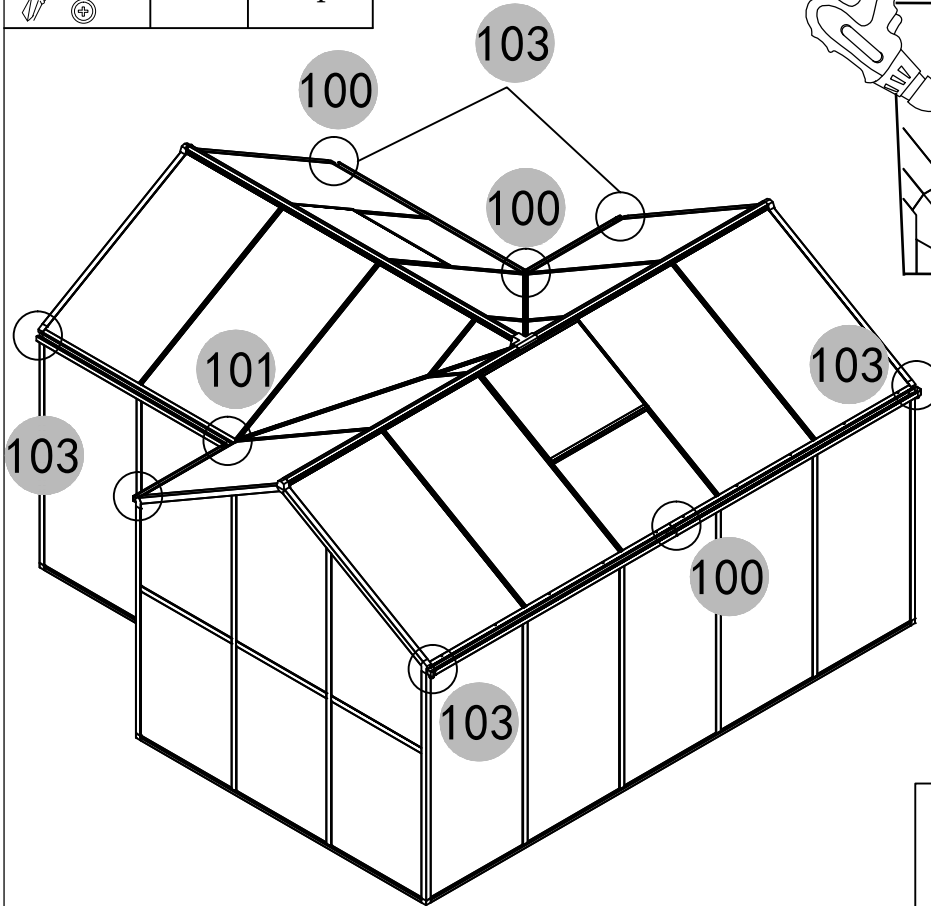
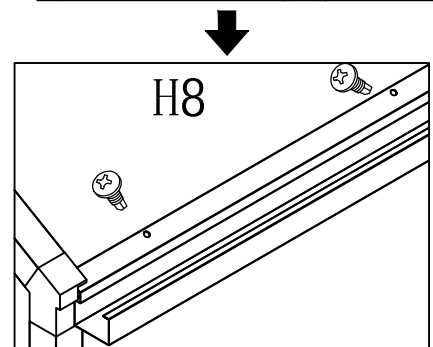
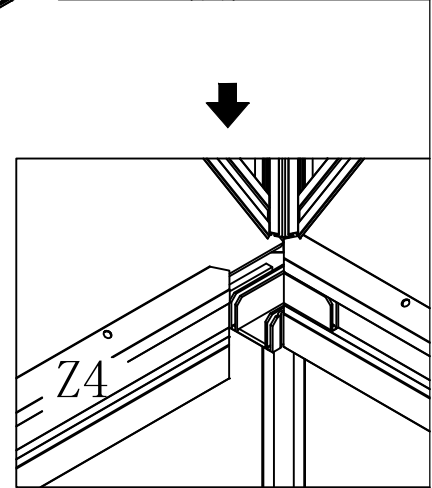
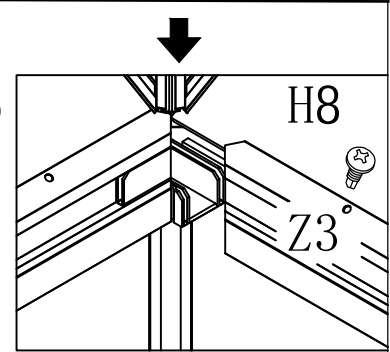
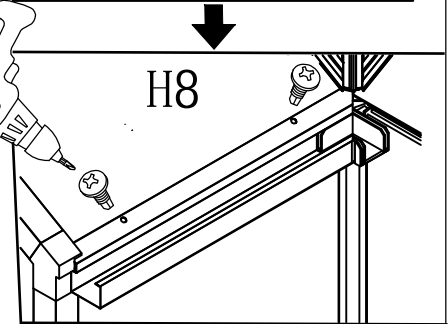
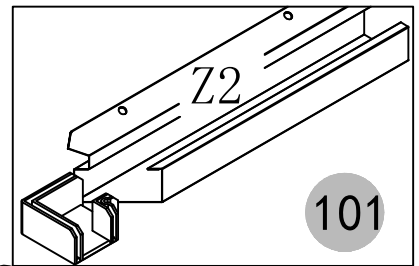
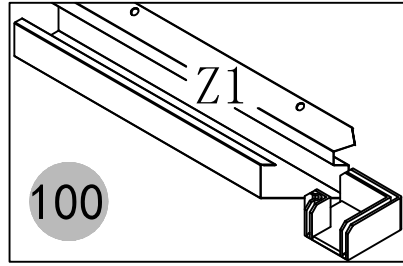

	Z6	2pcs
	T7	6pcs
	T8	2pcs
	H8	22pcs





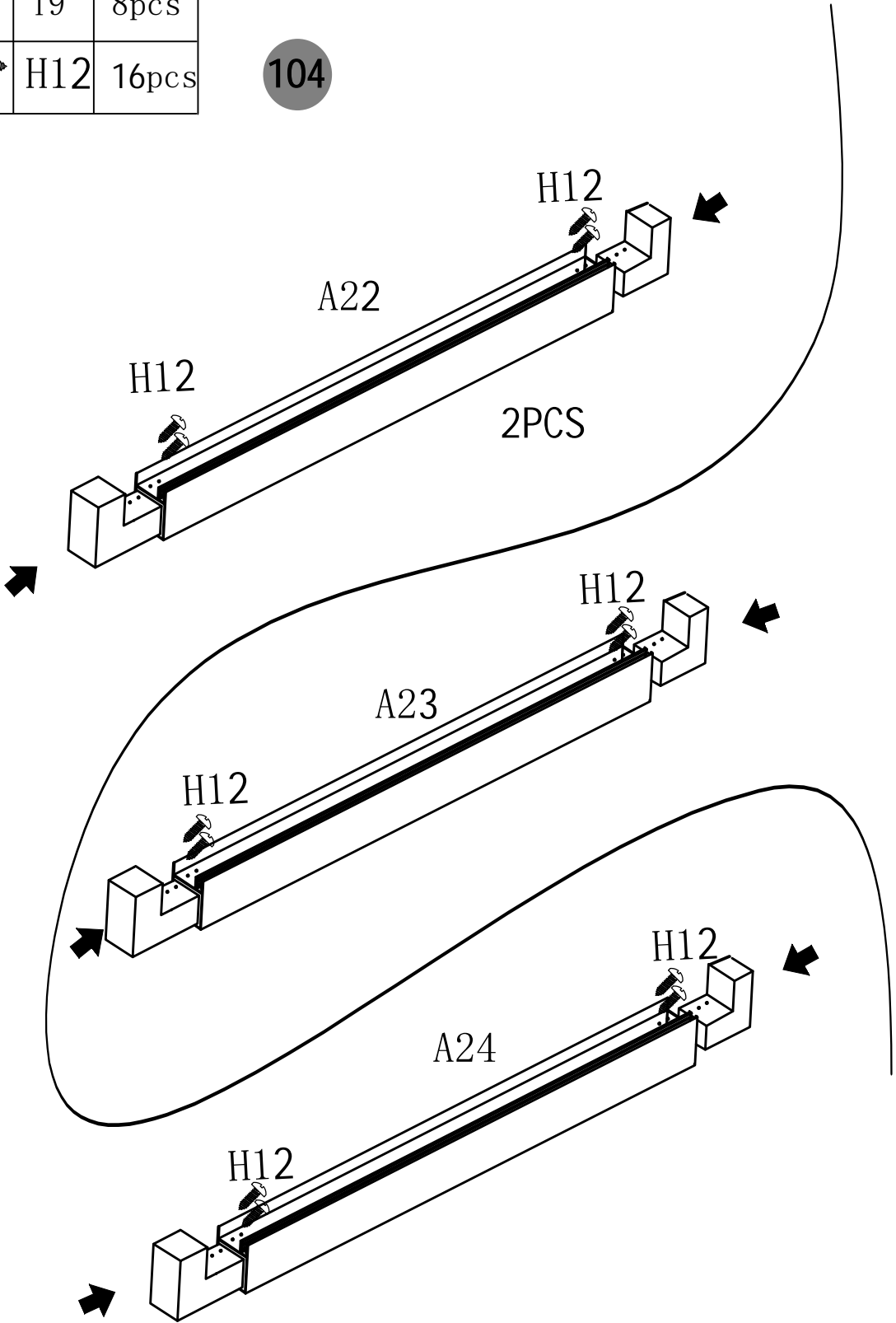

	T9	8pcs
	H12	16pcs

104

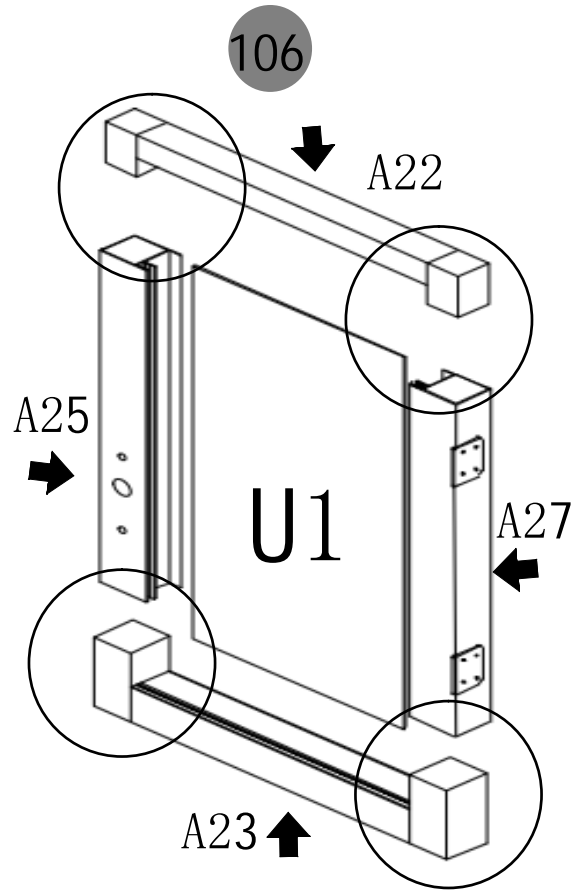
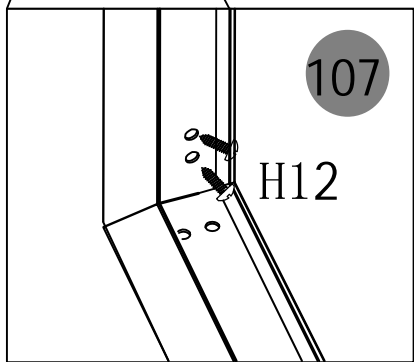
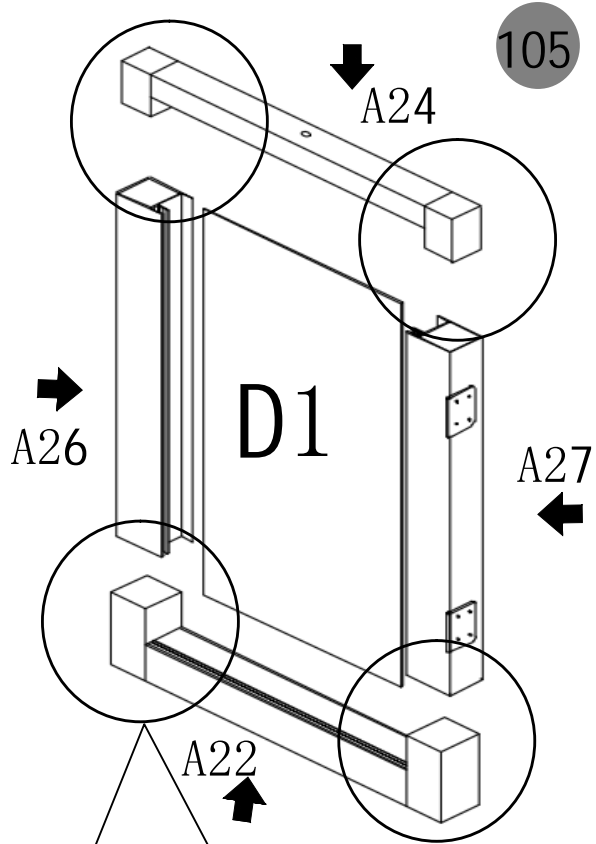

⊕ 5x10 H12 16pcs

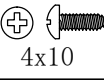

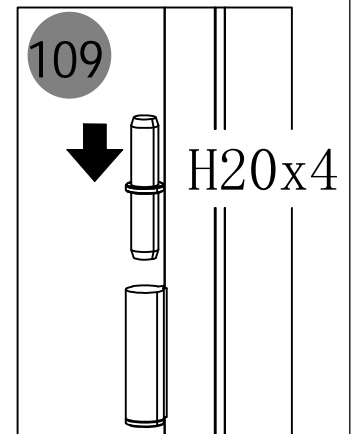
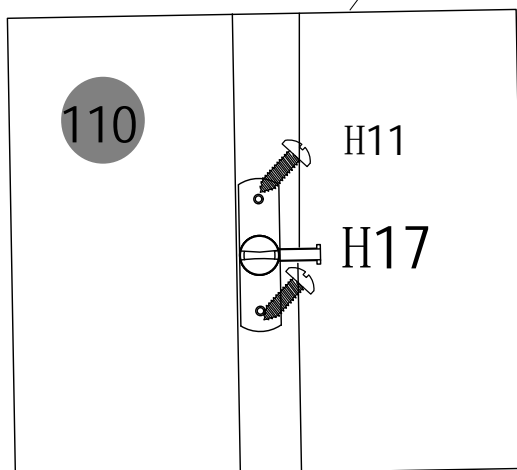
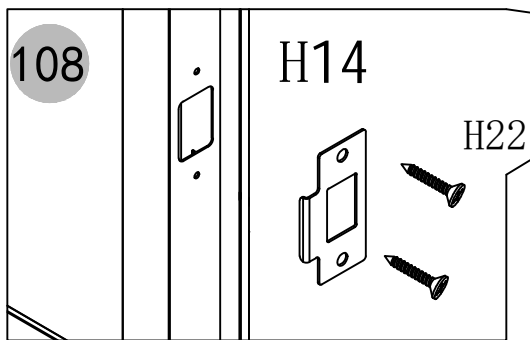
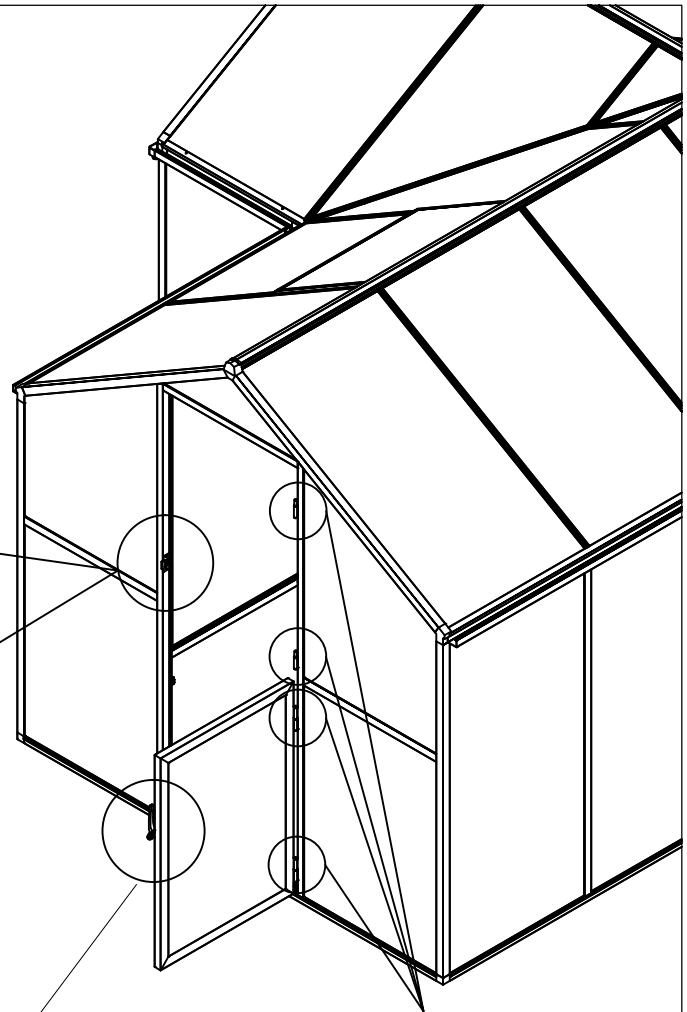

 5X15	H22	2pcs
	H20	4pcs
 4x10	H11	2pcs
	H17	1pc
	H14	1pc

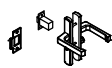

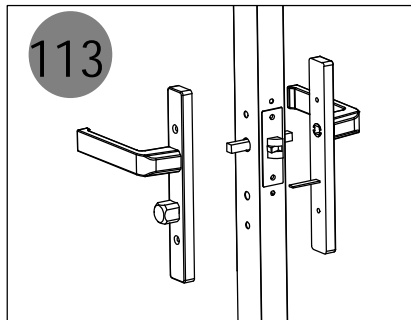
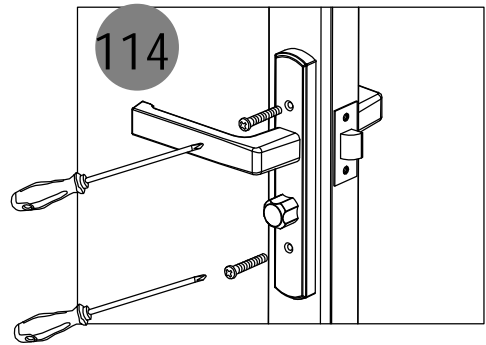
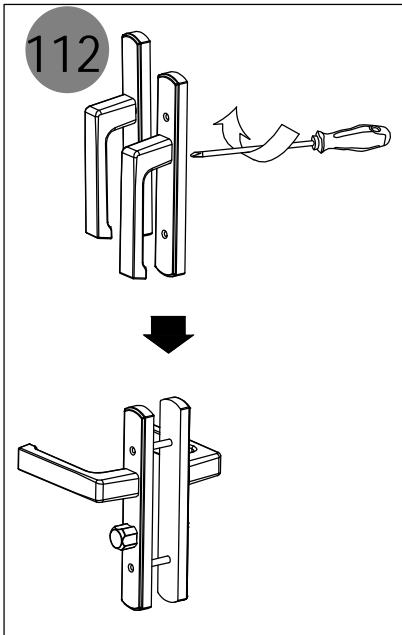
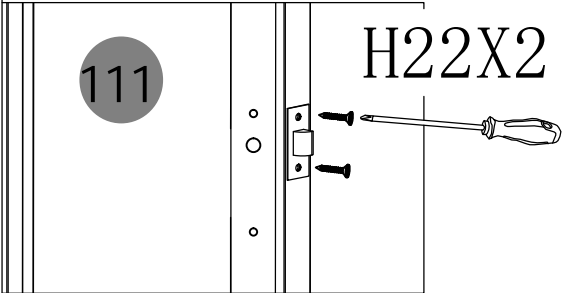
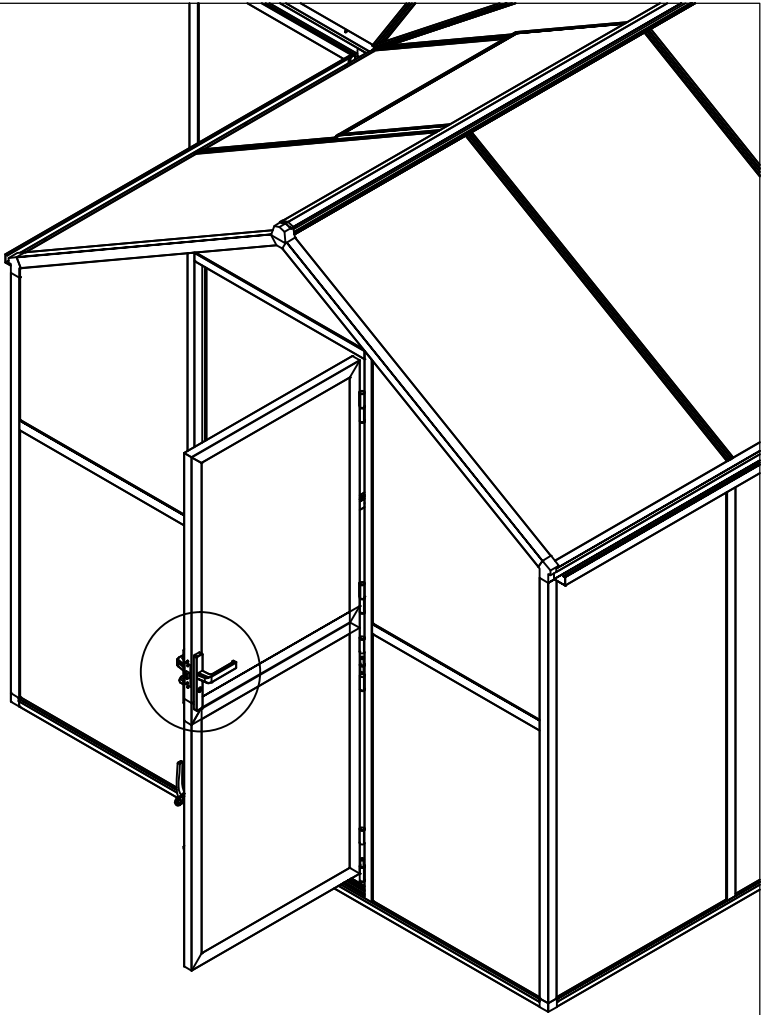
 5X15	H22	2pcs
	H14	1pc



	Z12	13pcs
 M6x12	H10	22pcs

