

1	1/2		
2	1/2		
3	1/2		
4	1/2		
5	1/2		
6	1/2		
7	1/2		
8	2/2		
9	2/2		
10	2/2		
11	2/2		
12	2/2		
13	2/2		
14	2/2		



Proszę montować mebel na kartonie!
Bitte das Möbel auf der Verpackung montieren!
Please assemble the piece of furniture on the cardboard!

Zložte prosím kus nábytku na kartón!
Sestavte prosím kus nábytku na kartón!
Si prega di assemblare i mobili sul cartone!
Veuillez assembler le meuble sur le carton!
Kérem kartonra szerelje össze a bútörököt!
Vä rugãm sã asamblați mobila pe carton!

- (PL) INSTRUKCJA MONTAŻOWA
- (DE) MONTAGENLEITUNG
- (GB) ASSEMBLY INSTRUCTIONS
- (SK) NÁVOD NA MONTÁŽ
- (CZ) MONTÁŽNÍ NÁVOD
- (IT) ISTRUZIONI DI ASSEMBLAGGIO
- (FR) NOTICE DE MONTAGE
- (HU) TELEPÍTÉSI ÚTMUTATÓ
- (RO) INSTRUCȚIUNI DE INSTALARE

PL Szanowny Kliencie. Gdyby brakowało jakiejś części lub byłaby uszkodzona, to proszę oznaczyć część krzyżykiem na instrukcji montażowej i przesłać instrukcję razem z reklamacją.

DE Sehr geehrter Kunde. Sollte ein Teil fehlen oder beschädigt sein, kreuzen Sie bitte dieses deutlich auf der Montageanleitung an und schicken Sie zu uns ab.

GB Dear customer. Should there be any place missing or damaged, kindly mark this place clearly on the attached assembly instructions and return it to us.

SK Vážení zákazník, keby chýbali nejaká časť, alebo by bola poškodená, označte ju prosím krížikom na montážnom návode a zašlite návod spolu s reklamáciou.

CZ Vážení zákazník, kdyby chýběla nějaká část nebo byla poškozená, označte ji prosím křížkem na montážním návodu a zašlete návod spolu s reklamací.

IT Gentile cliente. In caso di parti mancanti o danneggiate, contrassegnare la parte con una croce sulle istruzioni di montaggio e inviare le istruzioni insieme al reclamo.

FR Cher client, si une pièce est manquante ou endommagée, veuillez marquer la pièce d'une croix sur la notice de montage et envoyer la avec votre réclamation.

HU Kedves ügyfél. Ha valamelyik alkatrész hiányzik vagy sérült, kérjük, jelölje be az alkatrészt kereszttel az összeszerelési útmutatóban, és küldje el az útmutatót a reklamációval együtt.

RO Draga client. Dacă vreo piesă lipsește sau este deteriorată, marcați piesa cu o cruce pe instrucțiunile de asamblare și trimiteți instrucțiunile împreună cu reclamația.

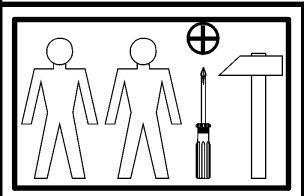
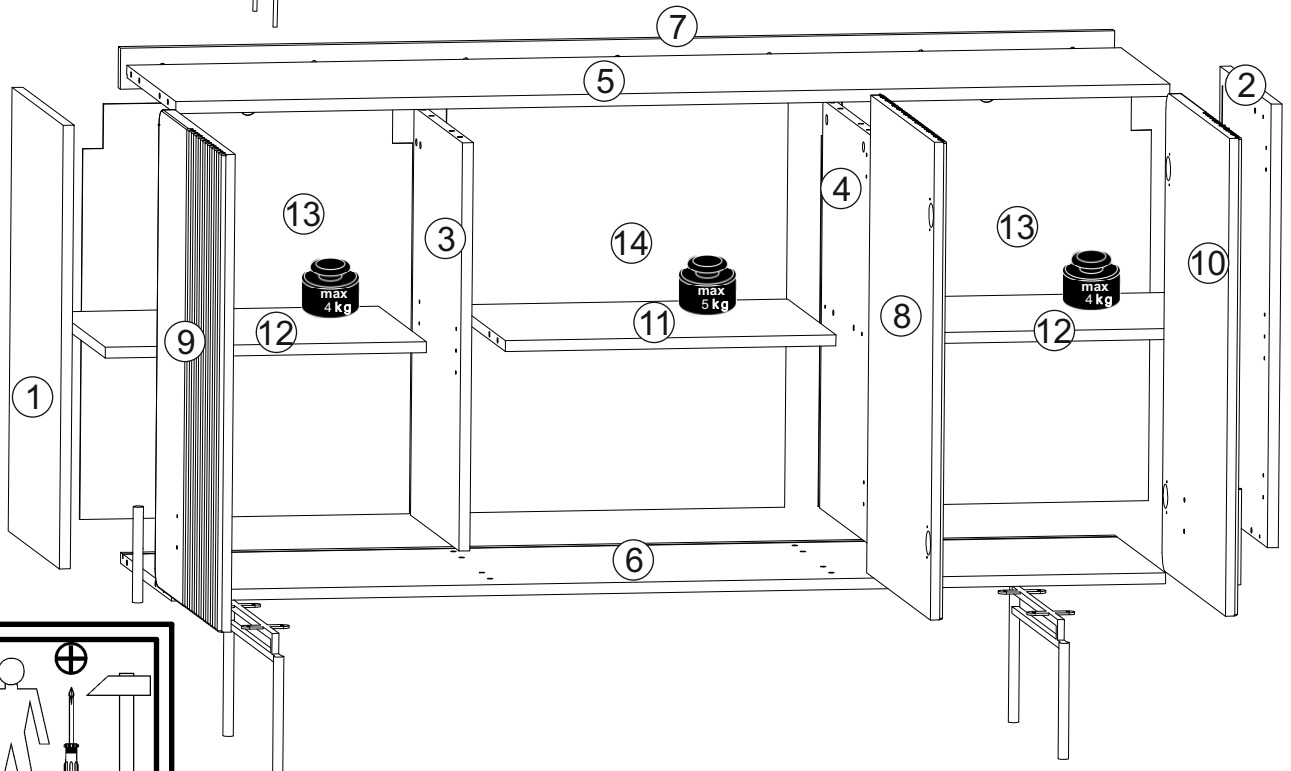
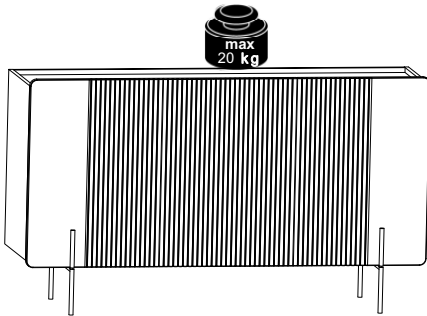

4x a204	6x b112	12x φ3,5x15 mm p51	8x 20x13x3,51 n108	2x a205	1x z1	4x M4x25 mm j53	4x l1
2x n165L	2x n165P	8x φ4x30 mm p21	8x φ5x17 mm d1	20x φ5 s4	8x φ2,9x16 mm p55	12x φ16 s2	2x n26\1
16x φ15x12 mm #16 r1	16x r42	20x φ8x30 mm f1	11x φ7x50 mm e1	12x φ3,5x16 mm p38	30x l2	4x φ6x60 mm p75	2x φ5x60 mm p17
6x φ10x50 mm f35							

1 opcja, option, možnost 1

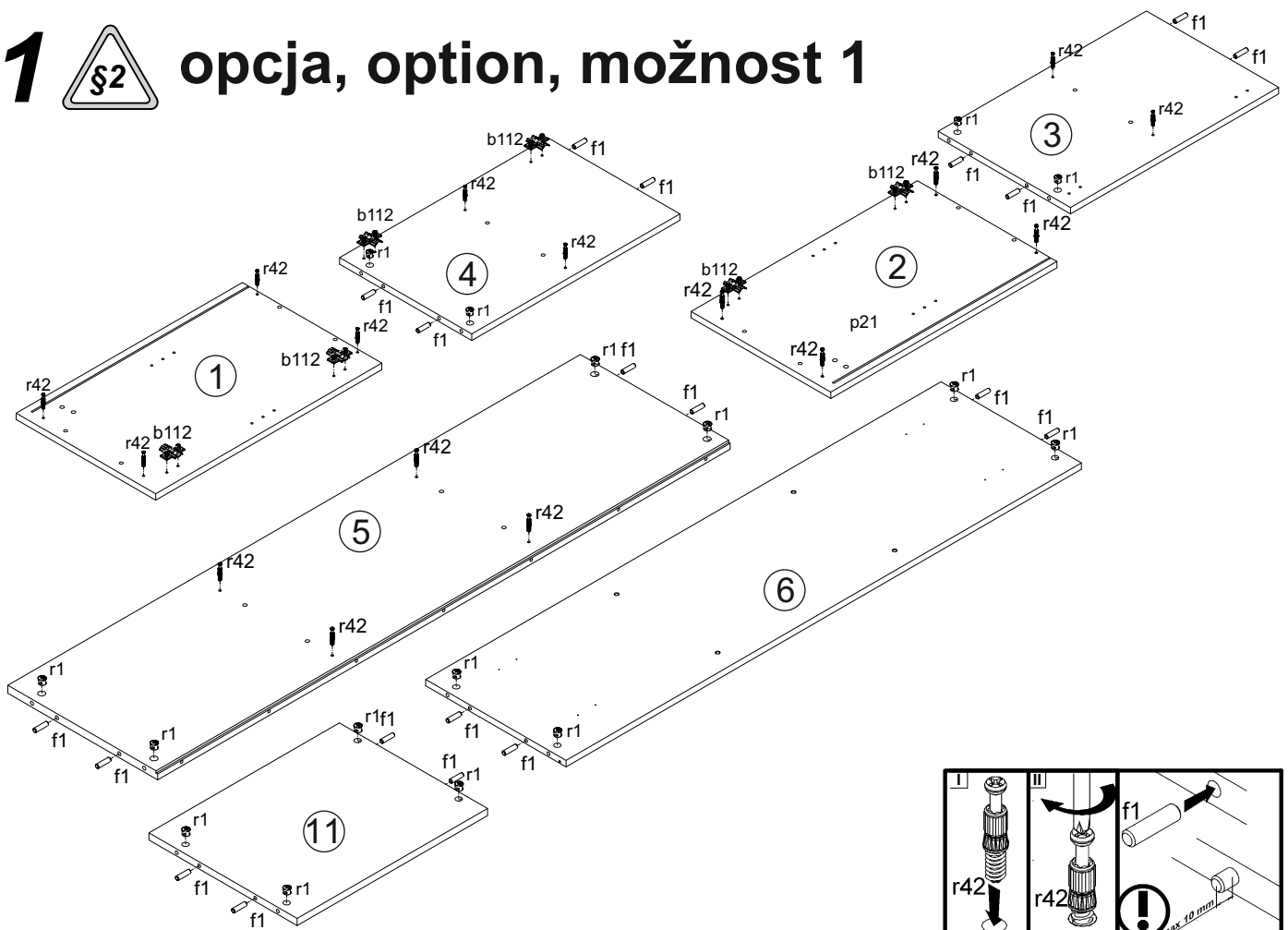

2

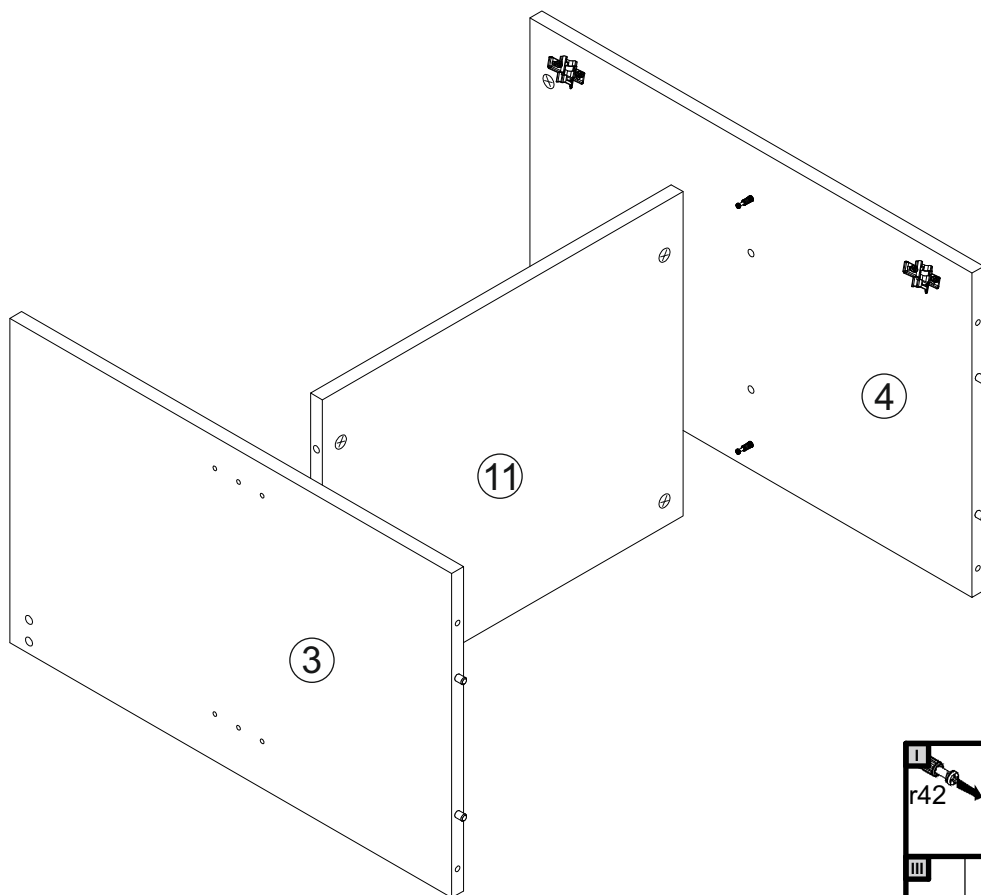

3

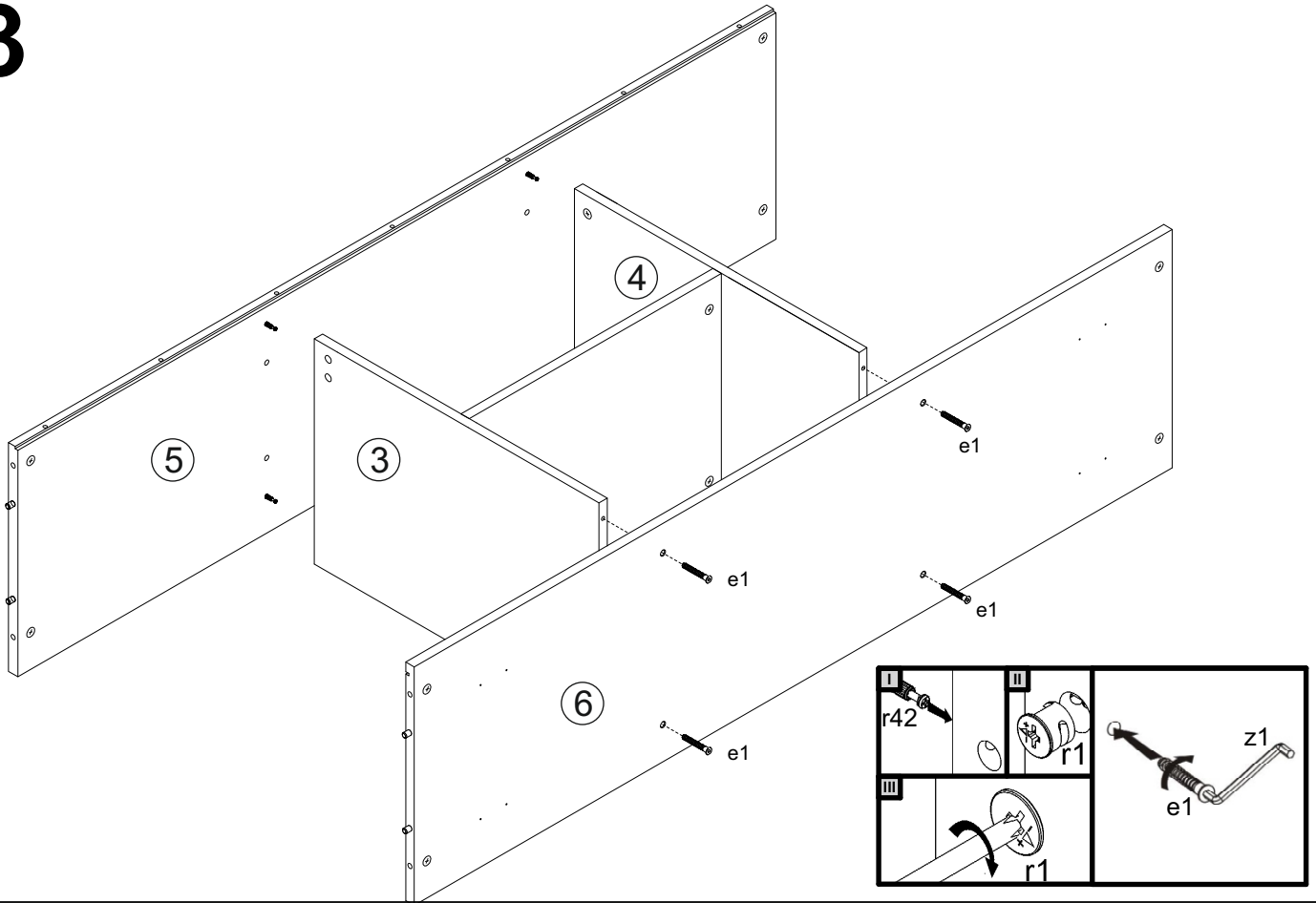

4

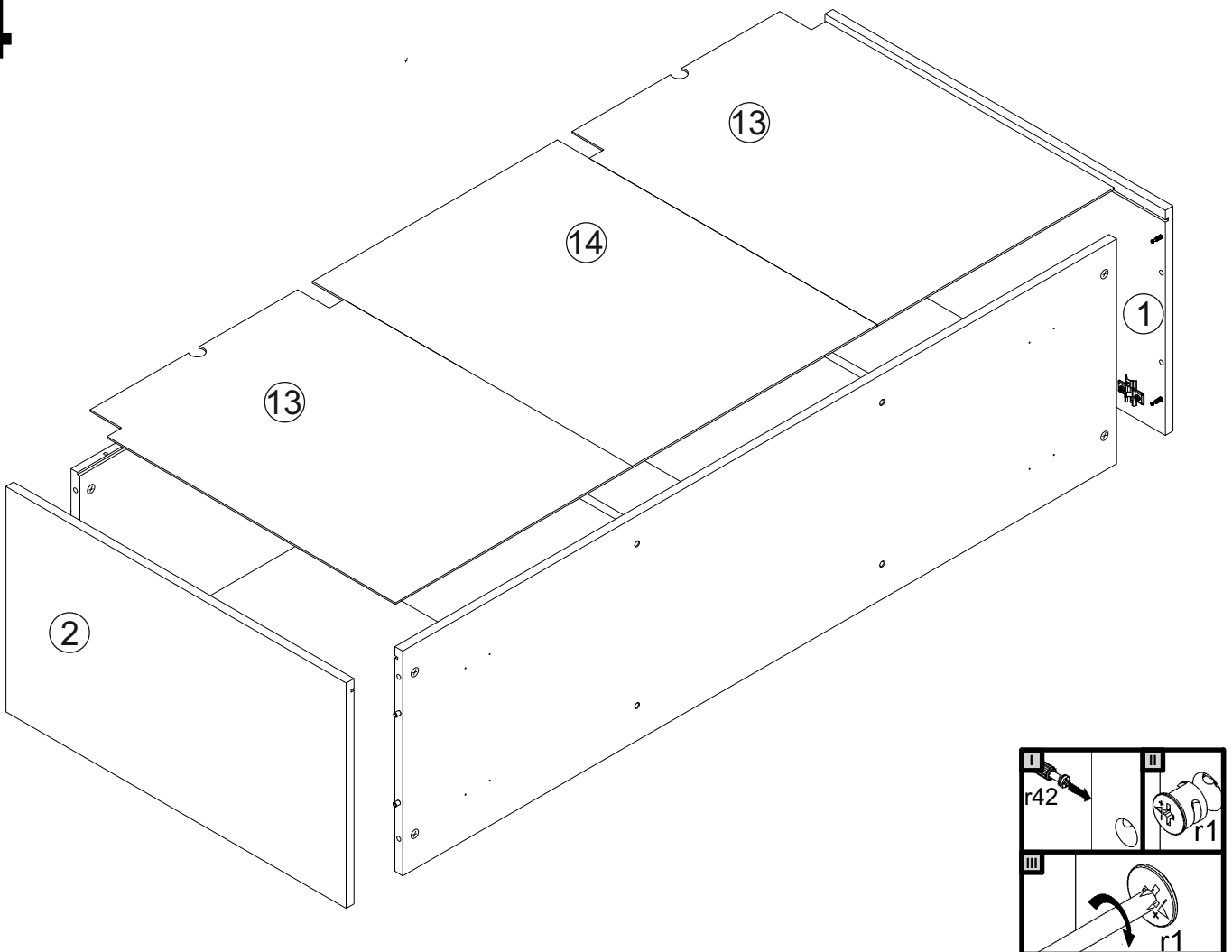

5

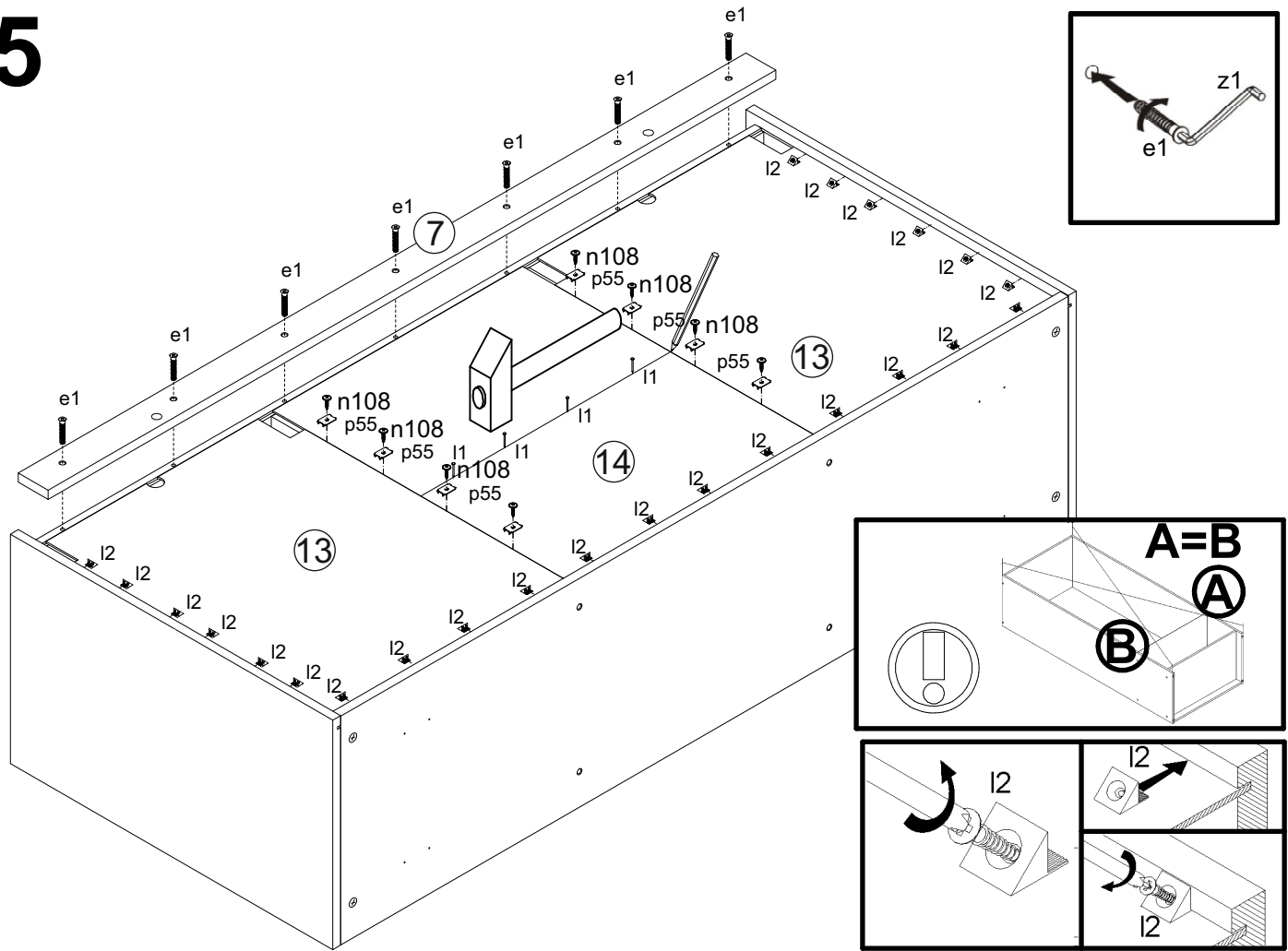

6

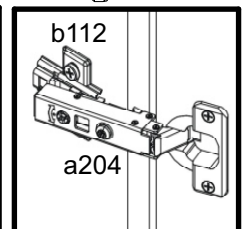
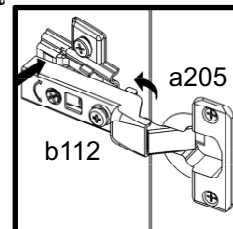
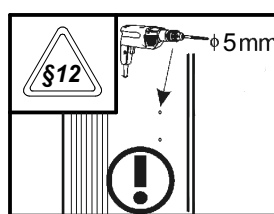
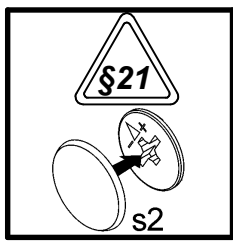
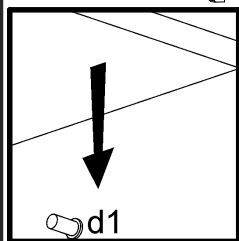
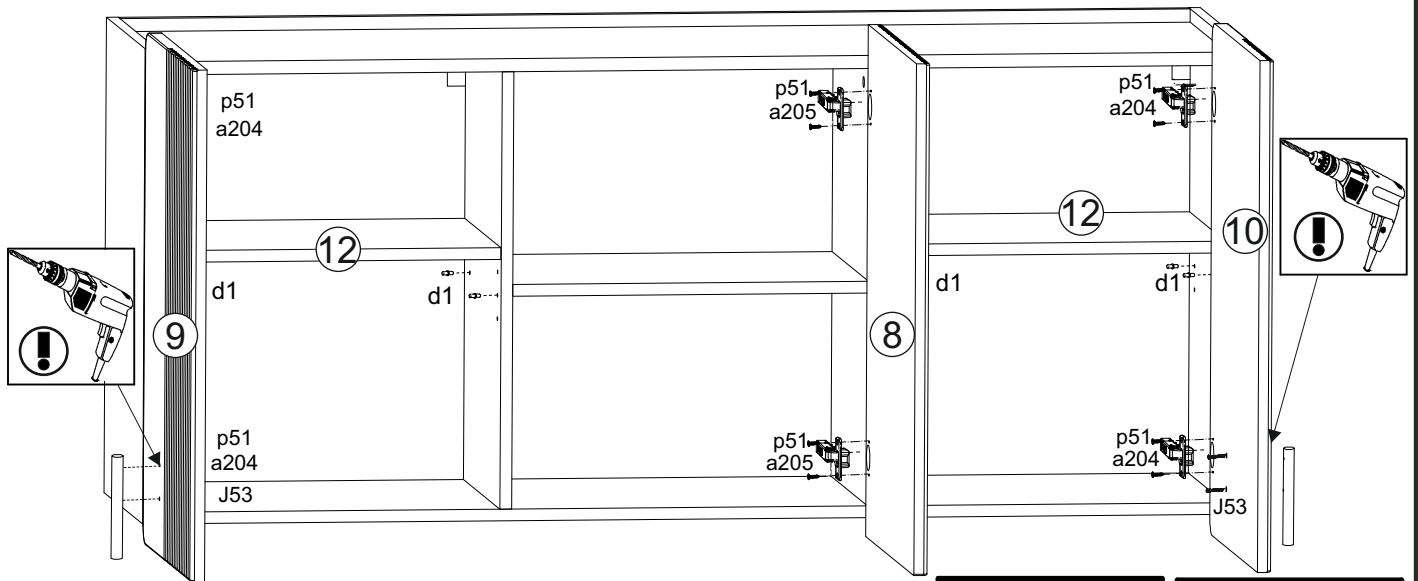

7

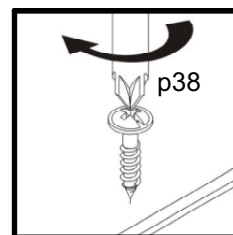
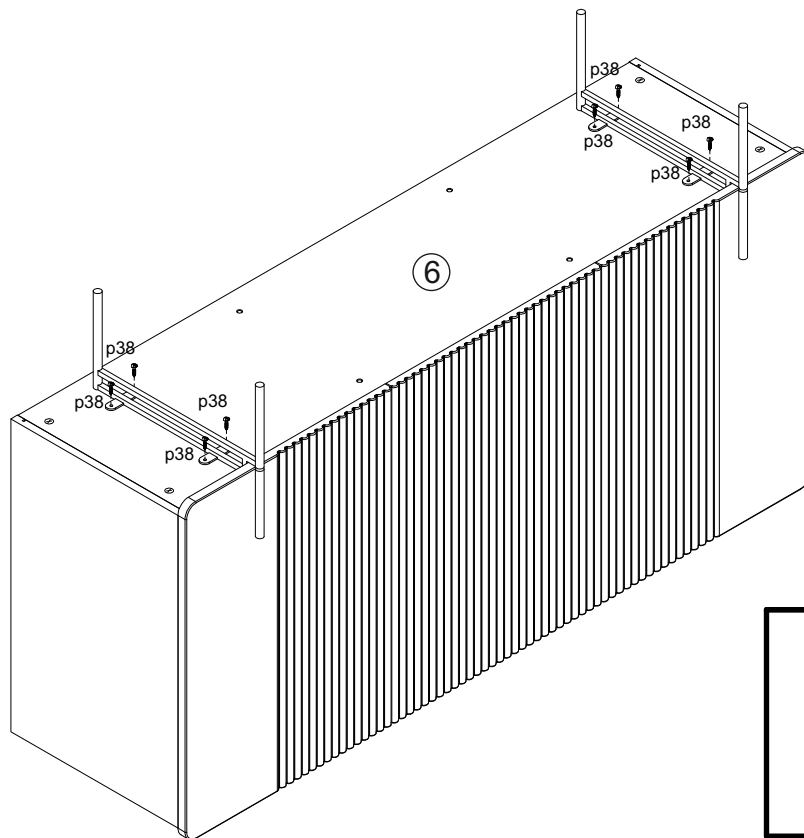

1 opcja, option, možnost 2

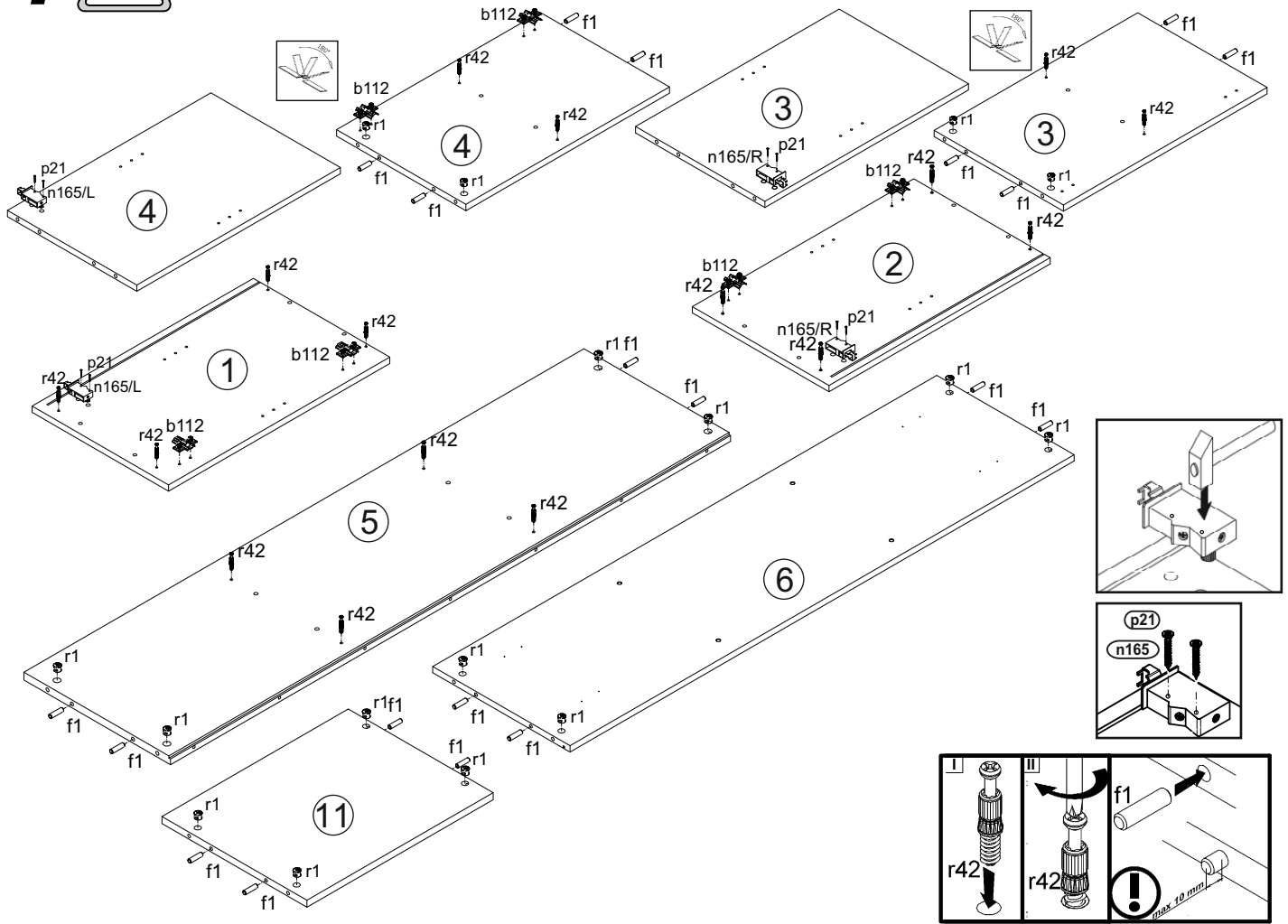

2

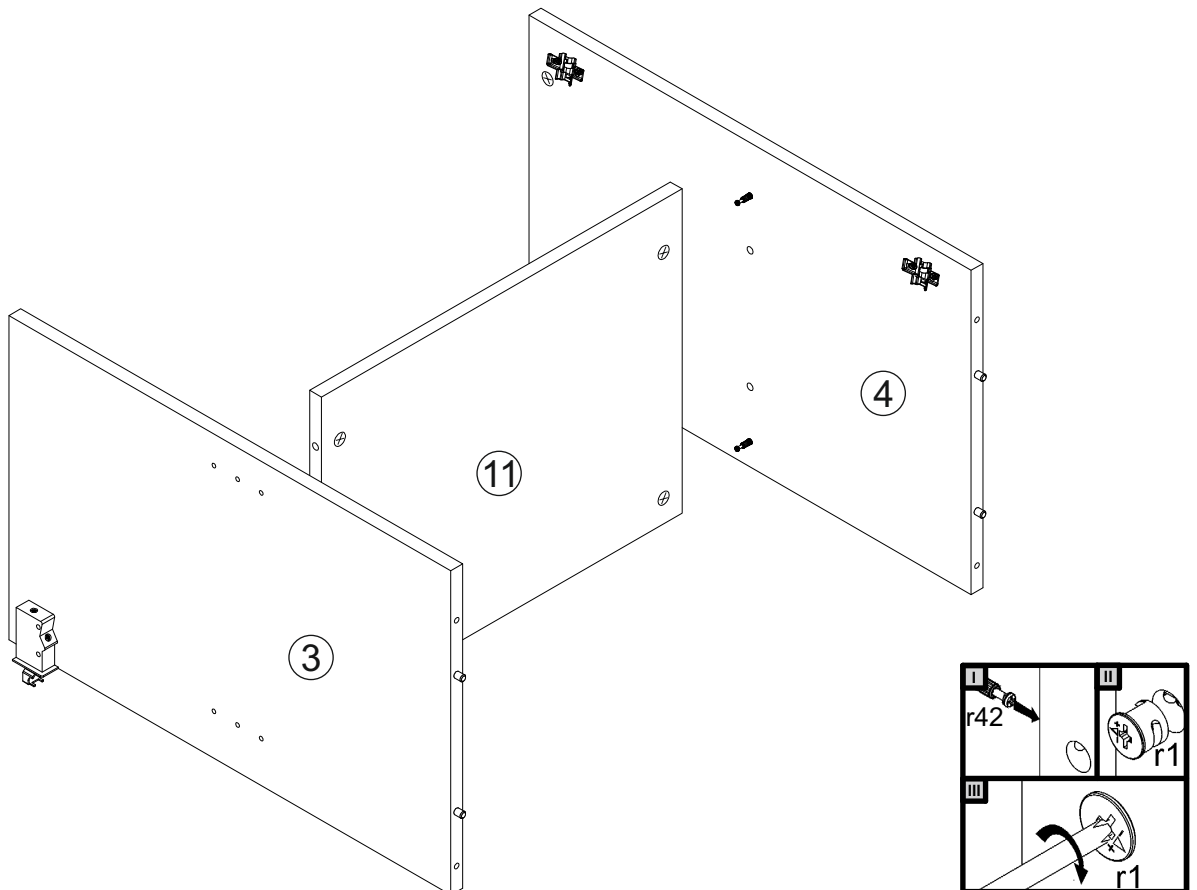

3

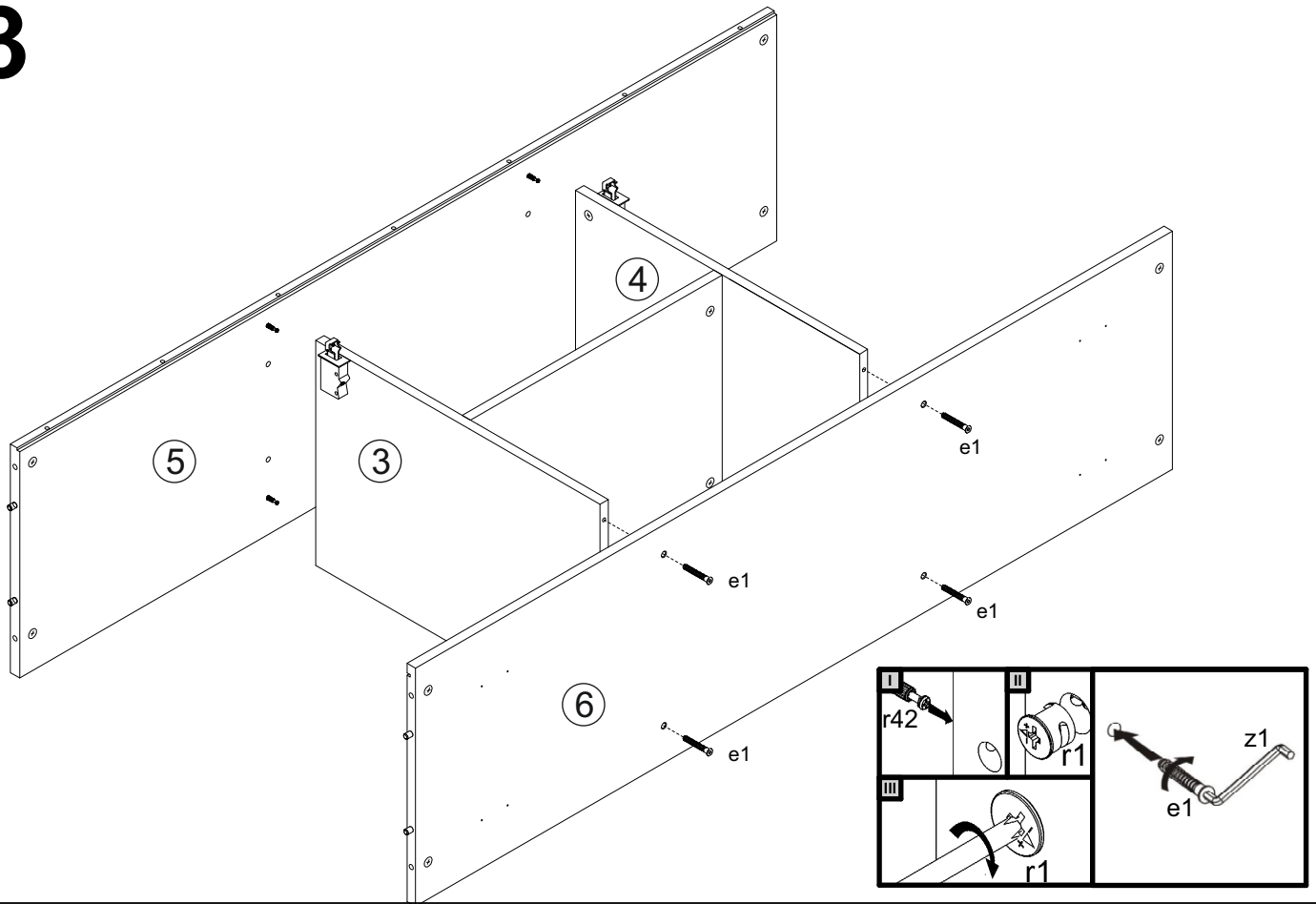

4

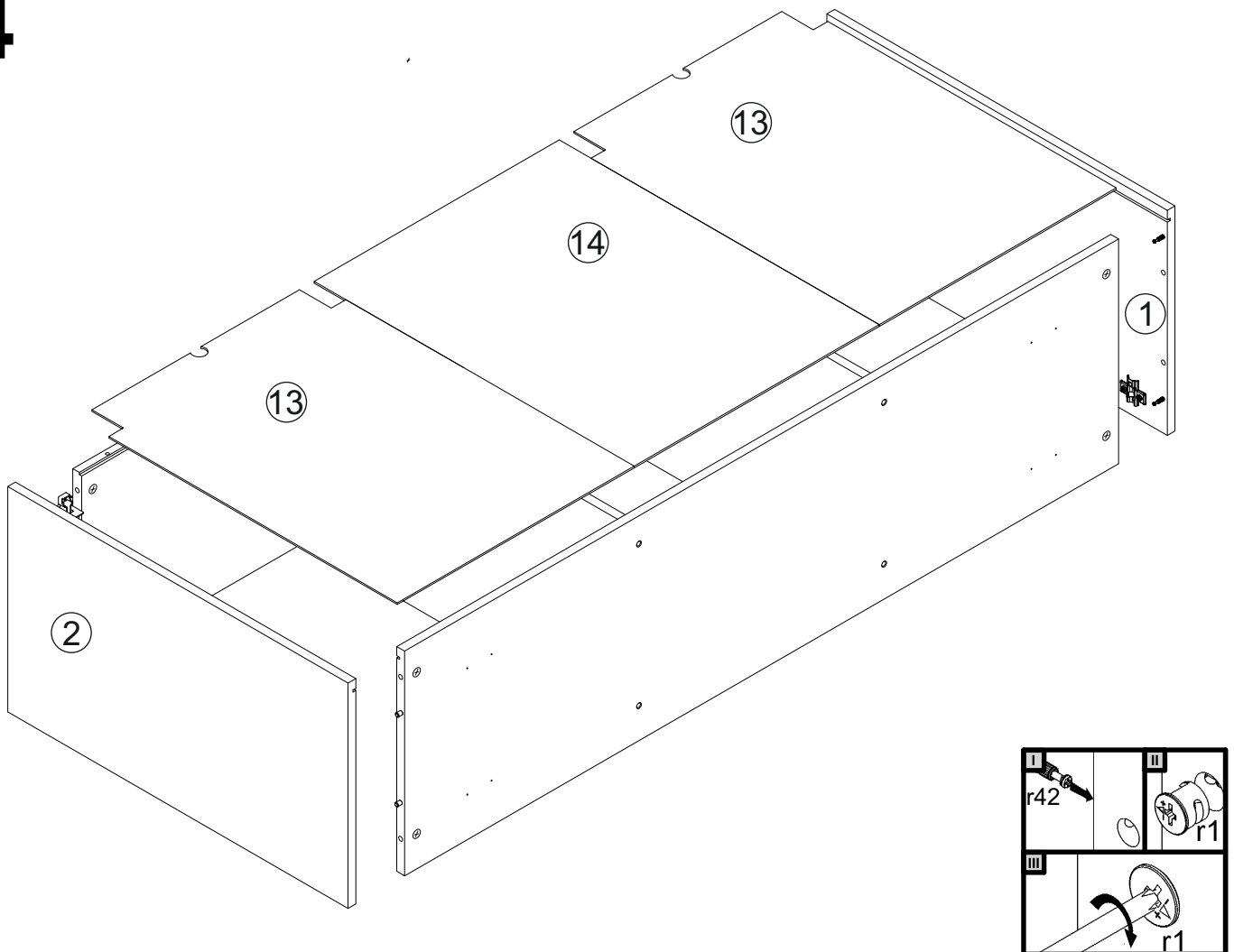

5

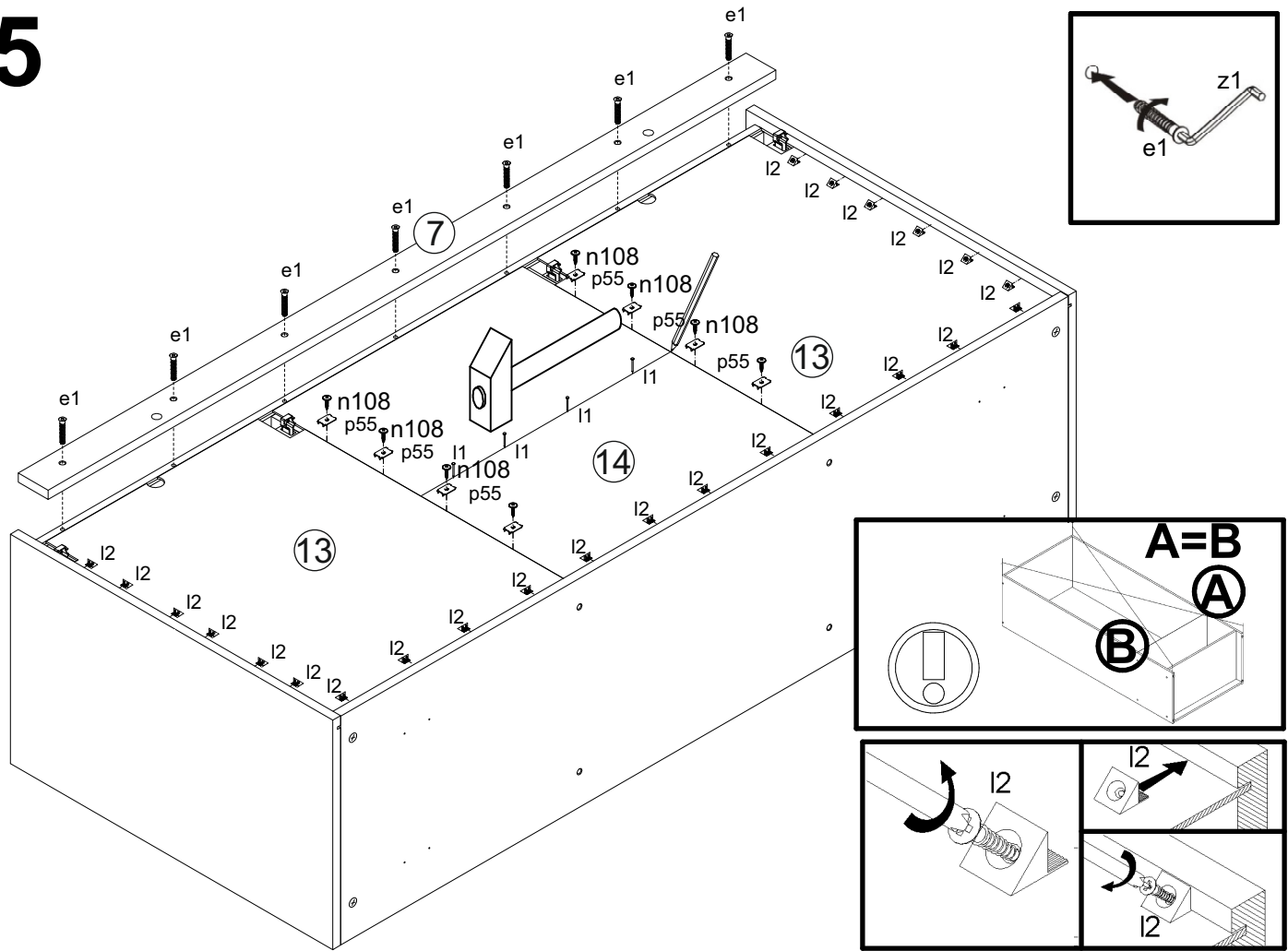

6

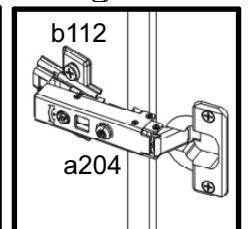
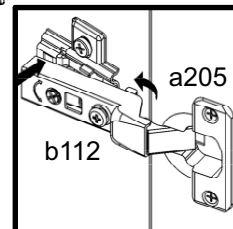
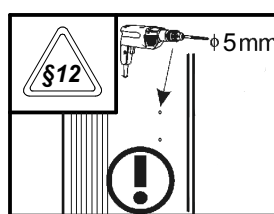
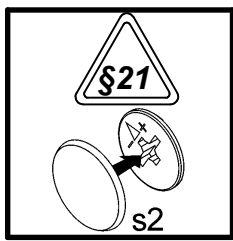
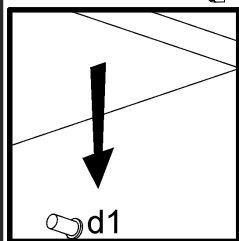
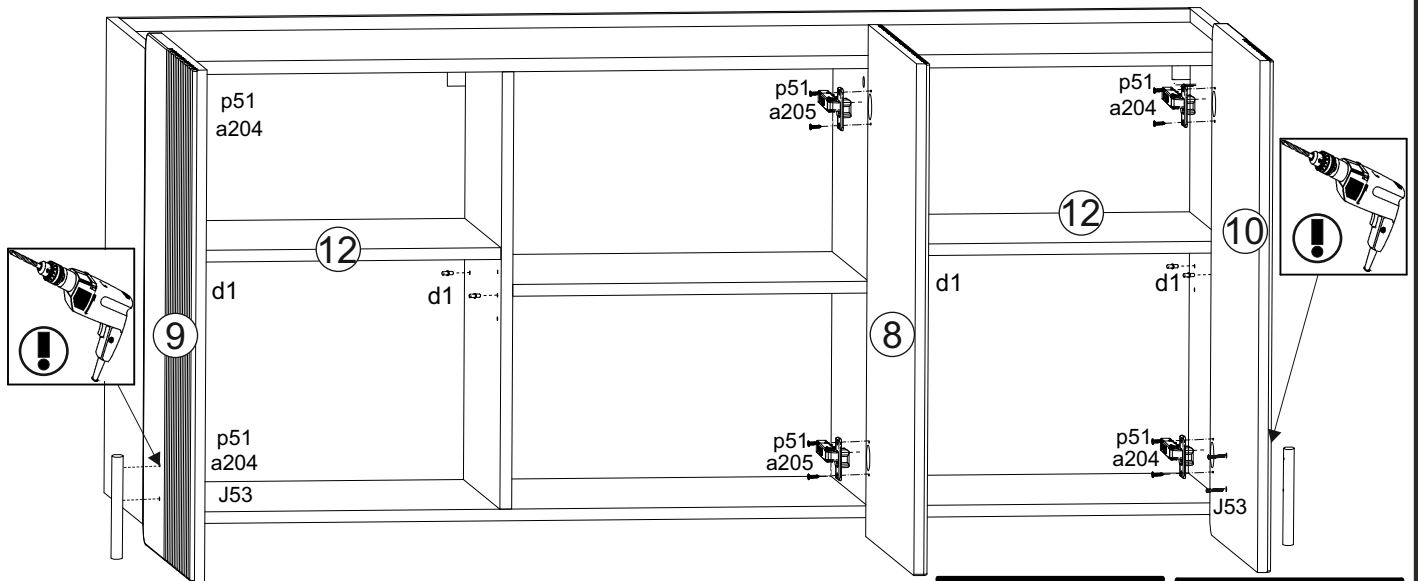

7

