

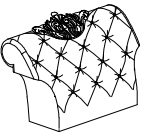

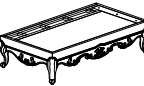
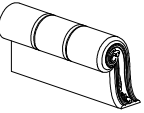
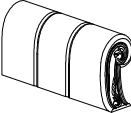
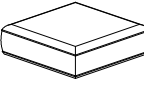

# ASSEMBLY INSTRUCTION

## LOVESEAT W/2 PILLOWS

Thank you for purchasing this quality product. Be sure to check all packing material carefully for small parts which may have come loose inside the carton during shipment. Separate, identify and count all parts and metal hardware. Compare with parts list to be sure all parts are present. If any part(s) are missing or damaged, please contact your local furniture dealer. For efficient and speedy service, please indicate the model number and code letter of part(s) needed.

\*\*\* Do not fully tighten screws until fully assembled \*\*\*

<b>PARTS LIST</b>		
A		Top frame  1
B		Base frame  1
C		Armrest (L)  1
D		Armrest (R)  1
E		Mattress  2

<b>HARDWARE LIST</b>			
1		Bolts 5/16"x 60mm	8
2		Spring washers Ø5/16"x 13mm	8
3		Flat washers Ø5/16"x 19mm	8
4		Allen key K4	1

Step 1

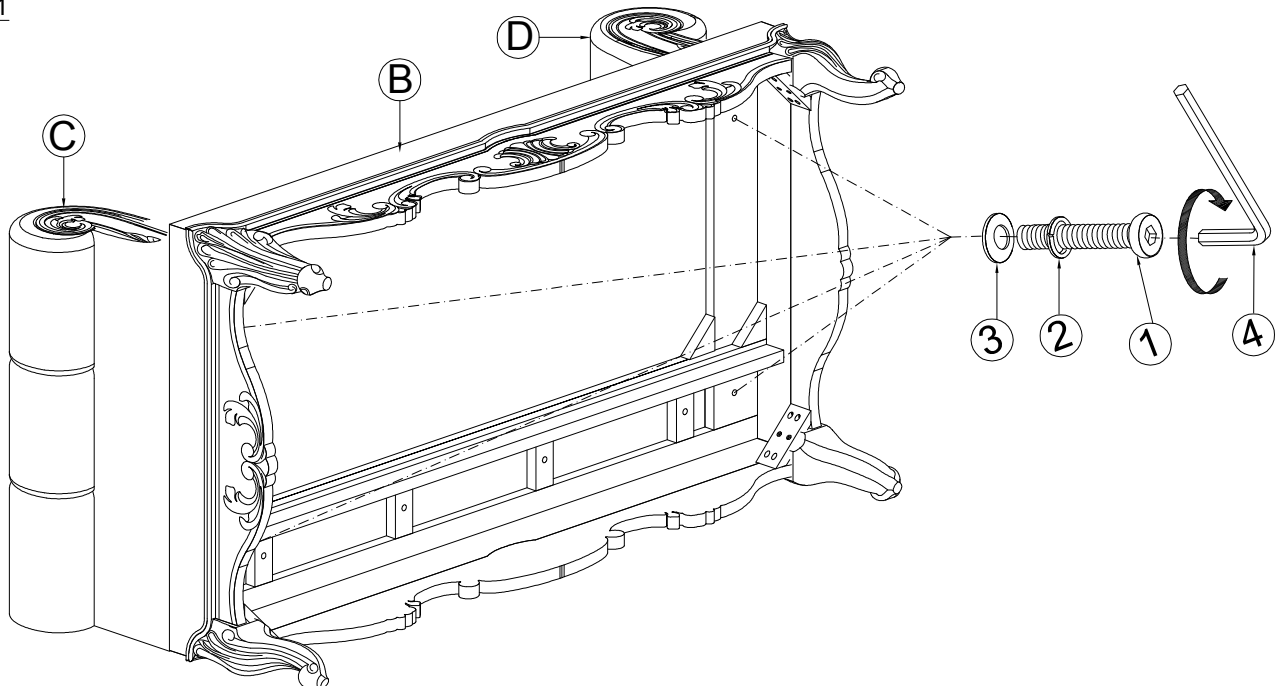

# ASSEMBLY INSTRUCTION

## LOVESEAT W/2 PILLOWS

Thank you for purchasing this quality product. Be sure to check all packing material carefully for small parts which may have come loose inside the carton during shipment. Separate, identify and count all parts and metal hardware. Compare with parts list to be sure all parts are present. If any part(s) are missing or damaged, please contact your local furniture dealer. For efficient and speedy service, please indicate the model number and code letter of part(s) needed.

\*\*\* Do not fully tighten screws until fully assembled \*\*\*

### Step 2

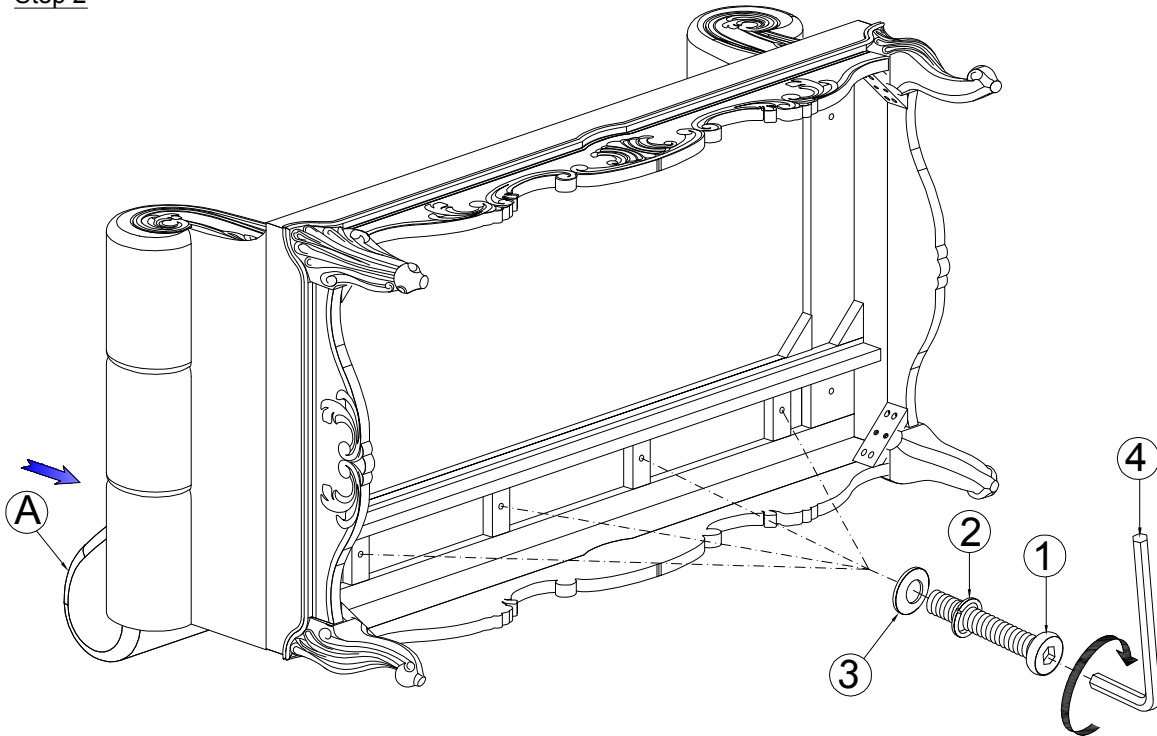

### Step 3

