

As this item contains many parts, please read the installation instruction carefully before installation and complete the installation with the cooperation of your partner. Please use tools properly and carefully. If you have any questions about the product and installation, please contact us.

Our professional after-sales team will serve you online all day.

Before You Start

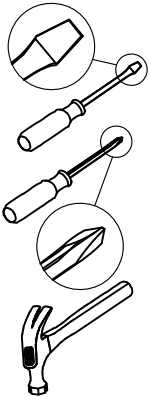

- ✓ Read through each step carefully and follow the proper order
- ✓ Separate and count all your parts and hardware
- ✓ Give yourself enough room for the assembly process
- ✓ Have the following tools: Flat Head Screwdriver, #2 Phillips Head Screwdriver and Hammer
- ✓ Caution: If using a power drill or power screwdriver for screwing, please be aware of to slow down and stop when screw is tight. Failure to do so may result in stripping the screw.

Helpful Hints

PEOPLE NEEDED FOR ASSEMBLY: 1-2

- Open your item in the area you plan to keep it to avoid excessive heavy lifting.
- Identify, sort and count the parts before attempting assembly.
- Compression dowels are lightly tapped in with a hammer.
- Slides are labeled with an **R** (right) and **L** (left) for proper placement.
- Make sure to always face the point on the top of the Cam Lock towards the outer edge.
- Use all the nails provided for the back panel and spread them out equally.
- Back panel must be used to make sure your unit is sturdy.
- Do NOT use harsh chemicals or abrasive cleaners on this item.
- Never push, pull, or drag your furniture.



Board Identification

Not actual size

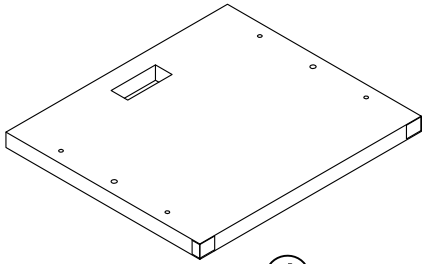

(A)

TOP

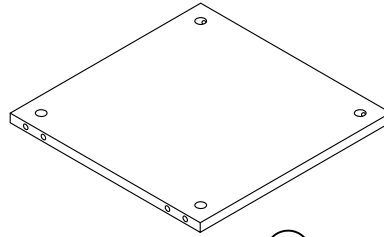

(B)

FIXED SHELF

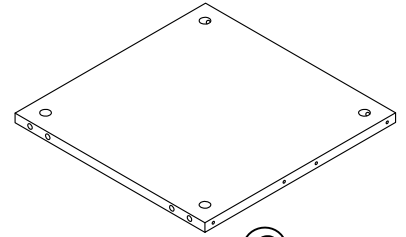

(C)

BOTTOM

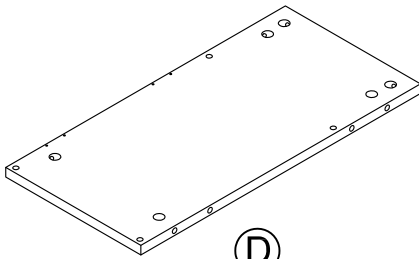

(D)

LEFT SIDE PANEL

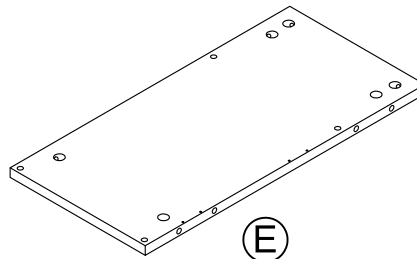

(E)

RIGHT SIDE PANEL

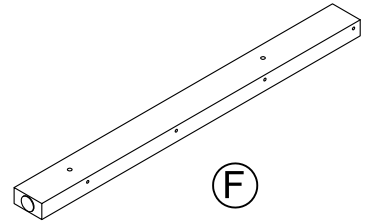

(F)

LEG

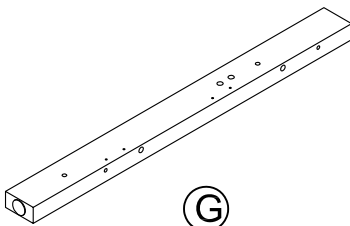

(G)

LEG

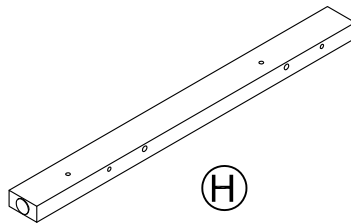

(H)

LEG

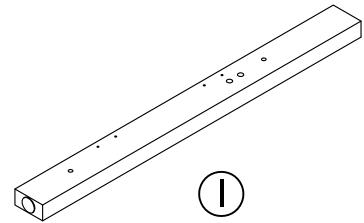

(I)

LEG

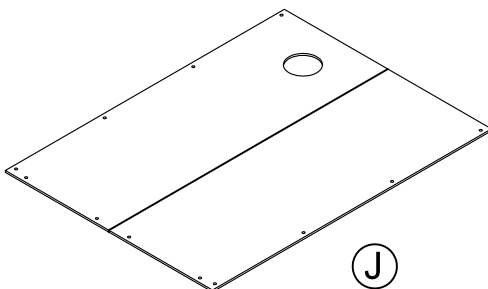

(J)

BACK PANEL

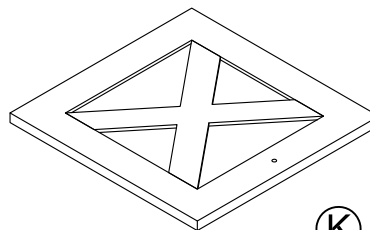

(K)

DOOR

Board Identification

Not actual size

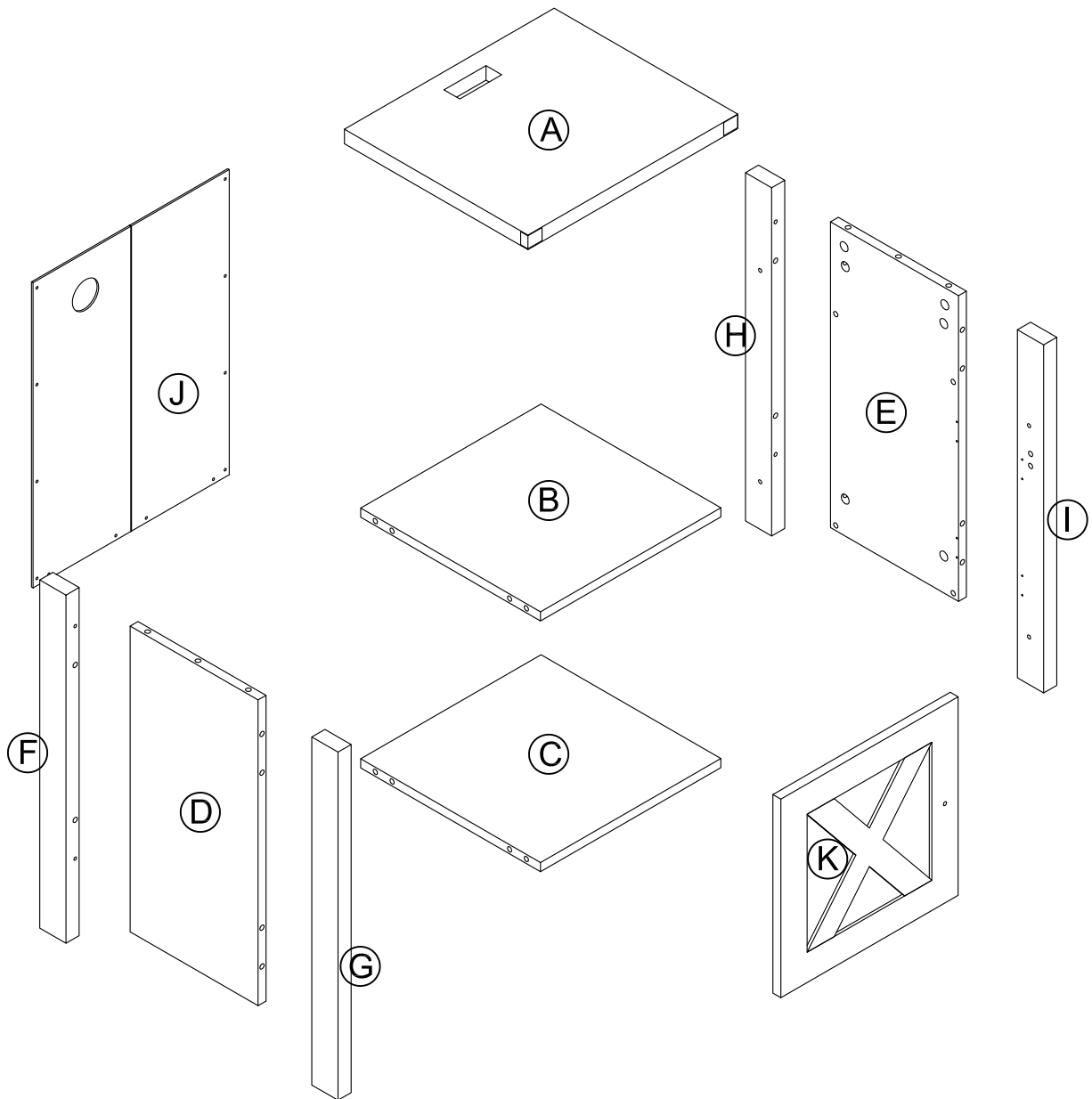

Part List

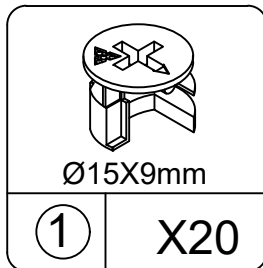

CAM LOCK
spare: 2

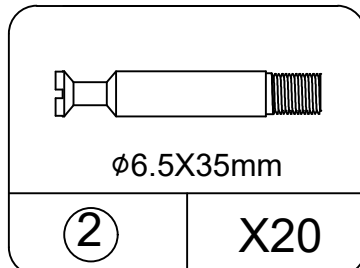

CAM BOLT
spare: 2

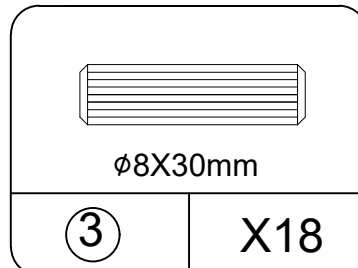

WOOD DOWEL
spare: 1

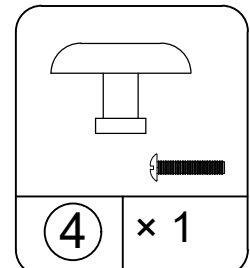

HANDLE

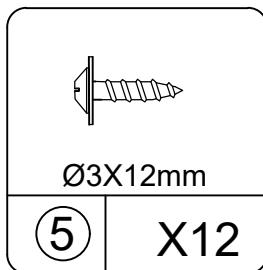

SCREW
spare: 1

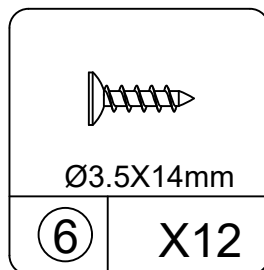

SCREW
spare: 1

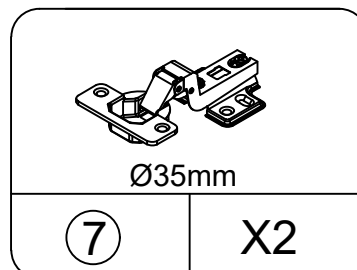

HINGE

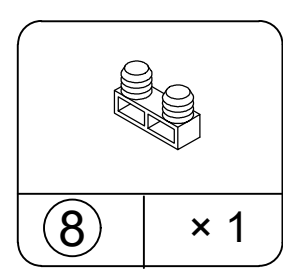

PLASTIC HOLDER

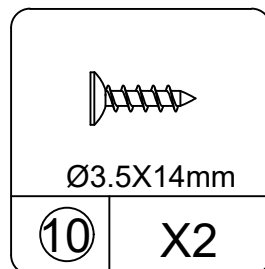
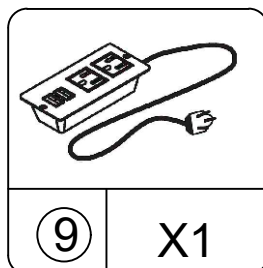

SCREW
spare: 1

Cam Lock Fastening System

This Cam Lock Fastening System will be used throughout the assembly process.

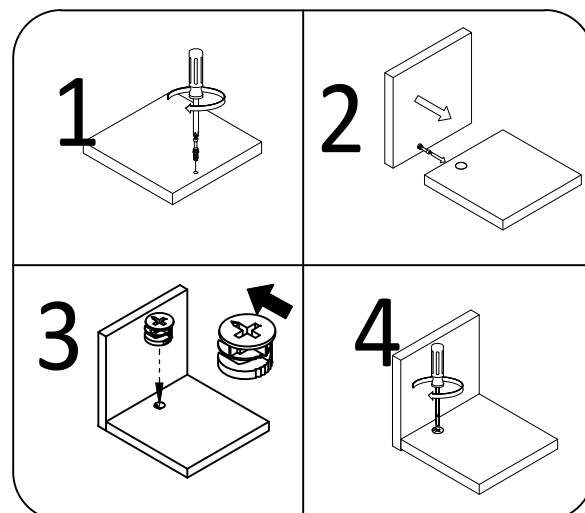

STEP 1

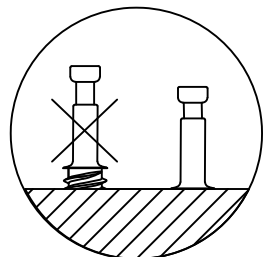
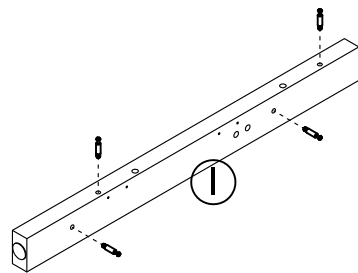
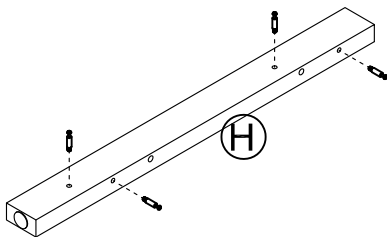
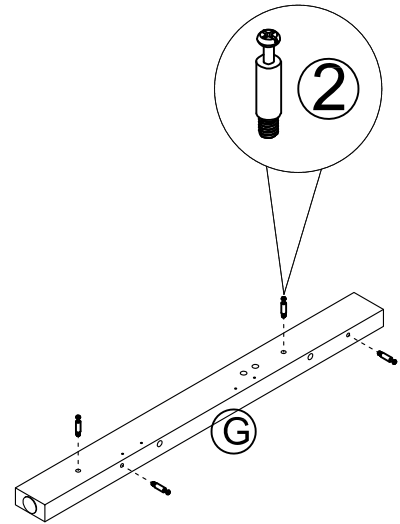
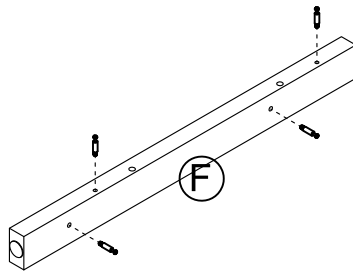
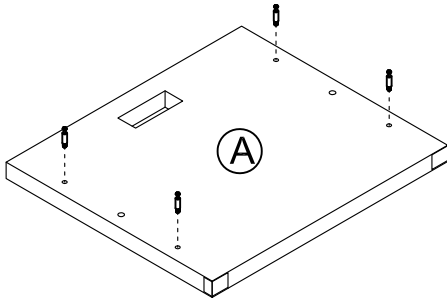
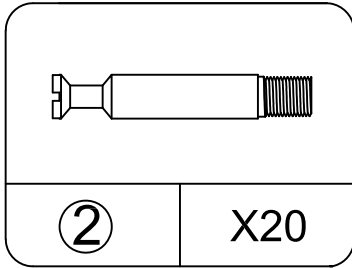
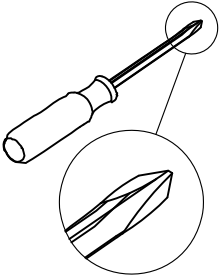

STEP 2

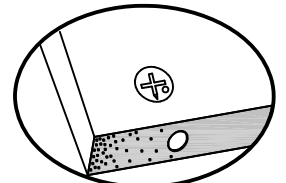
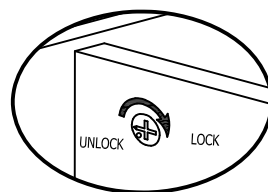
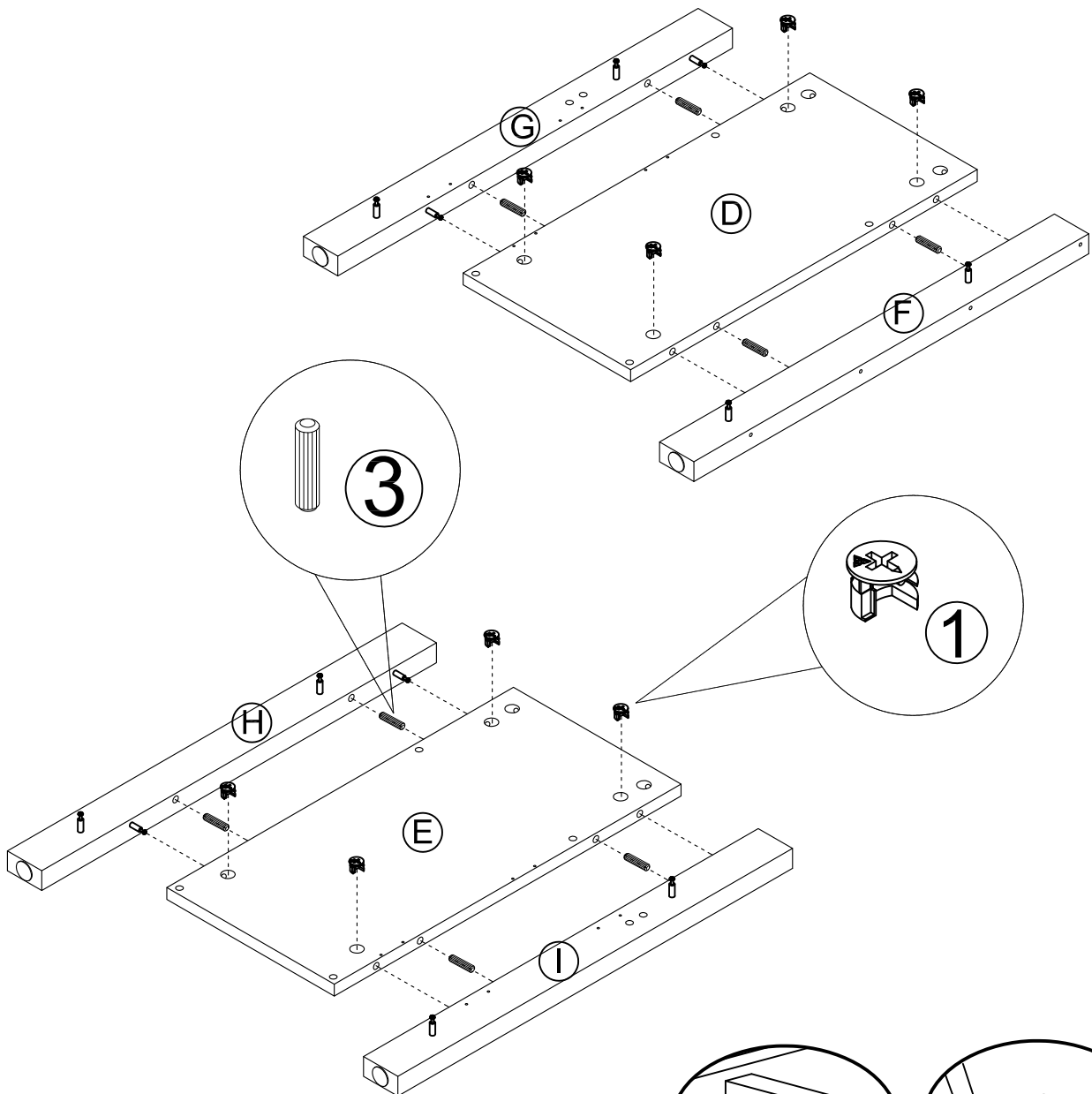
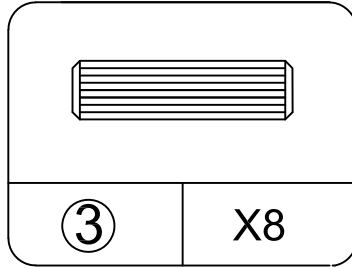
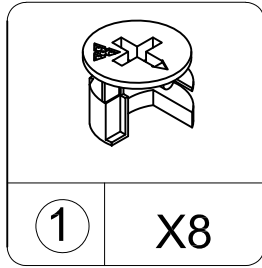
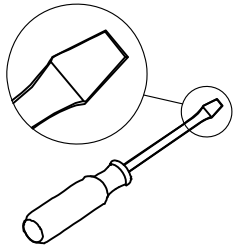

Proper orientation of CAM LOCK

STEP 3

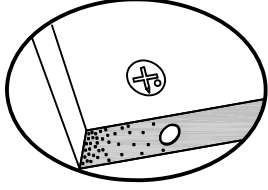
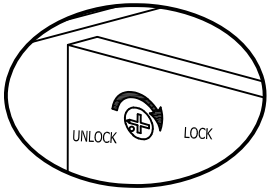
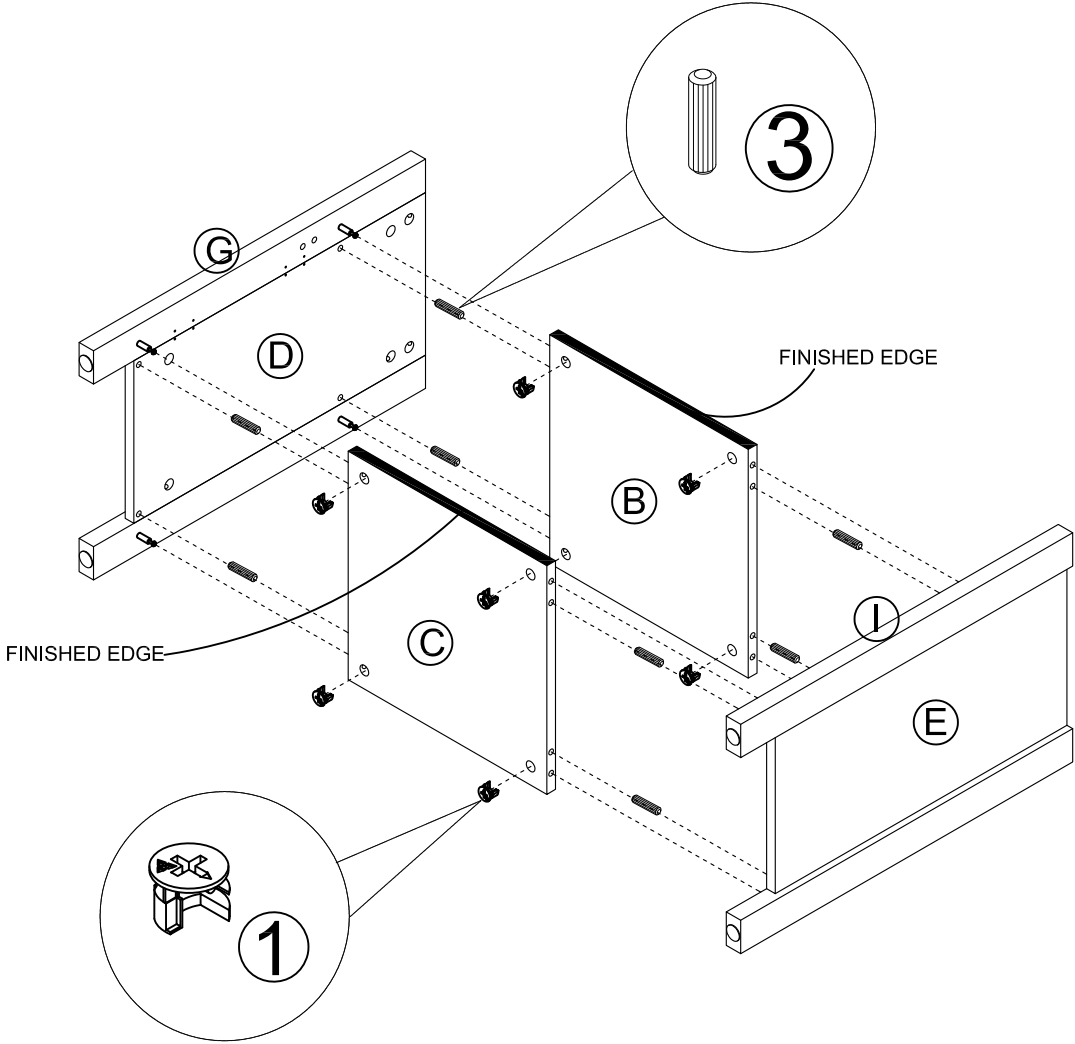
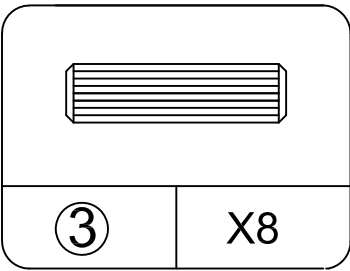
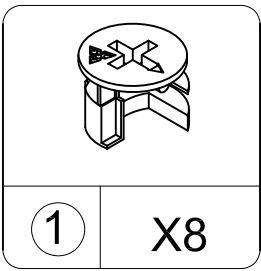
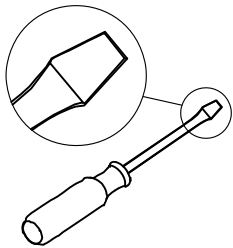

Proper orientation of CAM LOCK

STEP 4

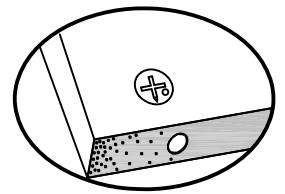
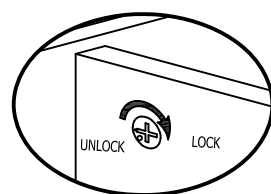
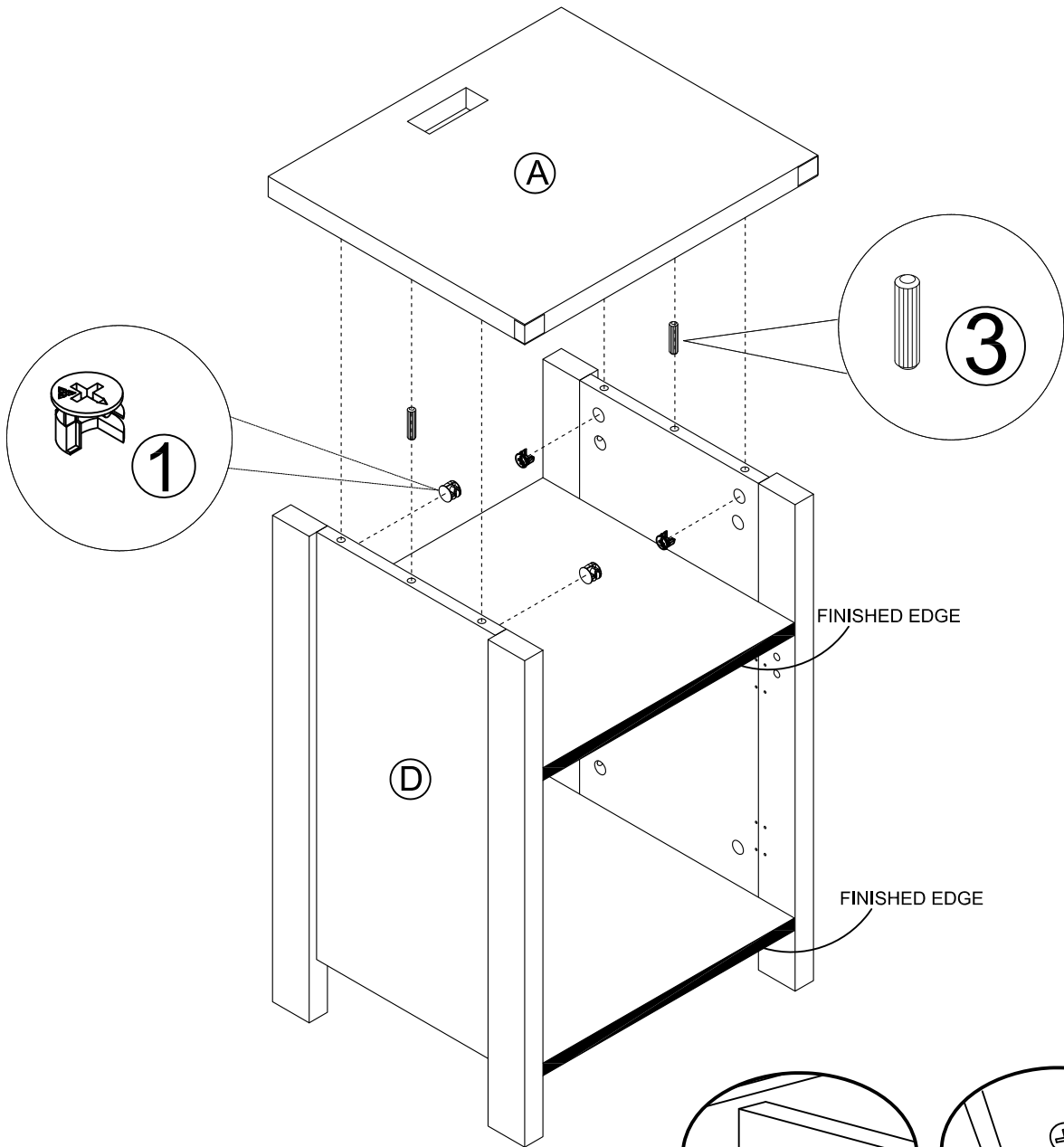
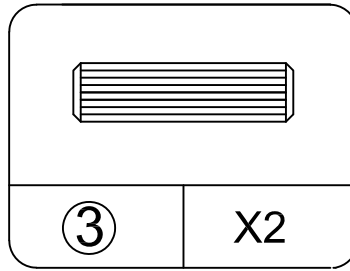
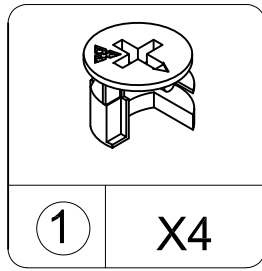
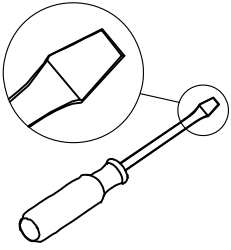

Proper orientation of CAM LOCK

STEP5

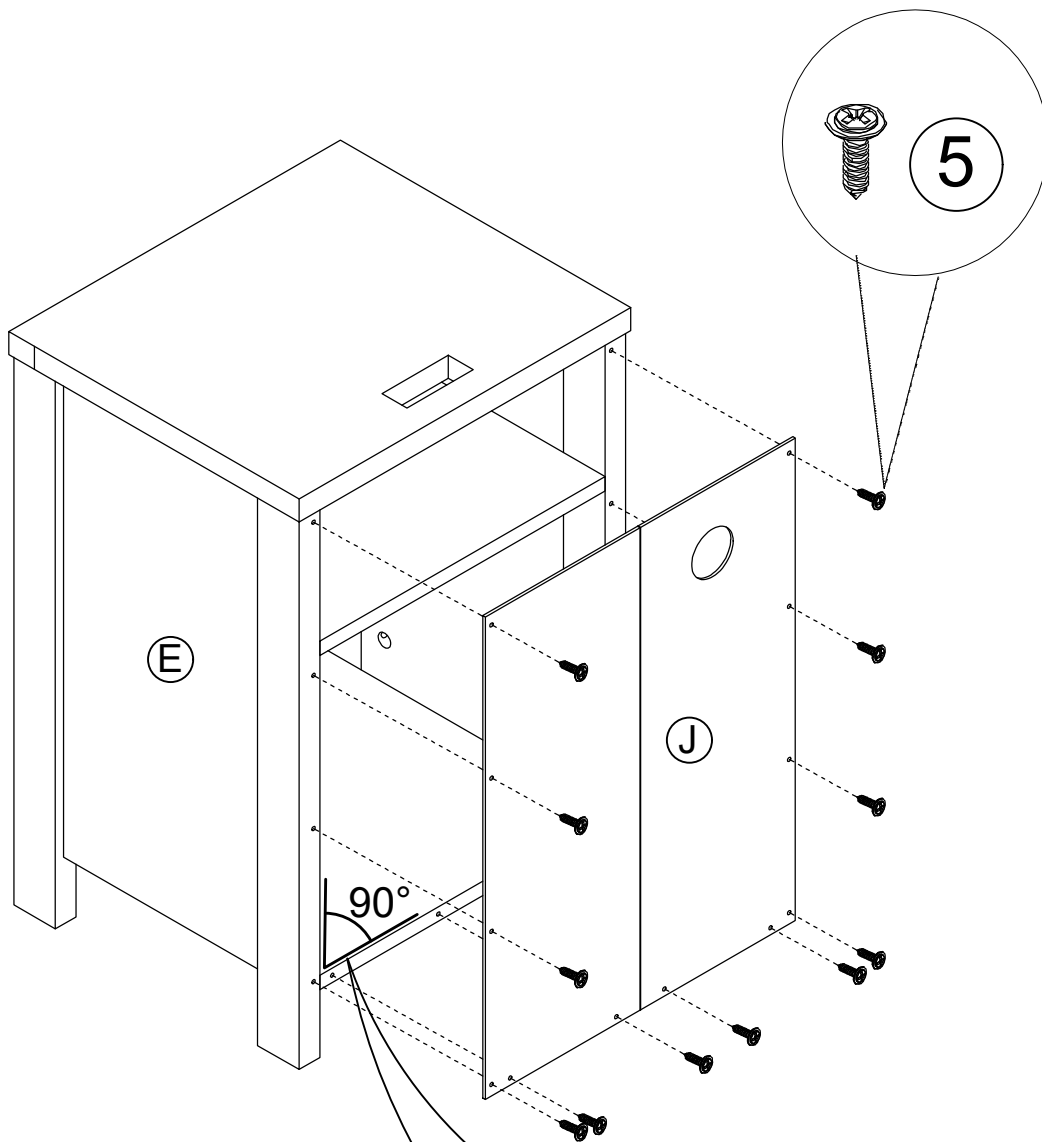
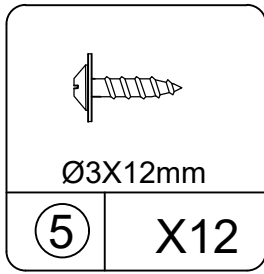
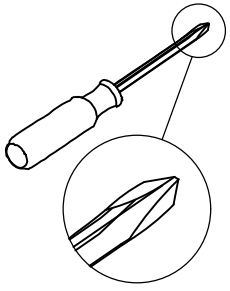

Before attaching the back panel, be sure that the unit is at 90°.

Antes de atar el panel trasero, asegúrese de que la unidad está a 90°.

STEP6

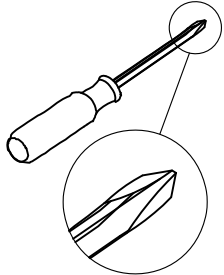

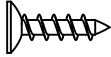
 Ø3.5X14mm	
10	X2

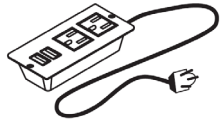
	
9	× 1

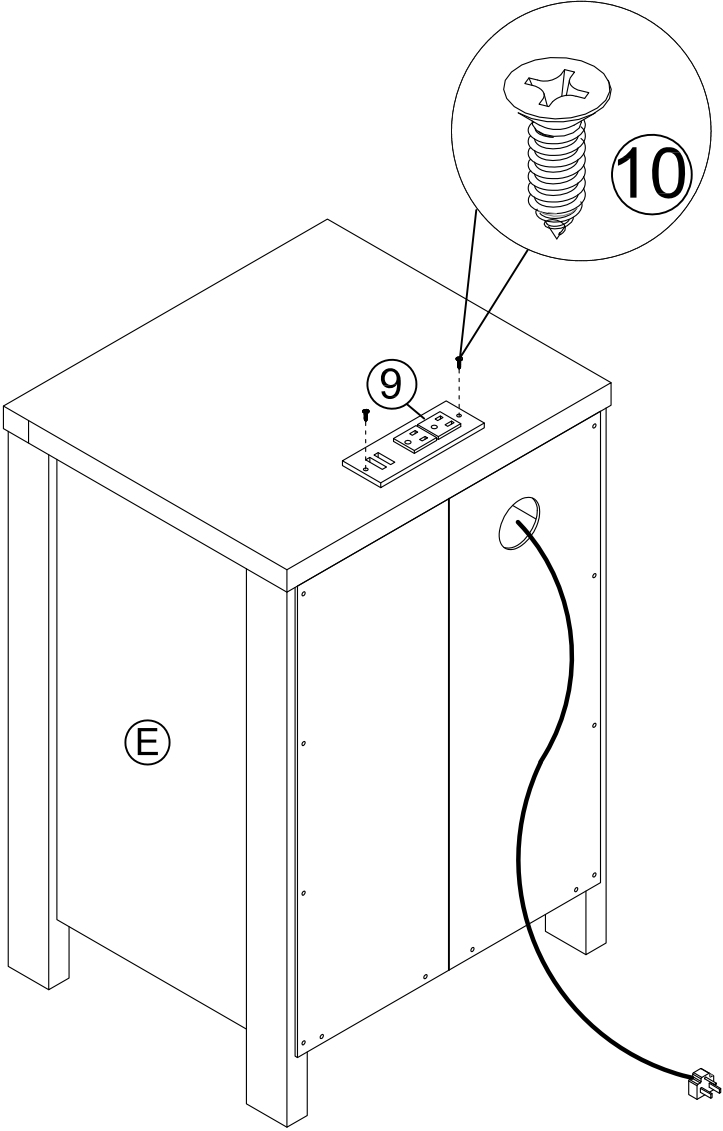

STEP 7

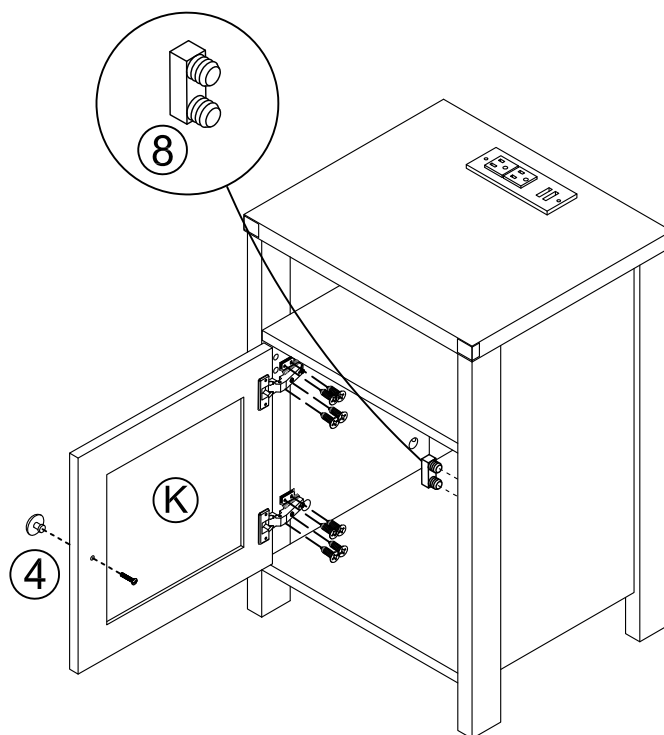
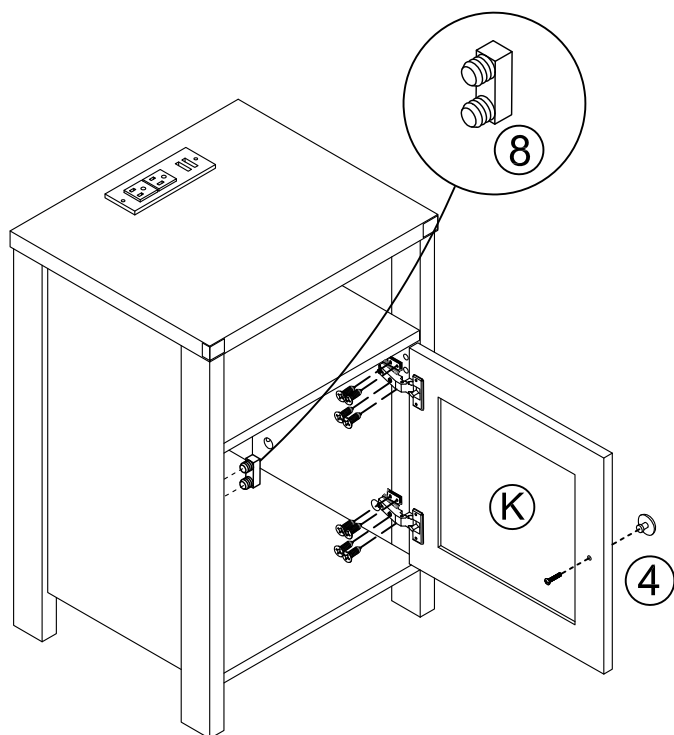
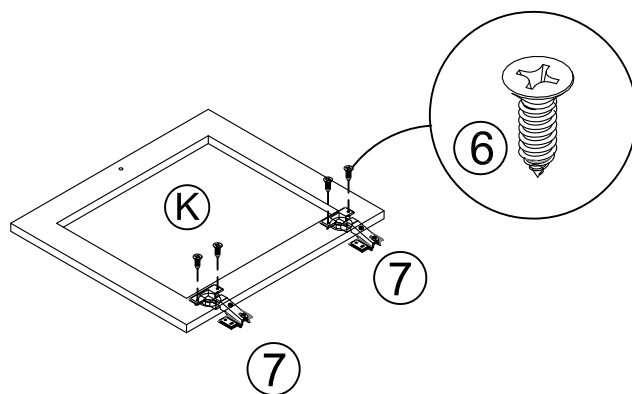
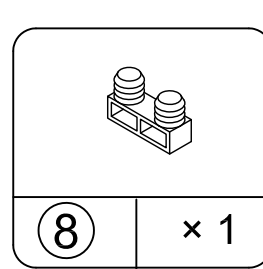
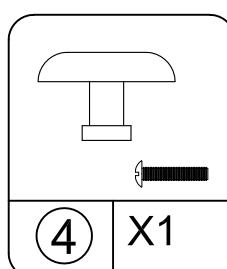
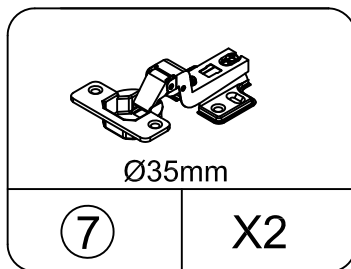
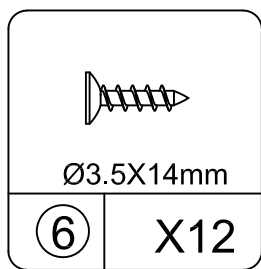
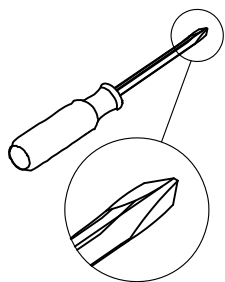

The door can be installed on any side as you want.

!!! Attention: please confirm that the door is installed correctly before installing part 8.

STEP 8

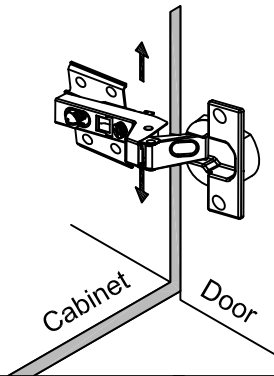
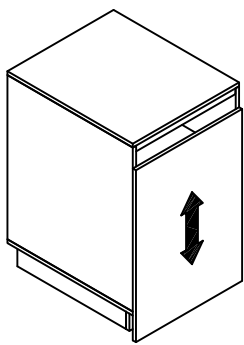
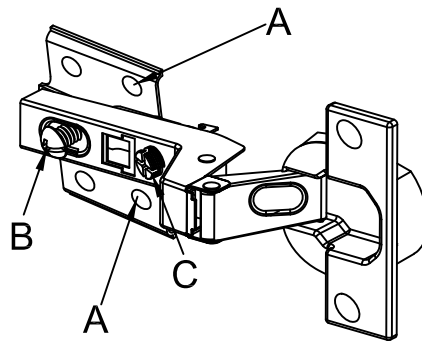

To adjust the vertical height.

Loosen the four screws "A" on both hinges. Two of them are usually in slotted holes which allows you to adjust up or down by a few mm. Then tighten back up.

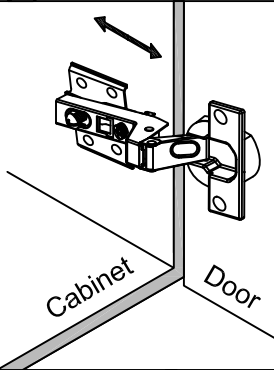
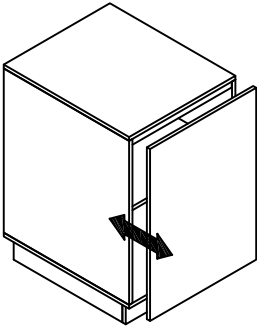

To adjust depth.

Loosen screw "B" and adjust door, if the door can not be adjusted, please loosen screw "C", then try again. Tighten screw "B" and "C".

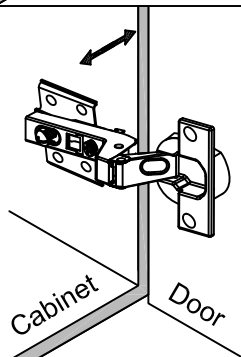
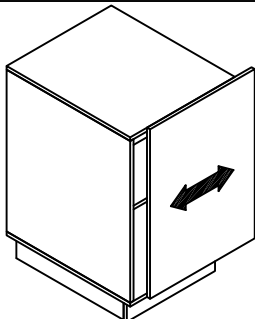

To adjust side ways.

Turning the screw "C" on BOTH hinges on each door.