

User Manual

Disassembly Diagram

The installation would be easier if completed by two people.

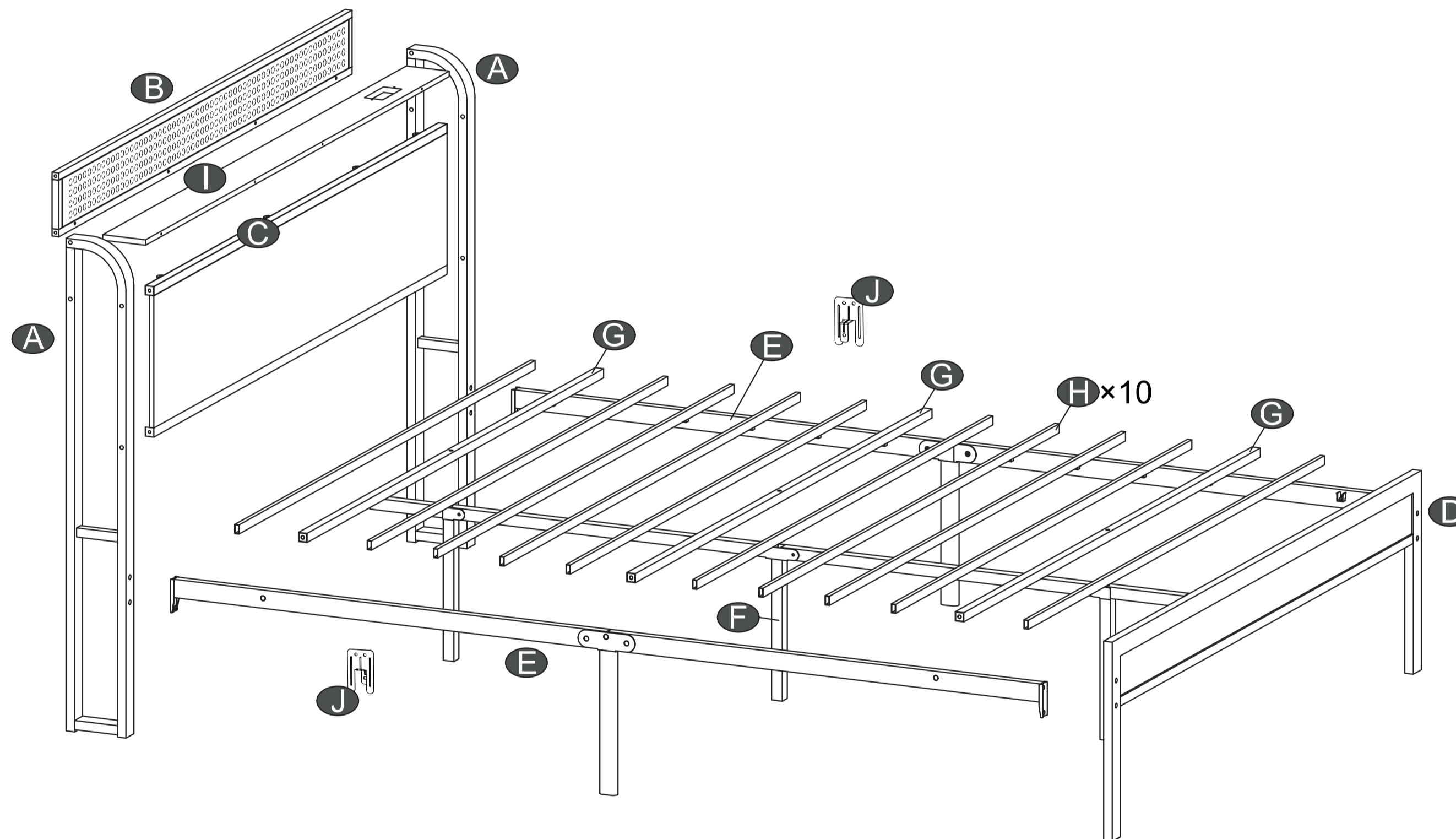
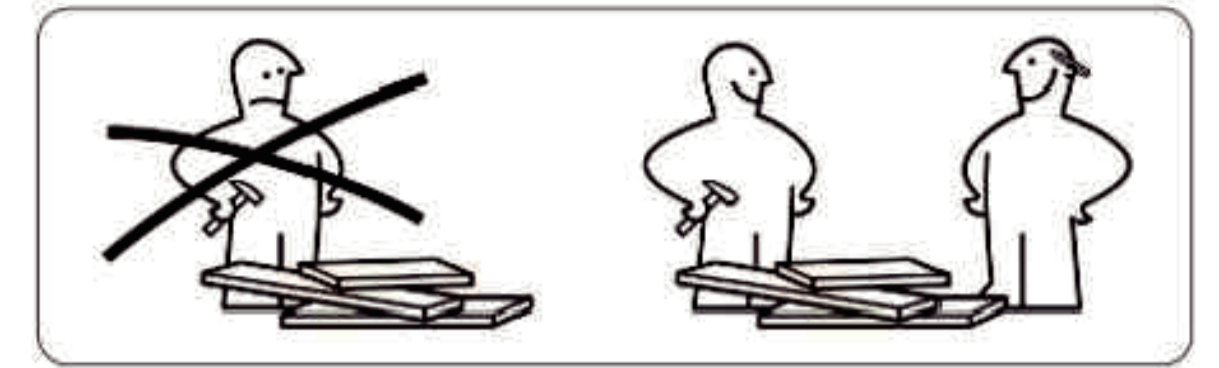

Before assembly, please read the USER MANUAL thoroughly for quick assembly, and check according to Accessories.

If you have any concerns or questions during installation or about product itself, please feel free to contact us

Accessories

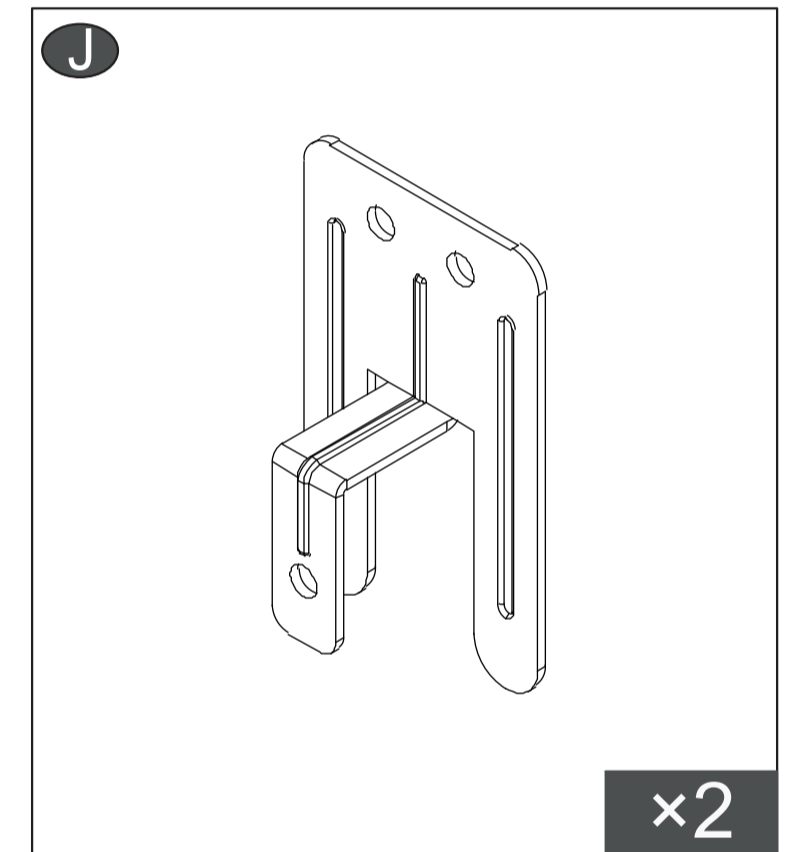
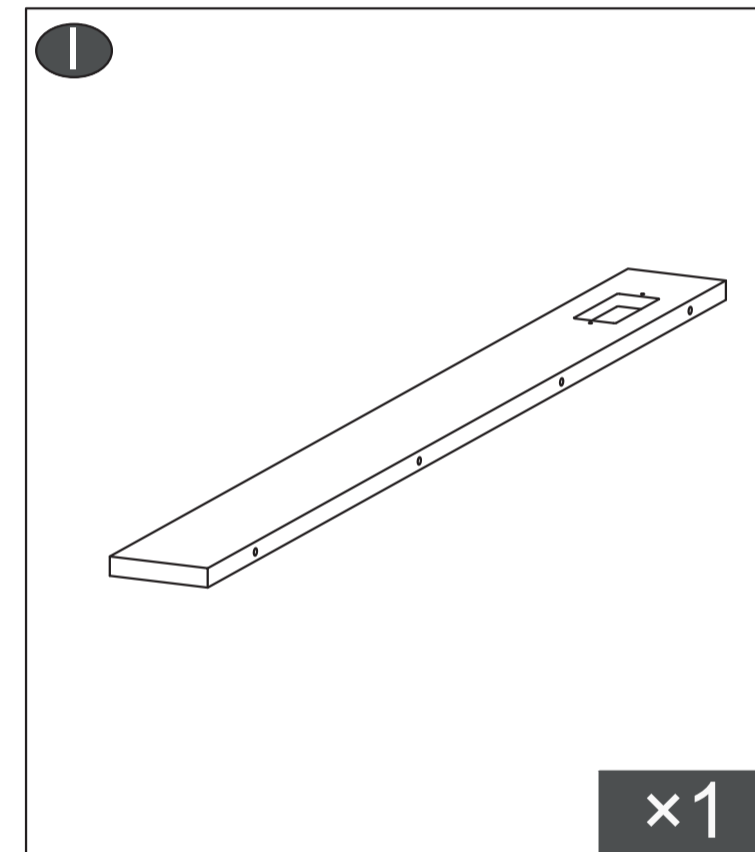
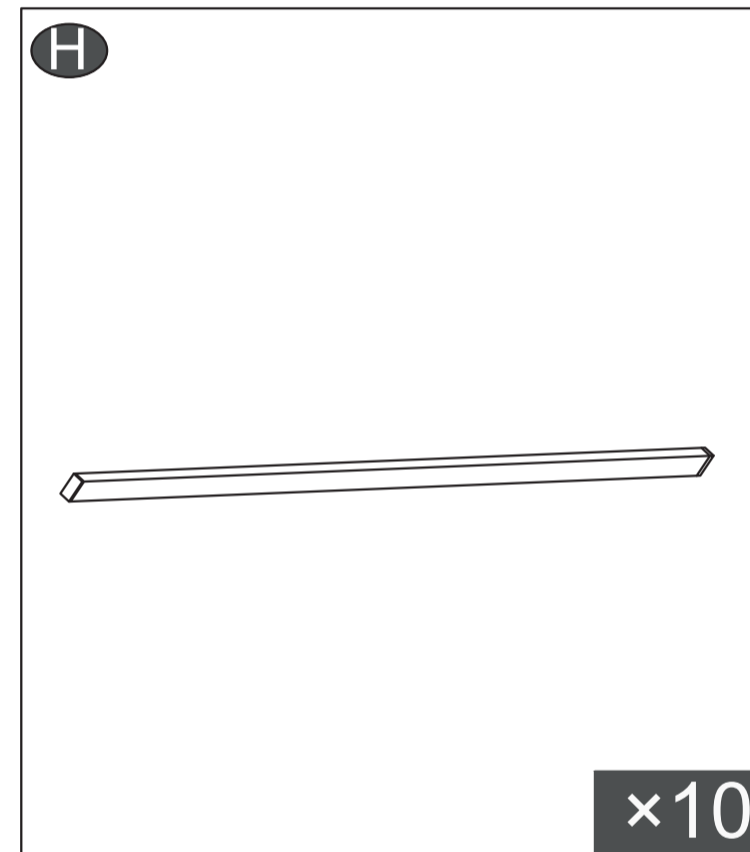
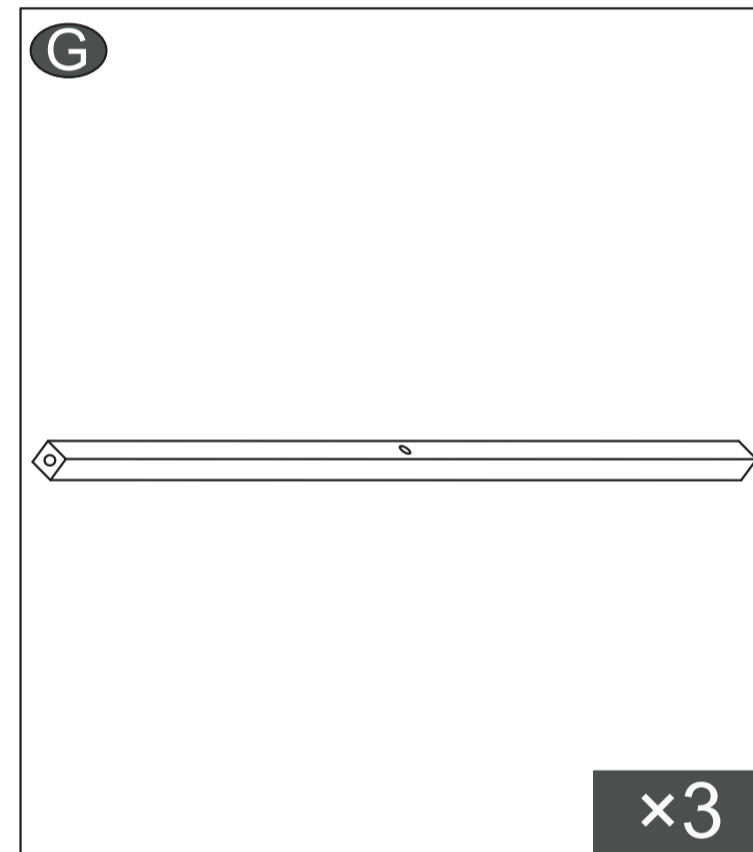
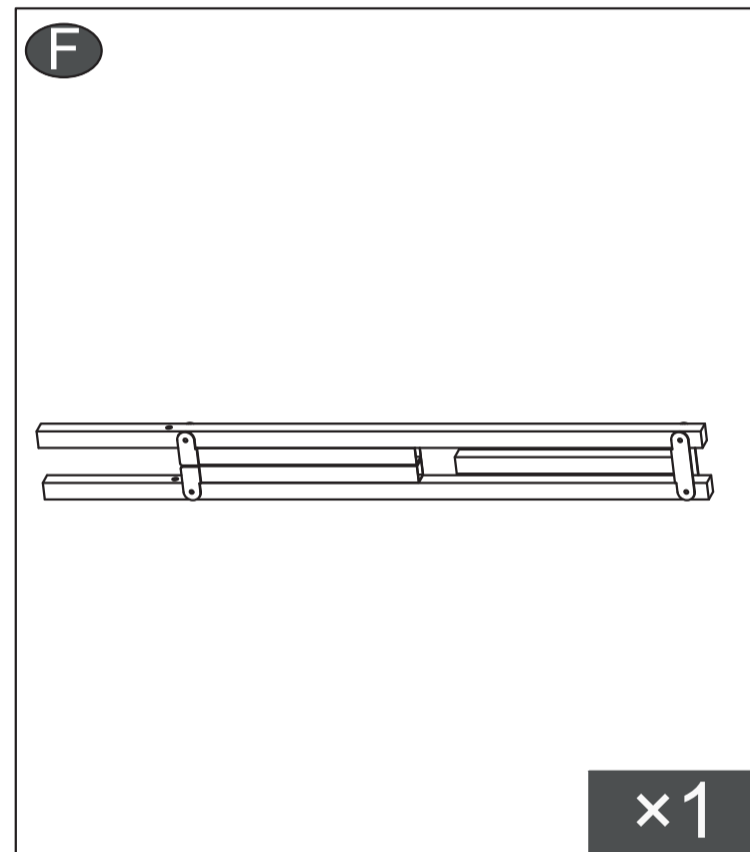
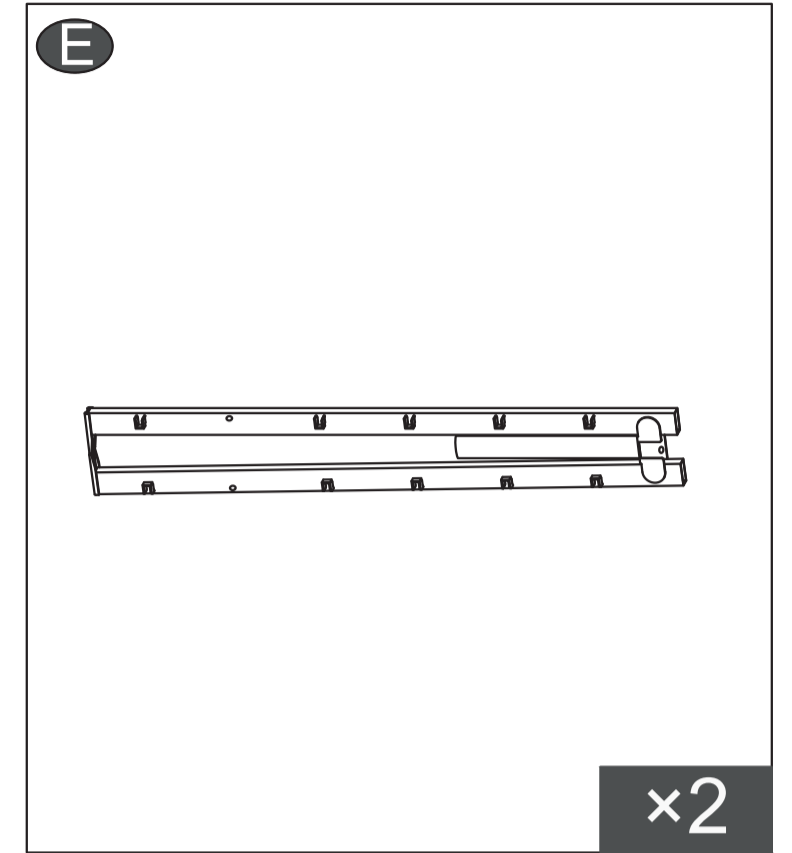
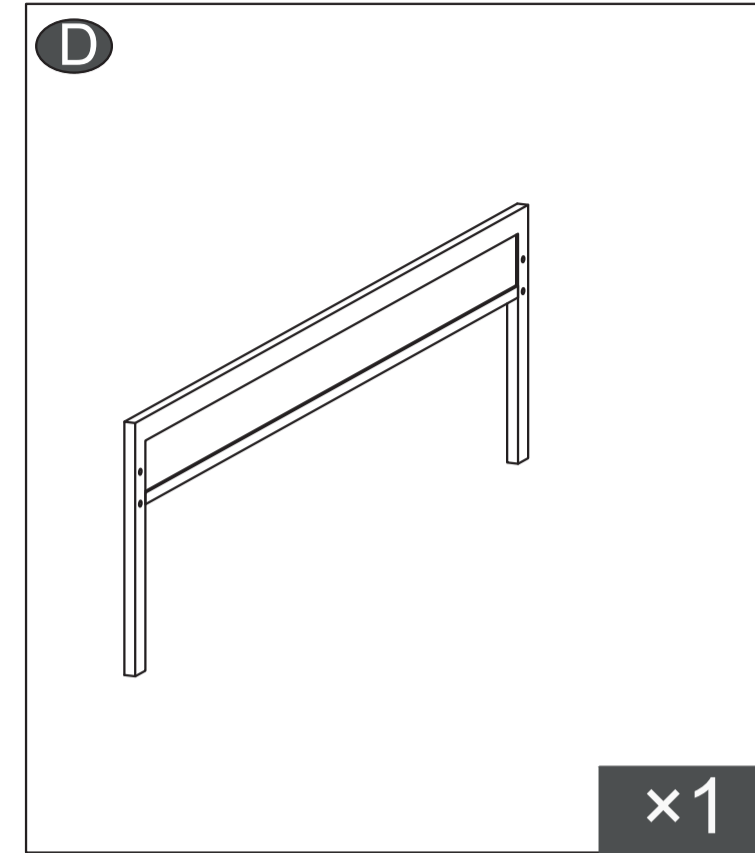
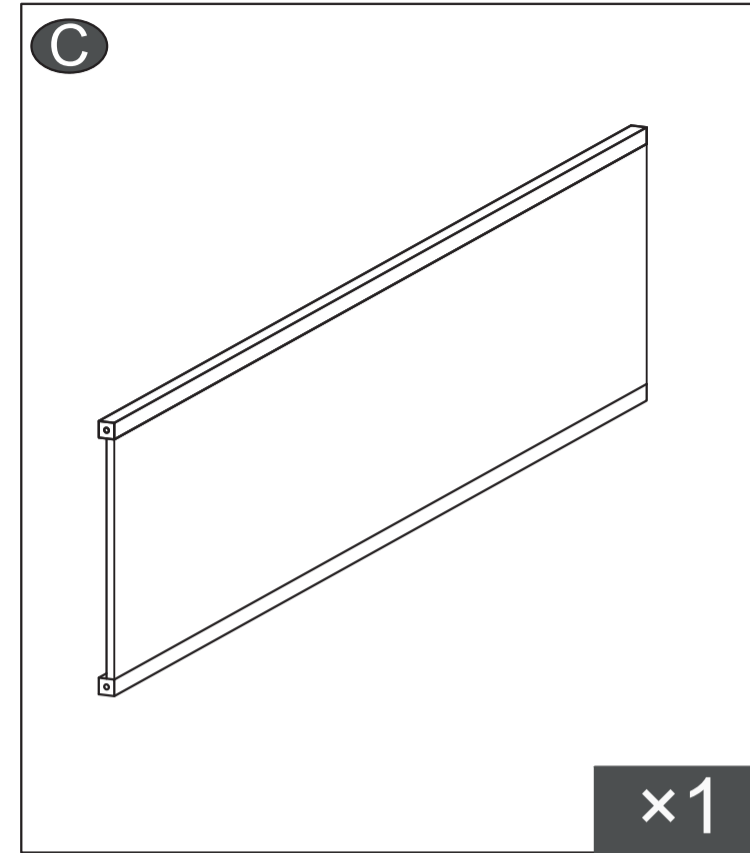
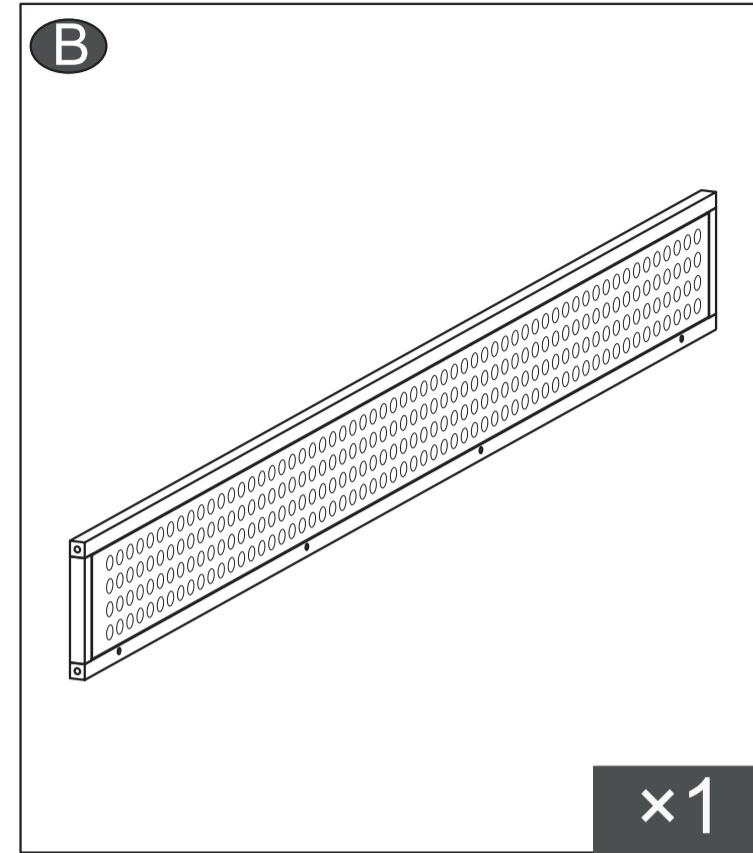
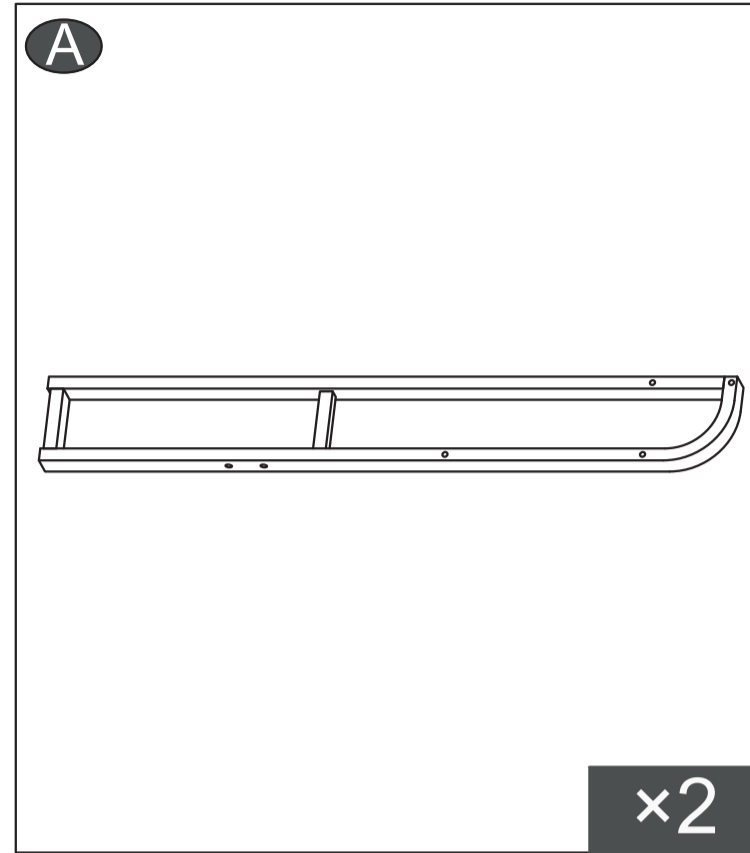

Accessories

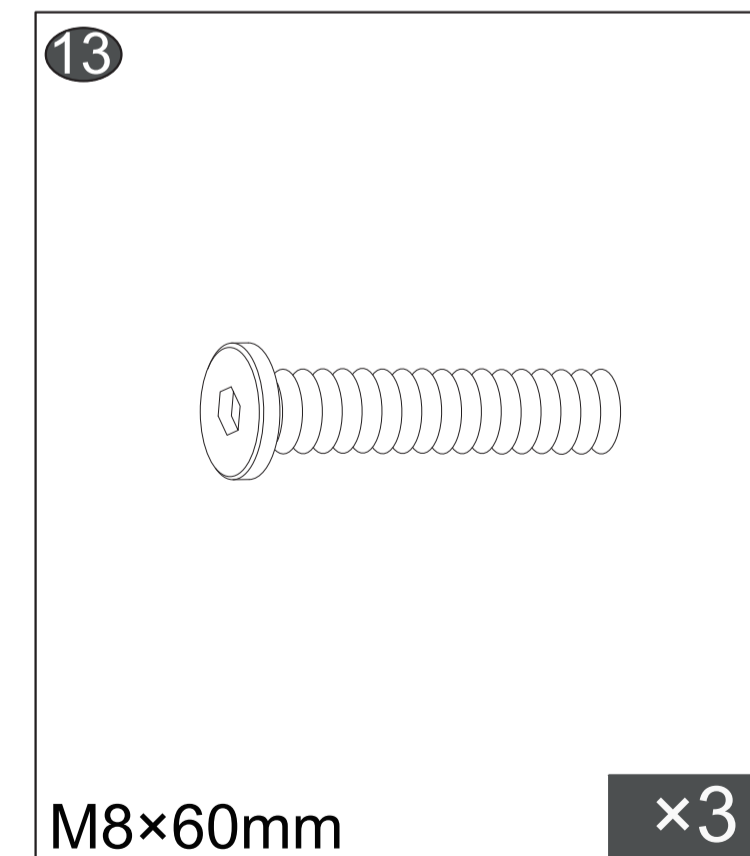
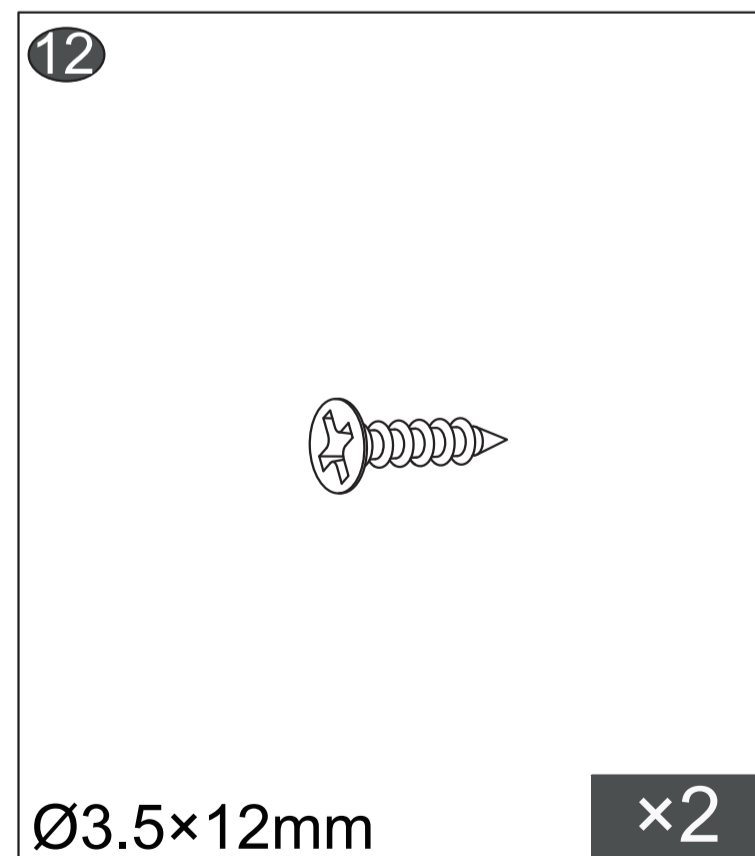
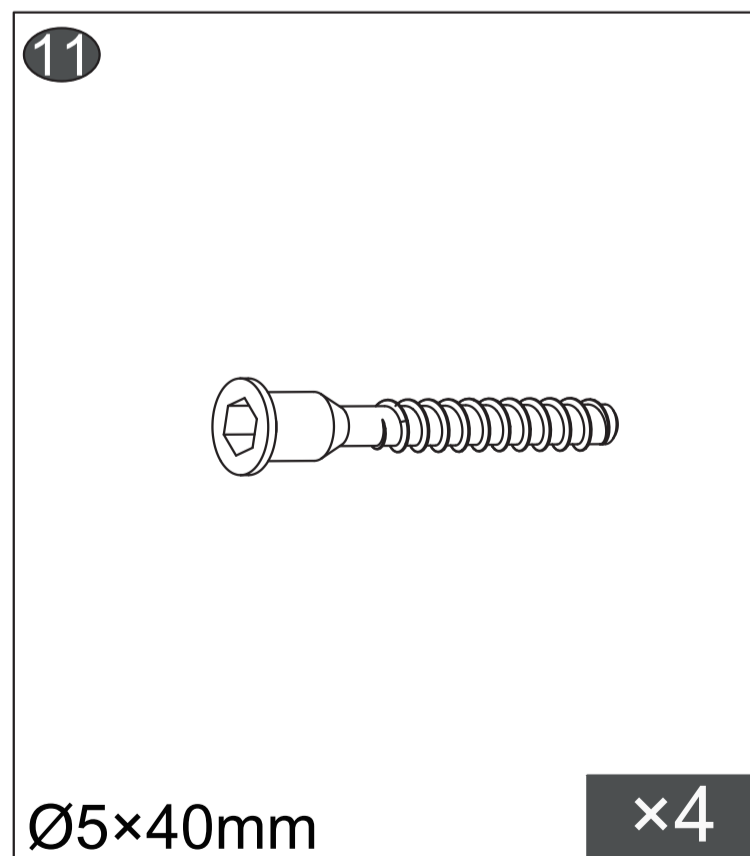
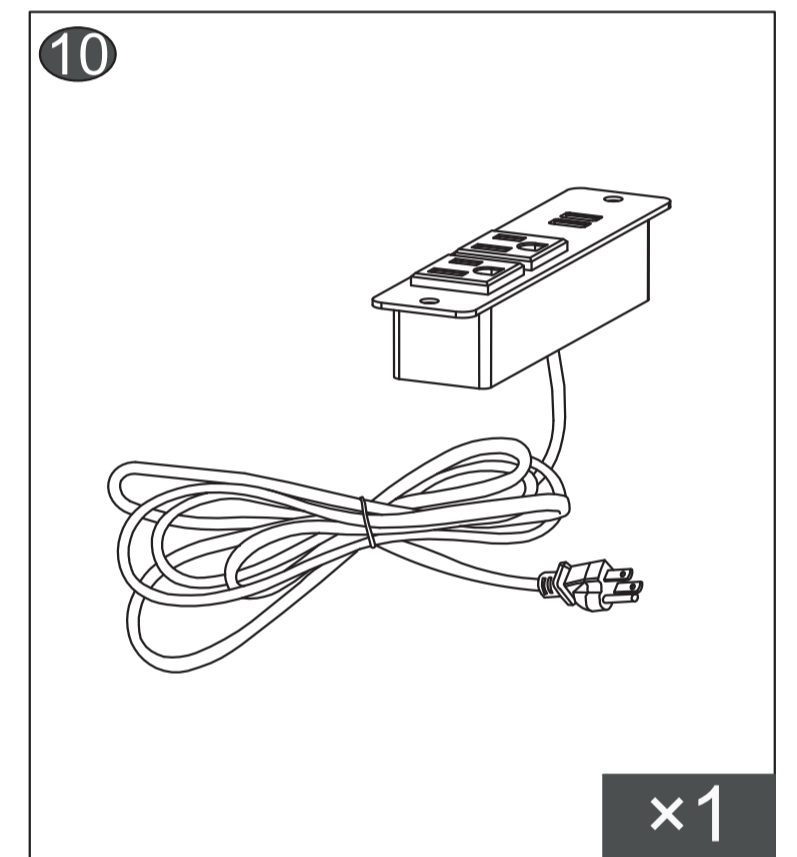
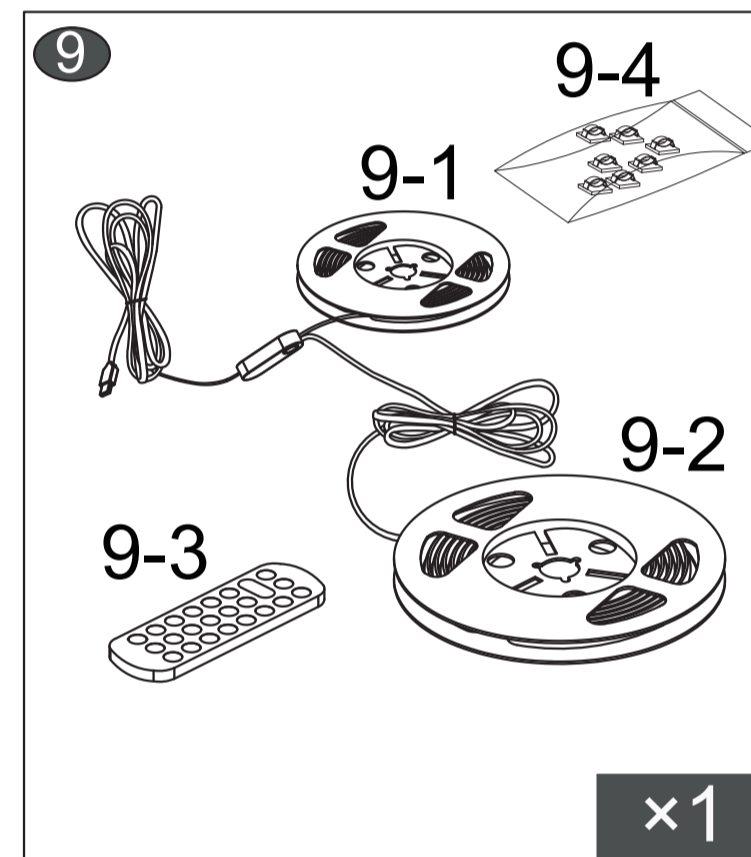
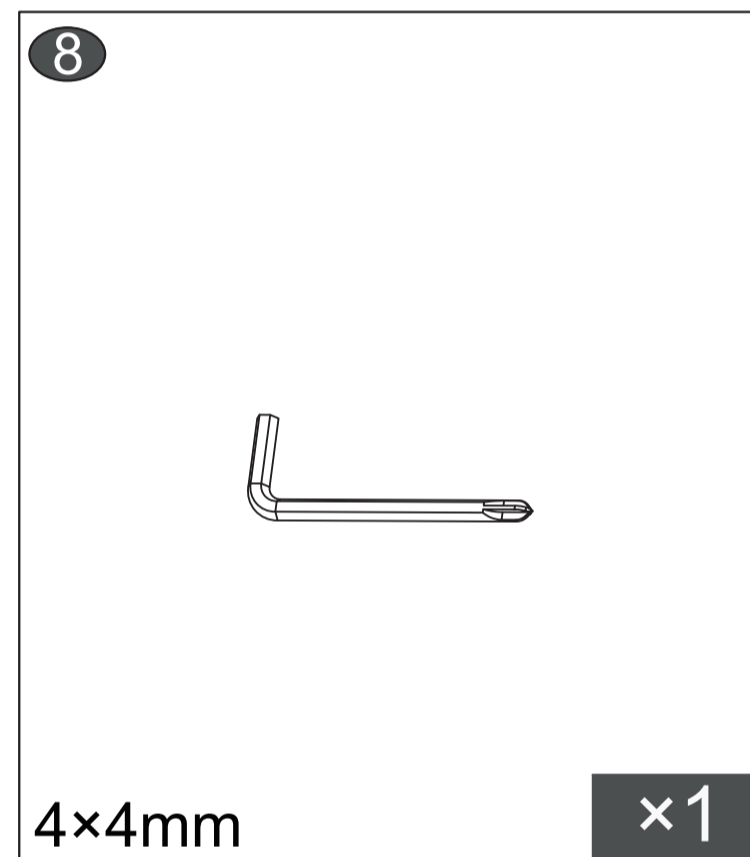
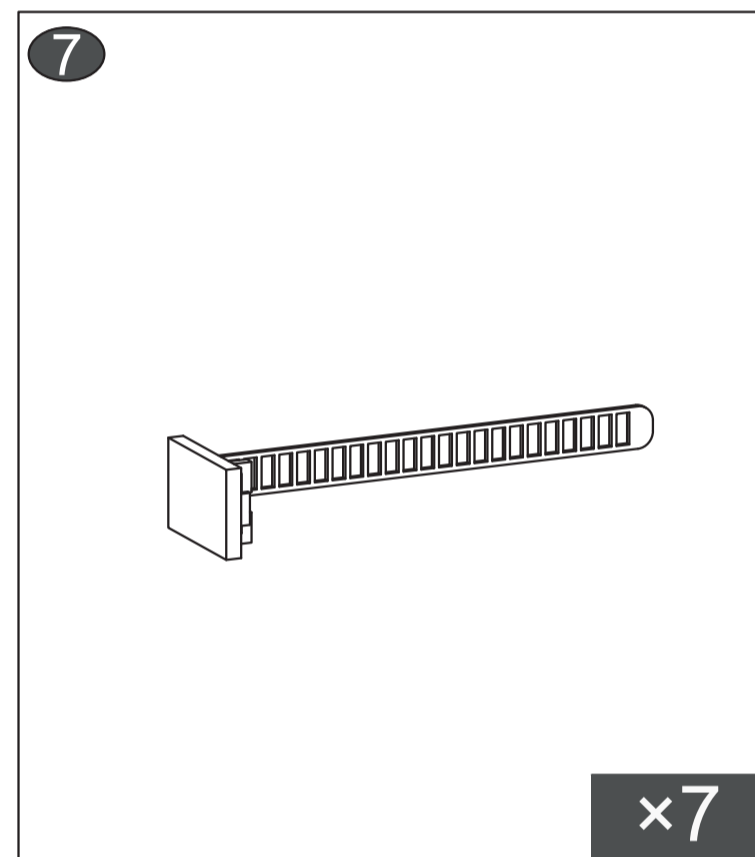
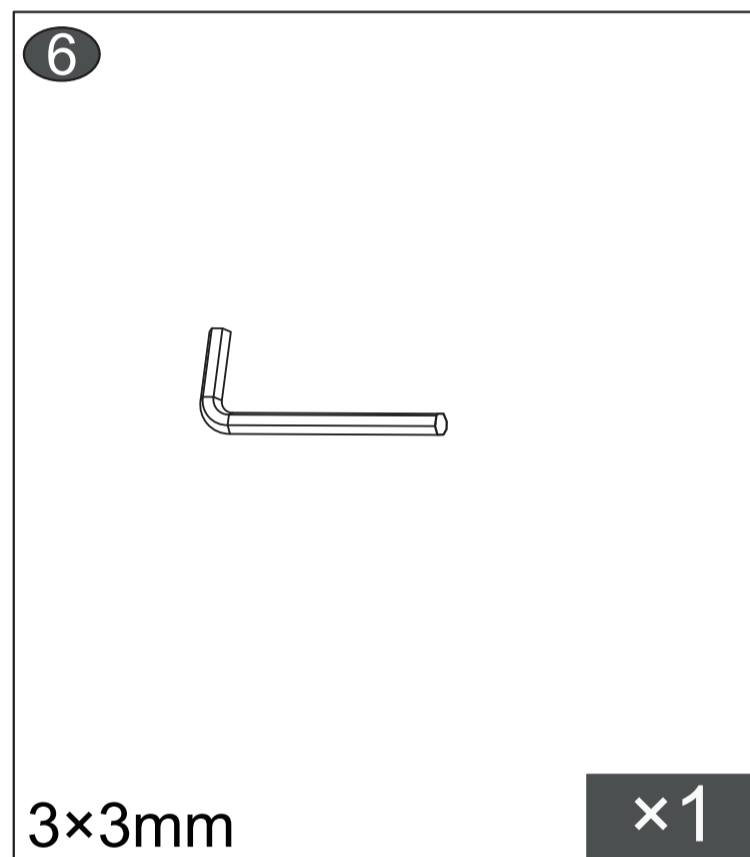
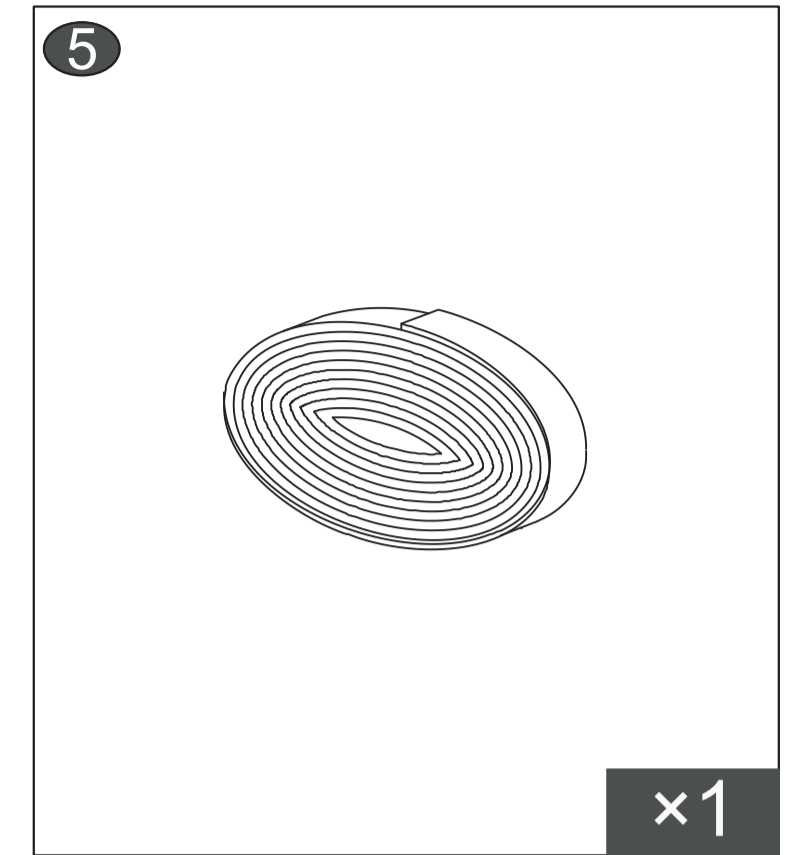
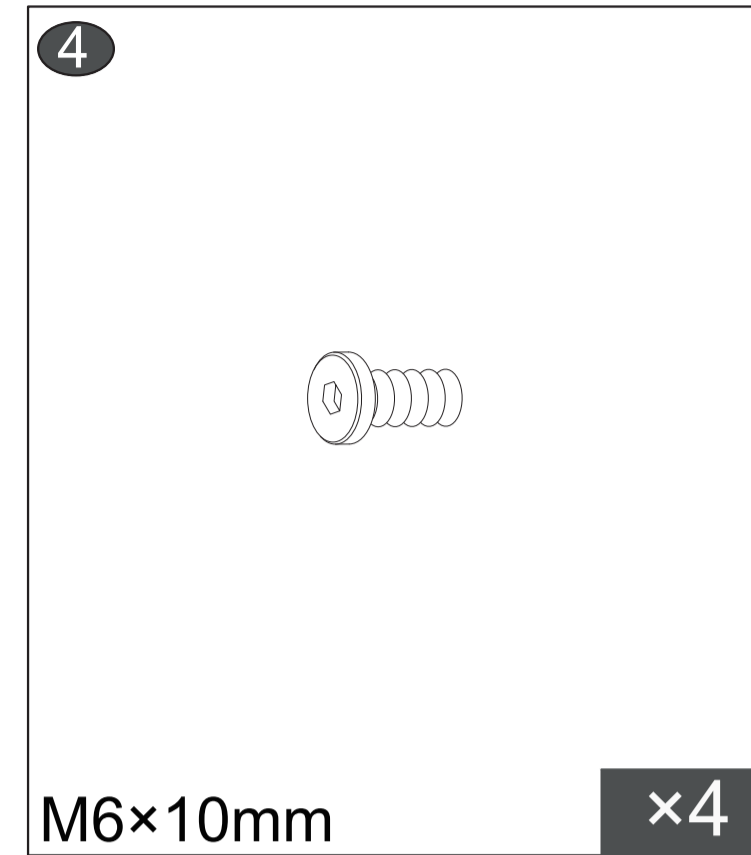
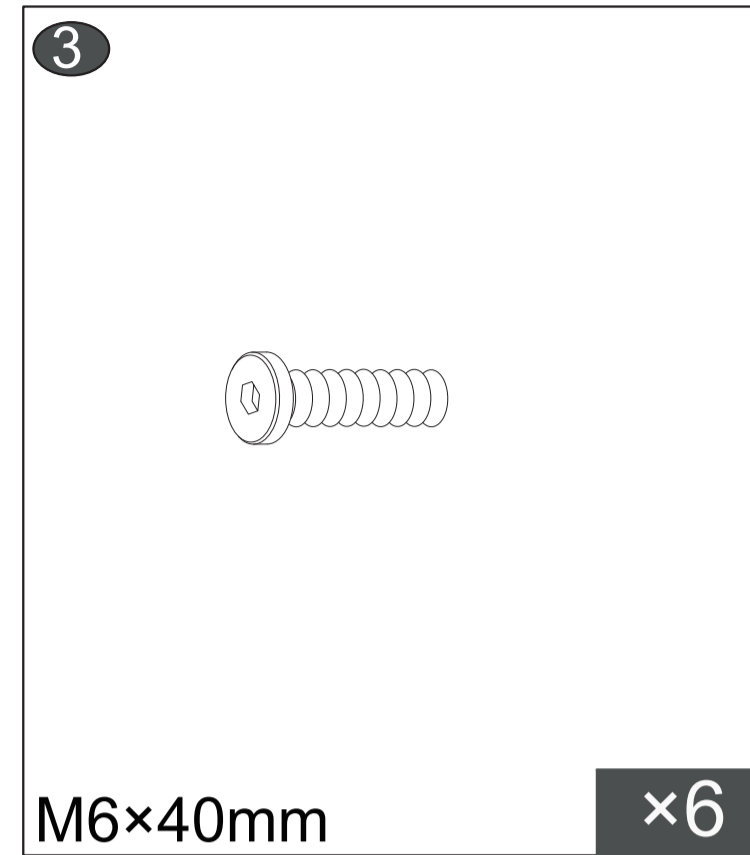
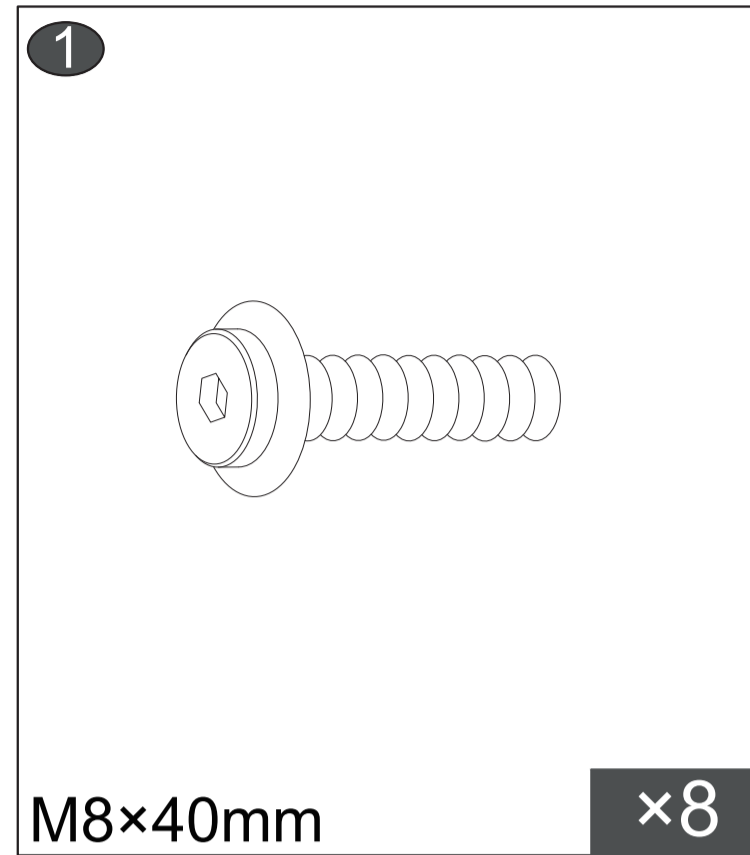

If the screws that we've provided does not match your bed frame, please contact us:

 step 1

Secure the metal mesh board **B** and wood board **C** between the frame **A** with screws **2**

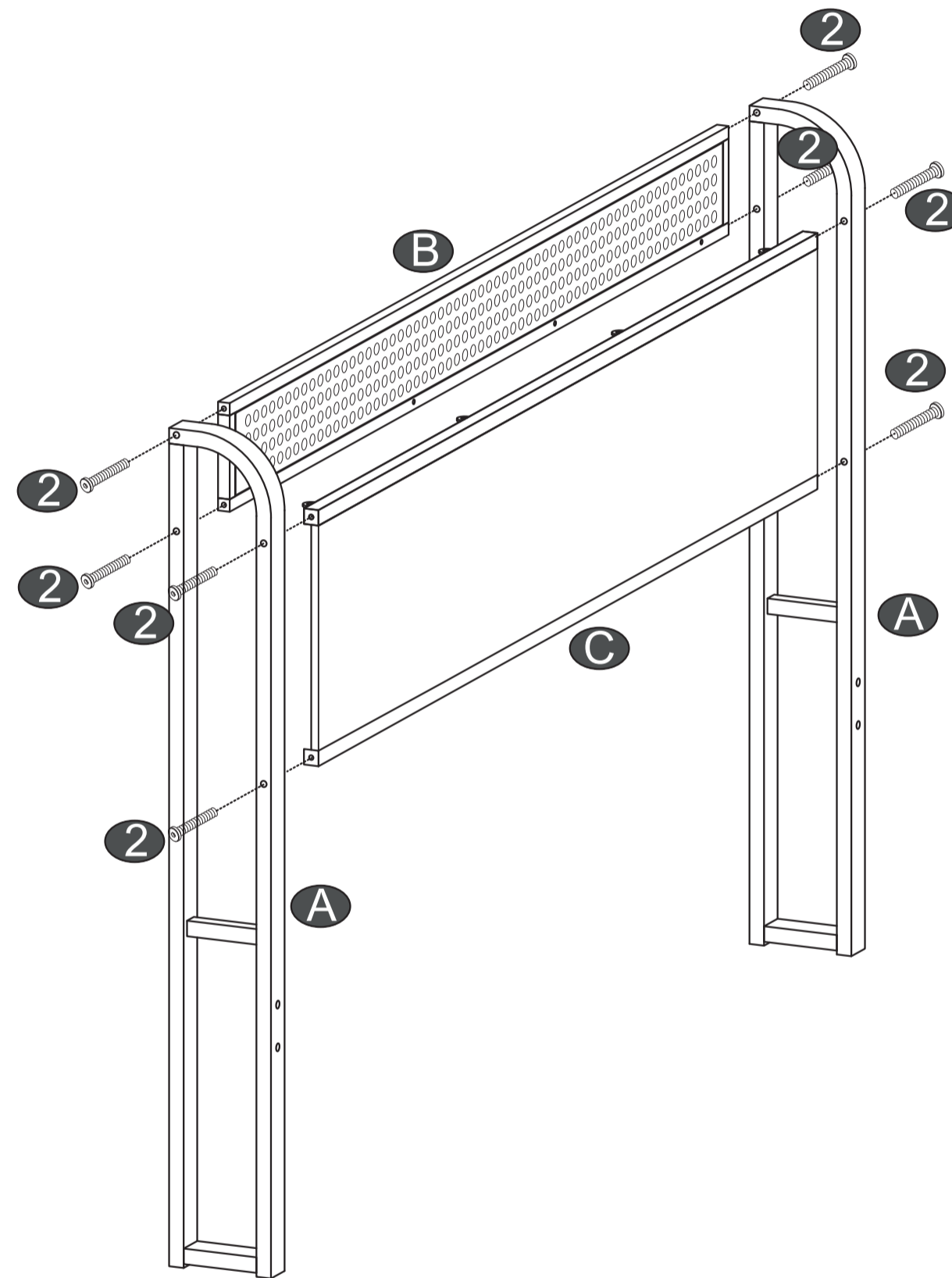

Please tighten the bolts to 80% first, and tighten all bolts 100% after all parts are assembled.

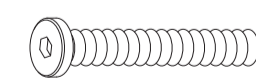
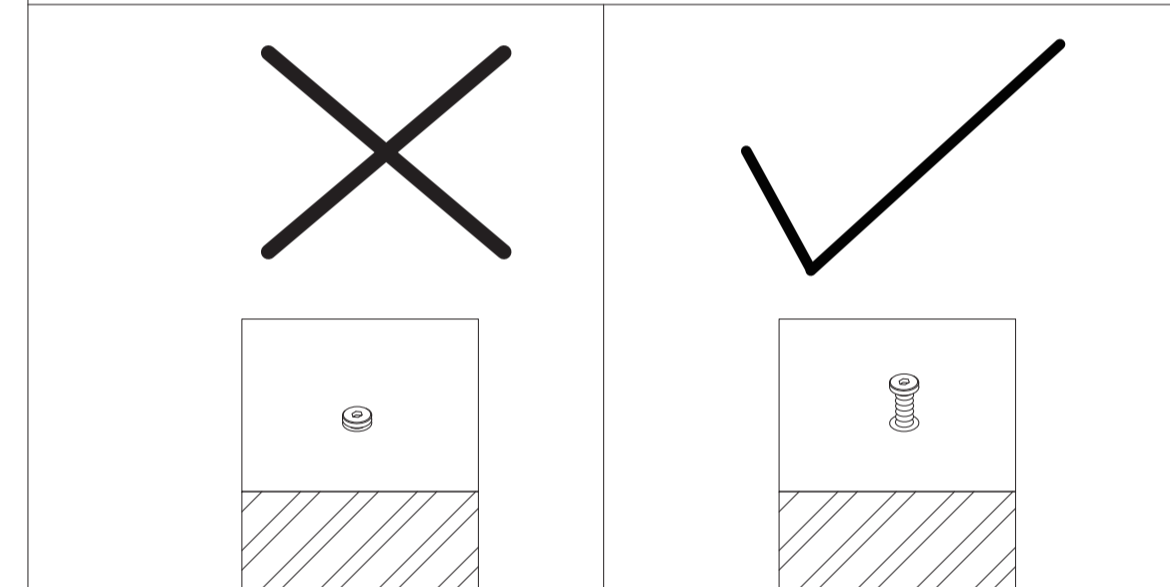

2 × 8pcs



8 × 1pc

 **step 2**

Fix the wood top board **I** on the metal frame **C** (from the back side of the frame) with screws **4**

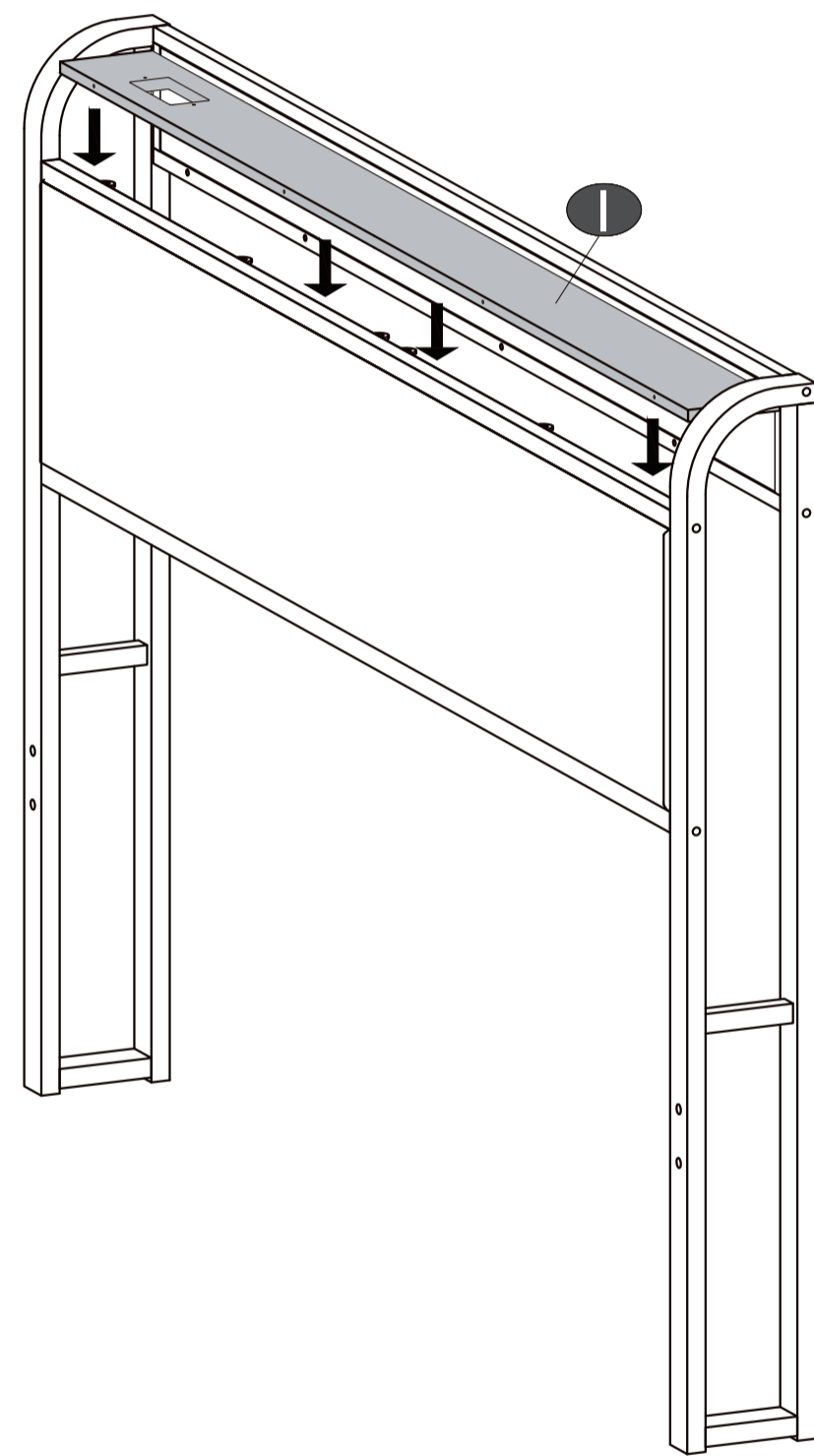

or

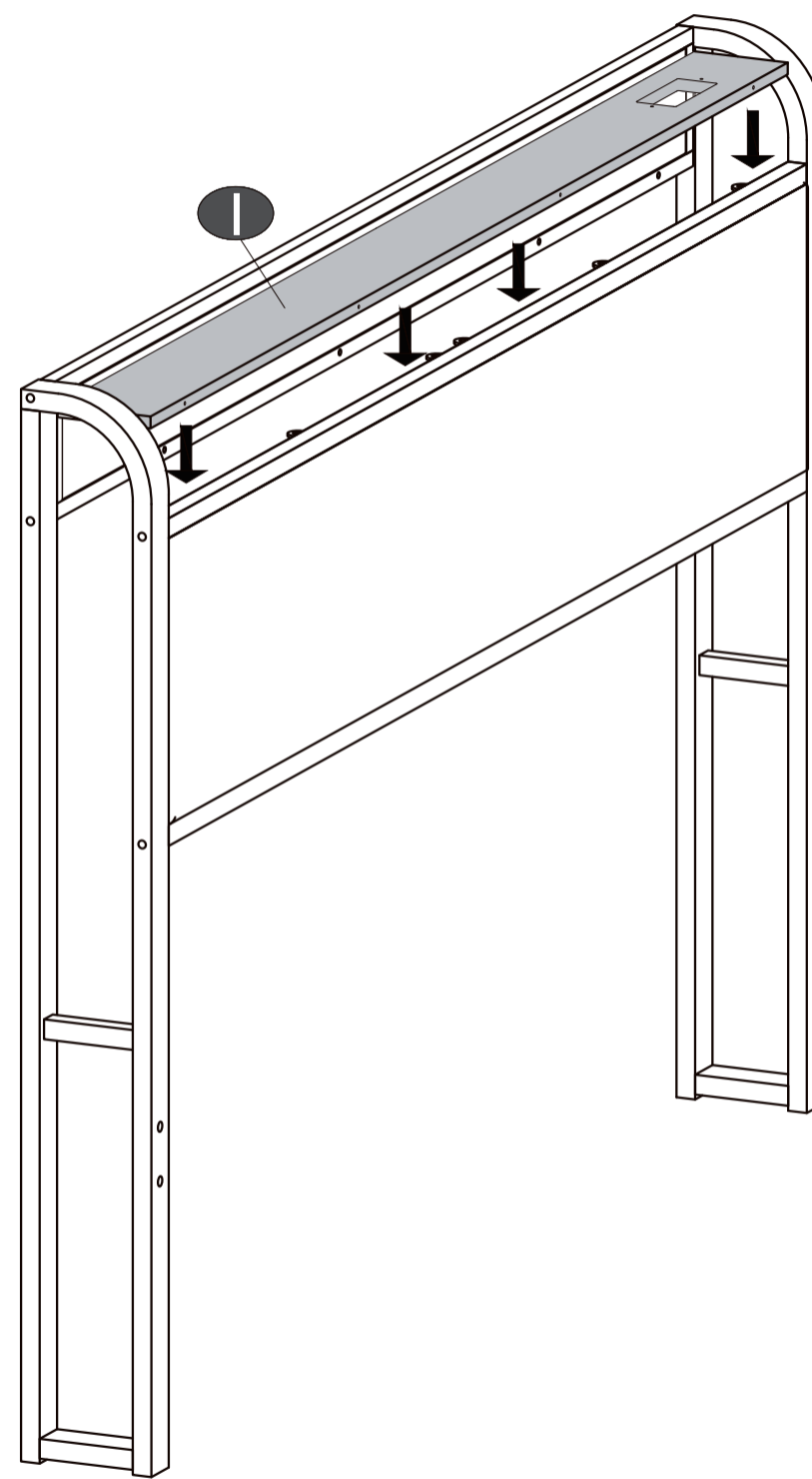

Turn to the back side

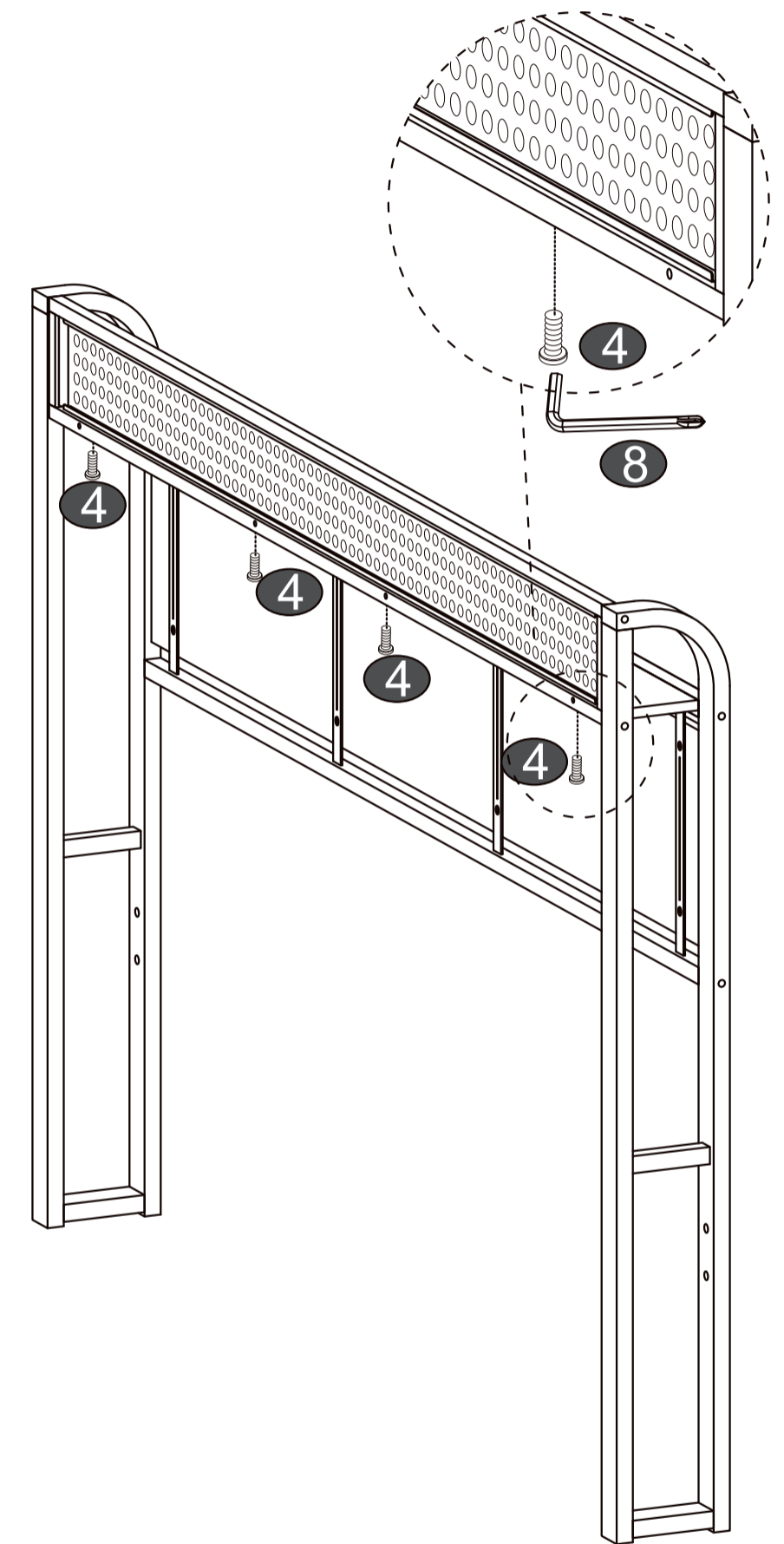

 **step 3**

Fix the wood top board **I** on the mesh board **B** (from back) with screws **11**

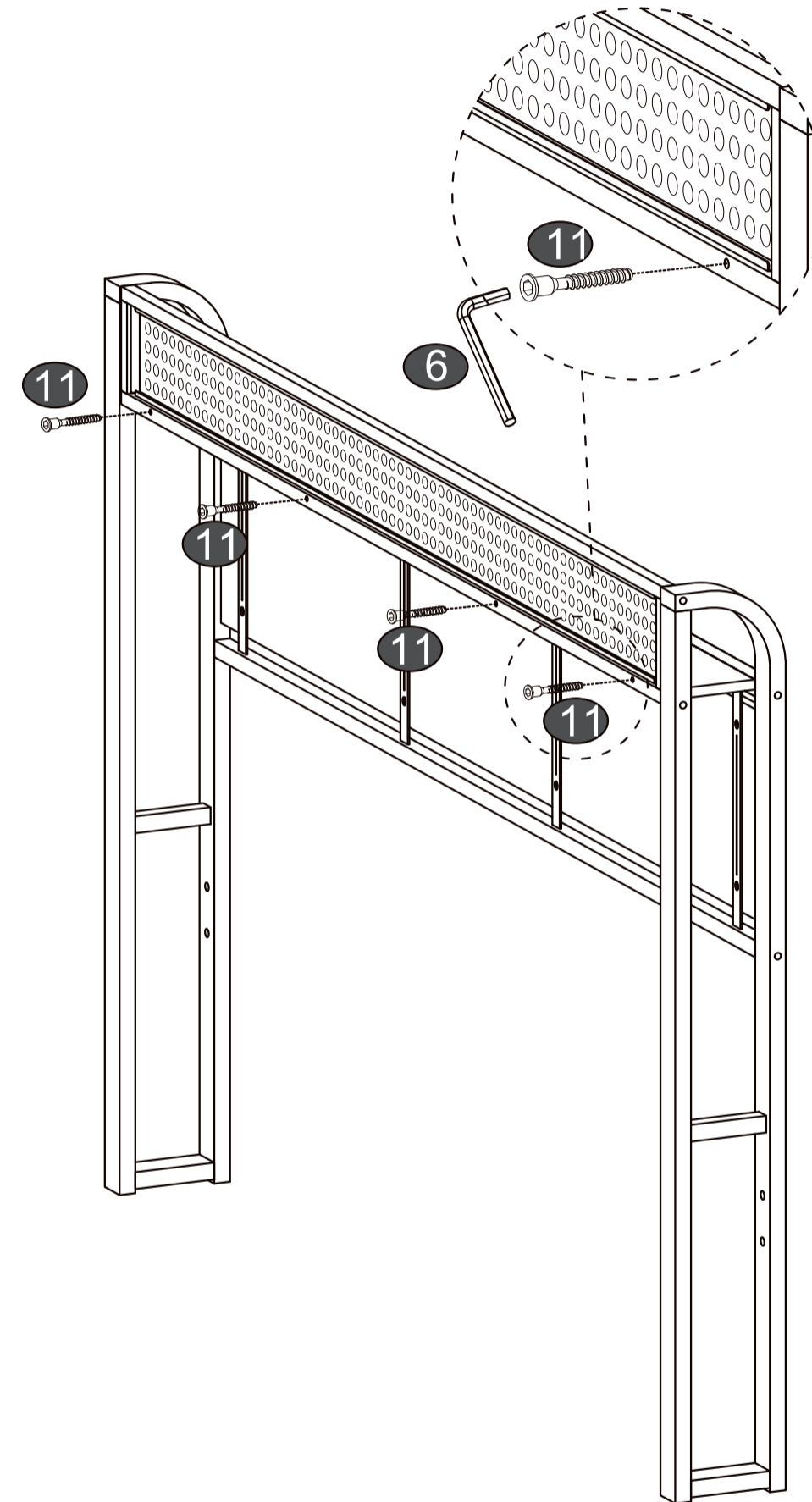

3

 **11** x4pcs  3x3mm
6 x1pc

 **step 4**

Unfold the bed edge frame **E**

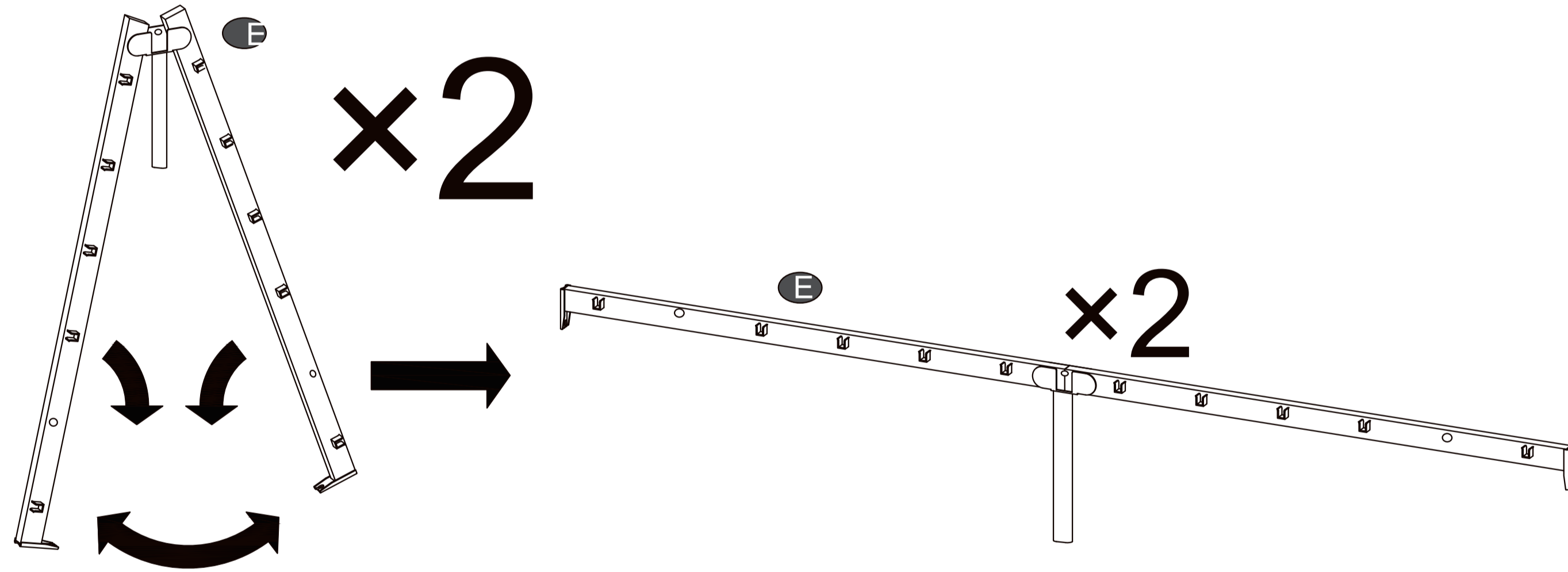

 **step 5**

Fix the bed edge frame **E** on the bed frame with screws **1**

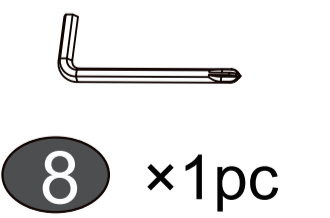
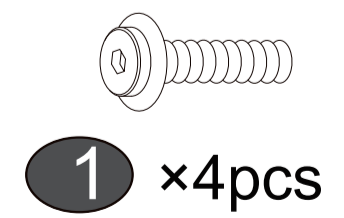
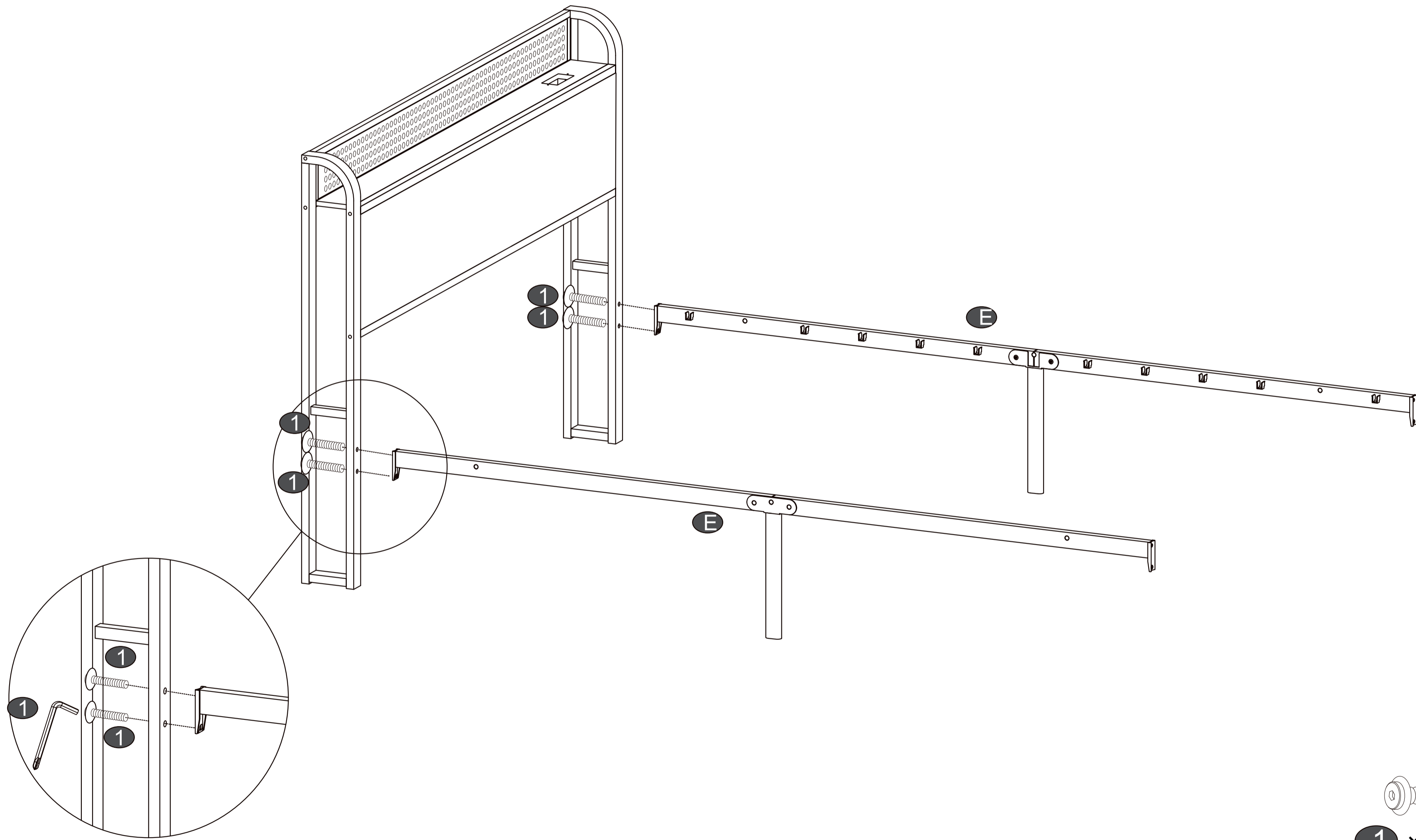

 **step 6**

Glue 9-4 self-adhesive ties evenly to parts **D** for future use.

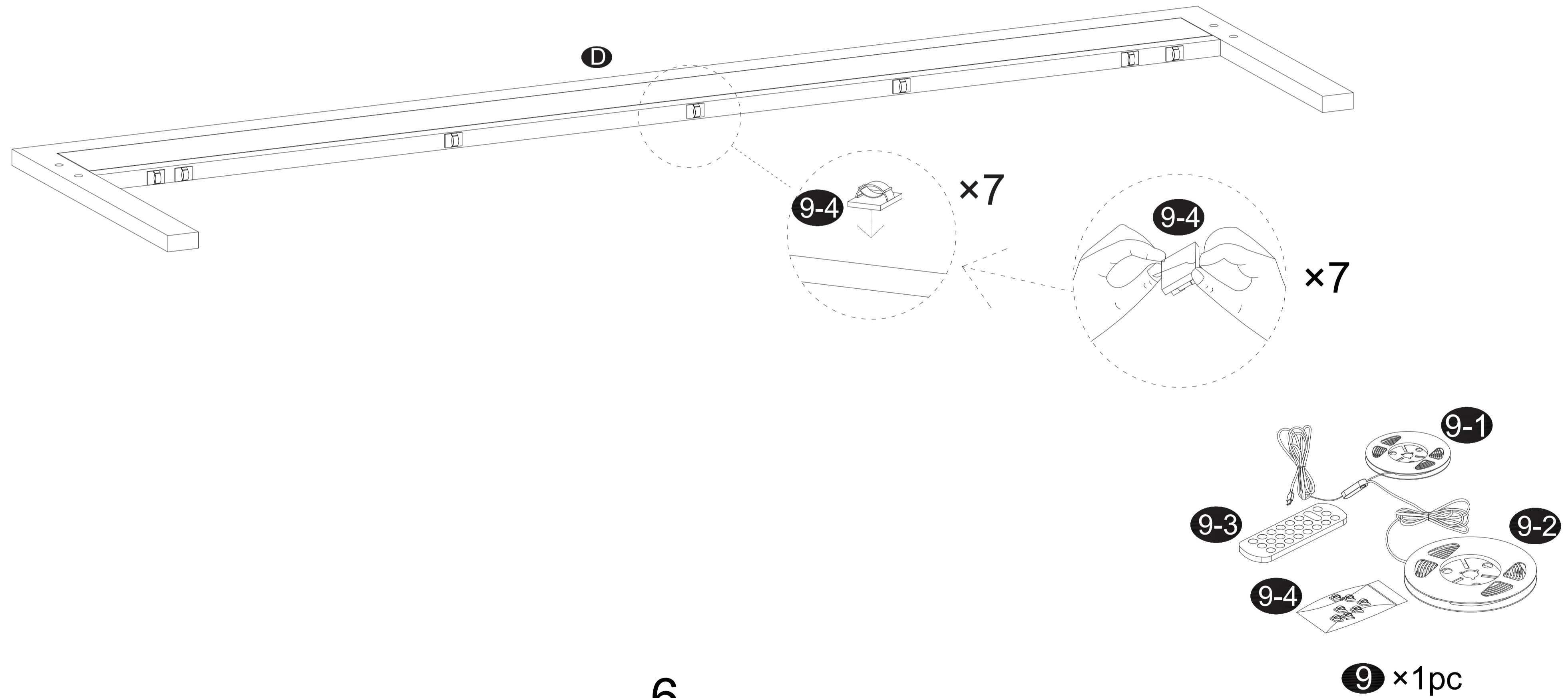

 **step 7**

Fix another side bed edge frame **E** on the footboard **D** with screws **1**

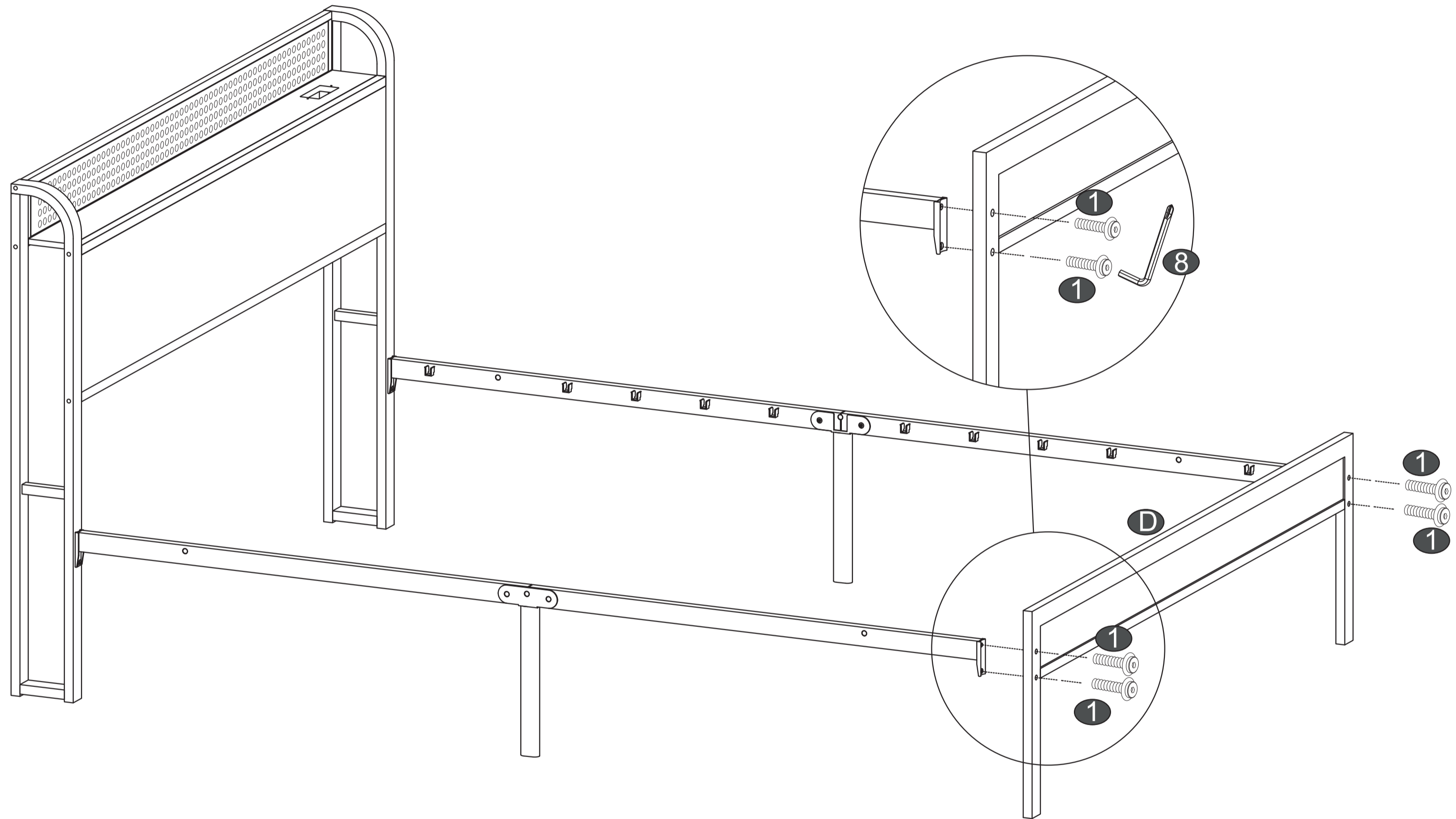

-  **1** × 4 pcs  **8** × 1 pc

 **step 8**

Locked the horizontal stick **G** with screws **3**

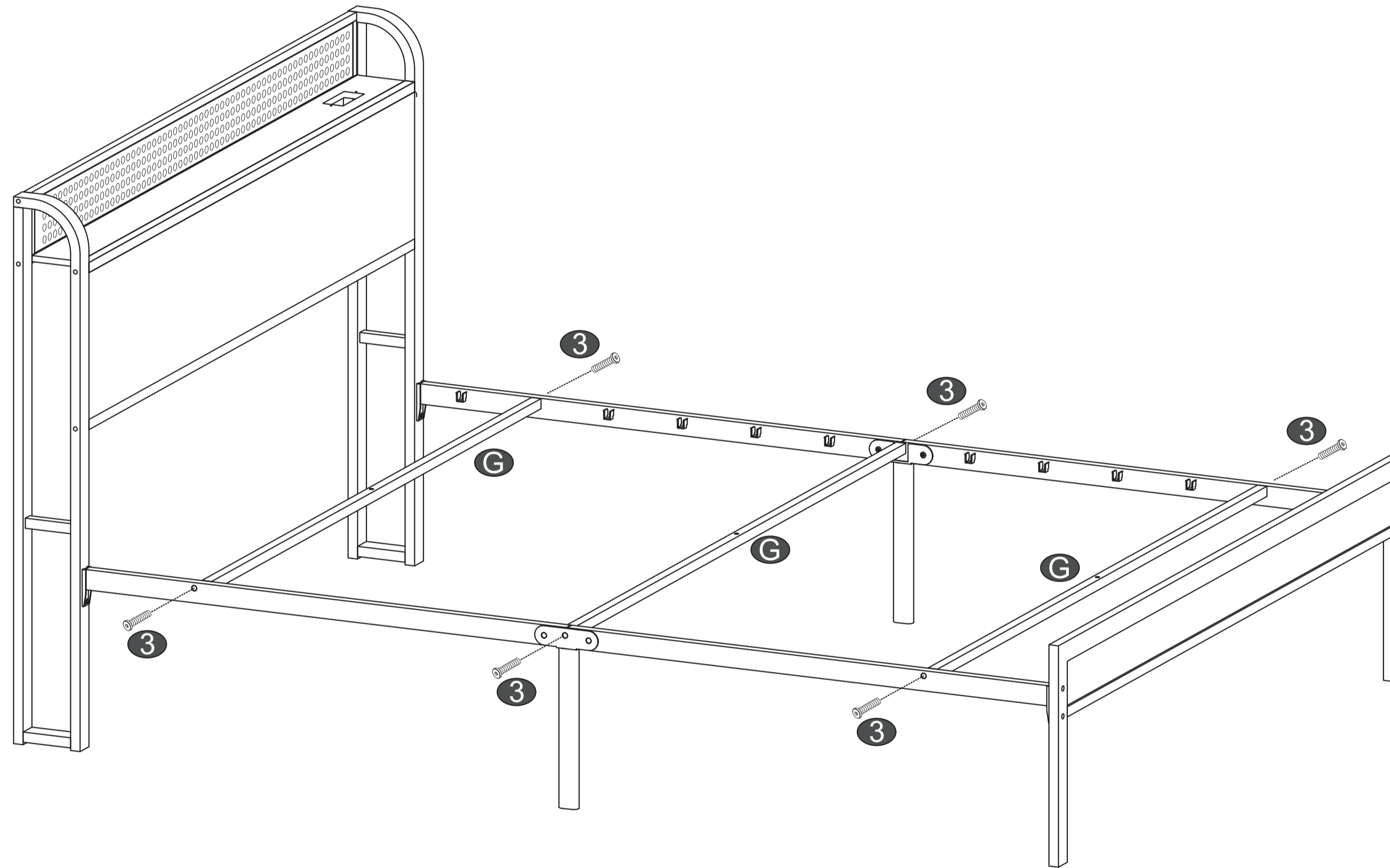

 **step 9**

Unfold the middle support frame **F**

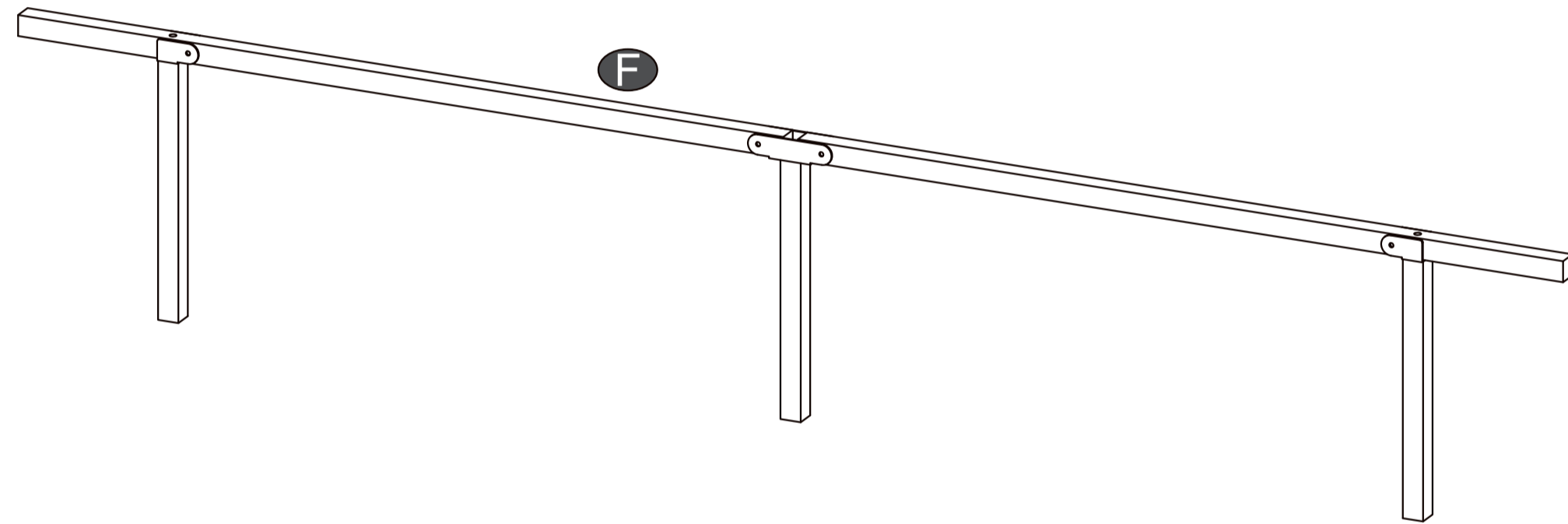
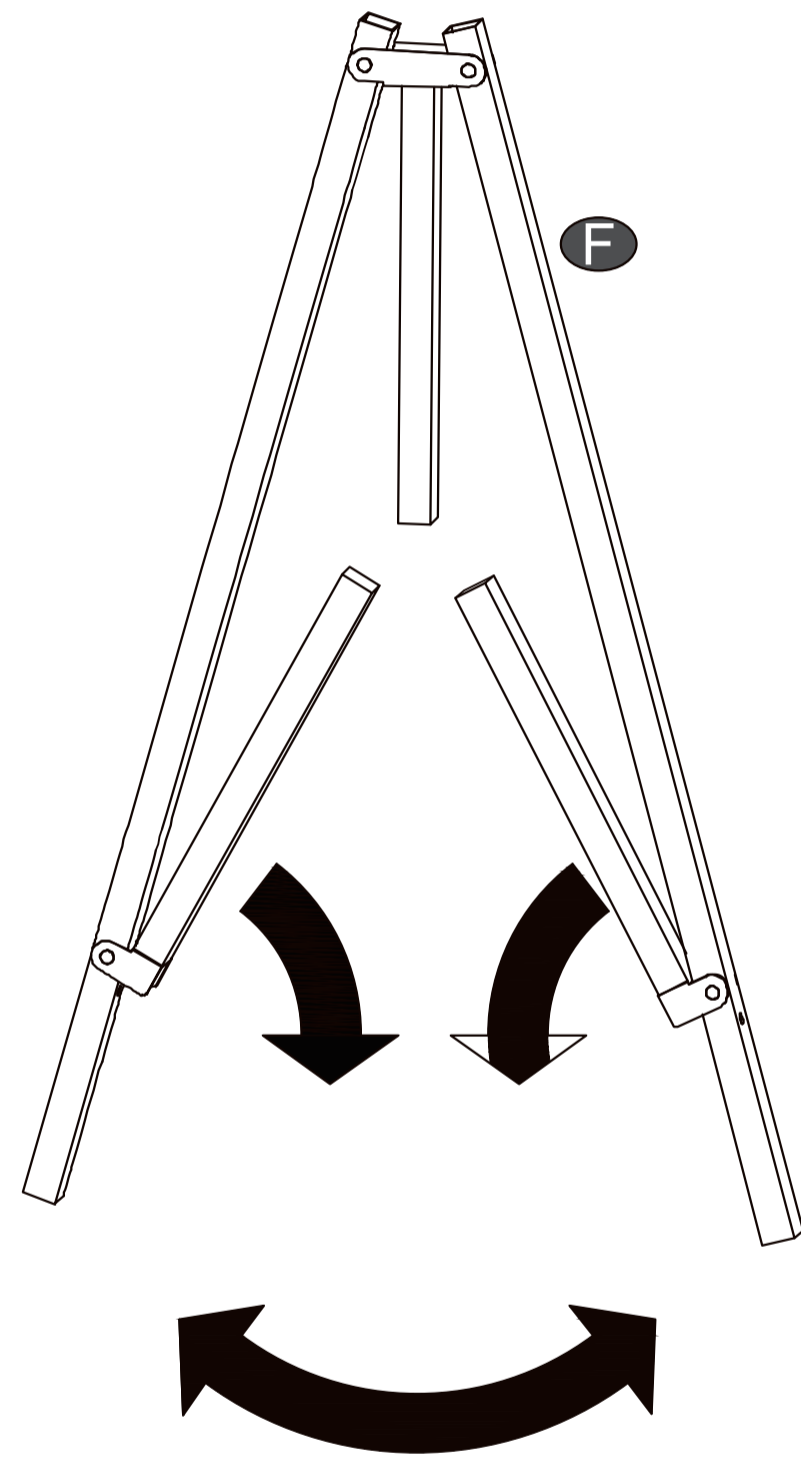

 **step 10**

Fix the vertical stick **F** on the horizontal stick with screw **13**, paste the silence foam **5** on the stick **F**

2.To prevent friction noise, unroll part **5** and fit it on part **F** ,the lenght of part **5** can cut as you will.

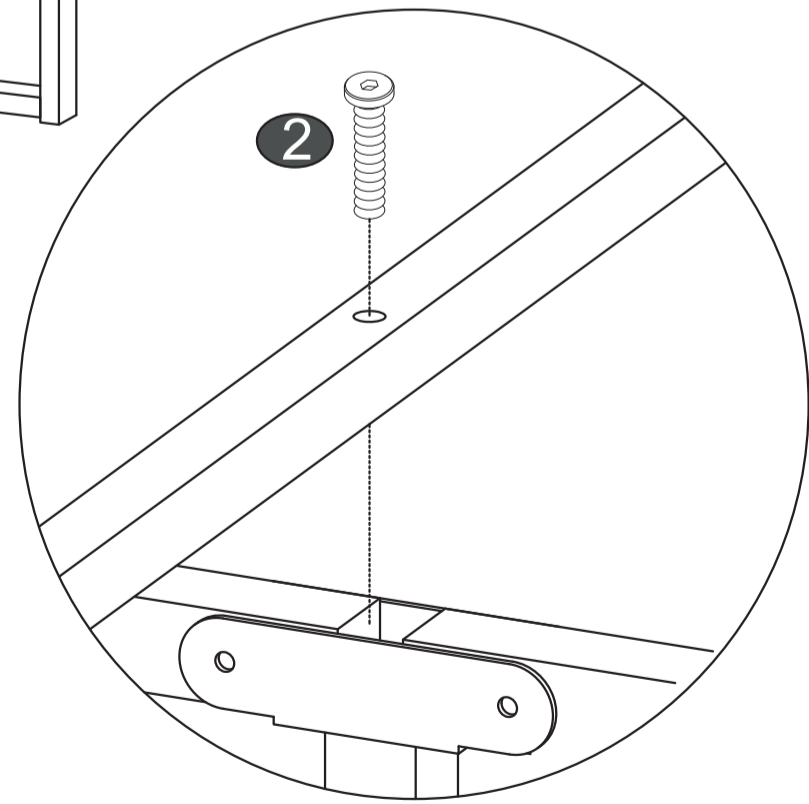
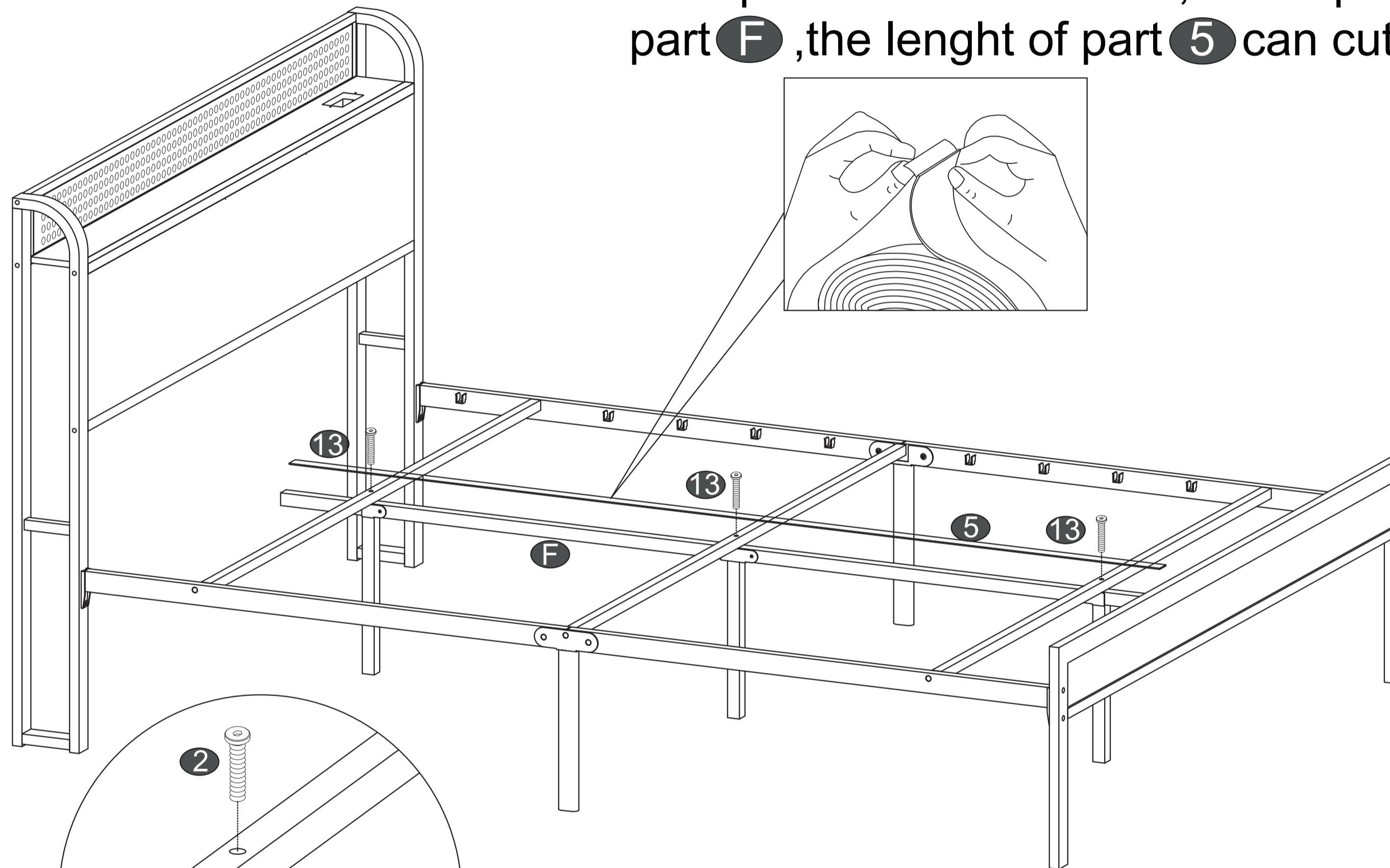

1.Tighten screw **2** .

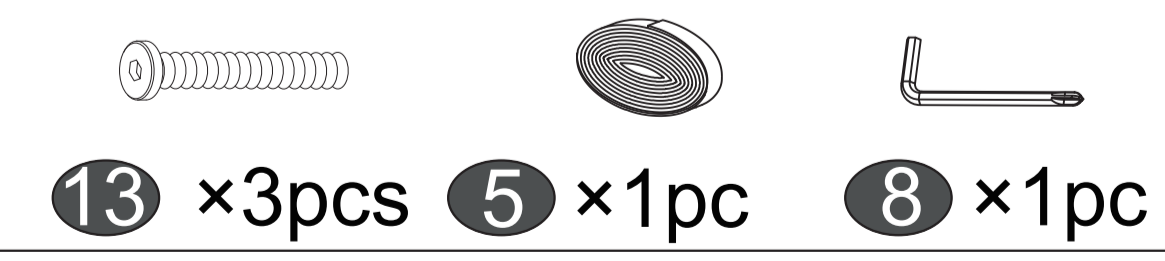

 **step 11**

Embed the metal stick **H**.

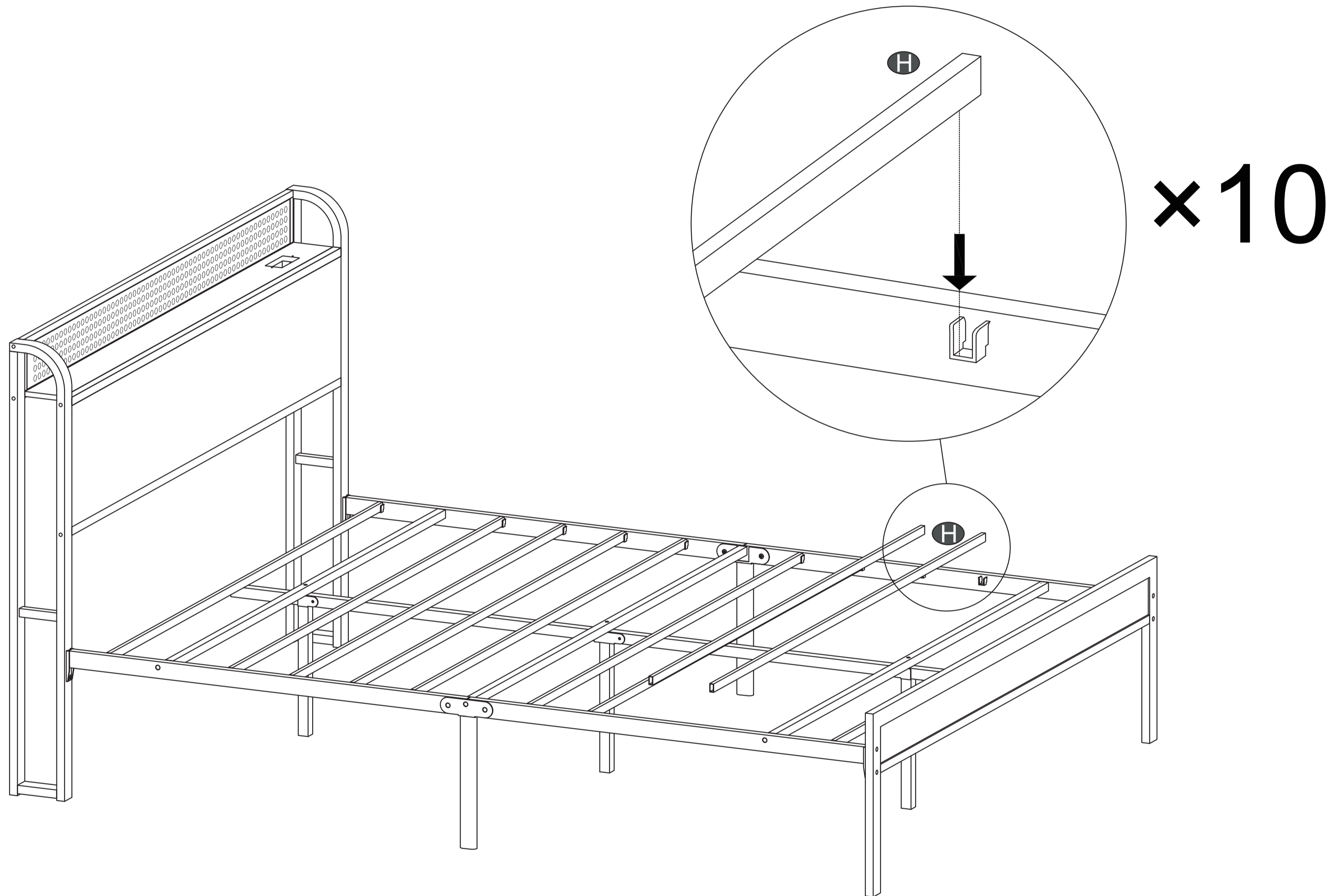

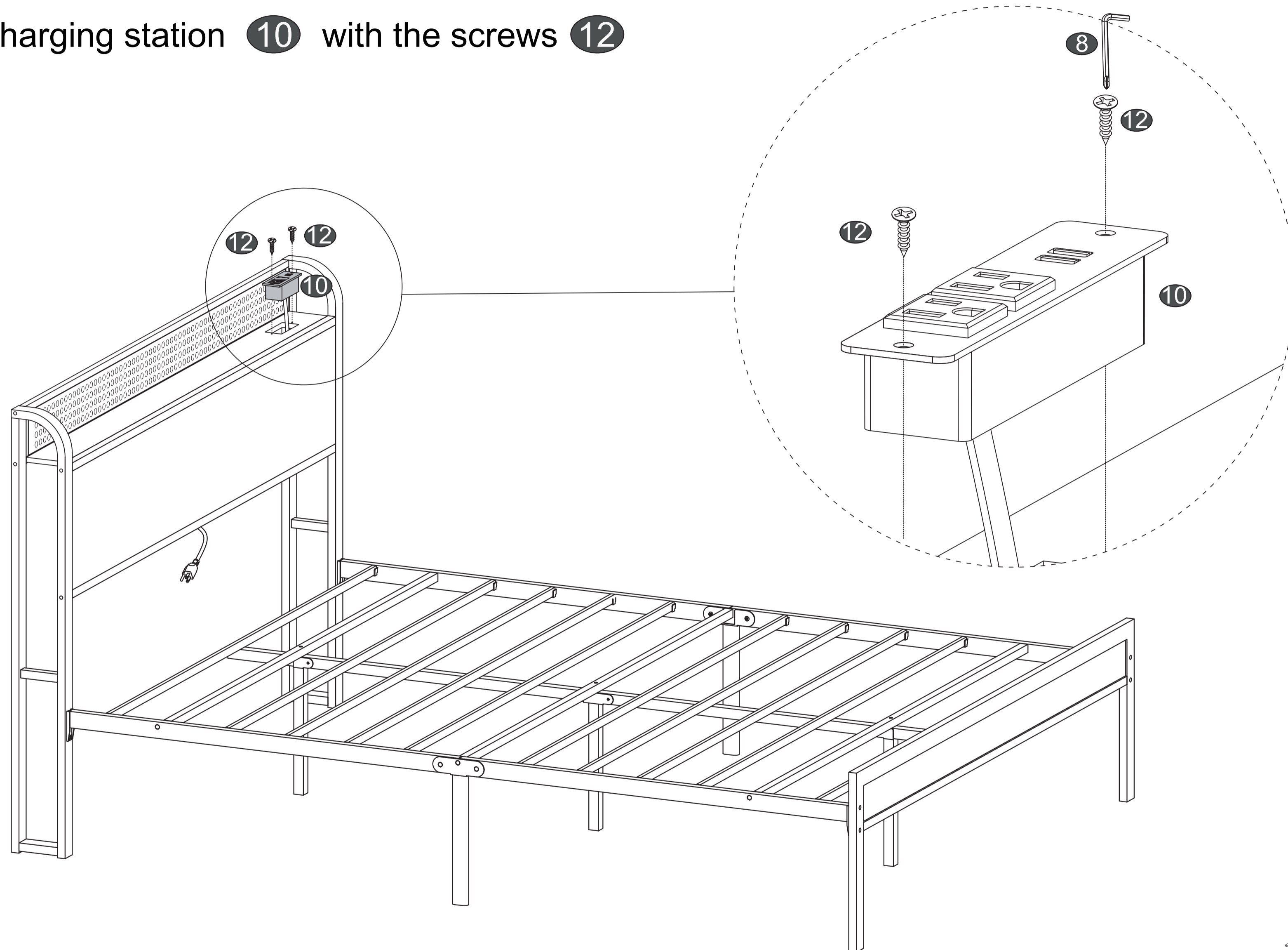

 **step 12**

Install the charging station **10** with the screws **12**

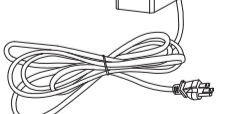

12

-  **8** × 1pc  **10** × 1pc  **12** × 2pcs

 **step 13**

Installing the light strip from the footboard to the headboard

Installing the light strip

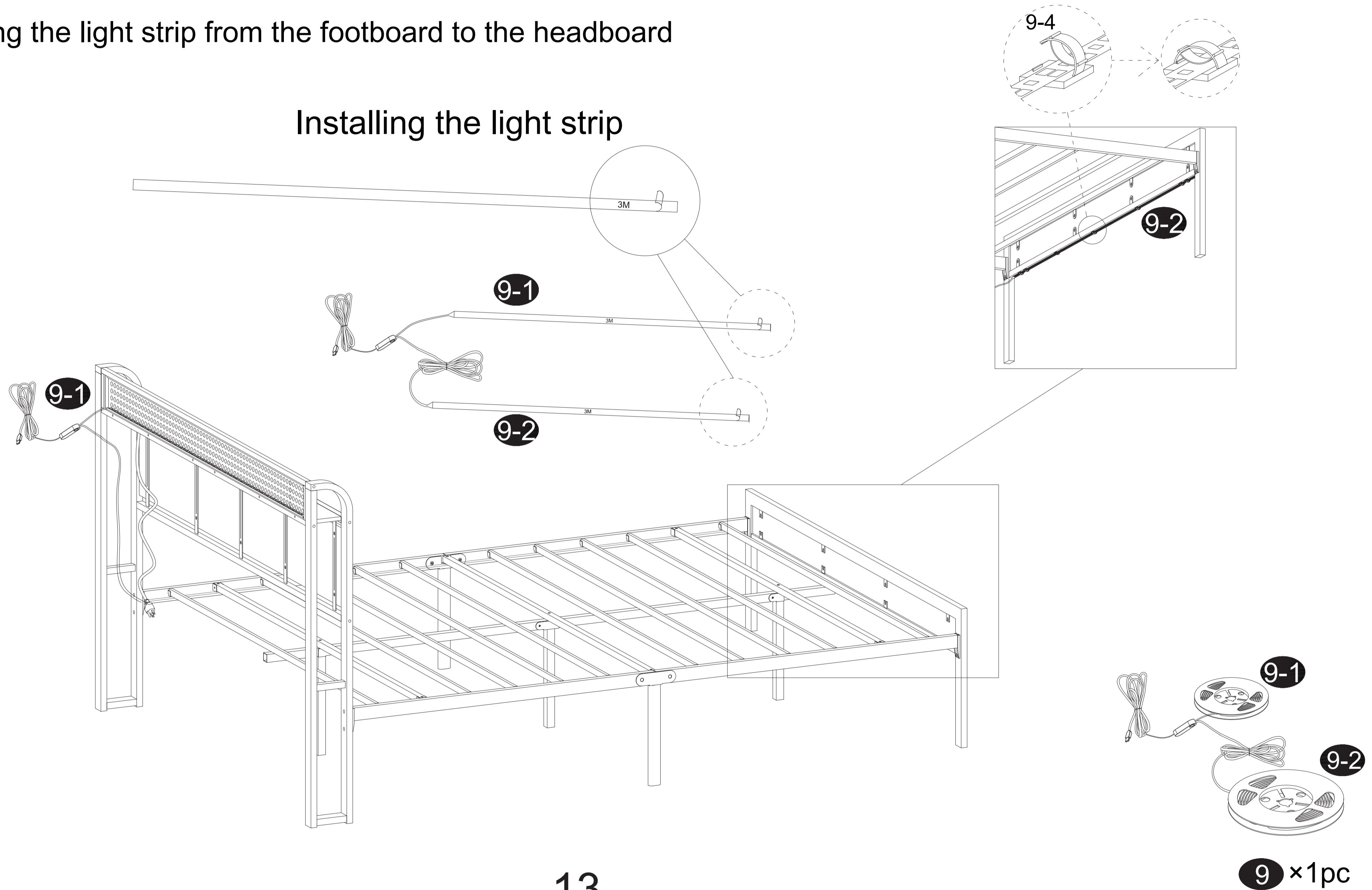

 **step 14**

Glue part **7** evenly to the edge of the bed before fixing the lamp strip inside.

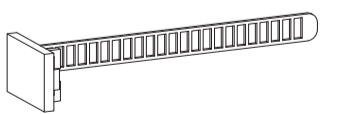
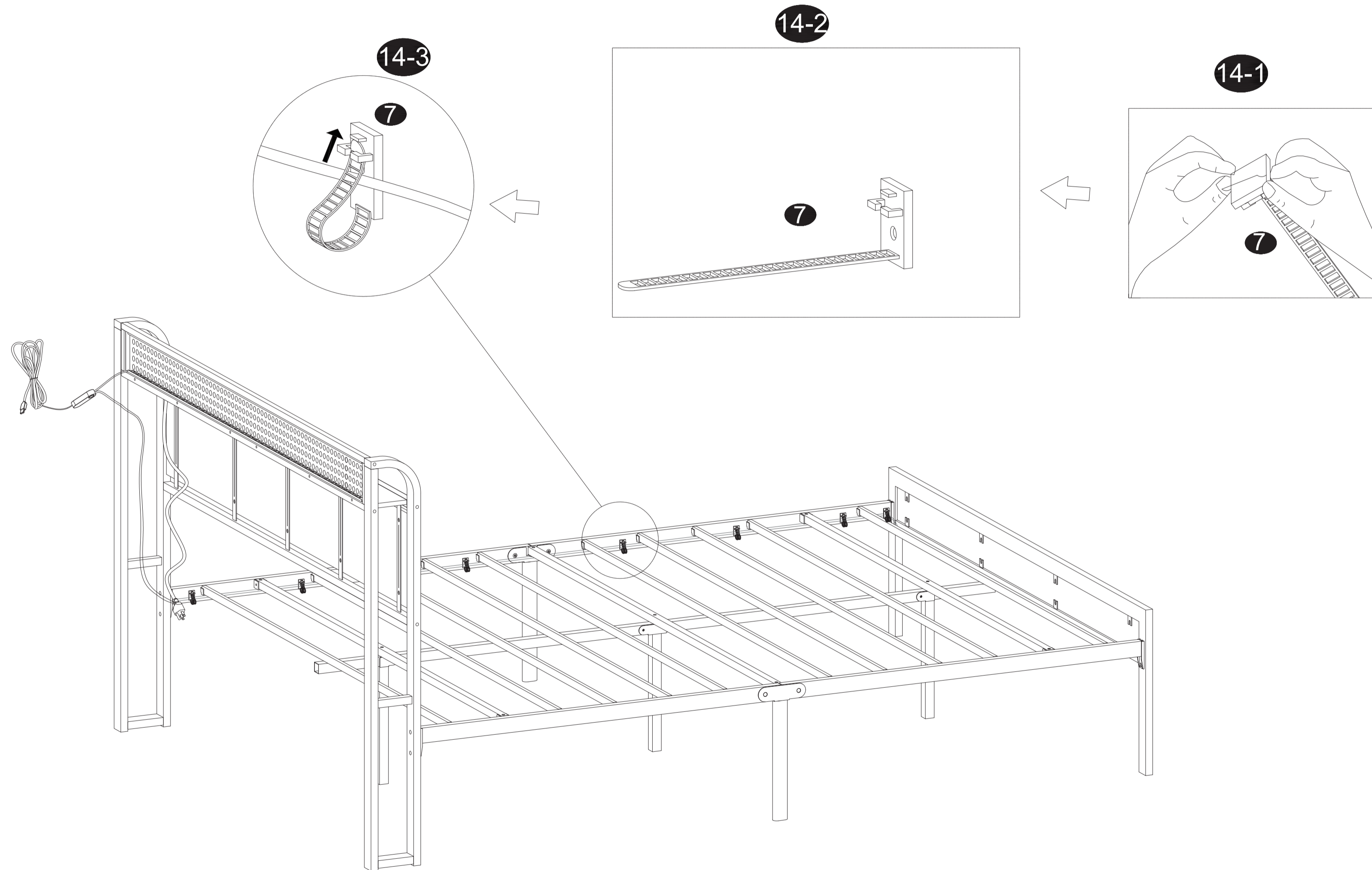

7 × 7 pcs

 **step 15**

Snap the mattress anti-slip clips **J** onto the bed frame's side rails.

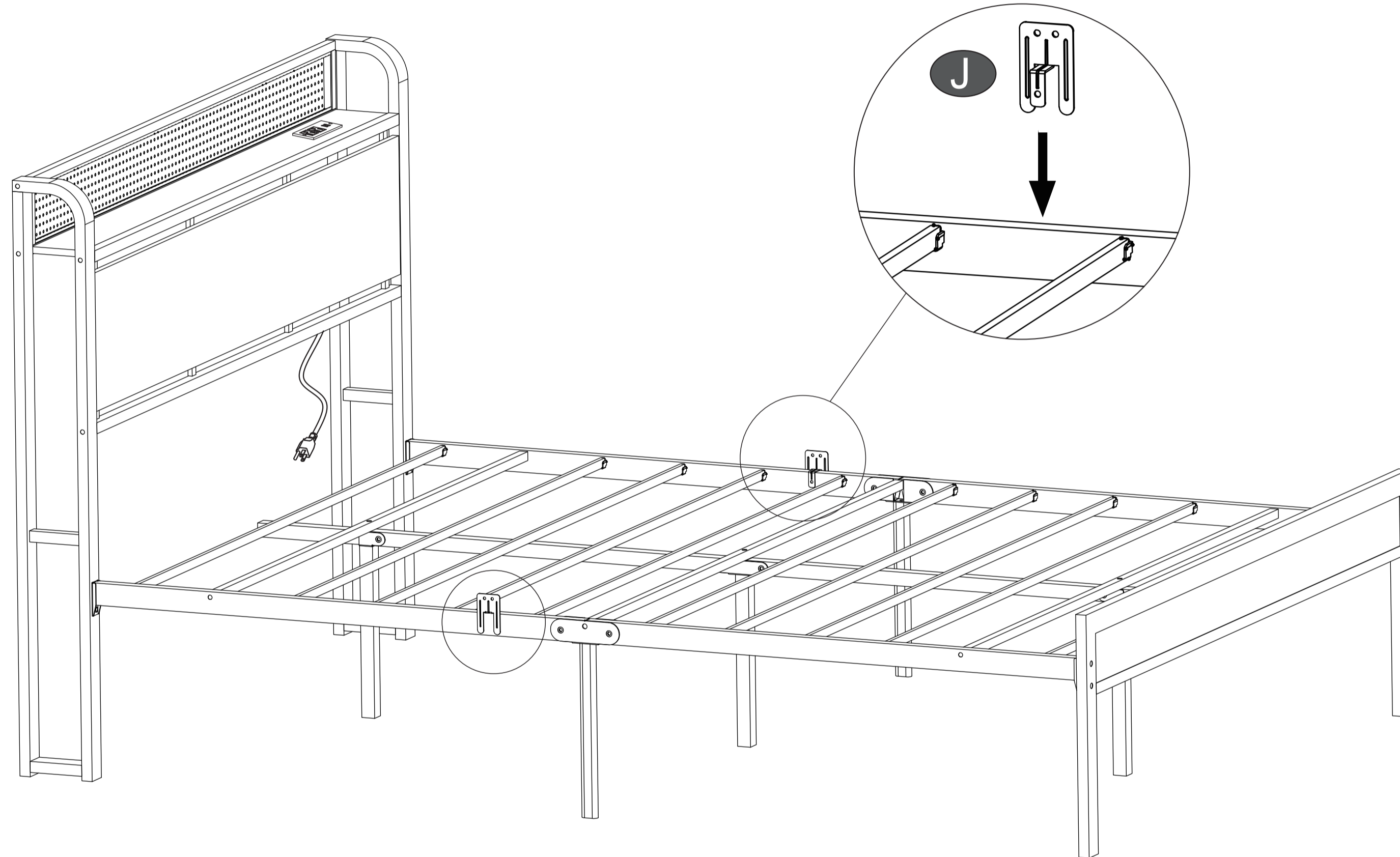

Remote Control

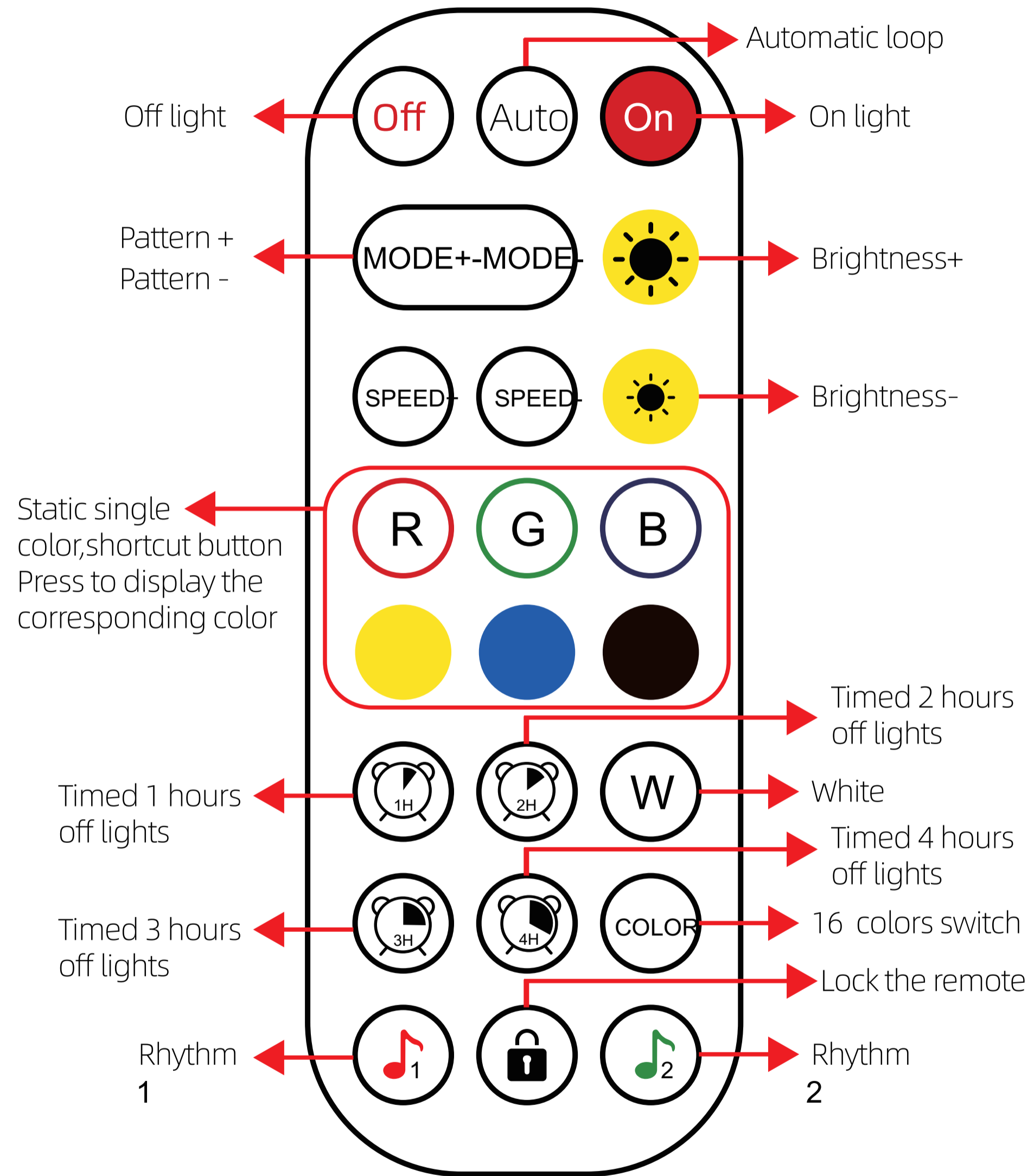

Customer Service

1-Year Warranty

We guarantee your product is free from defects in product material and workmanship for one(1)year starting from the date of purchase during normal use of household conditions. If your appliance fails within the limited warranty period, we will arrange a new replacement free of charge, and cover all the shipping costs.

Quick Response within 24 Hours

If you are still unable to resolve the issue you are experiencing, please contact us immediately at our support email.

It doesn't matter if the product has been installed, our customer support team will respond within 24 hours and assist you quickly and efficiently. The most efficient way to confirm your problem with us is to attach a video or picture illustrating your product issue.

Problems You May Encounter

PART	PROBLEM	SOLUTION
Whole Product	Parts are missing, defective or having wrong parts in package.	You can contact us, and we will get back to you within 24 hours.
	Encountering non-human caused damage during usage.	If the product is damaged due to non-human causes, please keep the product and send us photos of it. We will ascertain the cause of the product damage within 48 hours and provide you with a satisfactory solution.
Board Surface	Board Surface is broken, scratched or lack of some screw holes.	You can contact us, and we will get back to you within 24 hours.
	The screw holes that on the board and steel frame don't line up.	1. Please tighten the screws on the board by 70%, do not tighten completely. 2. Adjusting board and steel frame until the screw holes are lined up,then tighten all the screws.
	The wood board is uneven or not tight that has gaps after being assembled.	You can contact us, and we will get back to you within 24 hours.
Steel Frame	The steel frame is bent, broken, painted, rusted or damaged.	You can contact us, and we will get back to you within 24 hours.
	The bed frame is unstable after being assembled.	1.Check if the screws are tightened. 2. Read through out the manual, check are there any parts insalled incorrecly or missing assembled. 3. If your problem still can't be solved, please feel free to contact us.