

# MEDIUM STORAGE CABINET





**Questions, problems, assembly help, missing parts?**

No need to return the product, we will gladly help and ship your replacement parts free of charge

In order to assist you in a timely manner, please have the following information ready:

Model # \_\_\_\_\_ Part Number or Letter \_\_\_\_\_

Purchased at \_\_\_\_\_ Date of Purchase \_\_\_\_\_

**If you wish to return the product, please contact the retailer where the product was purchased.**

**IMPORTANT** : Please read this manual carefully before beginning assembly of this product. Keep this manual for future reference.

## **SAFETY INFORMATION**

**CAUTION:** Injuries and damage can occur from furniture tip over if product is not properly anchored to the wall. Use the Furniture Anti-Tipping Restraint provided with the product. Consult our assembly instructions for help.

If the Furniture Anti-Tipping Restraint kit is not in the box, please contact our customer service department in order to obtain another kit before using the furniture.

Identify all the parts and hardware. Do not discard of the packaging until you have checked that you have all of the parts and hardware required. Hardware package may have spare parts.

**WARNING:** This item contains small parts which can be swallowed by children and pets. Keep children and pets away during assembly. To avoid danger of suffocation, always keep plastic bags away from children and pets. We recommend that you assemble this unit on a carpeted floor to avoid scratches. If using power tools, set the tool to low torque to avoid damage.

**May require 2 people for ease of assembly.**

**IMPORTANT** : Keep this manual for future reference.

## **CARE and MAINTENANCE**

### **Wood Furniture Care**

Perhaps the greatest environmental damage to wood furniture comes from wide swings in relative humidity (RH) in our homes. Wood absorbs and desorbs water as relative humidity rises and falls, and in doing so it swells and shrinks. Making matters worse, it expands and contracts unequally along different grain directions. As humidity changes, the components of wooden objects are continually pushing and pulling against each other. This pressure often results in parts of furniture no longer fitting together closely or becoming distorted or breaking from their own internal stresses.

The response to relative humidity changes begins with determining the annual average RH for your particular space. Then try to keep the RH in the space where your furniture is as close to that average as possible, generally within about 10% up or down. De-humidify in the summer and humidify in the winter.

Be aware that raising the temperature lowers the humidity and vice versa. Thus, modern heating systems, which can drive down interior RH in the winter, almost invariably cause problems for furniture. To counteract their effect, you can either modify the RH by keeping furniture containing spaces cooler in the winter or most importantly, have a good working humidifier for your home. A humidistat automatically works to balance the humidity in your home so it is constant. Dry indoor air can suck enough moisture from its surroundings to do permanent damage to wood, causing it to crack or split.

Remember, that not all woods are created equal. Two factors that help determine how rapidly a wood will lose moisture are pore size and surface hardness. A piece made from a dense and hard wood will dry less rapidly than pieces made from softer woods.

Furniture that is sealed and lacquered will lose moisture more slowly than an unfinished piece while pieces with veneer finishes are not only stronger, but lose moisture more slowly than other finishes.

#### **To help protect your wood furniture, take these steps:**

- Use a humidifier, preferably one with an automatic control system that can sense the humidity level and adjust itself accordingly. Don't over-humidify; that can damage wood by causing it to expand and contract.
- Keep furniture out of direct sunlight, which can cause it to dry out, crack and warp.
- If you can avoid it, don't put furniture near heating vents. If you must, keep the piece 3 to 4 inches away from the wall, giving the heat and air space to circulate.
- Dust with soft dry cloth.
- Do not use liquid or aerosol products.
- To avoid marking, do not place rubber ON SURFACE (FOOT PADS, ETC)
- For soil build-up, wipe with damp cloth & dry.
- Do not use abrasive cleaner.

# PRE-ASSEMBLY INFORMATION

## PARTS DESCRIPTION

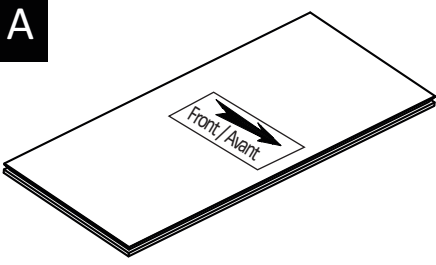

TOP  
QTY 1

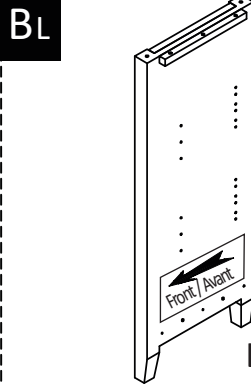

LEFT SIDE  
QTY 1

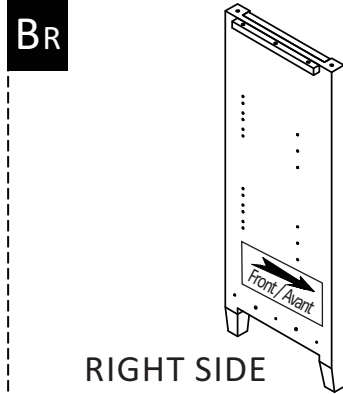

RIGHT SIDE  
QTY 1

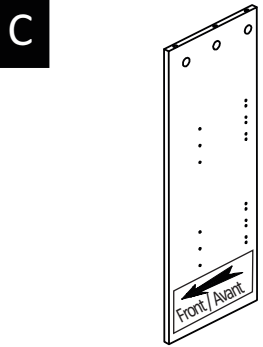

CENTRE SUPPORT  
QTY 1

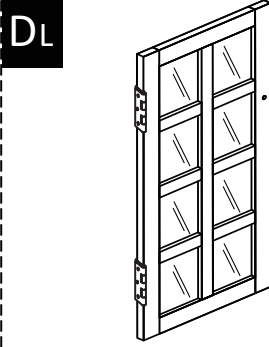

LEFT DOOR  
QTY 1

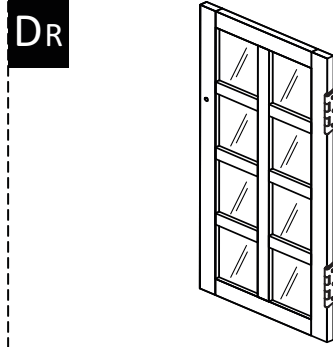

RIGHT DOOR  
QTY 1

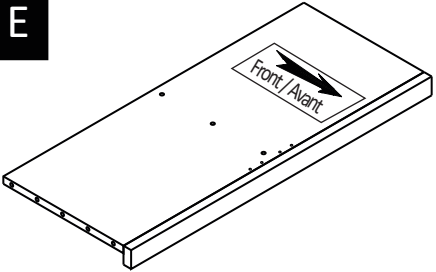

BOTTOM SHELF  
QTY 1

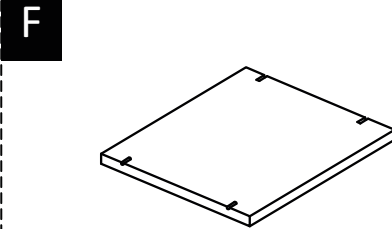

CABINET SHELF  
QTY 4

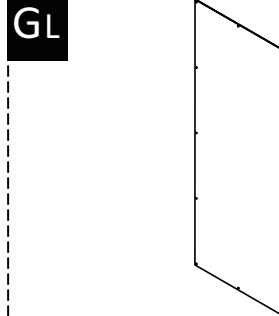

LEFT BACK PANEL  
QTY 1

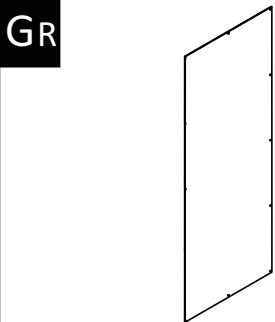

RIGHT BACK PANEL  
QTY 1

**NEED HELP?** For help with assembly or if you are missing a part, Please call customer service

# PRE-ASSEMBLY INFORMATION

## HARDWARE DESCRIPTION

1

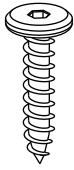

ALLEN KEY SCREW  
M6 X 30 mm  
QTY 9

2

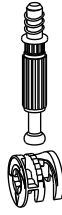

CAM LOCK PIN  
CAM LOCK  
QTY 9 SETS

3



ALLEN KEY  
QTY 1

4

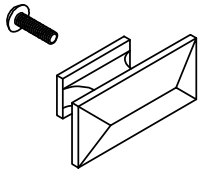

HANDLE  
M4 X 30 mm  
QTY 2 SET

5

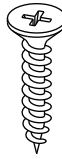

PHILLIPS SCREW  
M3 X 12 mm  
QTY 12

6

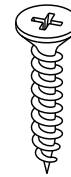

PHILLIPS SCREW  
M3 X 15 mm  
QTY 8

7

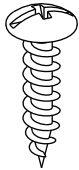

PHILLIPS SCREW ROUND HEAD  
M4 X 15 mm  
QTY 23

8

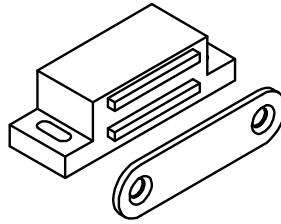

MAGNET AND PLATE  
QTY 2 SETS

9

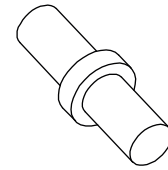

SHELF SUPPORT  
QTY 24

10

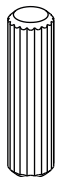

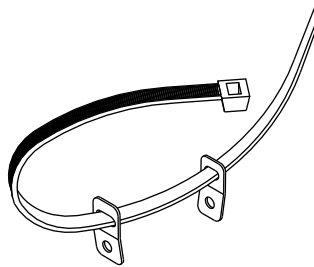

WOOD DOWEL  
Ø8 X 30 mm  
QTY 4

11



FURNITURE TIP OVER RESTRAINT  
QTY 1 SET

- a.  M4 X 25 - QTY 2  
( 1 is extra )
- b.  M4 X 15 - QTY 1
- c.  M4 X 25 - QTY 1

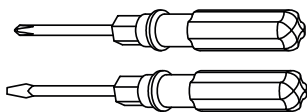

Required -  
Flathead screwdriver  
Phillips screwdriver  
Rubber mallet  
**Not Included**

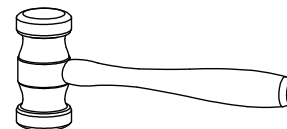

**NEED HELP?** For help with assembly or if you are missing a part, Please call customer service

# COMPONENTS – KEY DIAGRAM

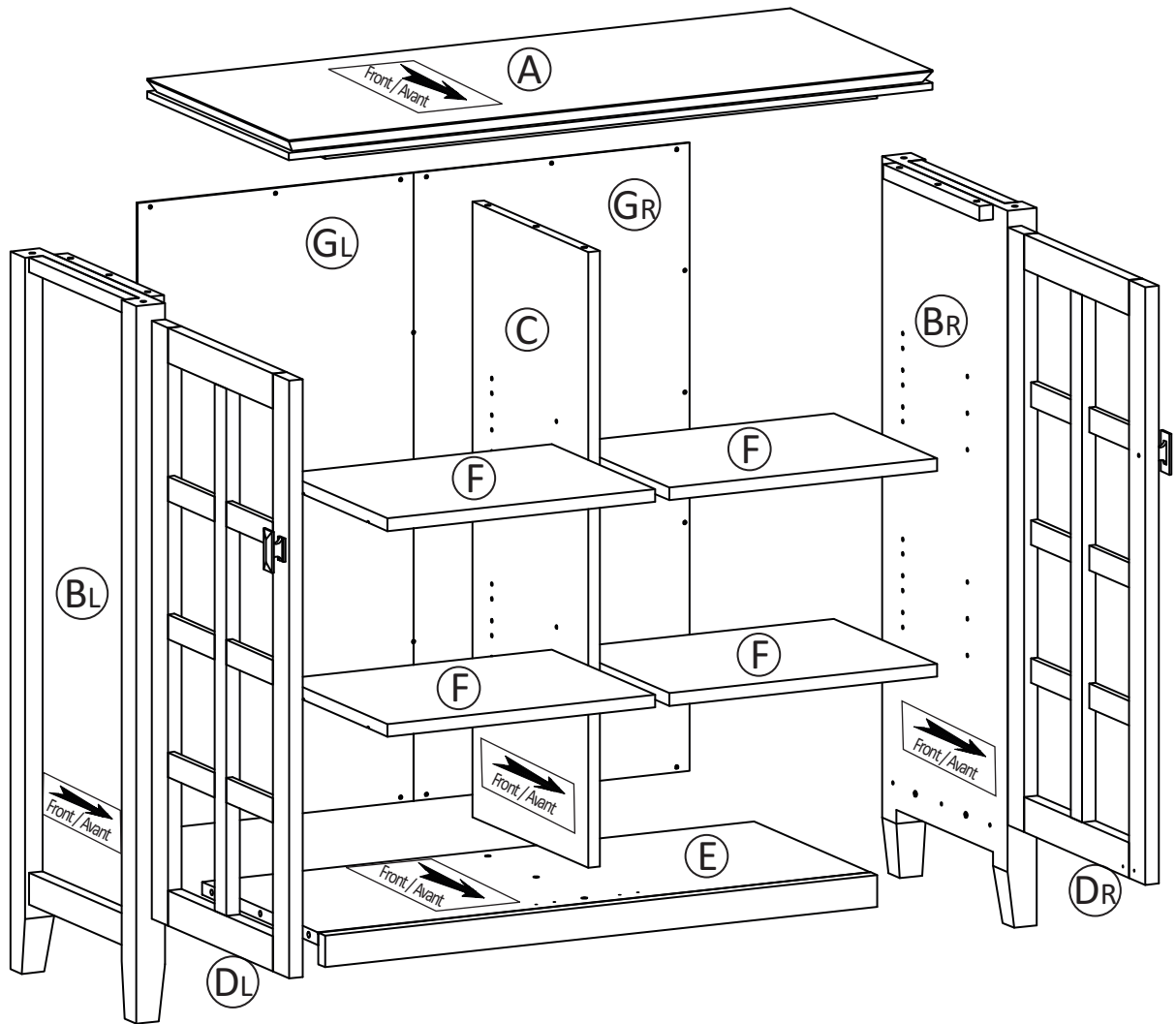

# ASSEMBLY

## STEP 1

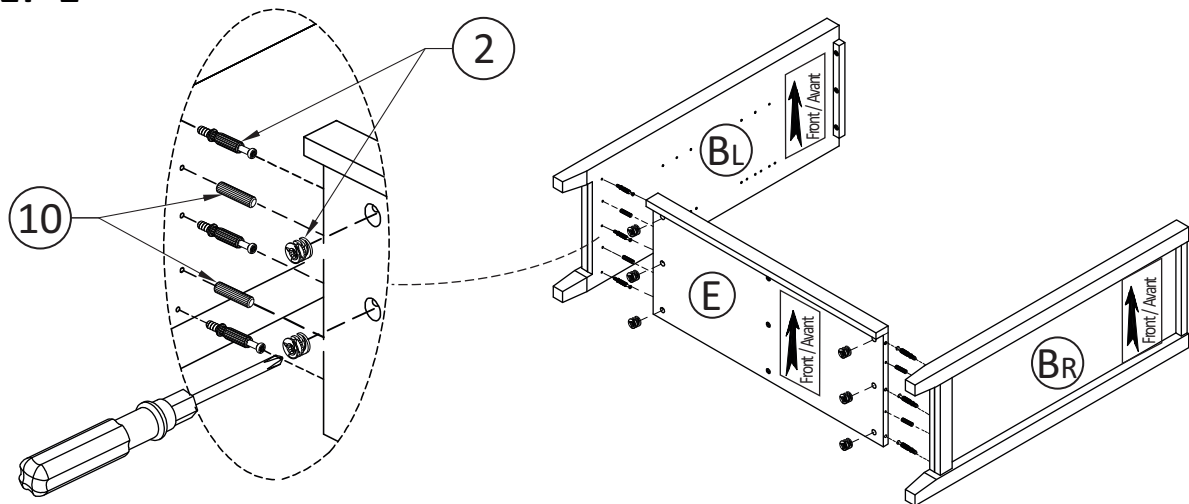

1. Insert Wood dowels (10) into pre-drilled holes on Bottom Shelf (E).
2. Use rubber mallet to tap Dowels (10) into bottom of holes securely. 1/2 length of Dowels should be exposed.
3. Attach Cam Lock Pins (2) to Sides (BL), (BR) using guide holes.
4. Align Cam Lock Pins (2) into pre-drilled holes on Bottom Shelf (E).
5. Insert Cam Locks (2) into pre-drilled holes on Bottom Shelf (E).
6. Once in place tighten Cam locks (2) using a flathead screwdriver.

## STEP 2

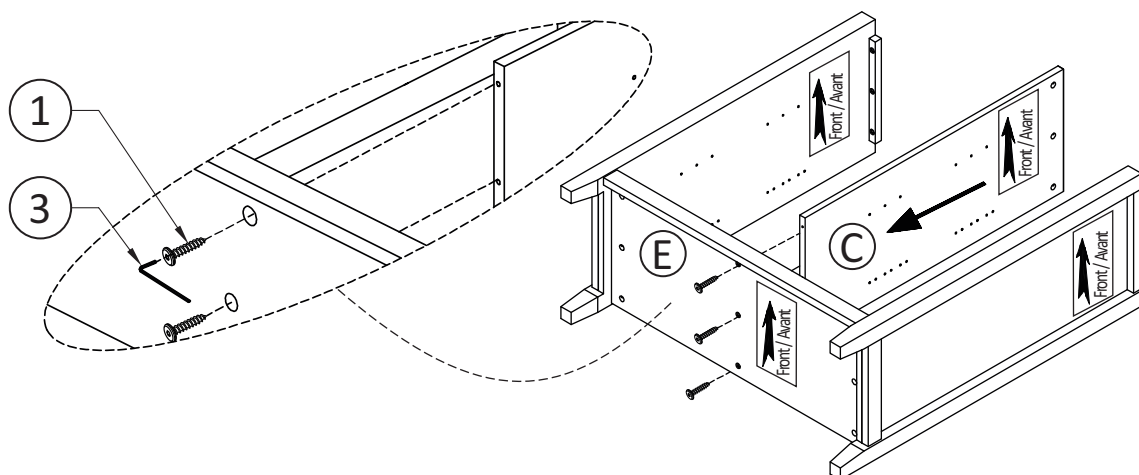

1. Attach Centre Support (C) to Bottom Shelf (E) with Allen Key Screws (1) through pre-drilled holes.

# ASSEMBLY

## STEP 3

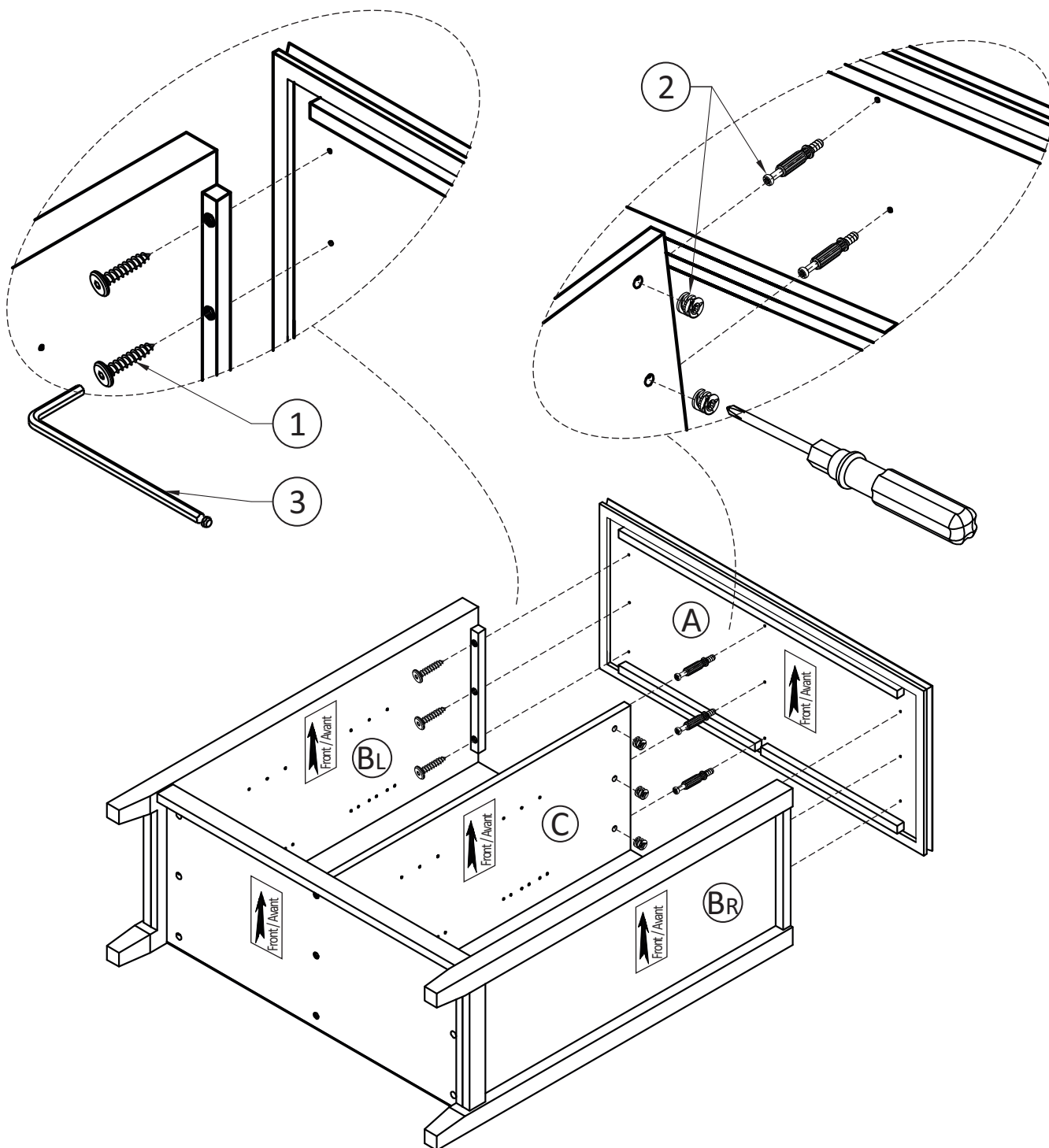

1. Attach Cam Lock Pins (2) into middle underneath of Top (A) using guide holes.
2. Align pre-drilled holes on bottom of Top (A) with pre-drilled holes on Sides (BL), (BR) and insert Cam Lock Pins (2) into pre-drilled holes in Centre Support (C).
3. Fix Top (A) to Sides (BL), (BR) using Allen Key Screws (1). Use Allen Key (3) to tighten Screws. Do not over-tighten.
4. Fix Top (A) to Centre Support (C) using a flathead screwdriver tighten Cam Locks (2). Do not over-tighten.

# ASSEMBLY

## STEP 4

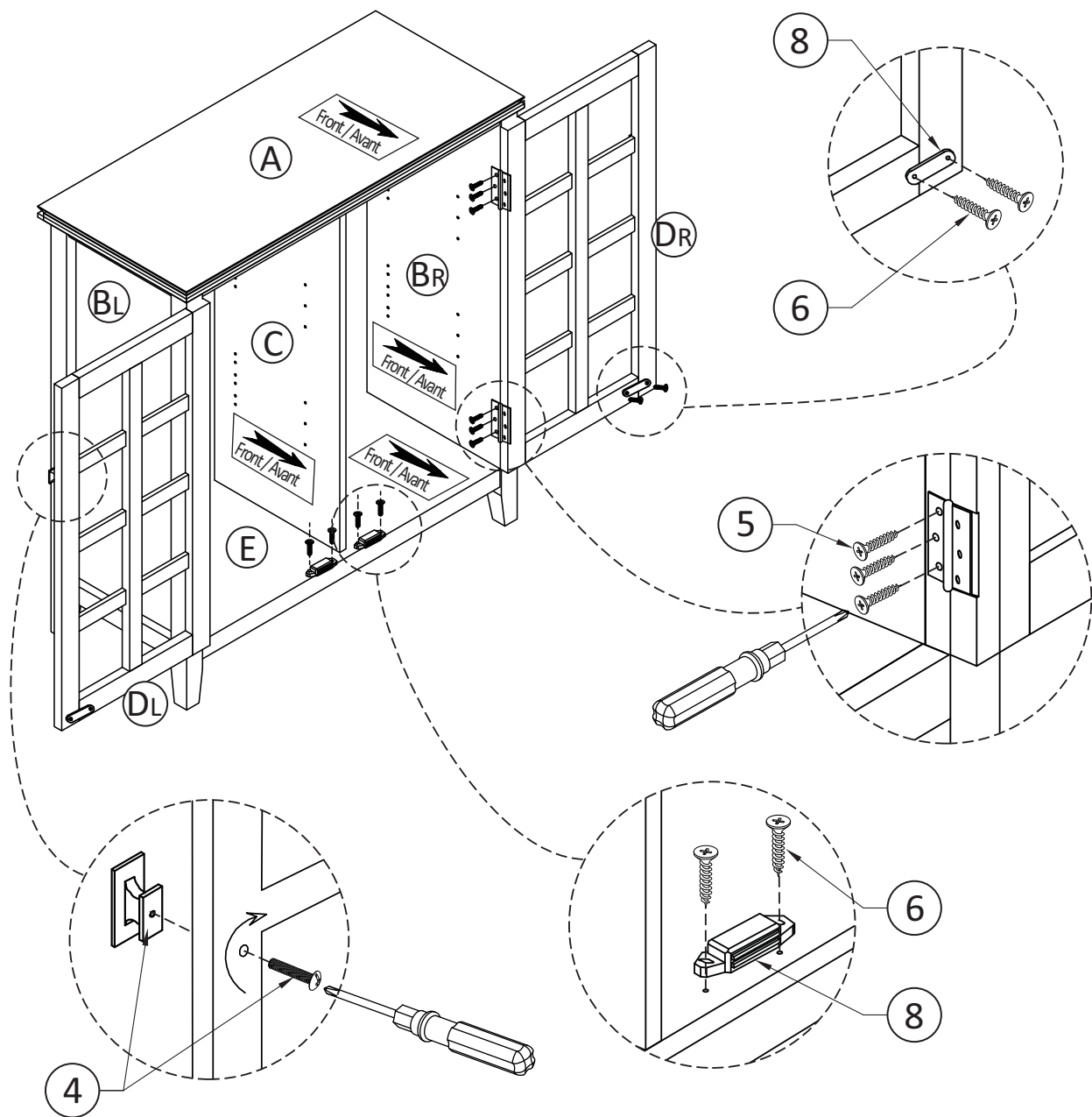

1. Attach hinges on Doors (DL), (DR) to Sides (BL), (BR) using Phillips Long Screws (5).
2. Attach Magnet Plates (8) to bottom corner of Doors (DL), (DR) using Phillips Short Screws (6) into guide holes on Doors (DL), (DR).
3. Attach Magnet (8) using Phillips Screws (6) into guide holes on Bottom Shelf (E).
4. Use a Phillips screwdriver to attach Handles (4) to Doors (DL), (DR).

# ASSEMBLY

## STEP 5

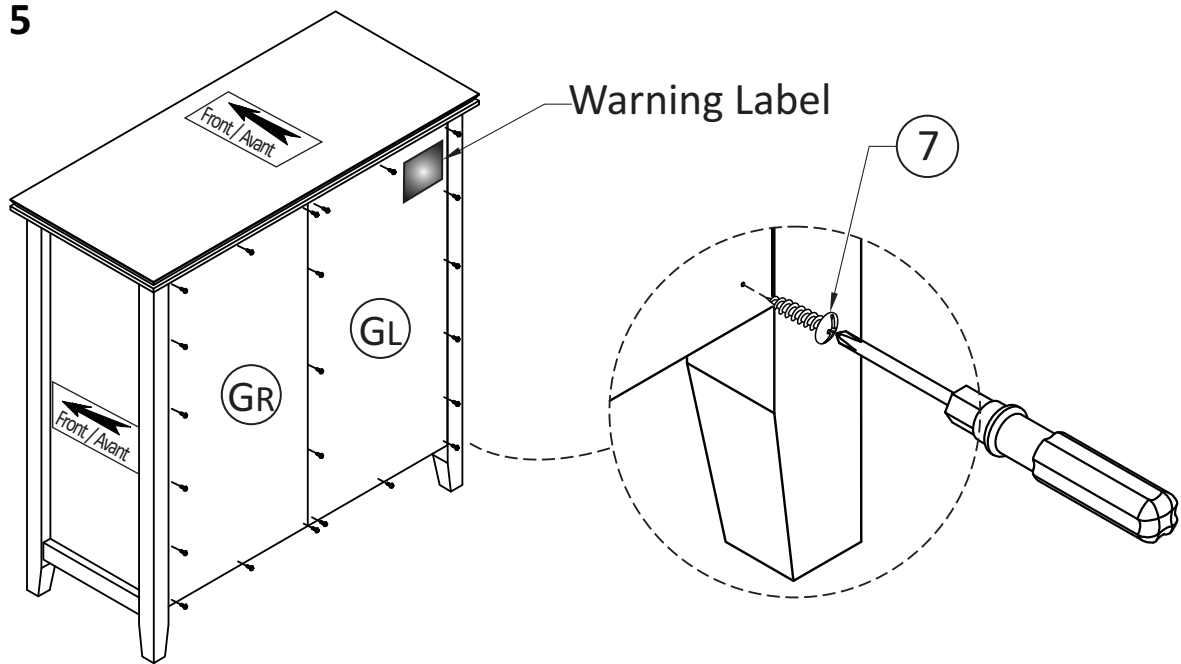

1. Attach Back Panels (GL), (GR) to back of cabinet using Phillips Screws Round Head (7) into pre-drilled guide holes.
2. Use Phillips screwdriver to tighten screws.

## STEP 6

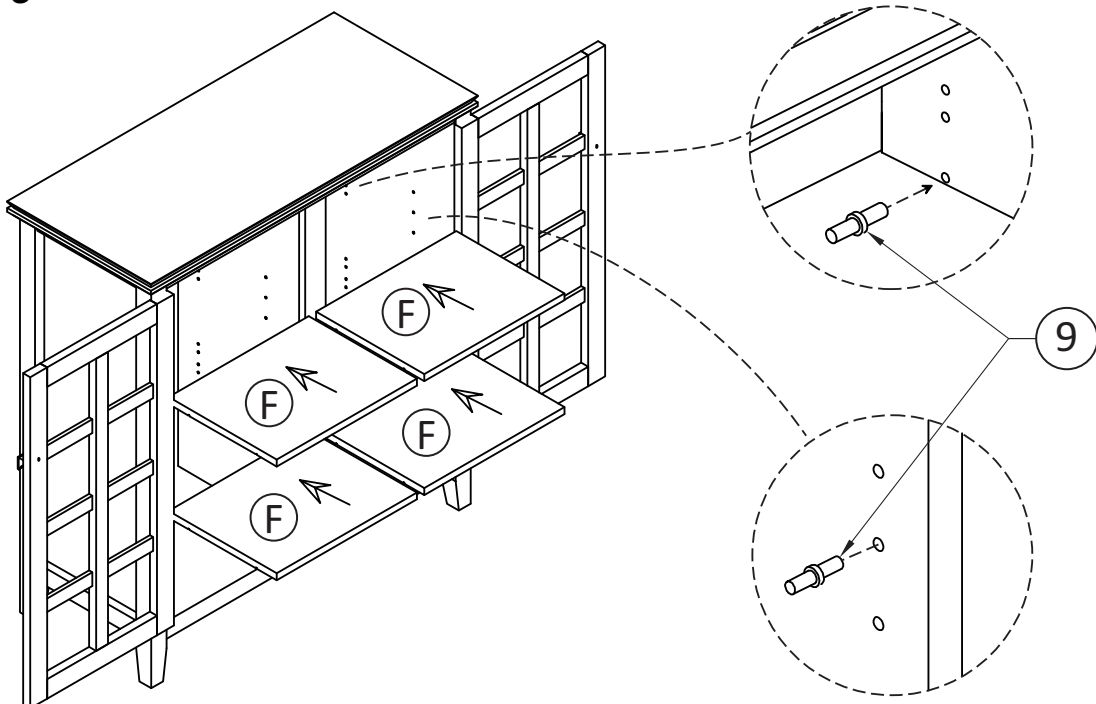

1. Use 4 Shelf Supports (9) for each Cabinet Shelf (F) in desired location.
2. 2 Shelf Supports (9) may be used on back top of each Cabinet Shelf (F) as a tipping restraint.

## FURNITURE TIP OVER RESTRAINT ASSEMBLY

### **WARNING**

Serious or fatal crushing injuries can occur from furniture tip-over.  
If the furniture tip over restraint kit is not in the box, please contact our customer service department in order to obtain another kit before using the furniture.

### STEP 7

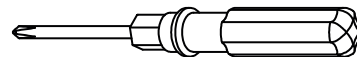

**NOTE:** The screwdriver is not included in the hardware pack.

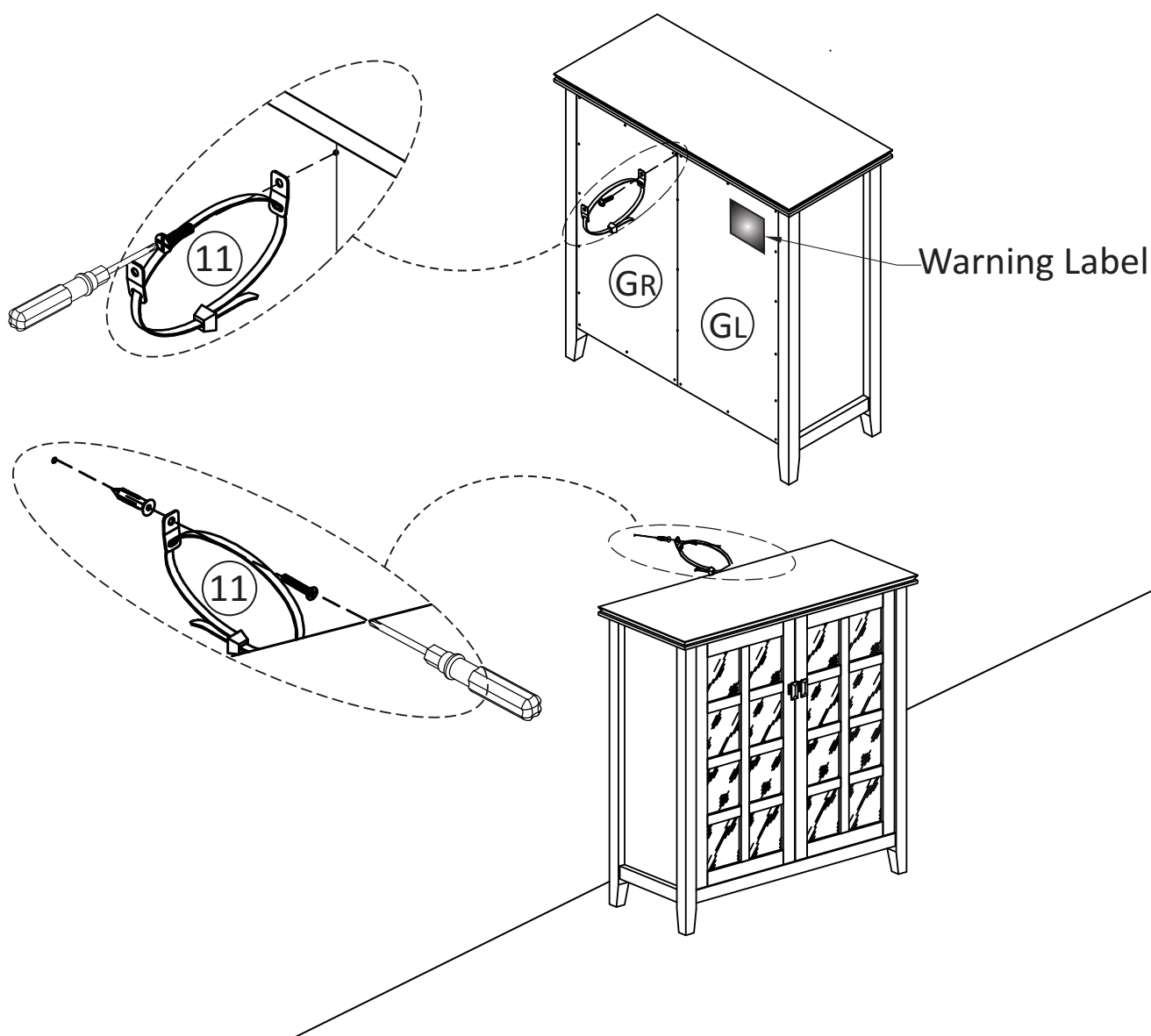

## FURNITURE TIP OVER RESTRAINT ASSEMBLY

### Furniture Tip Over Restraint Instructions:

1. Attach one of the mounting brackets securely to the back edge of the furniture. Use the shorter screw.

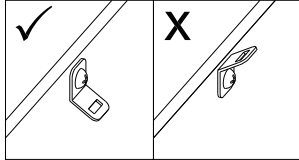

2. Determine where furniture is to be placed and mark location on the wall for mounting bracket screw hole approximately 2 inches **below** the bracket mounted to the furniture.

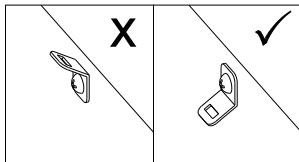

3. Drill a 3/16 inch hole in the wall. Press the plastic anchor into the hole and gently tap until the flange on the anchor is against the wall surface.
4. Position the bracket over the anchor and use the longer screw to securely attach the bracket to the wall.
5. Place the furniture so the back edge is in line with the bracket on the wall.
6. Lace an end of the nylon zip-tie strap down through each bracket. Bring both ends together and slide the smooth side upright through the square-shaped end and pull through to create the "locked" position.
7. Check to make sure the strap is securely laced and locked to the brackets.

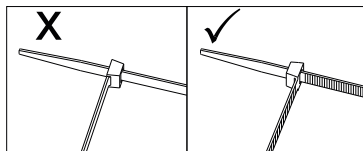

- **DO NOT** put a TV or other heavy objects on top of a Storage Cabinet or any other furniture not intended for use with a TV
- **DO NOT** place heavy objects in top drawers
- **DO NOT** let children climb or hang on drawers, doors or shelves

## WARRANTY

Thank you for purchasing product. These products have been made to demanding, high-quality standards and are guaranteed for domestic use against manufacturing faults for a period of 12 months from the date of purchase. This warranty does not affect your statutory rights.

In case of any malfunction of your product (failure, missing parts, etc.) please contact us at our toll free service line or by email.

We reserve the right to repair or replace the defective product, at its discretion.

This product is guaranteed for 12 months if used for normal purposes. Any warranty is invalid if the product has been overloaded or subject to neglect, improper use or an attempted repair by other than an authorized agent. Heavy-duty or daily professional/commercial usage are not guaranteed.

Due to continuous product improvement, we reserve the right to change the product specifications without prior notice.