

ASSEMBLY INSTRUCTIONS

426-313/314/R52

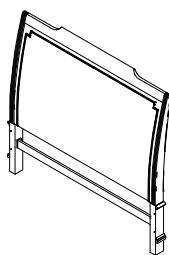

426-313

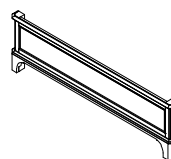

426-314

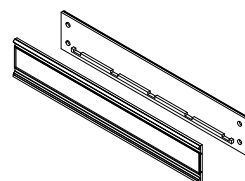

426-R52

TOOLS REQUIRED:

Spanner wrench (supplied, part # C)
Phillips Head Screwdriver (Not Provided)

BEFORE YOU START:

1. Check the parts against the parts list to make sure all items are present.
2. Assemble your furniture on a soft, flat surface to avoid scratching the finish.
3. **CAUTION:** Do not over tighten screws, nuts or bolts during assembly.
4. Your furniture may require occasional tightening.

INSTRUCTIONS:

NOTE: The assembly of the rails to the Headboard & Footboard are the same for all styles of beds.

1. Screw the Thread Bolt (B) into the threaded insert of the Headboard post.

2. Then slide bed rail over the bolts until they are visible in the holes on the inside of the rails. Attach bed rail to the Headboard post by using Hexagonal Nuts + Curved Washers (A) and tighten all nuts with Spanner Wrench (C).

3. Repeat the same for the Footboard. (See Figure 1)

4. Insert Bolt on each Support Leg into pre-drilled holes in center of Slat, tighten by turning the Support Legs in clockwise. (See Figure 2).

Lay assembled Slats with support legs on the cut-outs of bed rail's cleats. Secure Wood Screw (D) through pre-drilled holes on ends of Slats with a Phillips head screw driver (not provided). (See Figure 3).

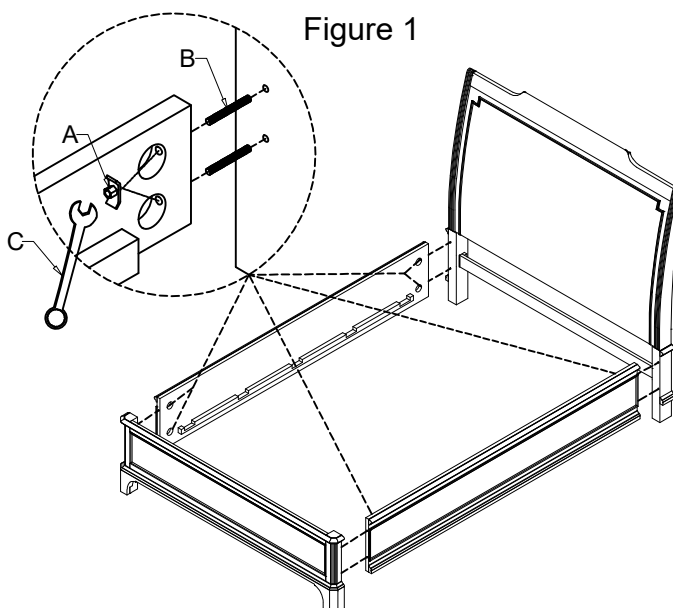

Figure 1

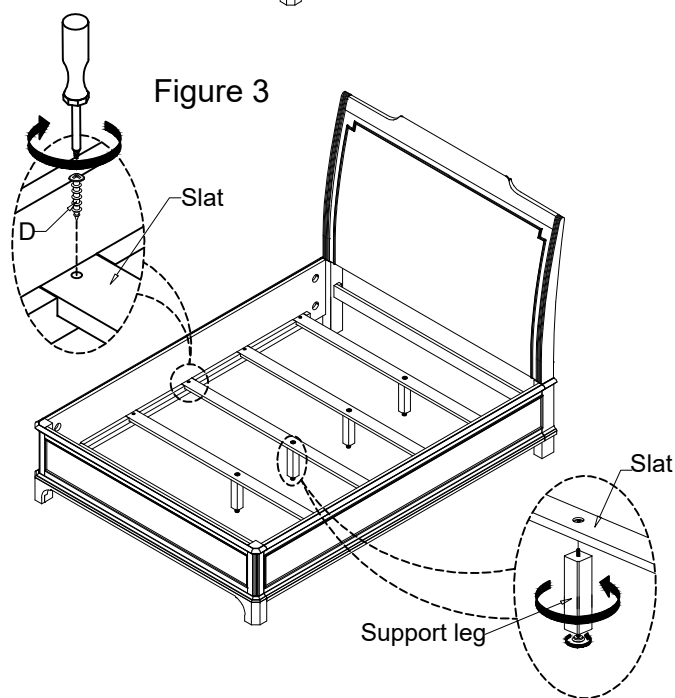

Figure 2

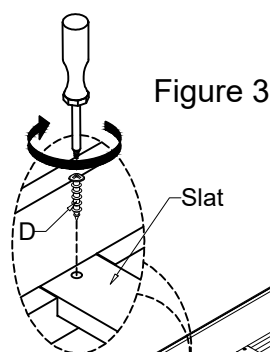

Figure 3

No.	Hardware List		Q'ty
A		Hex Nut Ø5/16" + Curved Washer Ø5/16"	8
B		Thread Bolt Ø5/16"xL3-1/4"	8
C		Spanner Wrench D12mm	1
D		Screw Ø8xL1-1/4"	10