







ASSEMBLY INSTRUCTIONS

| PARTS LIST | | | | HARDWARE LIST | | | |
|------------|-----------------------------|---|-----|---------------|-----------------------------|---|-----|
| NO | DESCRIPTION | | QTY | NO | DESCRIPTION | | QTY |
| 1 | LEFT LEG FRAME |  | 1 | A | ALLEN WRENCH |  | 1 |
| 2 | RIGHT LEG FRAME |  | 1 | B | JCBC SCREW 1/4"xØ13x50mm |  | 12 |
| 3 | BACK REST |  | 1 | | | | |
| 4 | FRONT CROSS BAR FOR SEAT |  | 1 | | | | |
| 5 | BACK CROSS BAR FOR SEAT |  | 1 | | | | |
| 6 | CROSS BAR |  | 1 | | | | |
| 7 | CHAIR SEAT |  | 1 | | | | |

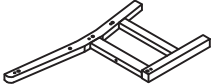
Step 1:

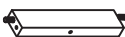
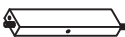
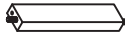
Align the left leg frame (1) and the right leg frame (2) to back rest (3) front cross bar for seat (4), back cross bar for seat (5) and cross bar (6) as shown.

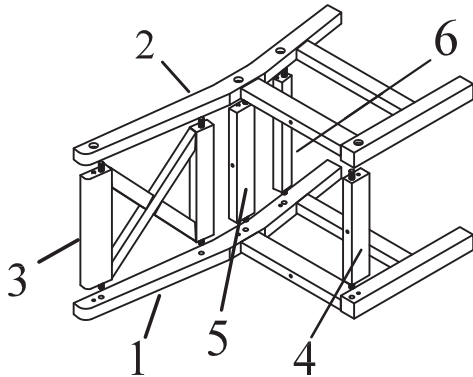

Step 2:

- Insert JCBC screw (B) into each hole on left leg frame (1) Use Allen wrench (A) loosely tighten JCBC screw (B) as shown.
- Turn the chair and insert JCBC screw (B) into each hole on right leg frame (2). Use Allen wrench (A) loosely tighten JCBC screw (B) as shown.

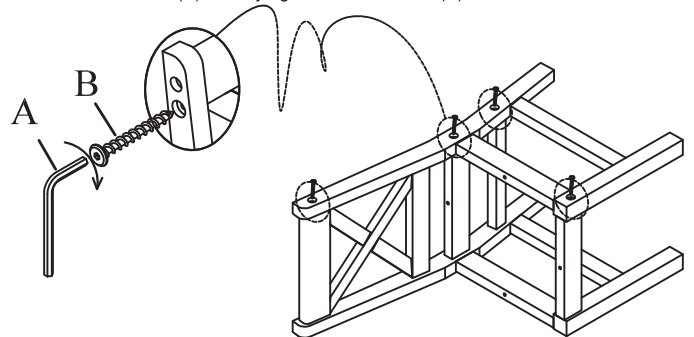

Step 3:

Place the chair seat (7) back side up on a flat table top protected with soft cloth or cardboard. Turn and attach assembled unit from step 2 to the chair seat (7) inserting JCBC screw (B) and tighten with Allen wrench (A) as shown.

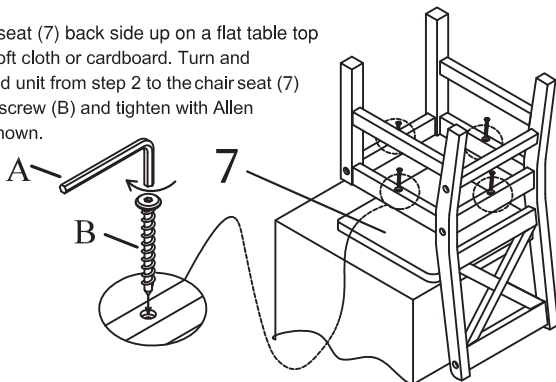

Step 4: Please tighten all screws and then the chair is ready to use.

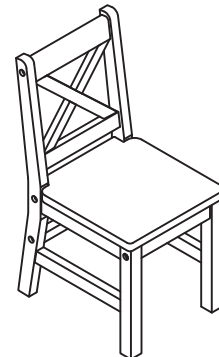

IMPORTANT NOTE:

- *** PLACE ALL WOODEN PARTS ON A CLEAN AND SMOOTH SURFACE SUCH AS A RUG OR CARPET TO AVOID SCRATCHING THE PARTS.
- *** KINDLY FOLLOW THE ASSEMBLY INSTRUCTION STEP BY STEP.
- *** WE RECOMMEND THAT YOU SAVE THE ALLEN WRENCH (PART A) AND PERIODICALLY TIGHTEN ALL BOLTS/SCREWS. PLEASE MAKE SURE ALL BOLTS/SCREWS ARE PLACED IN THEIR PROPER POSITION AND ARE TIGHTENED SECURELY TO ENSURE YOUR SAFETY
- *** DO NOT STAND OR CLIMB ON THE CHAIR.
- *** WEIGHT RESTRICTION: 100LBS.
- *** NOT FOR COMMERCIAL USE.