

NOTE:

This brochure contains IMPORTANT safety info. Please read and keep for future reference.

MAINTAINANCE AND WARNING

- 1.Keep furniture away from heat sources.
- 2.Do not clean furniture with harsh cleaner or polishes.Do not use detergents,solvents,abrasives,spray packs or leather cleaner. Use non-color mild soa with warm water to clean spills(Mix 1:10 soap to water).
- 3.Do not place furniture under direct sunlight,material will possibly fade over time.
- 4.Do not use on site dry cleaning machine.Children should not climb or jump on the furniture.
- 5.Do not write on furniture that is not protectedby a padded barrier.
- 6.Not for commercial use,only for residential use.

WARRANTY

- 1.We strive to offer high-quality products,and we also try our best to satisfy each and every customer that orders from us with product or service as needed.
- 2.We provide 30 days warranty starting from the time you receive the item.Each customer must provide a record of their order such as the order number,or item receipt for any items that are out of the warranty period you may also still receive.
- 3.Replacement parts by purchasing them with our company if they are available.



ASSEMBLY INSTRUCTIONS

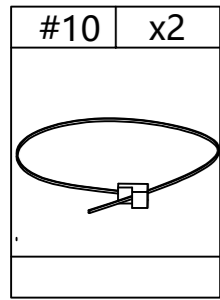

STEP-16

1. Let the plastic belt #10 pass through the both part #13 and pull tightly.

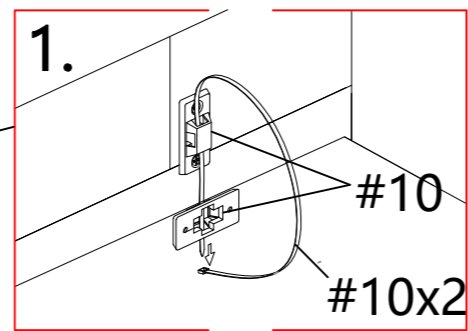
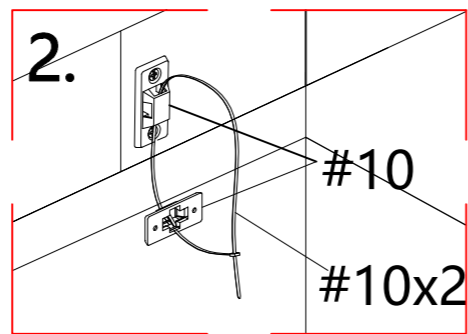
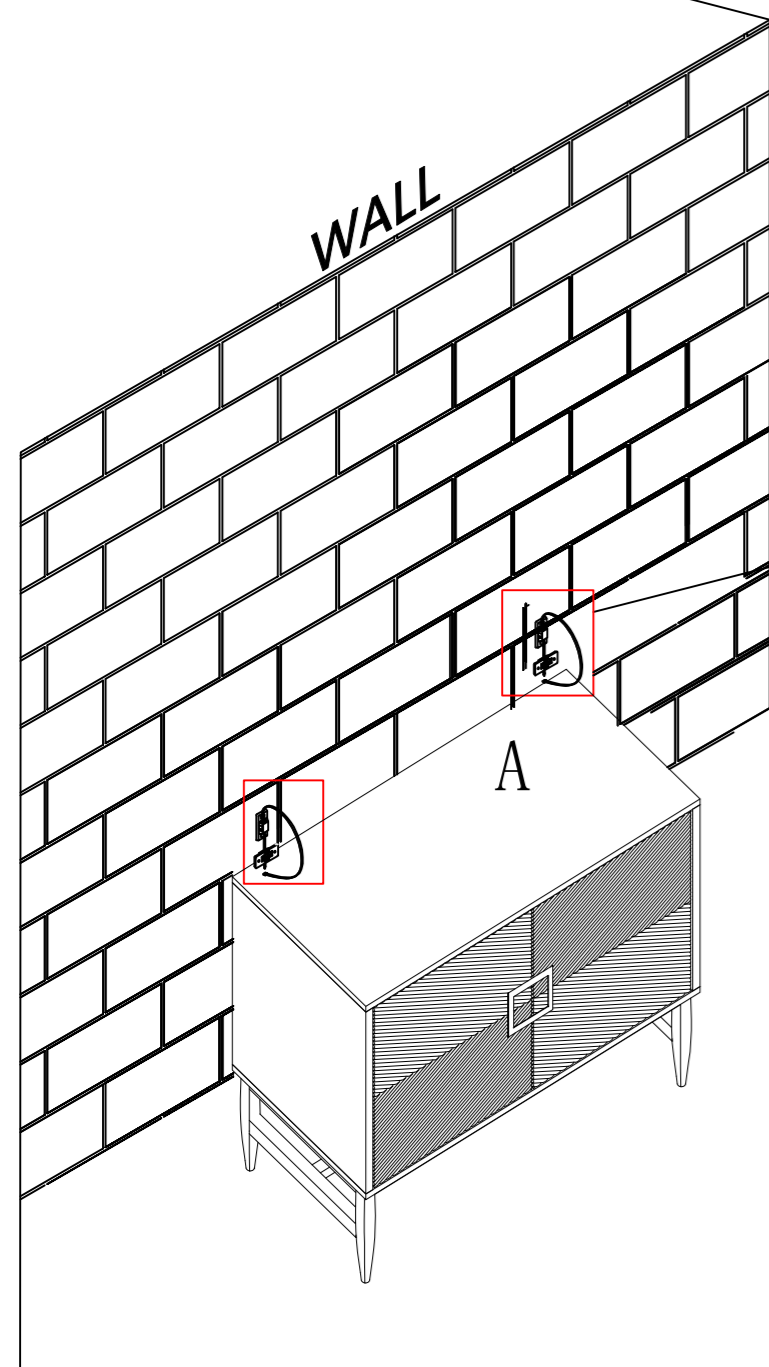

EXPLOSIVE VIEW

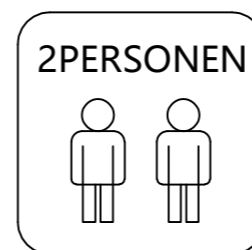
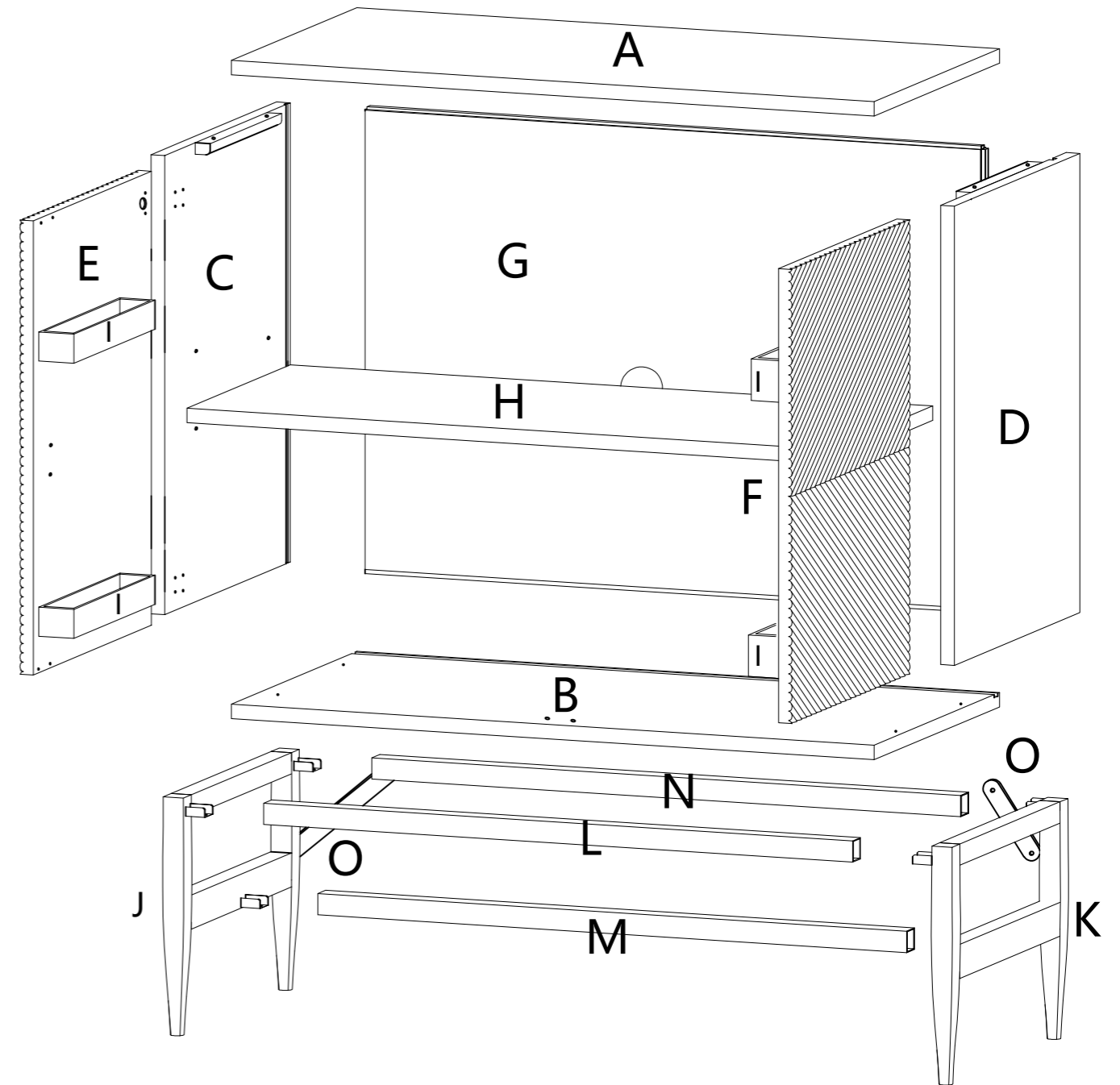

PARTS LIST

| | | | | | | | |
|----------|-----------|----------|-----------|----------|-----------|----------|-----------|
| A | x1 | B | x1 | C | x1 | D | x1 |
| | | | | | | | |
| E | x1 | F | x1 | G | x1 | H | x1 |
| | | | | | | | |
| I | x4 | J | x1 | K | x1 | L | x1 |
| | | | | | | | |
| M | x1 | N | x1 | O | x2 | | |
| | | | | | | | |

ASSEMBLY INSTRUCTIONS



| | | | | | | | |
|------------|-----------|------------|-----------|------------|-----------|------------|-----------|
| #10 | x4 | #10 | x2 | #10 | x4 | #14 | x1 |
| | | | | | | | |
| | | | | Ø4*35mm | | | |

STEP-15

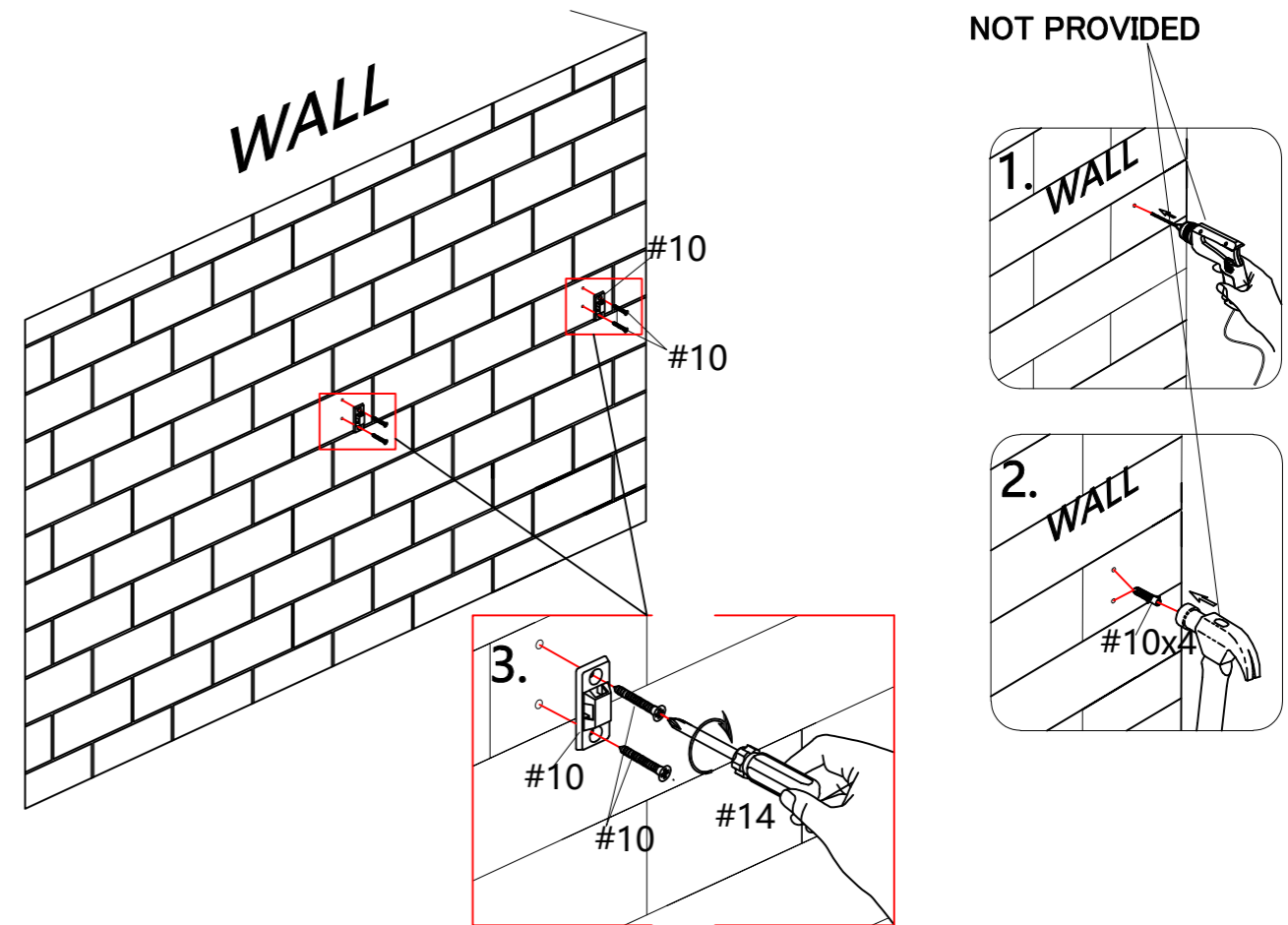
1. Install the anti-collapse device.
2. Mark the position on the wall, that corresponds to the location of part #10 on the of panel (A); Drill and insert the expandable screw #10 by hammer.
3. Assemble the part #10 to the wall. Align the hole in the part #10 with the expandable screw #10, use screw #10 to attach it and tighten by screwdriver #10.



ASSEMBLY INSTRUCTIONS

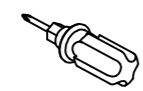





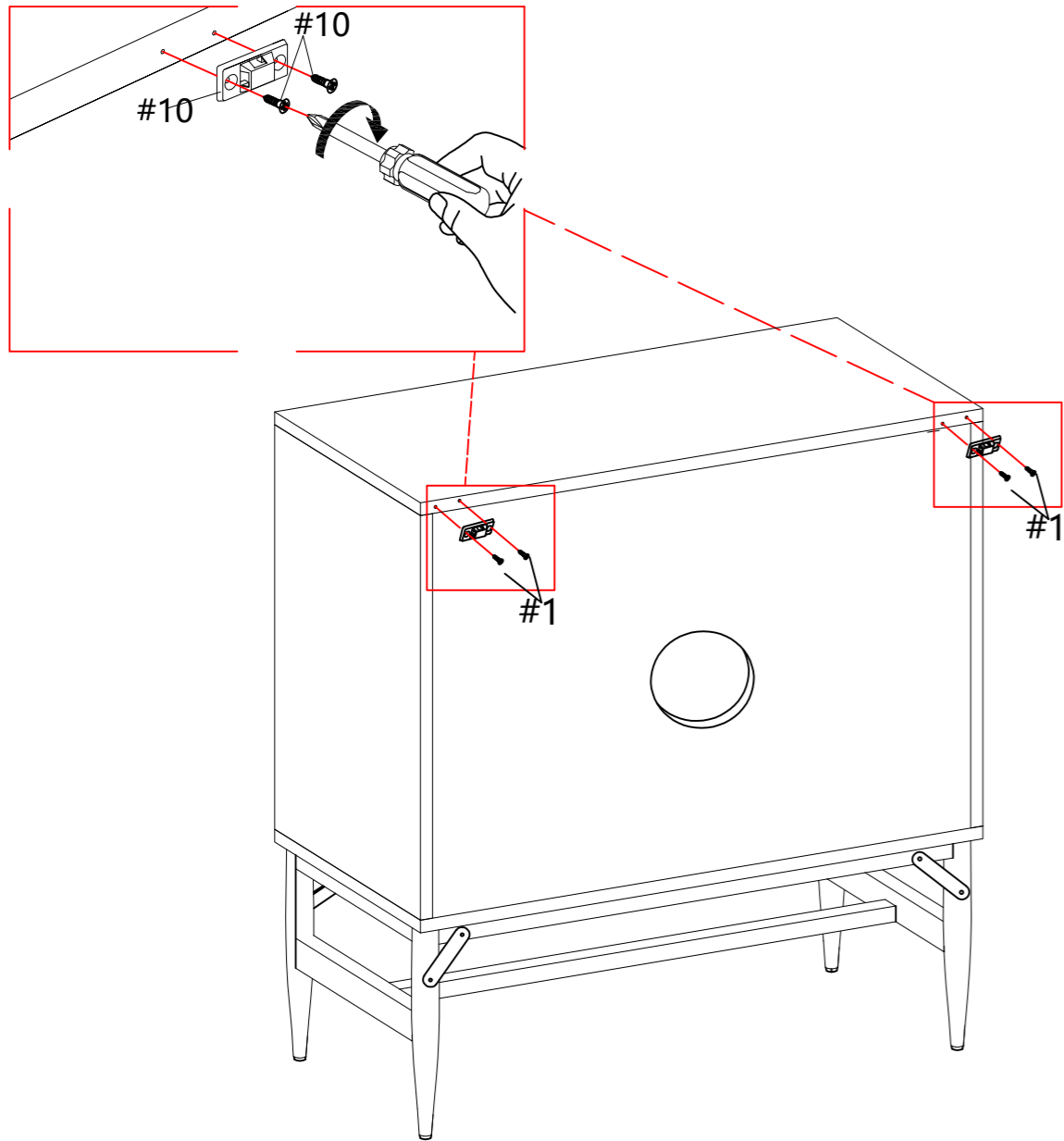

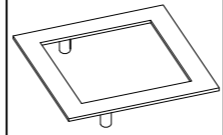

| | | | | | |
|---|----|---|----|---|----|
| #10 | x4 | #10 | x2 | #14 | x1 |
|  | |  | |  | |
| Ø3.5*15mm | | | | | |

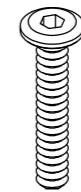
STEP-14

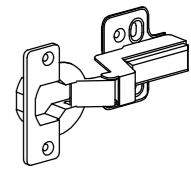

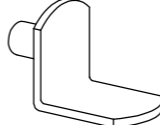
1. Use screw #1 to attach part #10 to pre-assemble unit at step 31, tighten screws with screwdriver.

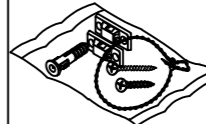





HARDWARE LIST

| | | | | | | | | | | | |
|---|-----|---|-----|---|-----|---|-----|---|-----|---|----|
| #1 | x1 | #2 | x16 | #3 | x18 | #4 | x30 | #5 | x30 | #6 | x4 |
|  | |  | |  | |  | |  | |  | |
| 110x110mm | | Ø1/4"x15mm | | Ø1/4"x30mm | | Ø1/4"X16mm | | Ø1/4"X11mm | | | |
| #7 | x36 | #8 | x4 | #9 | x10 | #10 | x2 | #11 | x2 | #12 | x4 |
|  | |  | |  | |  | |  | |  | |
| Ø3.5X15mm | | | | Ø5/32"x15mm | | Tripping Restraint hardware Kit | | | | | |

TOOL LIST

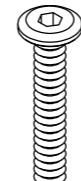
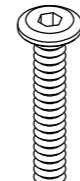
| | | | |
|---|----|---|----|
| #13 | x1 | #14 | x1 |
|  | |  | |
| M6 | | | |

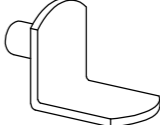
HARDWARE SPARE LIST

| | | | | | | | | | | | |
|---|----|---|----|---|----|---|----|---|----|---|----|
| #1 | x1 | #2 | x1 | #3 | x2 | #4 | x1 | #5 | x2 | #6 | x2 |
|  | |  | |  | |  | |  | |  | |
| Ø1/4"x30mm | | Ø1/4"x15mm | | Ø3.5x15mm | | | | Ø1/4"X16mm | | Ø1/4"X11mm | |

ASSEMBLY INSTRUCTIONS

STEP-1

1. Assemble the magnetic catch (#11) on the top board(A) and bottom board(B) with screws (#7)

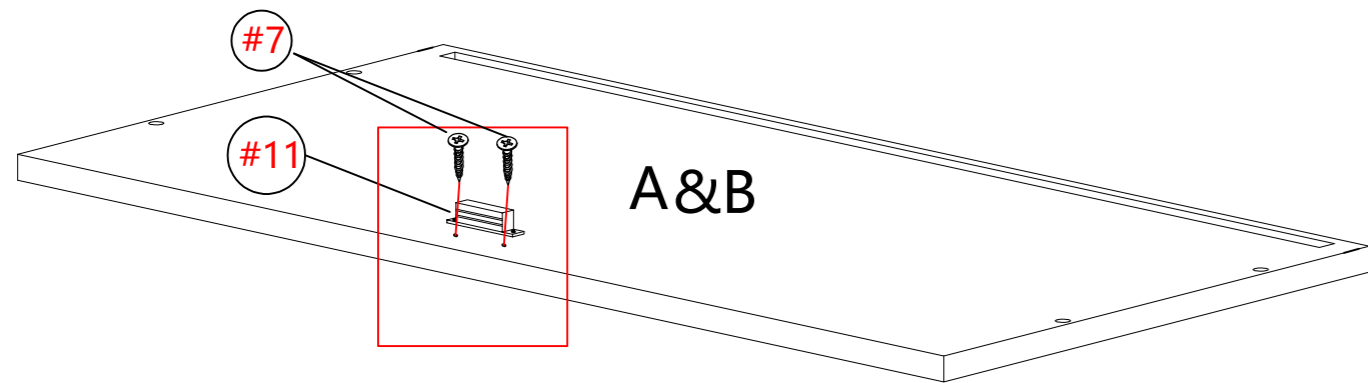
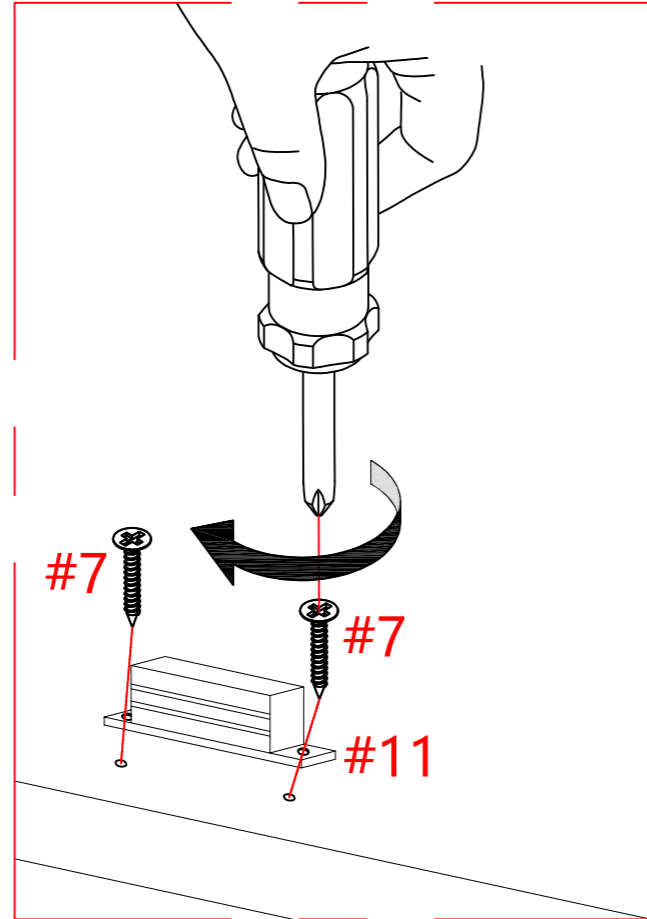

| | | | |
|-----|----|-----------|----|
| #11 | x2 | #7 | x4 |
| | | | |
| | | Ø3.5X15mm | |

06/23

ASSEMBLY INSTRUCTIONS

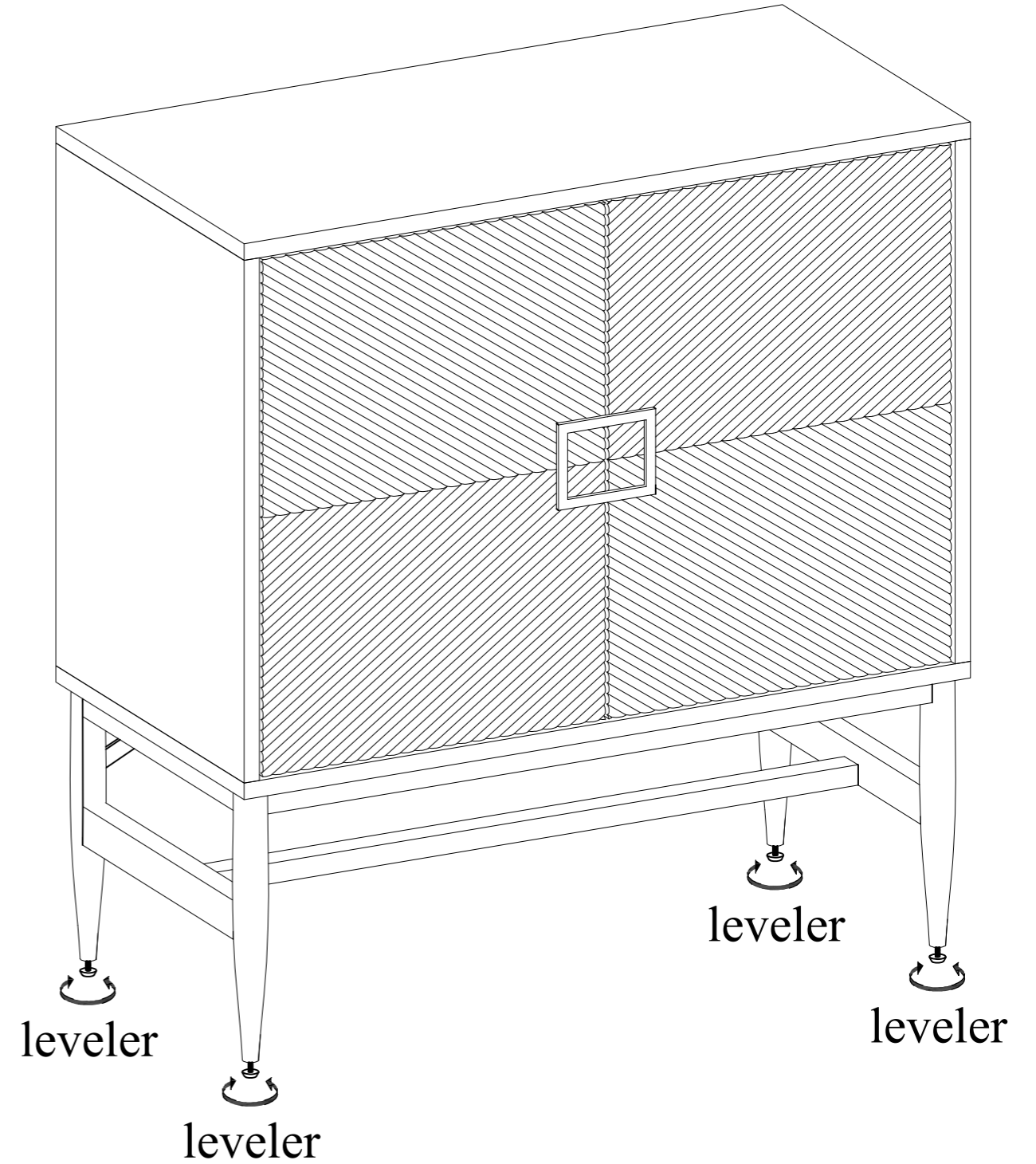

ASSEMBLY INSTRUCTIONS

STEP-13

1. Tighten the handle(#1) with bolt(#9)

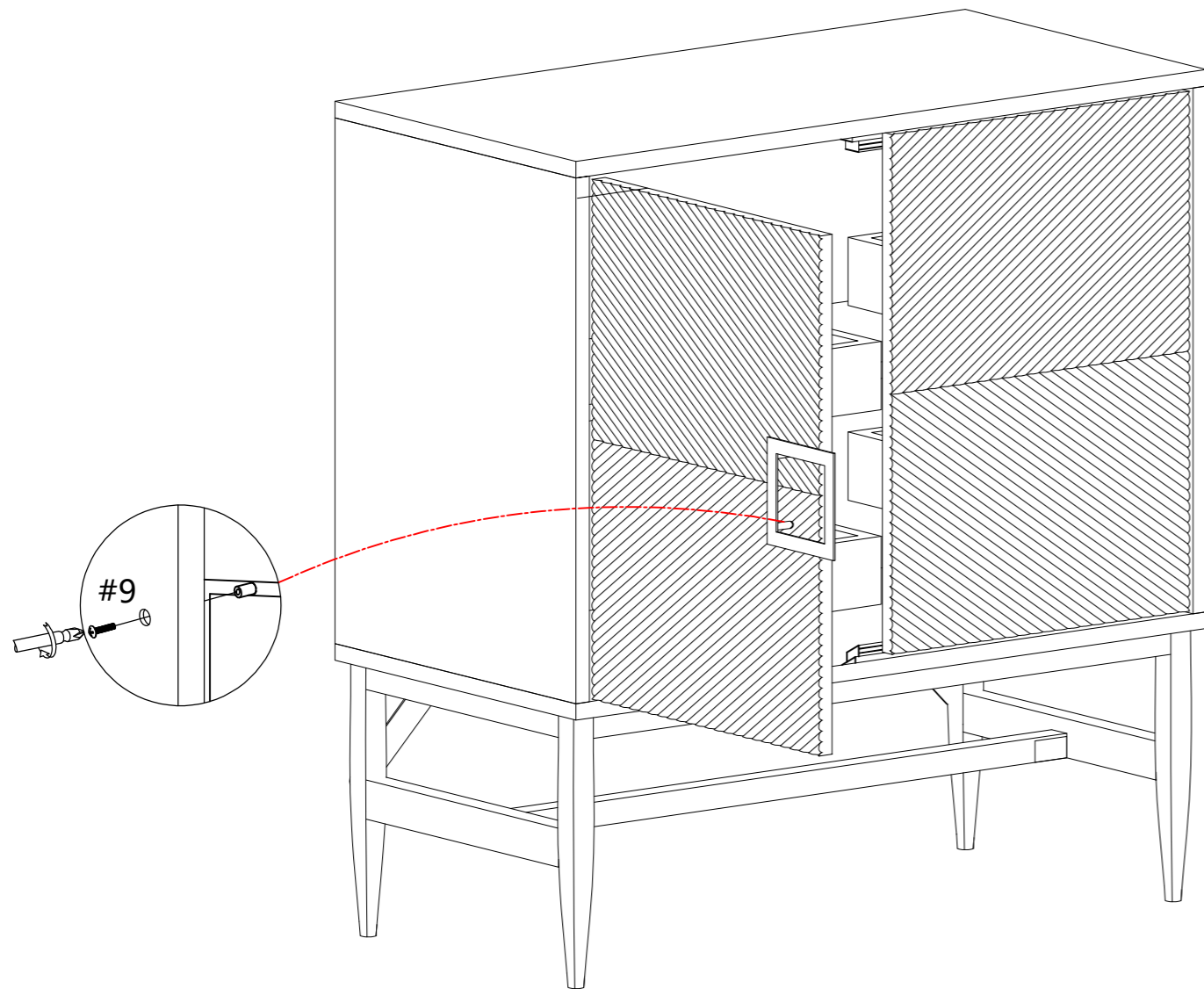

| | |
|-------------|----|
| #9 | x2 |
| | |
| Ø5/32"X15mm | |

18/23

ASSEMBLY INSTRUCTIONS

STEP-2

1. Turn the top board (A) up side down ,assemble the side board(C) use bolt(#3), spring washer(#5) and flat washer(#4) with allen key tieghten it.
2. Repeat on (D)right sideboard.

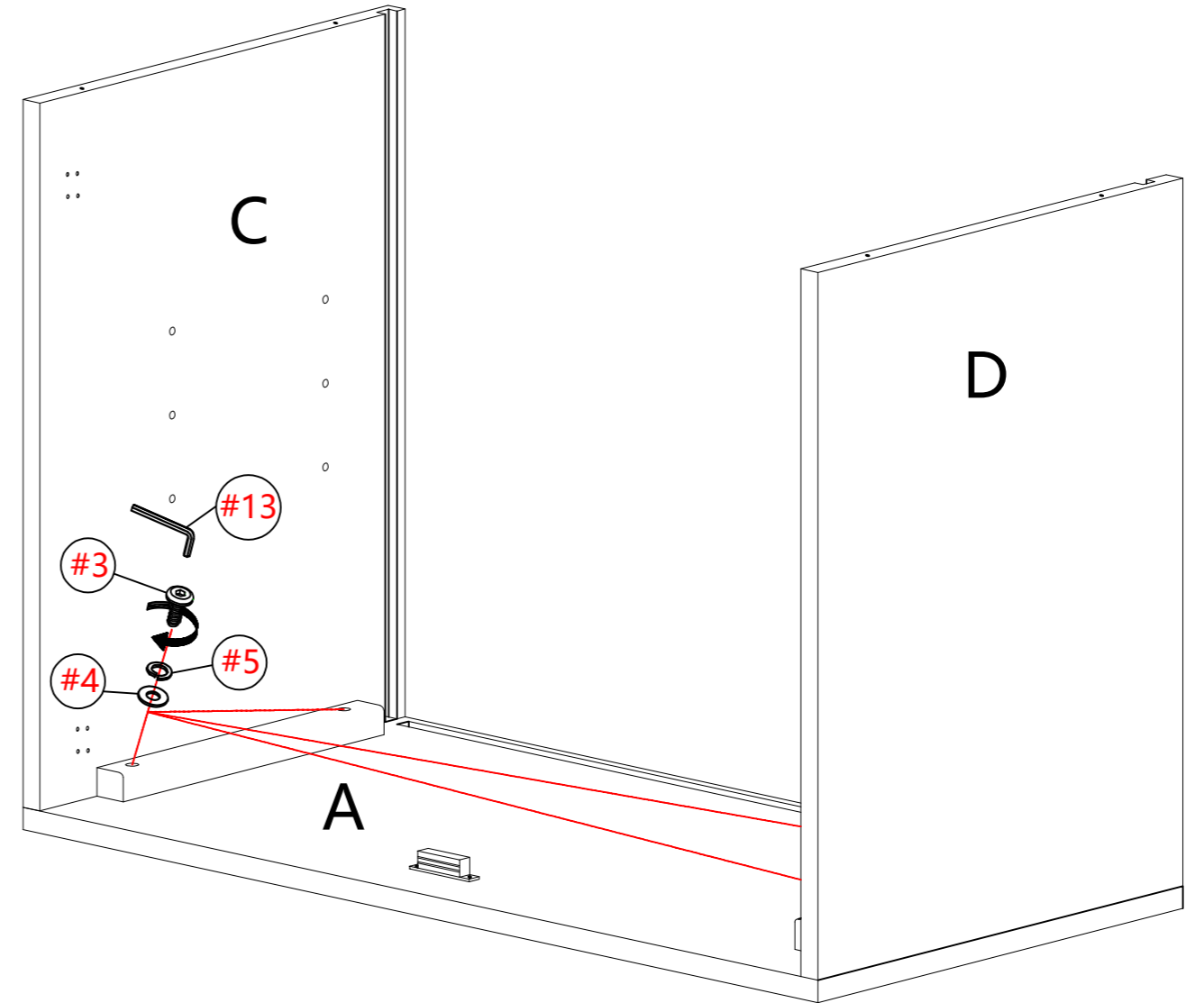

| | | | | | |
|------------|----|------------|----|------------|----|
| #3 | x4 | #4 | x4 | #5 | x4 |
| | | | | | |
| Ø1/4"x30mm | | Ø1/4"X16mm | | Ø1/4"X11mm | |

07/23

ASSEMBLY INSTRUCTIONS

STEP-3

1. Insert the (G) backboard into (C)(D) two sideboard then push until it flat.

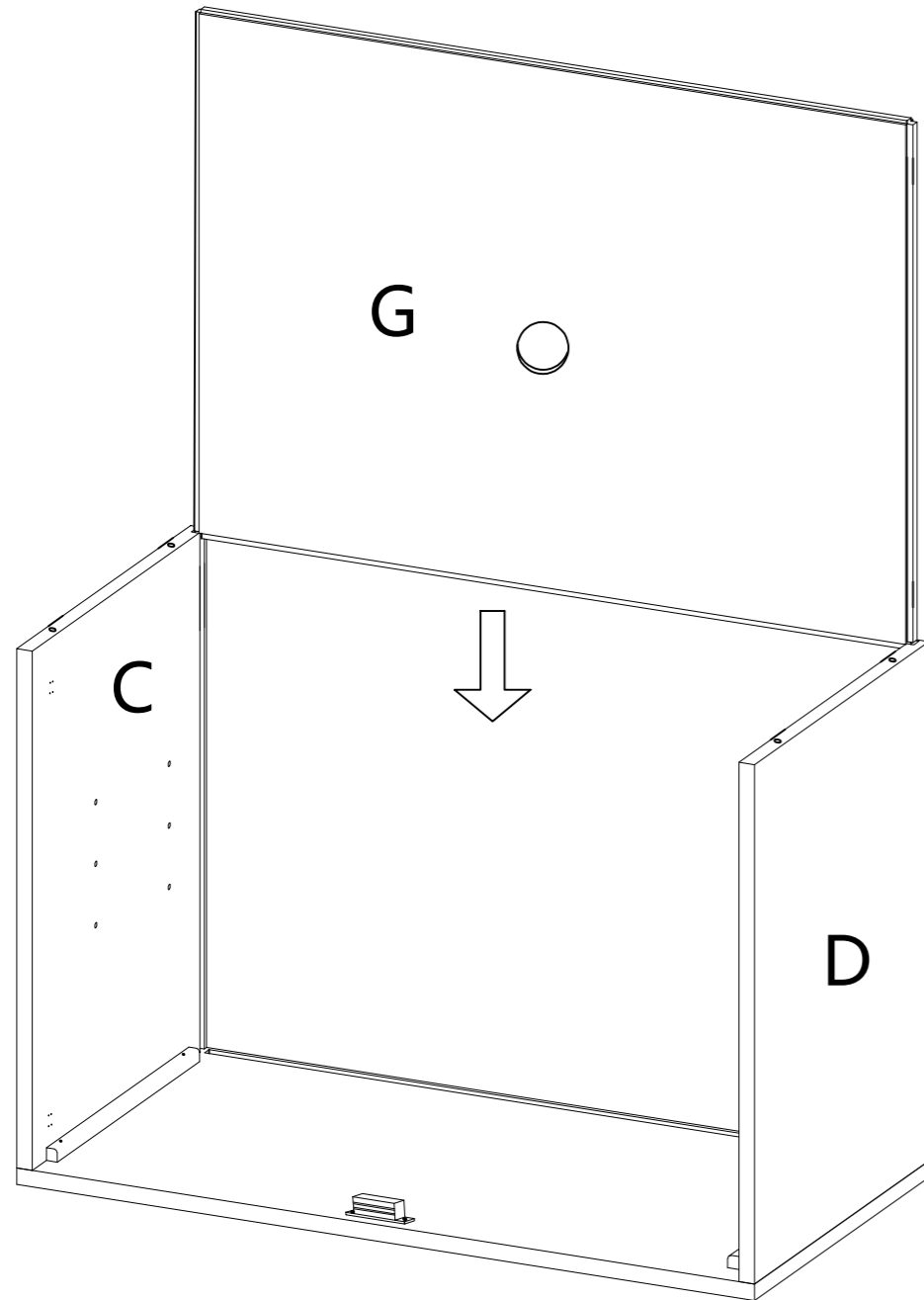

ASSEMBLY INSTRUCTIONS

STEP-12

CM ncealed hinges are three-way adjustable:

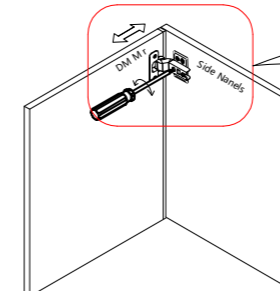

HM rizM ntal
by screw adjustment!

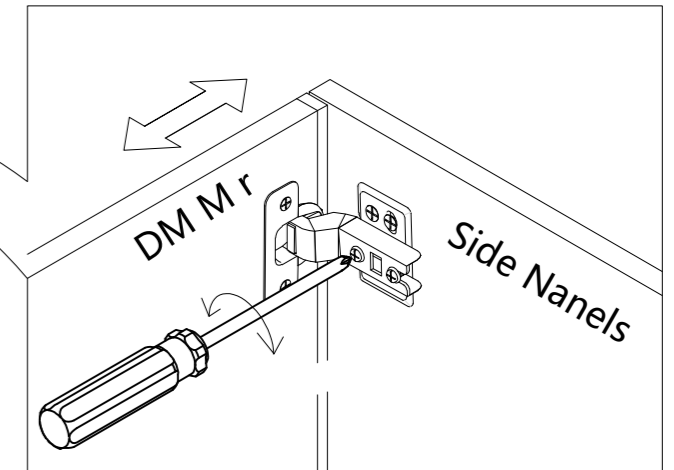

CM ncealed hinges are three-way adjustable:

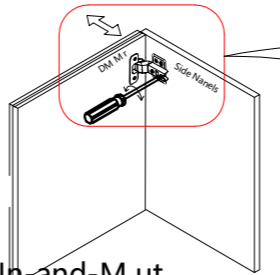

In-and-M ut
by IM M sening the hinge arm
mM untng screw M r via cam
adjustment!

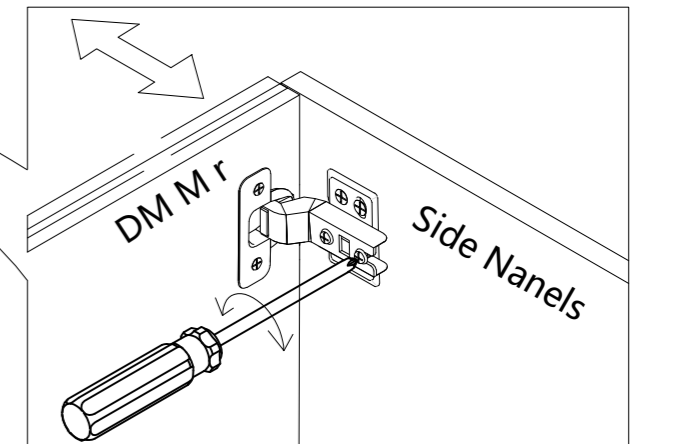

CM ncealed hinges are three-way adjustable:

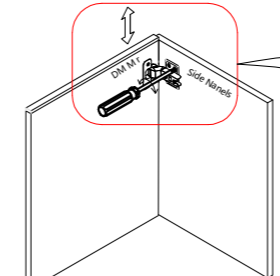

Vertical via sIM ts in
the mM untng Nlate
M r via cam adjustment!

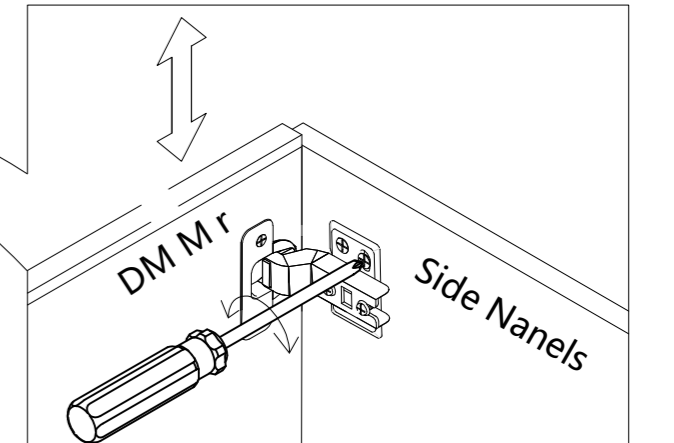

Video for door adjustment

Hinge adjustment method

ASSEMBLY INSTRUCTIONS

STEP-11

1. Assemble the European hinge with screw(#7)

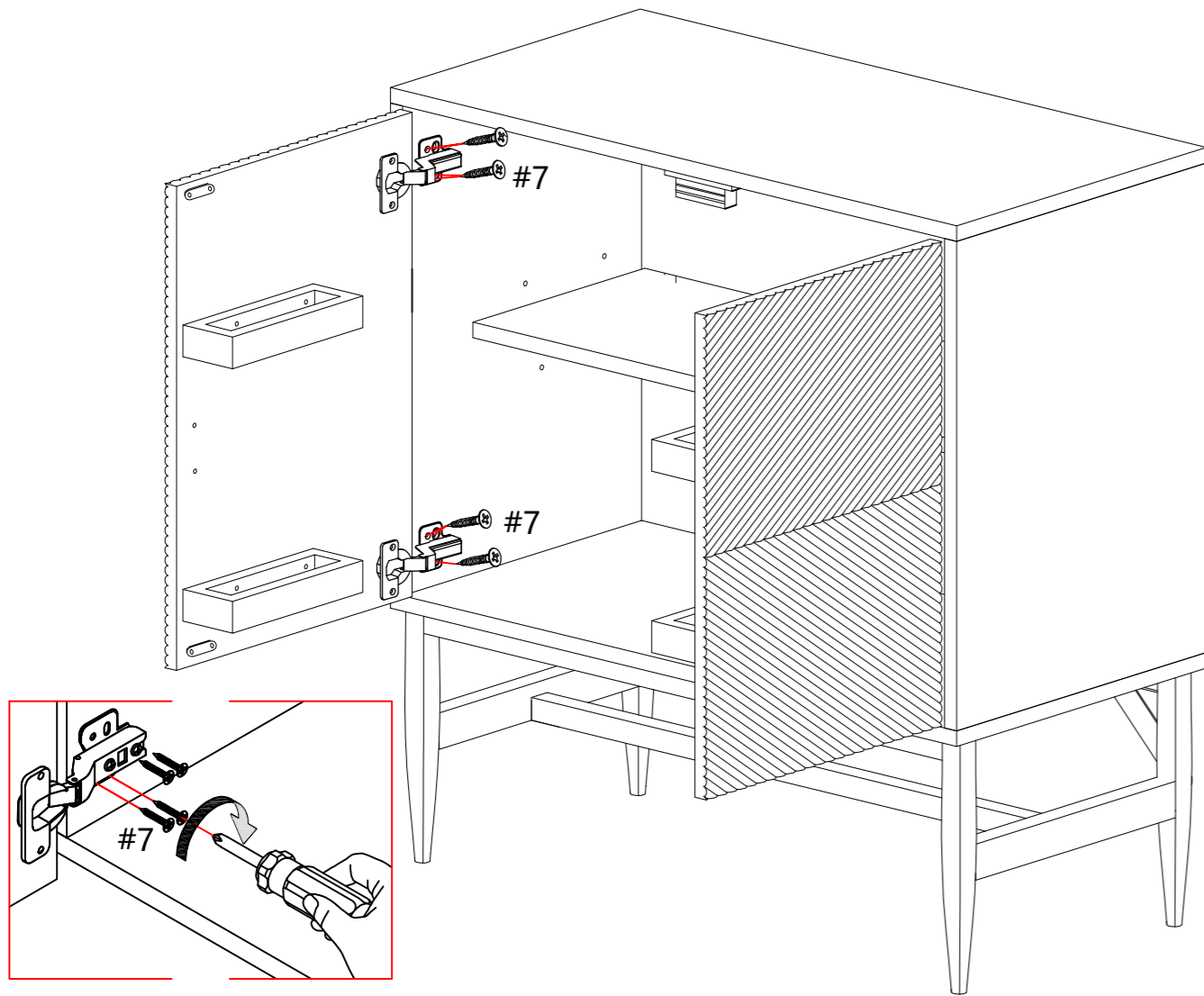

| | |
|---|-----|
| #7 | x16 |
|  | |
| Ø3.5X15mm | |

16/23

ASSEMBLY INSTRUCTIONS

STEP-4

1. Alignment the holes of bottom board(B) and assemble two side board use the bolt(#3) tighten with allen key.

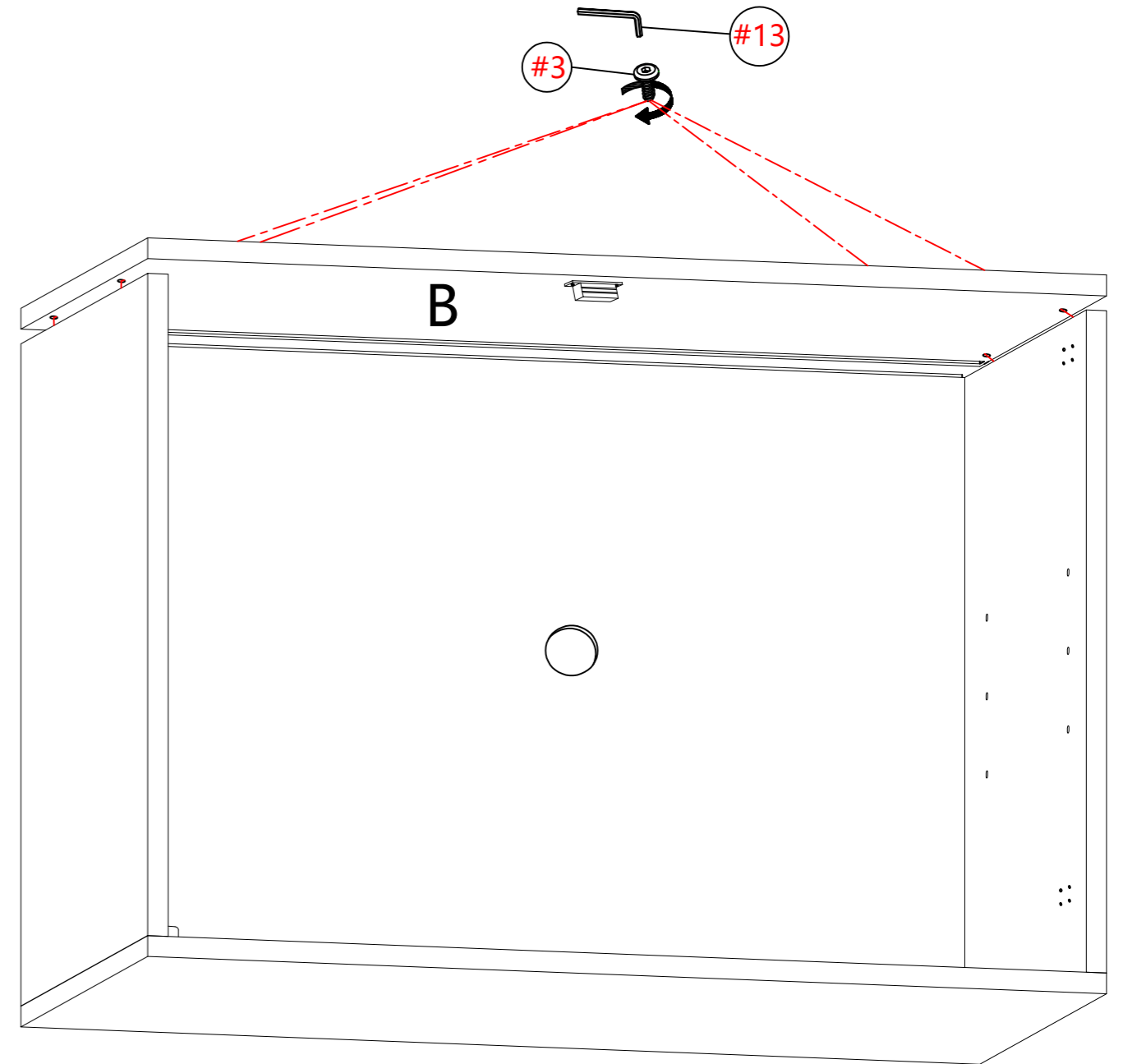

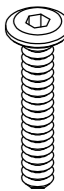
| | |
|---|----|
| #3 | x4 |
|  | |
| Ø1/4"x30mm | |

09/23

ASSEMBLY INSTRUCTIONS

STEP-5

1. Follow the instruction insert the metal stretcher (L)(M)(N) on side metal support legs(J)
2. Follow the instruction use the bolt(#2), spring washer(#5) and flat washer(#4) tighten the metal stretch with allen key

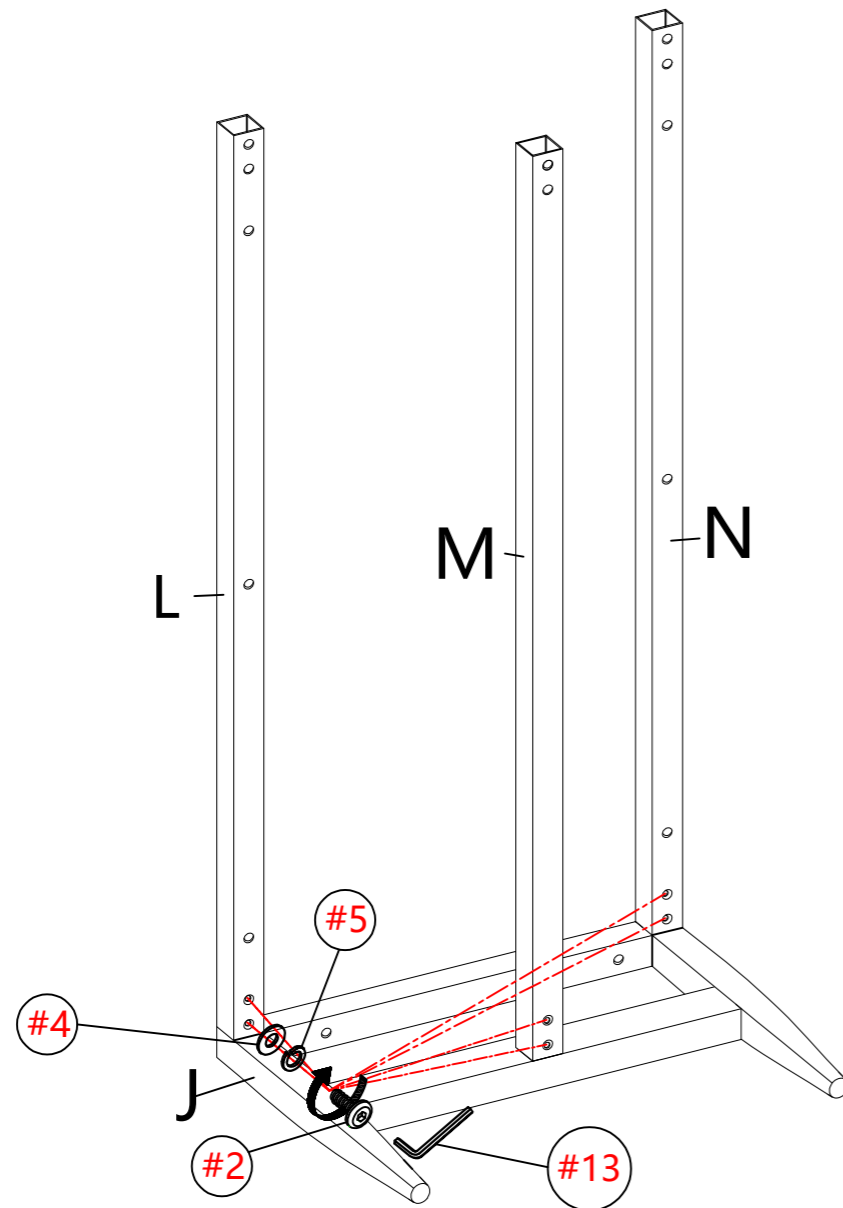

| | | | | | |
|------------|----|------------|----|------------|----|
| #2 | x6 | #4 | x6 | #5 | x6 |
| | | | | | |
| Ø1/4"x15mm | | Ø1/4"X16mm | | Ø1/4"X11mm | |

ASSEMBLY INSTRUCTIONS

STEP-10

1. Assemble the box(I) on the door(E) (F) with bolt (#9)
2. Assemble the European(#6) hinge with screw(#7)
3. Assemble the magnetic attach(#12) with screw(#7)

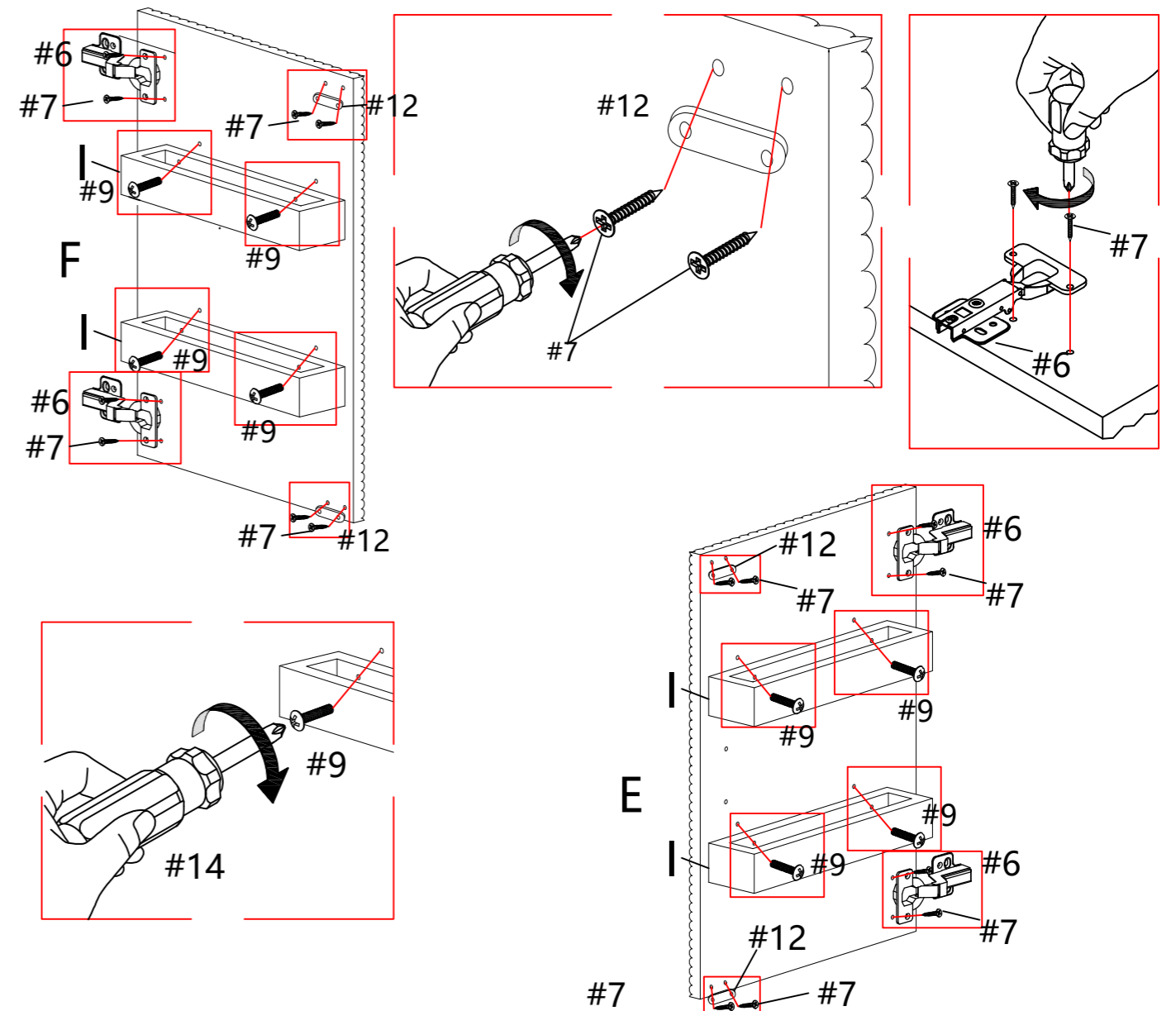

| | | | | | | | |
|-----|----|-------------|----|----|----|-----------|-----|
| #12 | x4 | #9 | x8 | #6 | x4 | #7 | x16 |
| | | | | | | | |
| | | Ø5/32"x15mm | | | | Ø3.5X15mm | |

ASSEMBLY INSTRUCTIONS

STEP-9

1. Put Adjust board(H) on the shelf support(#8).

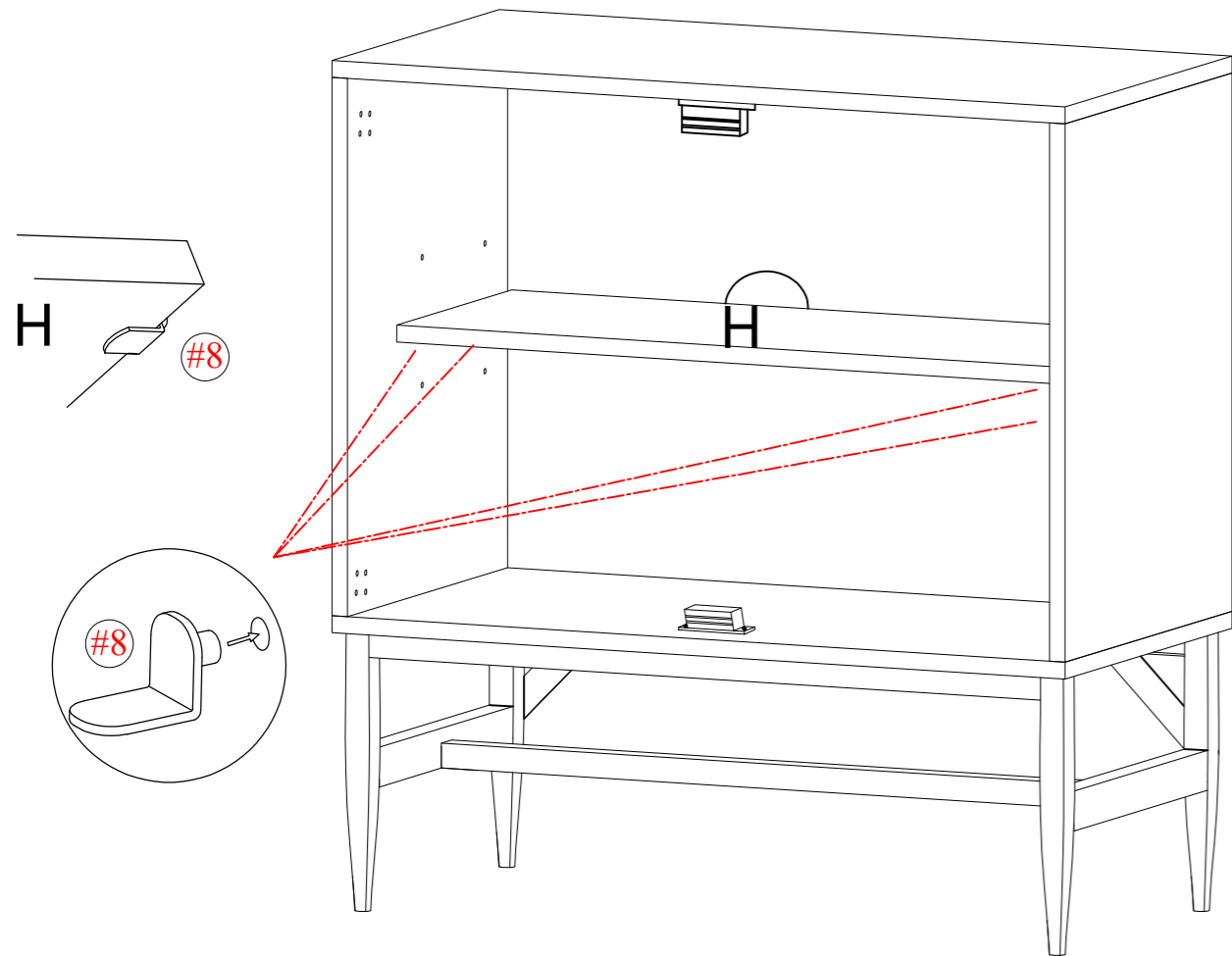

| | |
|----|----|
| #8 | x4 |
| | |

14/23

ASSEMBLY INSTRUCTIONS

STEP-6

1. Follow the instruction insert the metal stretcher (L)(M)(N) on side metal support legs(K)
2. Follow the instruction use the bolt(#2), spring washer(#5) and flat washer(#4) tighten the metal stretch with allen key

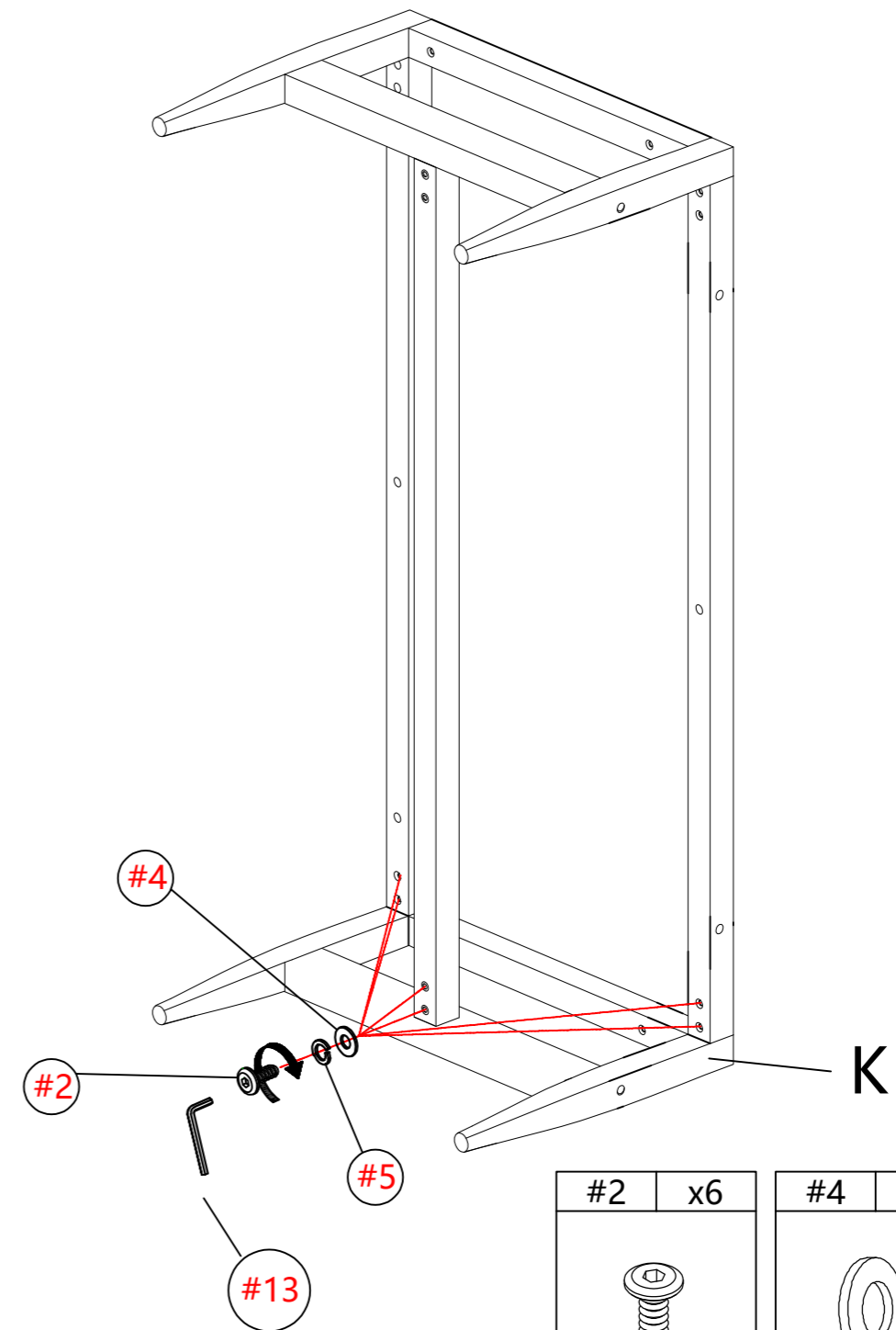

| | |
|------------|----|
| #2 | x6 |
| | |
| Ø1/4"x15mm | |

| | |
|------------|----|
| #4 | x6 |
| | |
| Ø1/4"X16mm | |

| | |
|------------|----|
| #5 | x6 |
| | |
| Ø1/4"X11mm | |



11/23

ASSEMBLY INSTRUCTIONS

STEP-7

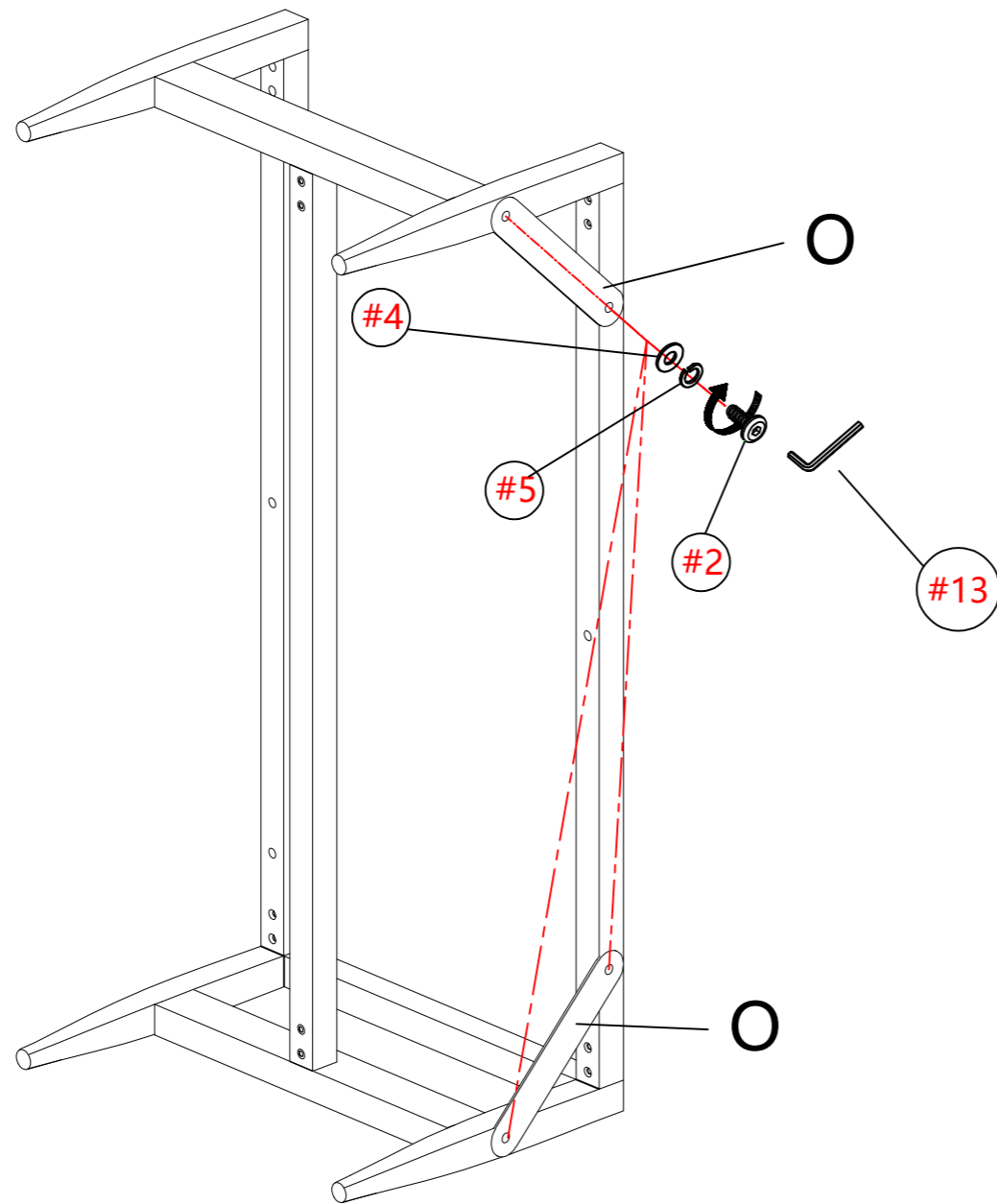
1. Assemble the metal connect sheet(O) ,use the bolt(#2),spring washer(#5) and flat washer(#4) with allen key tieghten it.





| | | | | | |
|---|----|---|----|---|----|
| #2 | x4 | #4 | x4 | #5 | x4 |
|  | |  | |  | |
| Ø1/4"x15mm | | Ø1/4"X16mm | | Ø1/4"X11mm | |

ASSEMBLY INSTRUCTIONS

STEP-8

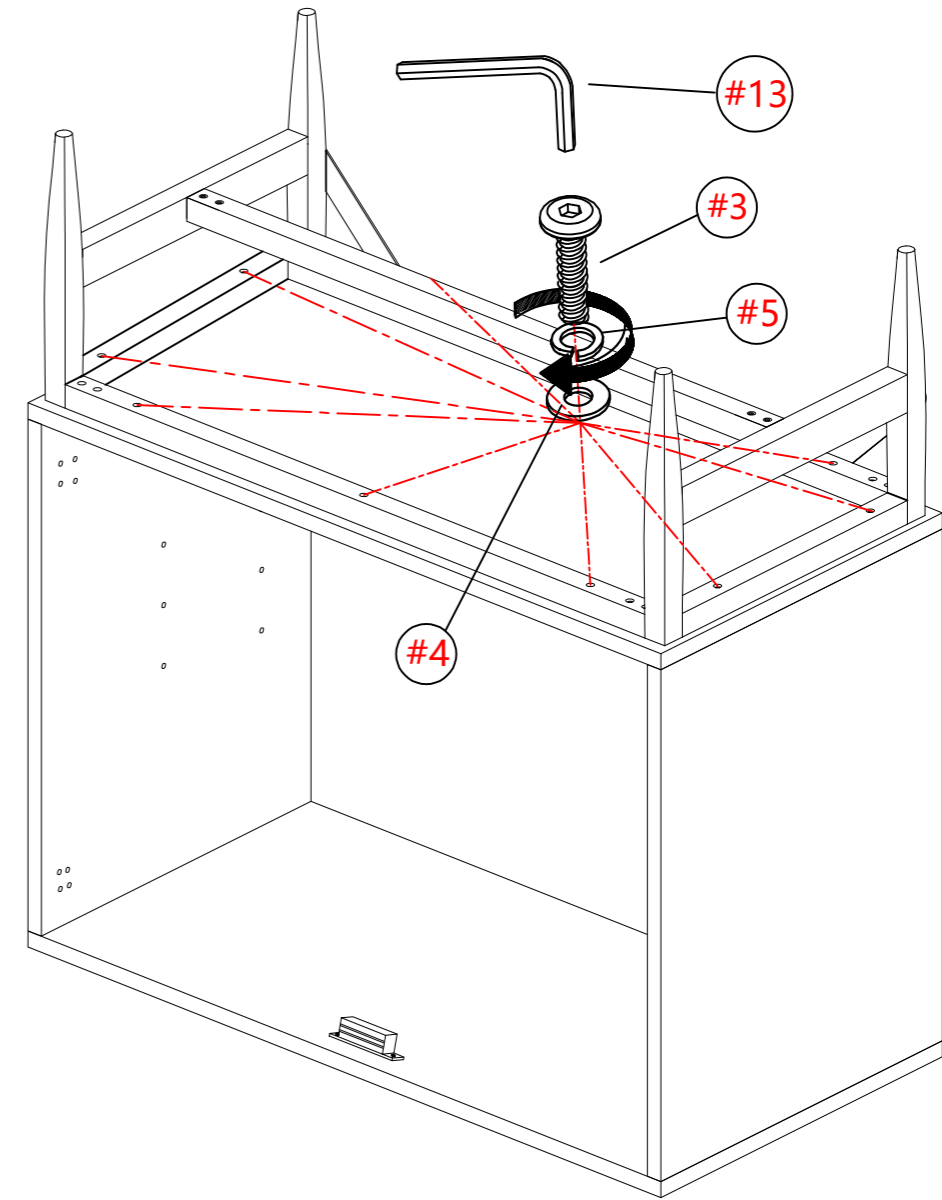
1. Turn the whole case up side down ,assemble the legs use the bolt (#3) ,spring washer(#5) and flat washer(#4) tighten it with allen key.

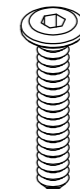
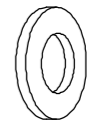

| | | | | | |
|---|-----|---|-----|---|-----|
| #3 | x10 | #4 | x10 | #5 | x10 |
|  | |  | |  | |
| Ø1/4"x30mm | | Ø1/4"X16mm | | Ø1/4"X11mm | |