

# 48" Kitchen Island with Racks & Drawers

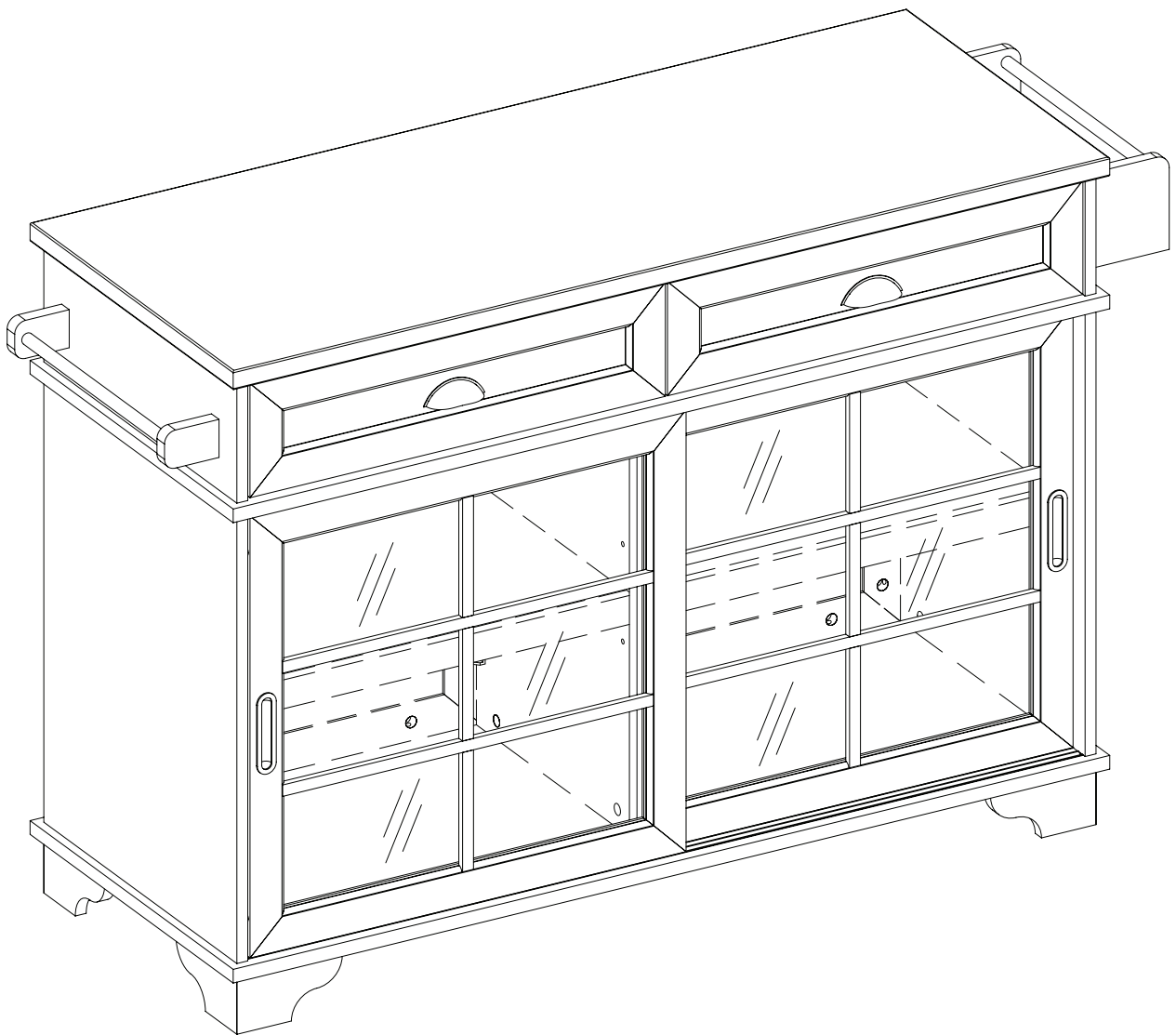

**For Residential Use Only**

Please visit our website for the most current instructions, assembly tips, report damage, or request parts.

# Time to get started

---

Set up a clean and soft workplace to get started and avoid damage during the assembly. It also helps to double-check you've got all the pieces and parts before diving in to assembly.

---

## Estimated time for assembly

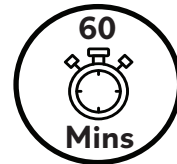

---

## People recommended for assembly

Make it a team effort! Grab a friend for quicker, easier assembly.

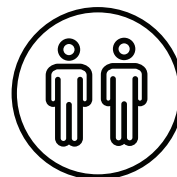

2 People Build

---

## Tools Needed

Grab a Phillips head screwdriver to conquer this assembly.

Phillips head screwdriver is not included.



---

## Use power tools with caution

You can cause cracking or damage to the material and easily strip the hardware. If you choose to use a power tool, your product will no longer be covered under warranty.

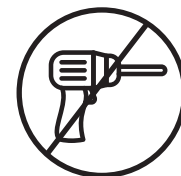





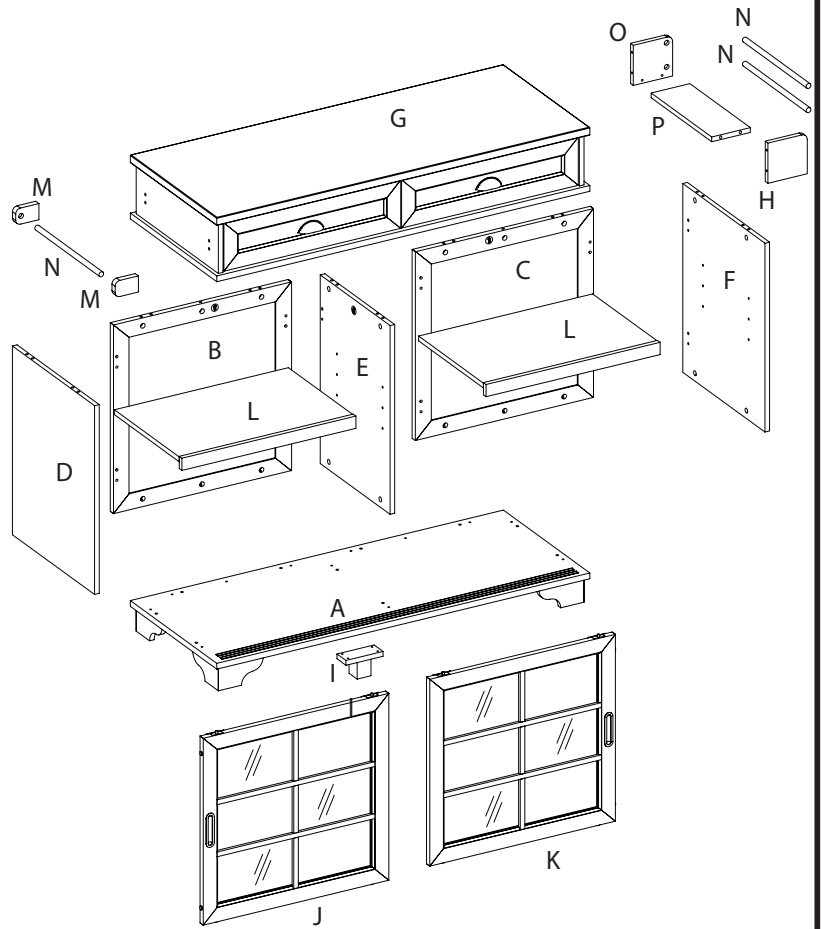

# Parts List

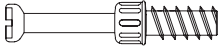
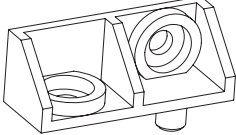
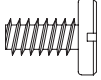
Part Number	Description	Quantity
A	Base Panel	1
B	Back Left Panel	1
C	Back Right Panel	1
D	Left Side Panel	1
E	Partition Panel	1
F	Right Side Panel	1
G	Top	1
H	Wine Right Side Panel	1
I	Center Support Leg	1
J	Left Door	1
K	Right Door	1
L	Adjustable Shelf	2
M	Towel Bar Holder	2
N	Support Rail	3
O	Wine Left Side panel	1
P	Wine Bottom Panel	1



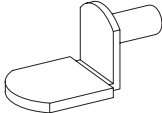
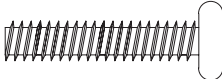
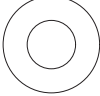

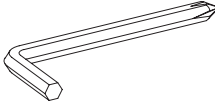
# Hardware List

Part	Size	Name	Quantity	Part code
AA 	Ø8x30mm	Wood Dowels	20	PH-DWLNTL001
BB 		Cam Lock	28	PH-KDBZNC001
CC 		Plastic Connector Block	8	PH-PCBXXX005
DD 	Ø6.3x12mm	Bolt	16	PH-BLTBLK002
EE 		Cam Lock	28	PH-KDCZNC001
FF 	Ø21mm	Plastic Cover	24	PH-KDPXXX001
GG 	Ø4x25mm	Screw	4	PH-SCRBLK021
HH 		Shelf Pin	8	PH-SPNPCSPLB2
II 	Ø6.3x32mm	Bolt	8	PH-BLTHBD6L32
JJ 	Ø16mm	Washer	8	PH-WSRZNC002
KK 	Ø10.5mm	Spring Washer	8	PH-WSRBLK003
LL 		Hexagon Wrench	1	PC-PHALKEY4MM

*The hardware quantities listed above are required for proper assembly.  
Extra hardware pieces may be included.*

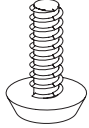
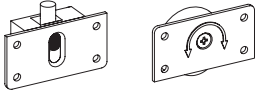
# Installed Replacements Parts

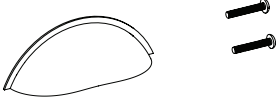
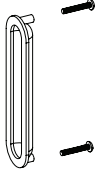
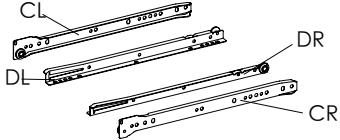
Part	Size	Name	Quantity	Part code
MM		Threaded Insert	29	PH-THRZNC001
NN		Leveler	5	PH-LVRWHT001
OO		Sliding Door Hardware	4	PH-SDHBLK001
PP		Door Bumper	8	PH-BMPCLR001
QQ		Hardware (With Screw)	2	A4677(B03)
RR		Hardware (With Screw)	2	A5270(B03)
SS		Drawer Slide 14"	2	PH-DSLBLK007

# Step 1

Time to get started! First, remove the drawers from the top (G).

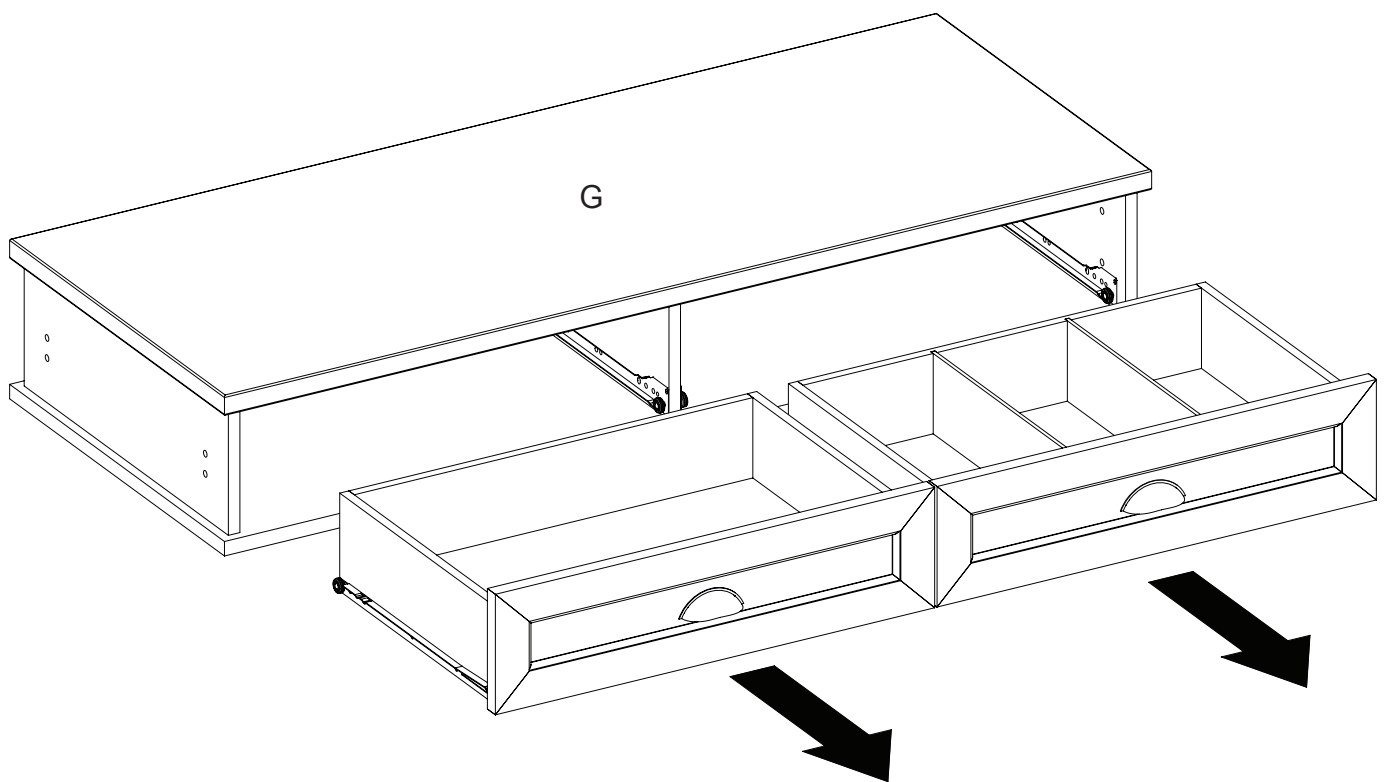

## Step 2

Then, turn the kitchen island over, insert the wood dowels (AA) and cam bolts (BB) into pre-drilled holes in the top (G) as shown below.

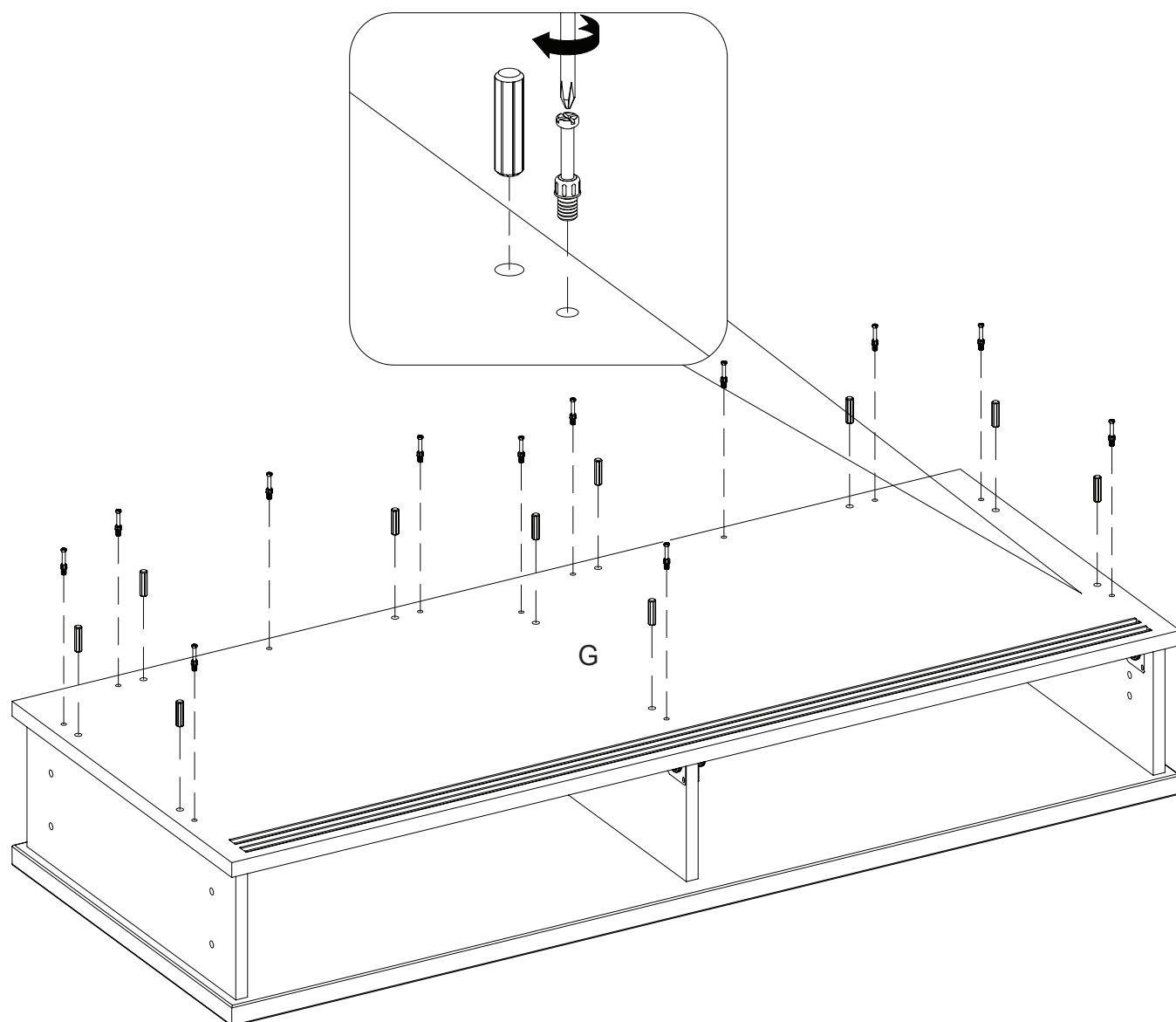

AA

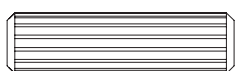

[x10]

BB

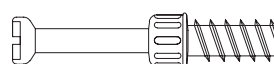

[x12]

# Step 3

Attach the plastic connector blocks (CC) into the pre-drilled holes in partition panel (E) using the bolts (DD).

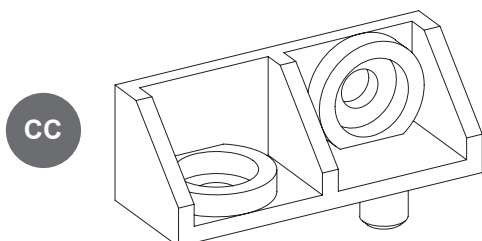
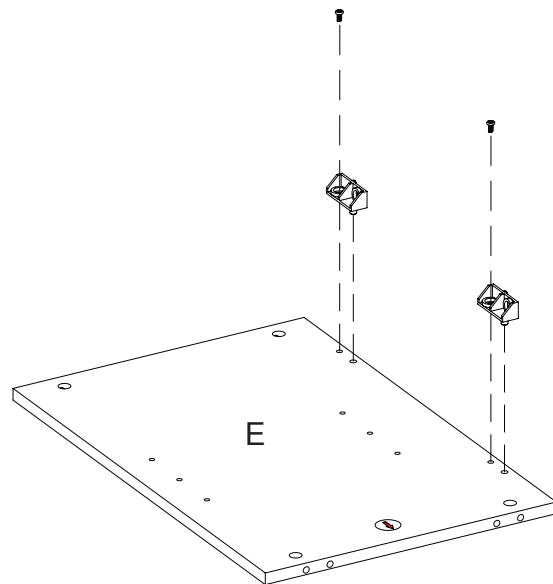
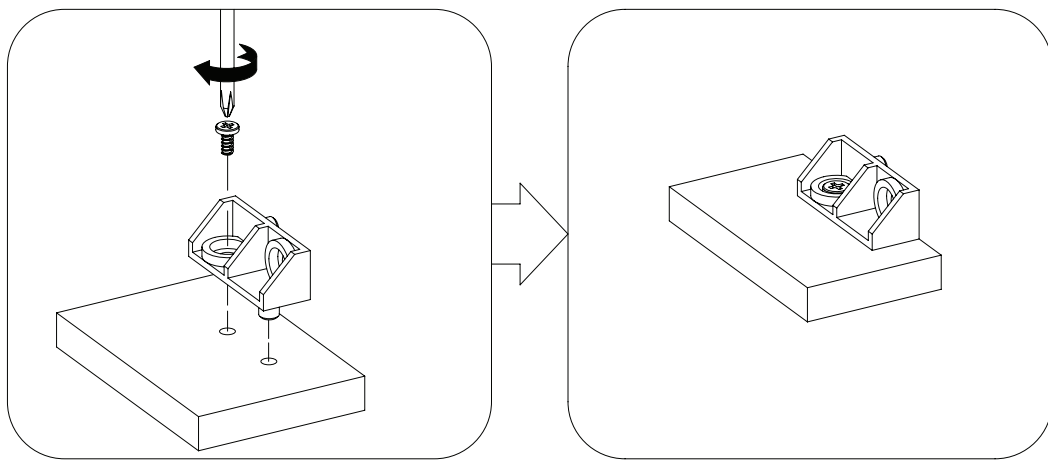

CC

[x2]



DD

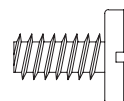

[x2]

# Step 4

Next, attach the plastic connector blocks (CC) into the pre-drilled holes in partition panel (E) with the bolts (DD).

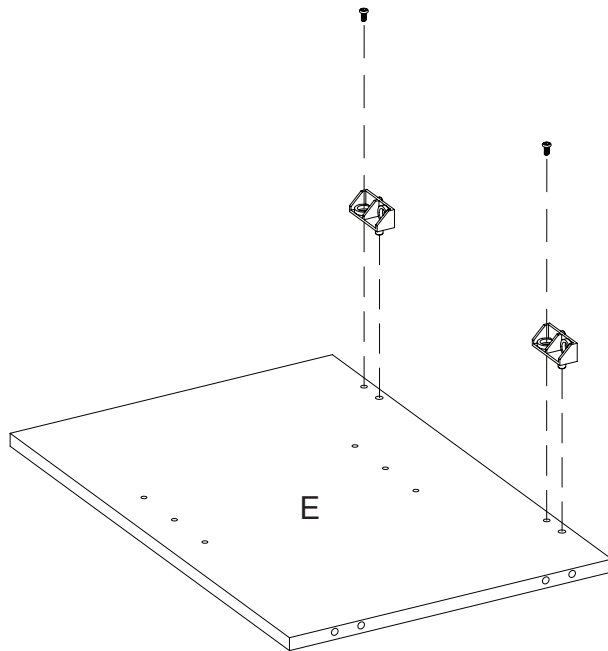
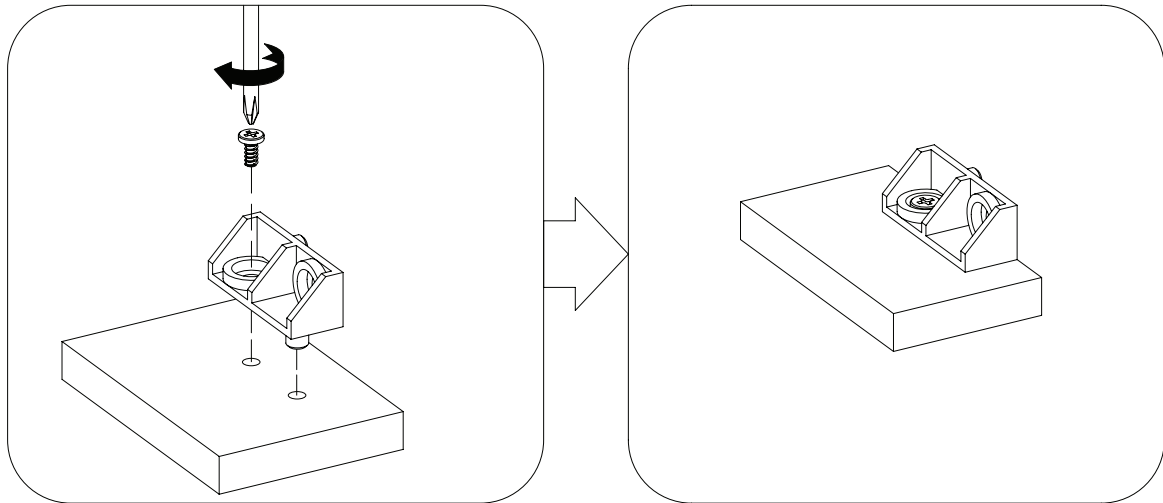

CC

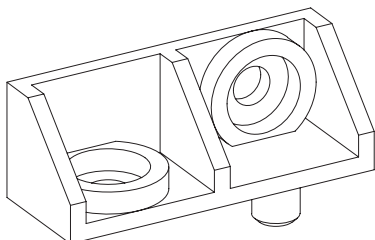

[x2]

DD

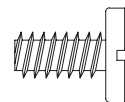

[x2]

# Step 5

Attach the plastic connector blocks (CC) into the pre-drilled holes in the back right panel (C) and the back left panel (B) using the bolts (DD).

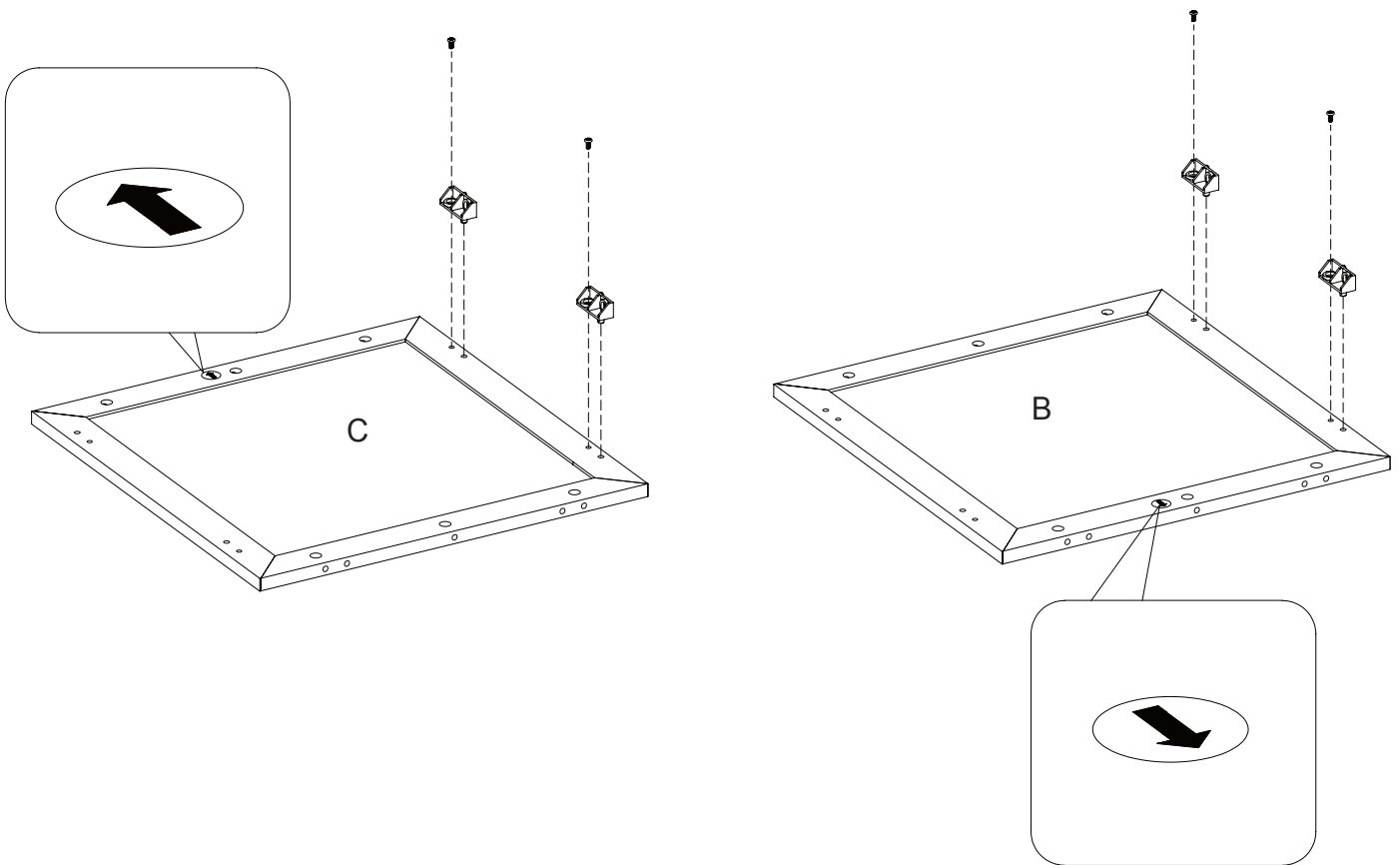
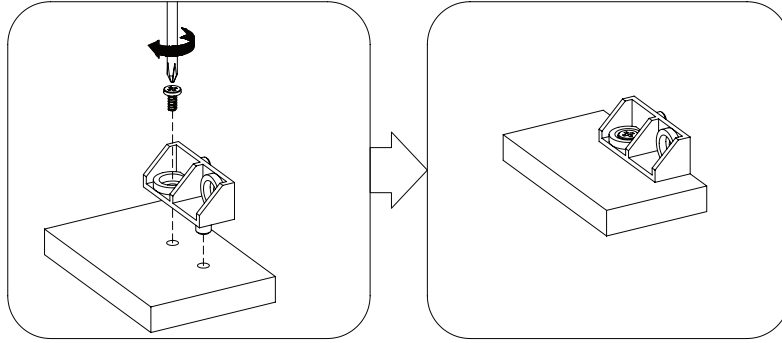

CC

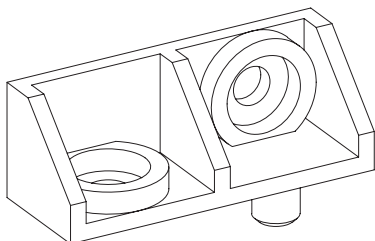

[x4]

DD

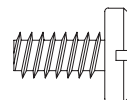

[x4]

# Step 6

Next, attach the back right panel (C) with the right side panel (F) with the bolts (DD). Then repeat a similar process for the back left panel (B) and the left side panel (D).

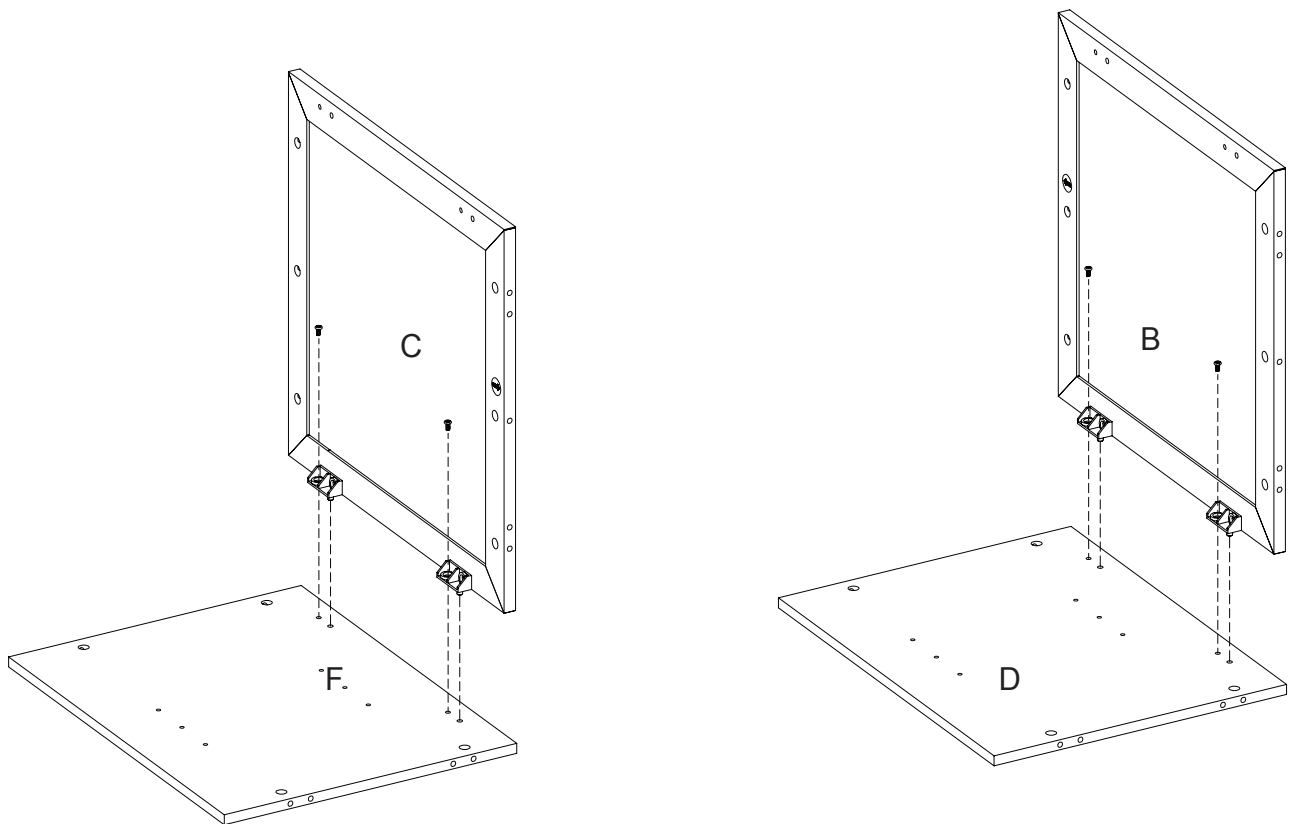
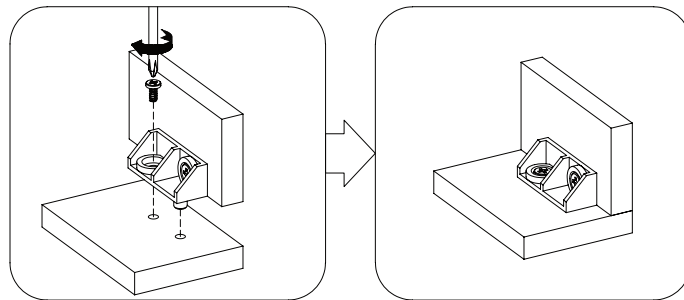

DD

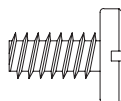

[x4]

# Step 7

Now it's time to assemble the back panels. Attach partition (E) to both the back right panel (C) and the back left panel (B) using bolts (DD). Please take care to make sure that the arrow on the partition (E) is pointing in the same direction as the image below.

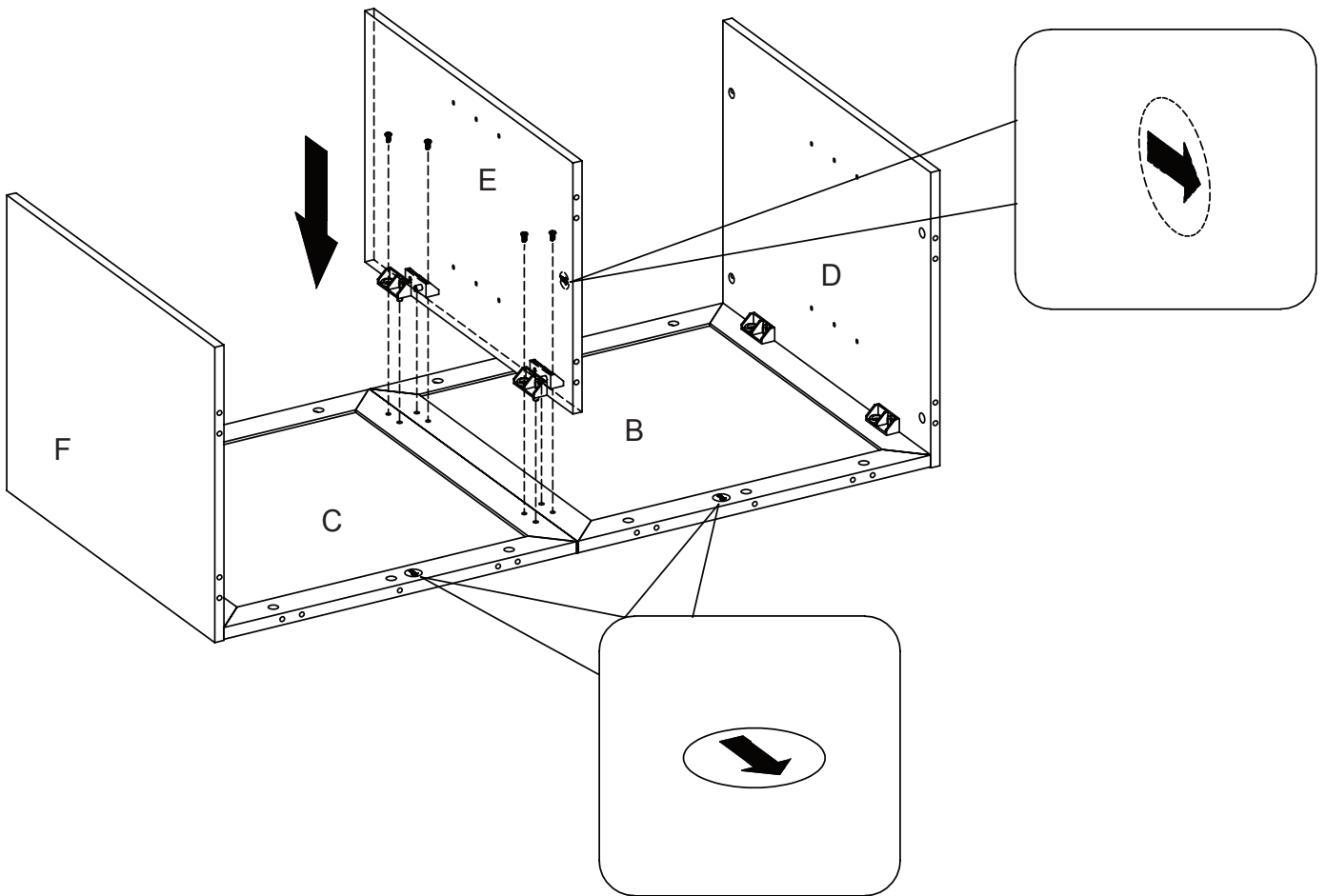
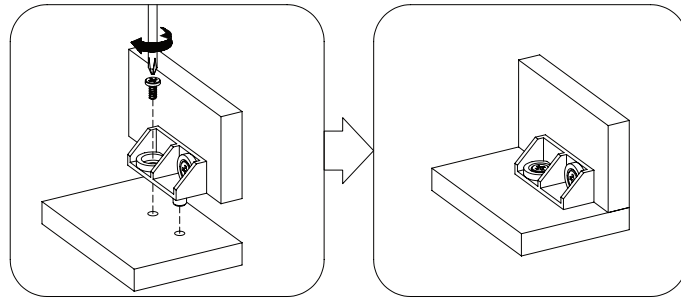

DD

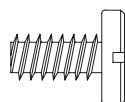

[x4]

# Step 8

It's time to put the assembled panels all together! Align the assembled unit with the pre-drilled holes in the top (G) and attach the assembled unit to the top (G). Insert and secure the cam locks (EE) into the holes as shown.

Please take care to make sure that the arrow on the partition (E) is pointing in the same direction as the image below.

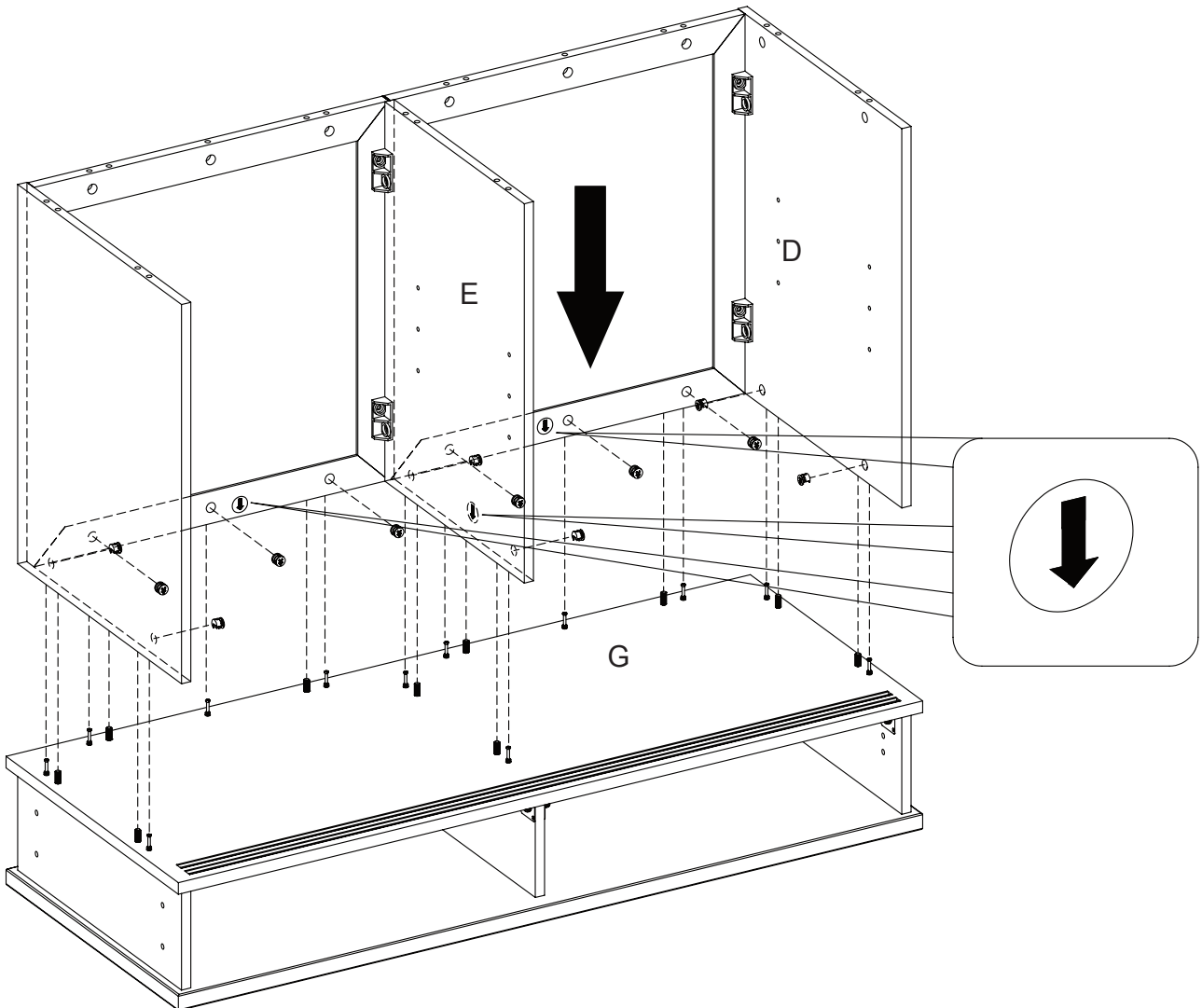
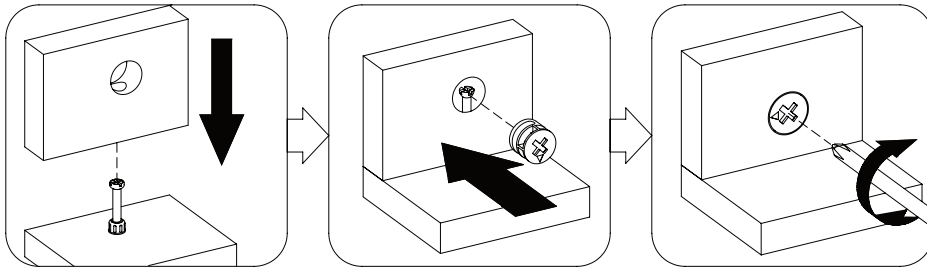

EE



[x12]

# Step 9

Now it's time to assemble the base panel. First, insert the wood dowls (AA) into the assembled unit as shown.

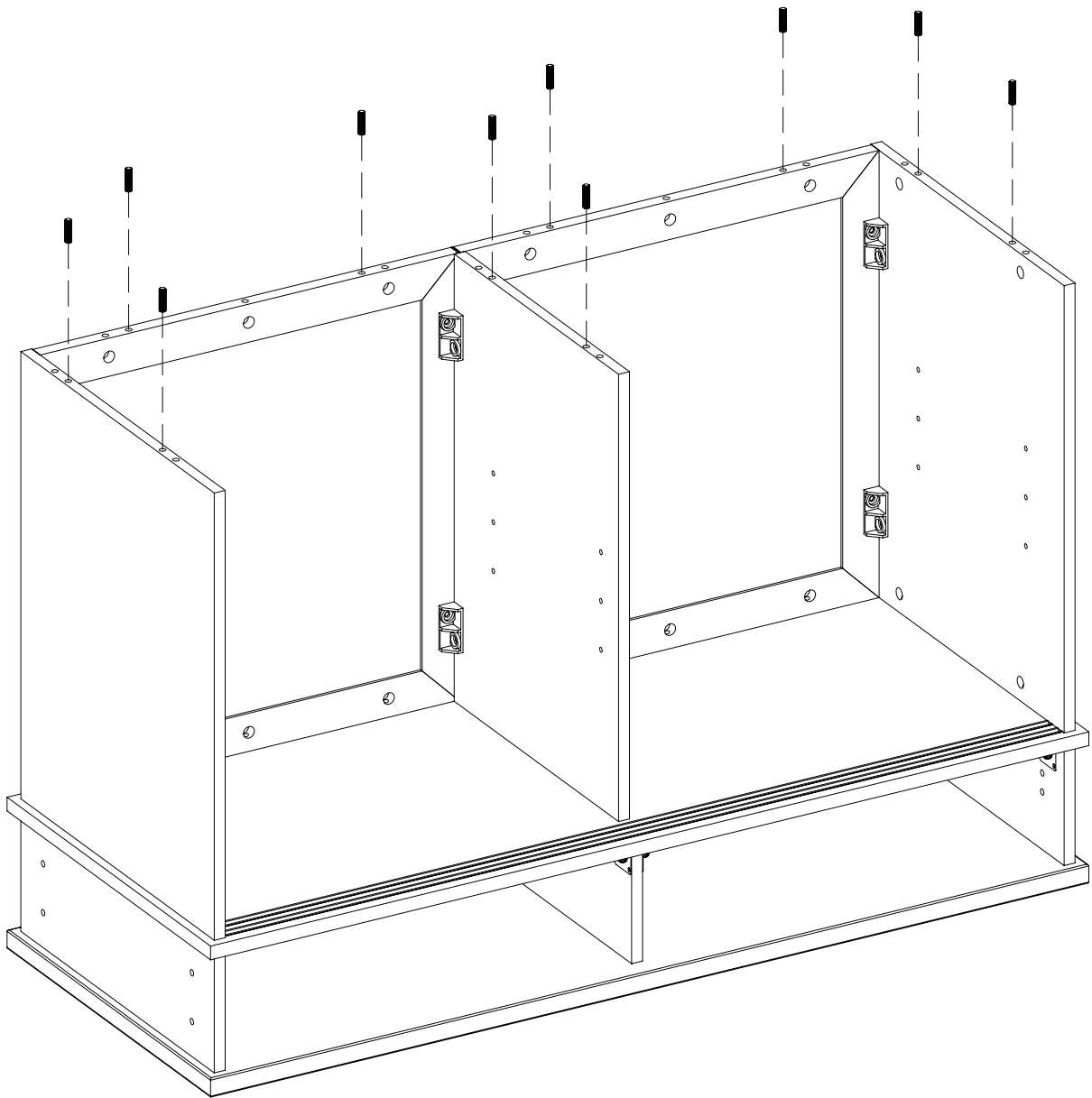

AA



[x10]

# Step 10

Then, insert and secure the cam bolts (BB) into the base panel (A) as shown.

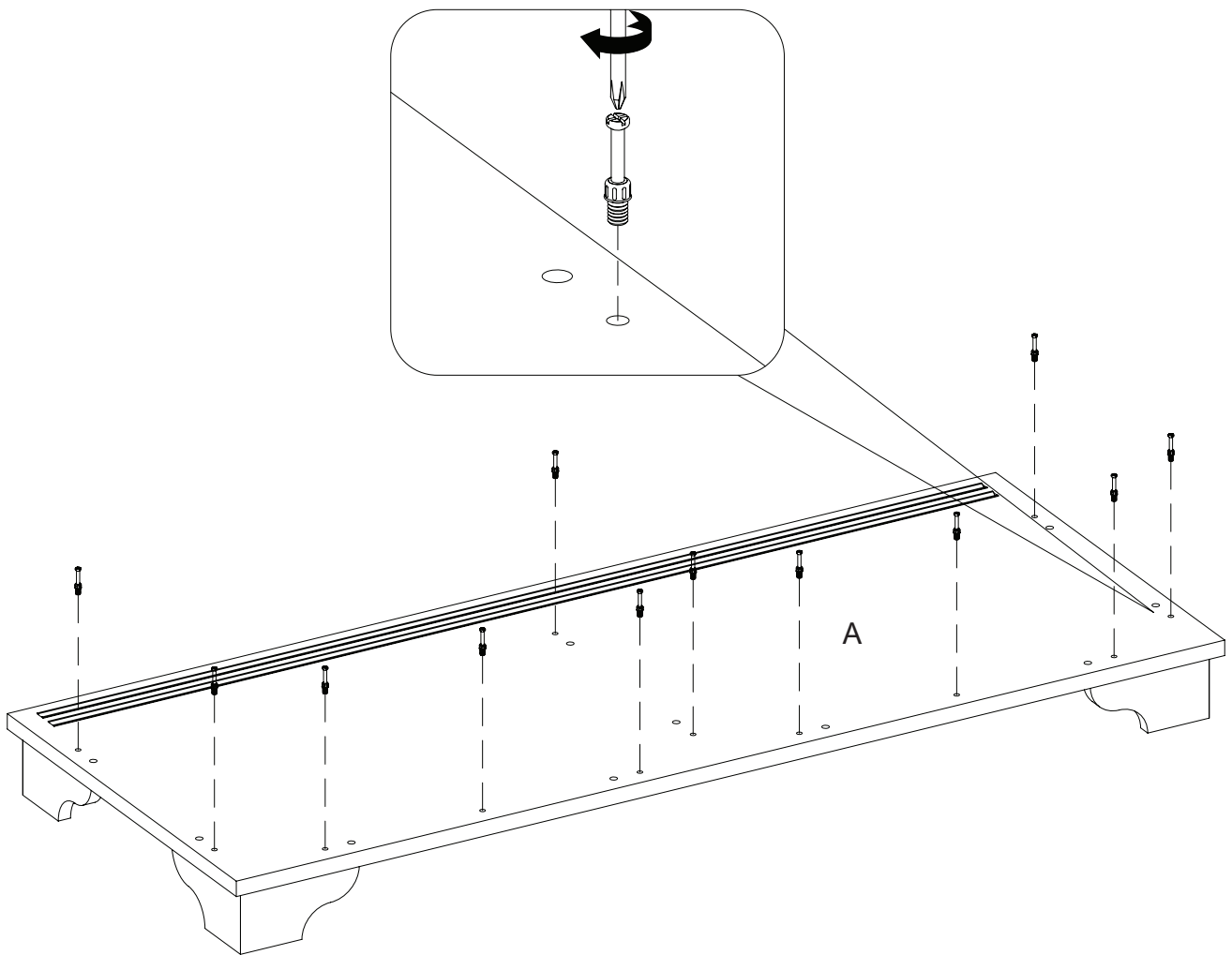

BB

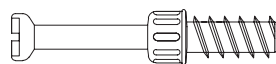

[x12]

# Step 11

Next, align the base panel (A) with the pre-drilled holes in the assembled unit and attach the base panel (A) to the assembled unit as shown. Then, insert and secure the base panel (A) using the cam locks (EE) as shown.

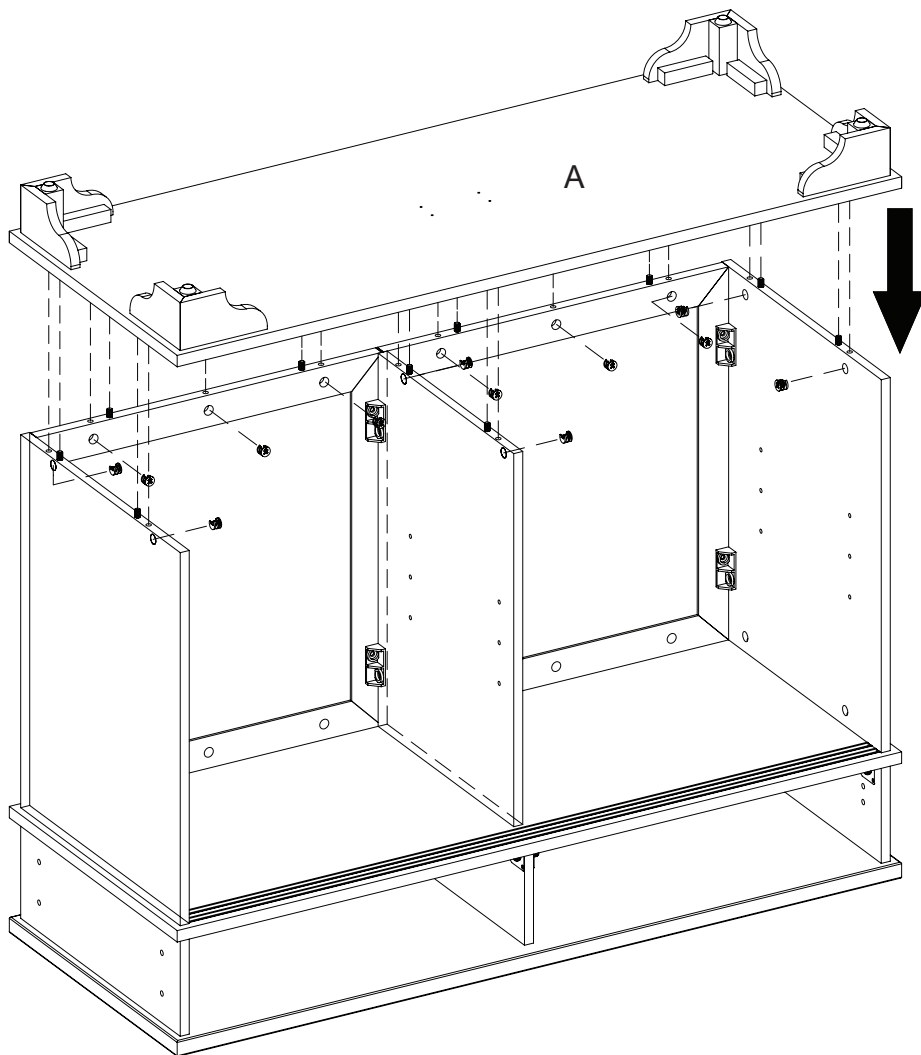
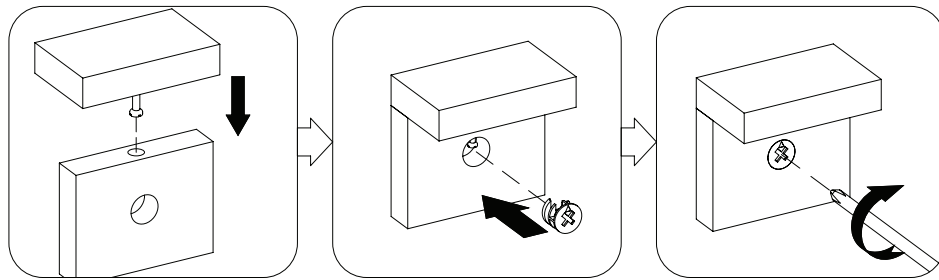

EE



[x12]

# Step 12

Attach the plastic covers (FF) over the cam locks holes as shown.

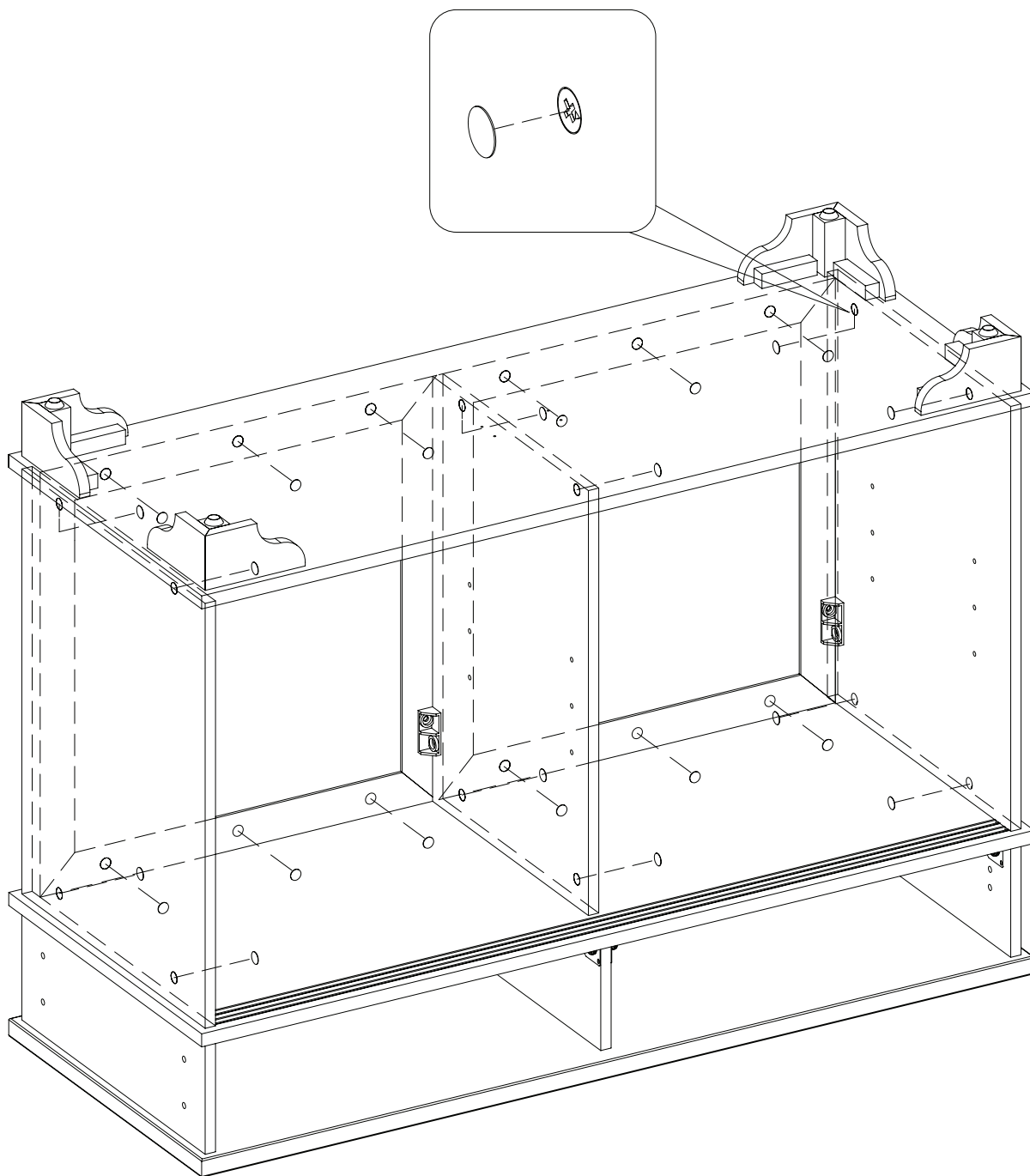

FF



[x24]

# Step 13

Align the center support leg (I) with the pre-drilled holes in the assembled unit as shown and then secure using the screws (GG).

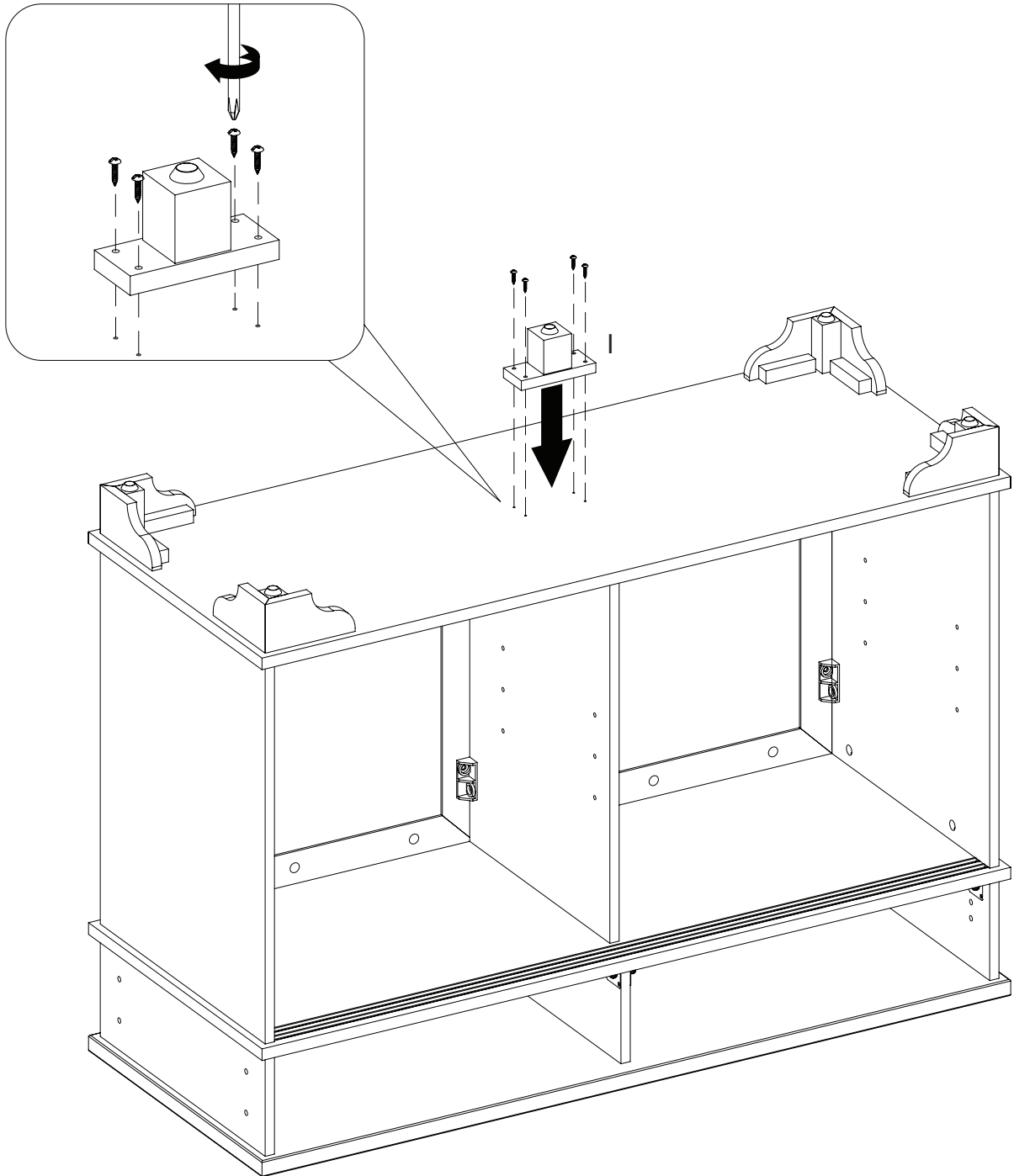

GG

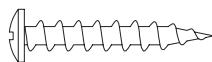

[x4]

# Step 14

Now it's time to attach the sliding doors. With help, turn the assembled unit right-side up. Then, align the bottom of the right door (K) to the tracks of the assembled unit as shown. Please take care to note the correct track placement in the image.

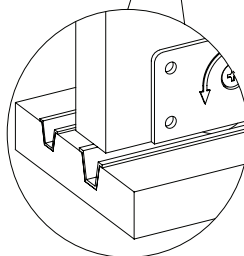
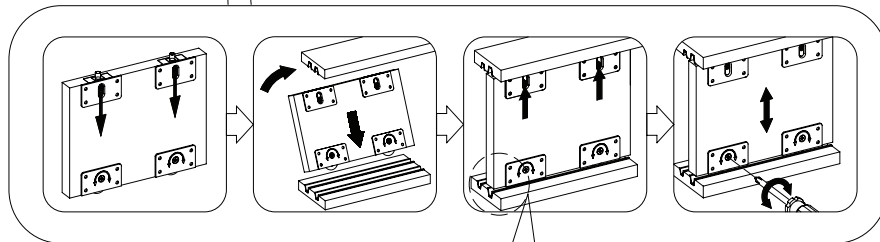
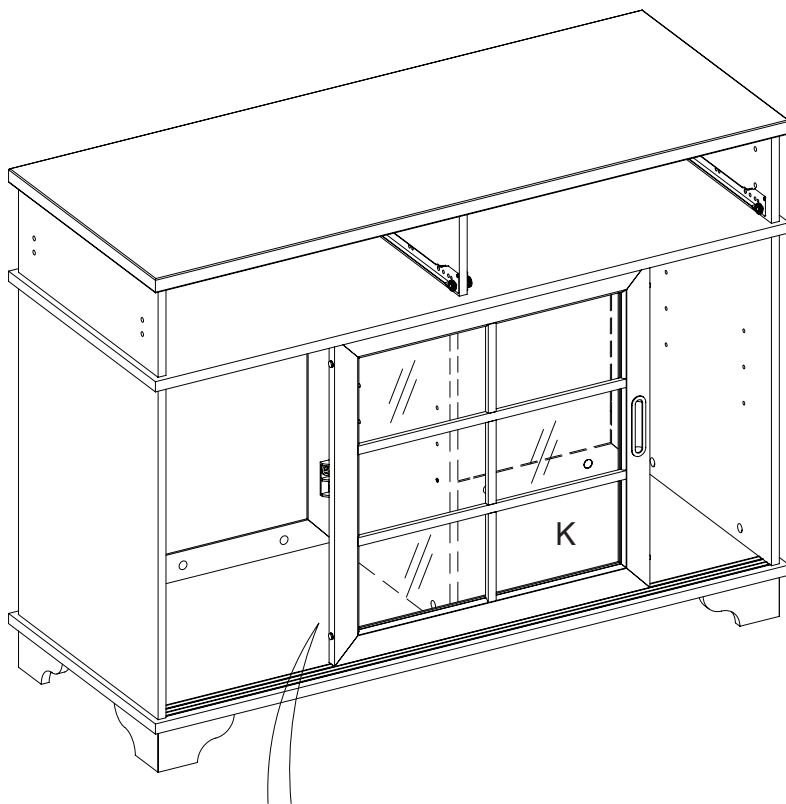

# Step 15

Repeat the same process in step 14 with the left door. Please take care to note the correct track placement by placing each door in the track as it looks in the image.

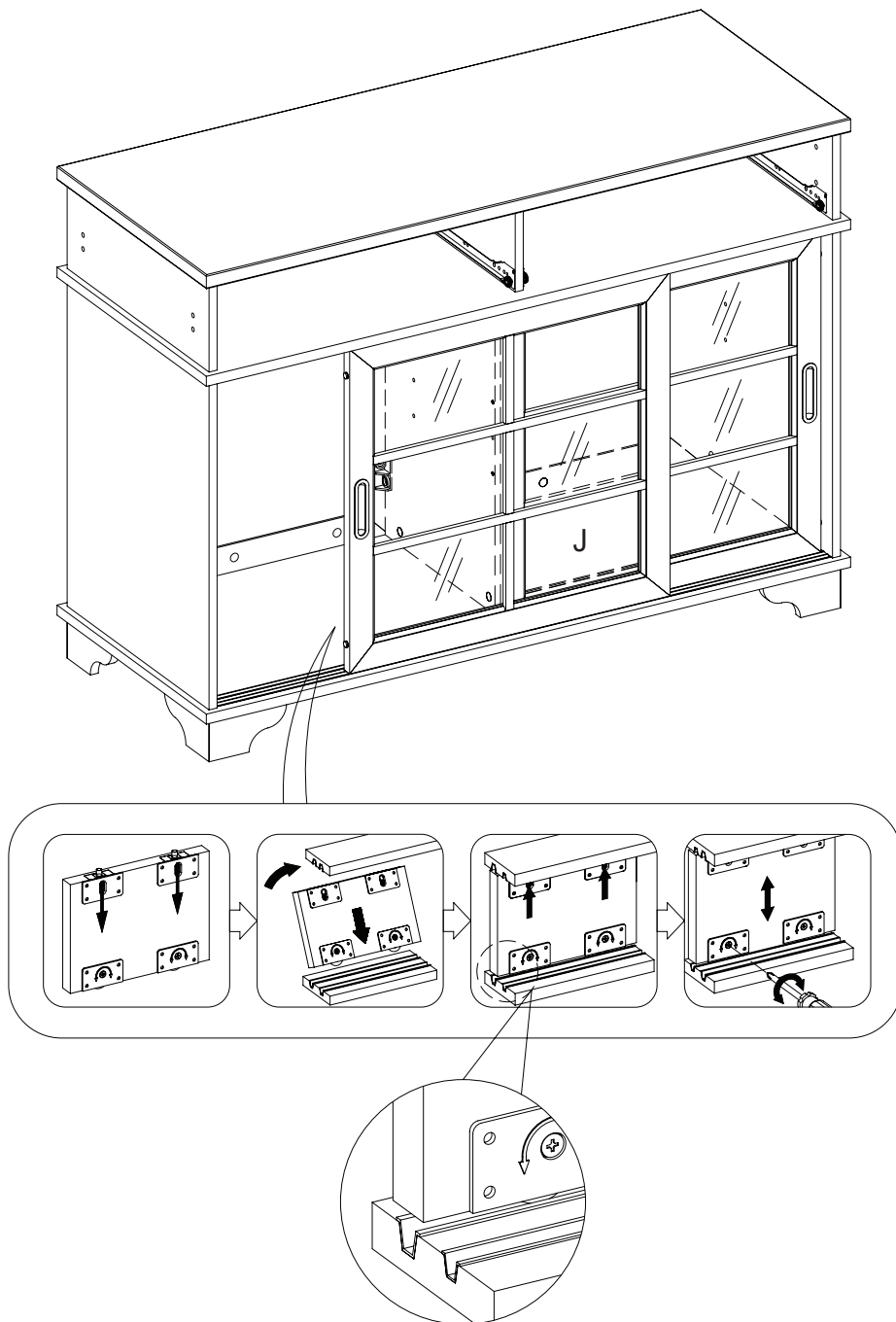

# Step 16

Now we are going to attach the shelf. The best part is that you can adjust the shelf height whenever you want. First, slide all the doors to one side so you have enough room. Then, insert the shelf pins (HH) into the holes on each side before tilting the shelf (L) into place.

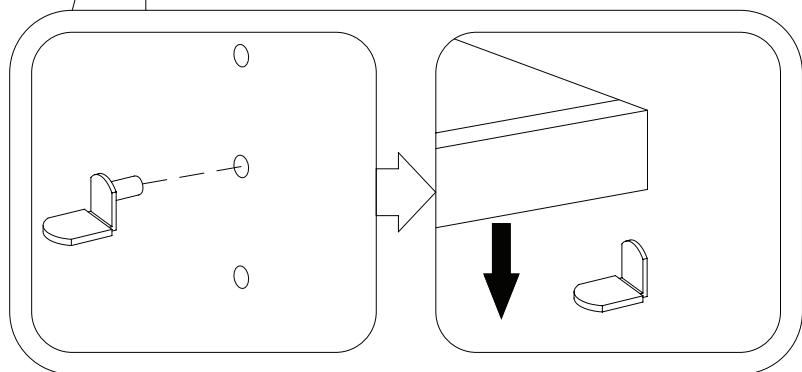
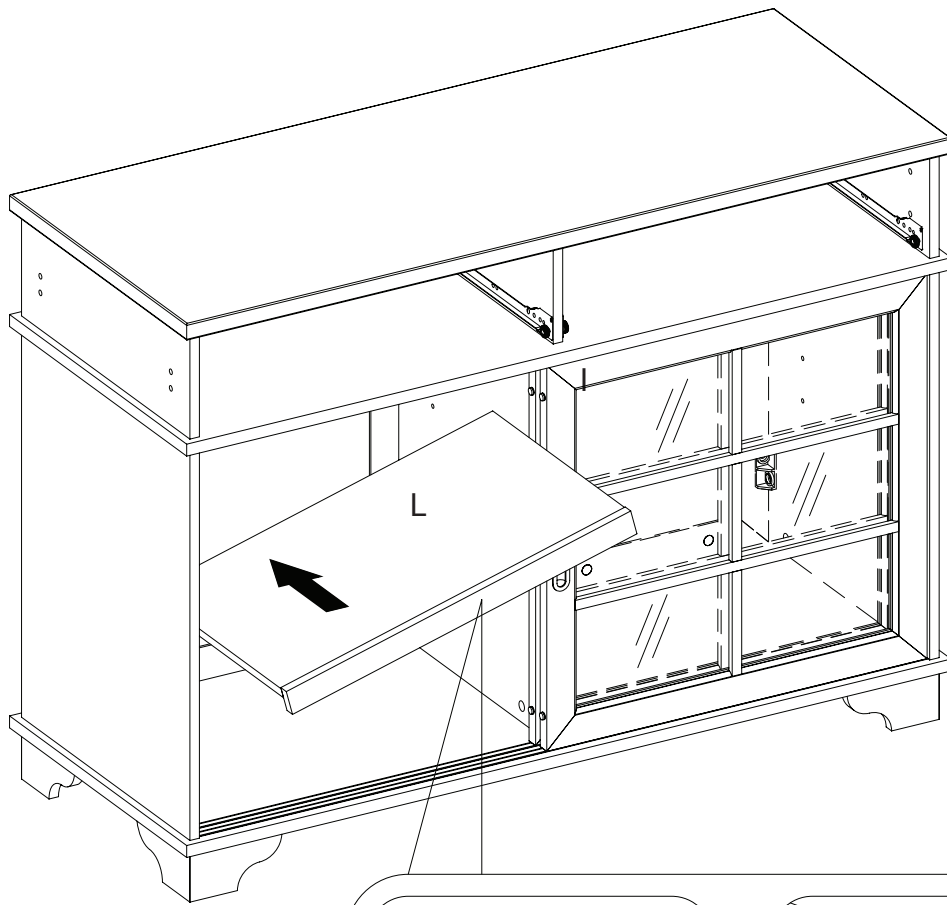

HH

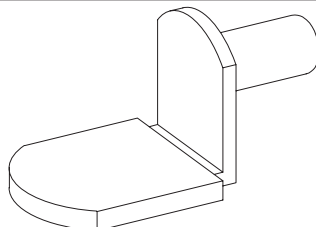

[x4]

# Step 17

Now, repeat the previous step 16 for the other side.

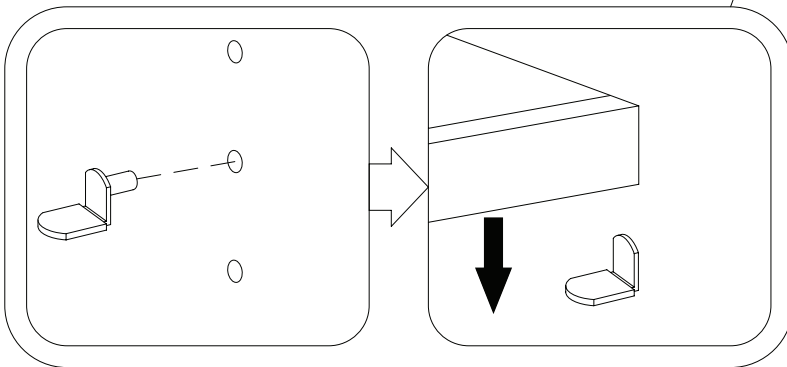
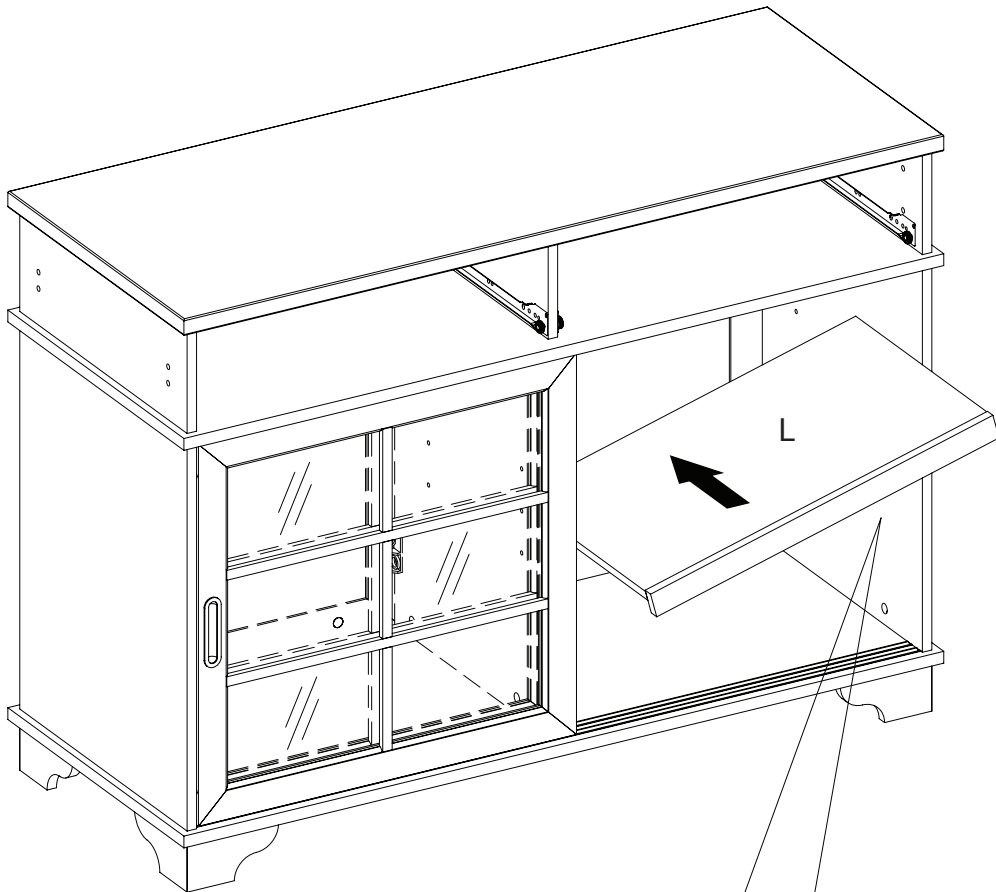

HH

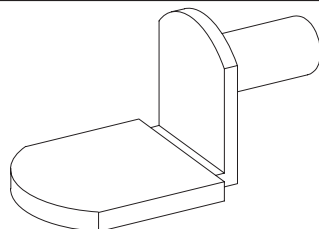

[x4]

# Step 18

Now, it is time to install the towel bar. Align the support rail (N) to the pre-drilled holes in the towel bar holder (M) as shown. Then, holding the towel bar in place on the left side, insert the bolt (II) through the hole and make sure the washer (JJ) is touching the wall and the spring washer (KK) is between the washer (JJ) and the bolt (II). You can secure the towel bar to the island using the Hexagon Wrench (LL) provided.

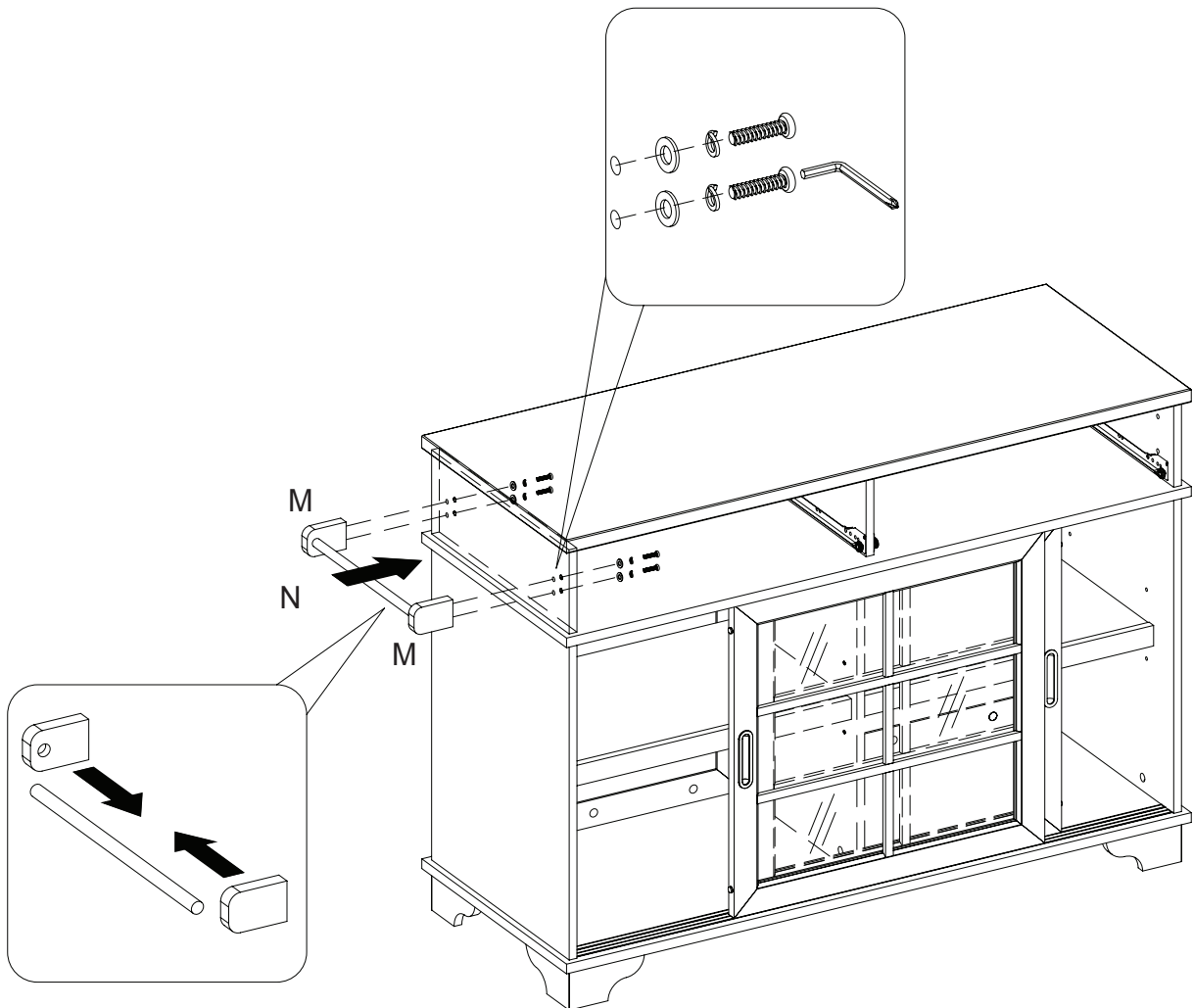

II

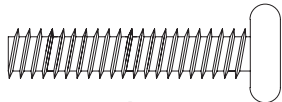

[x4]

JJ

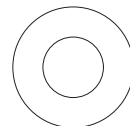

[x4]

KK



[x4]

LL

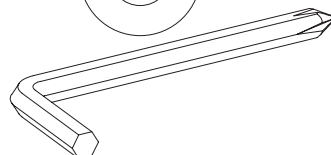

# Step 19

Insert and secure the cam bolts (BB) into the wine left side panel (O) and wine right side panel (H) as shown.

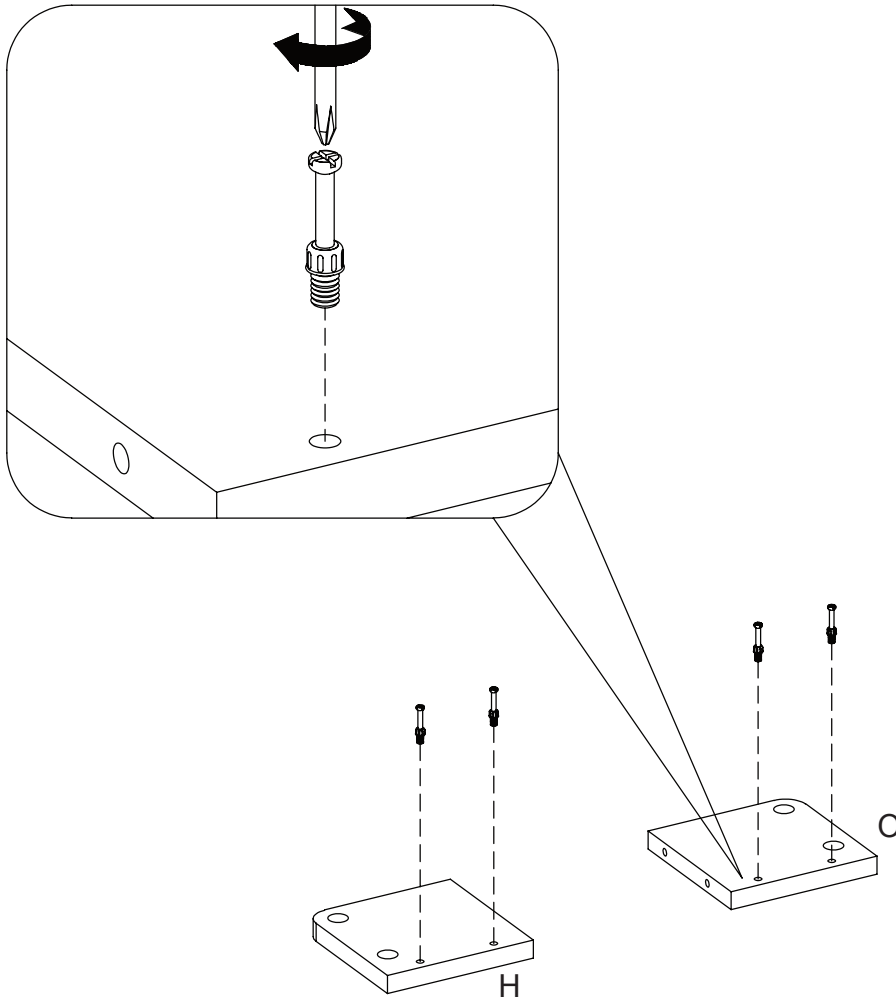

BB

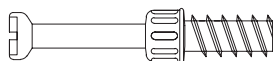

[x4]

# Step 20

Align the wine right side panel (H) with the pre-drilled holes in the wine bottom panel (P) and attach wine right side panel (H) to the wine bottom panel (P) as shown. Then, insert and secure the wine right side panel (H) using the cam locks (EE) as shown.

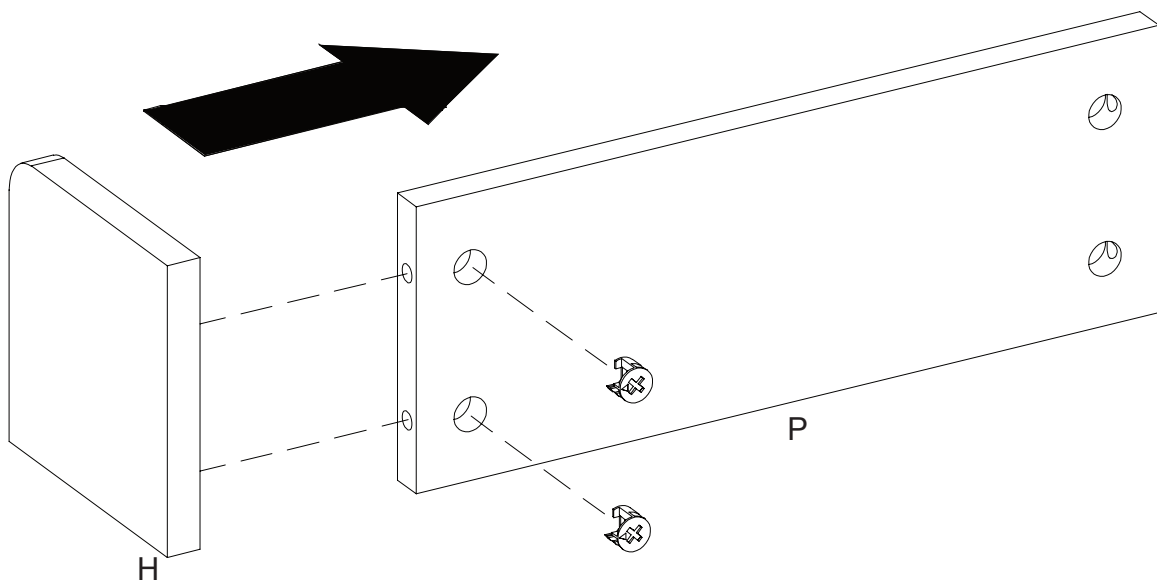
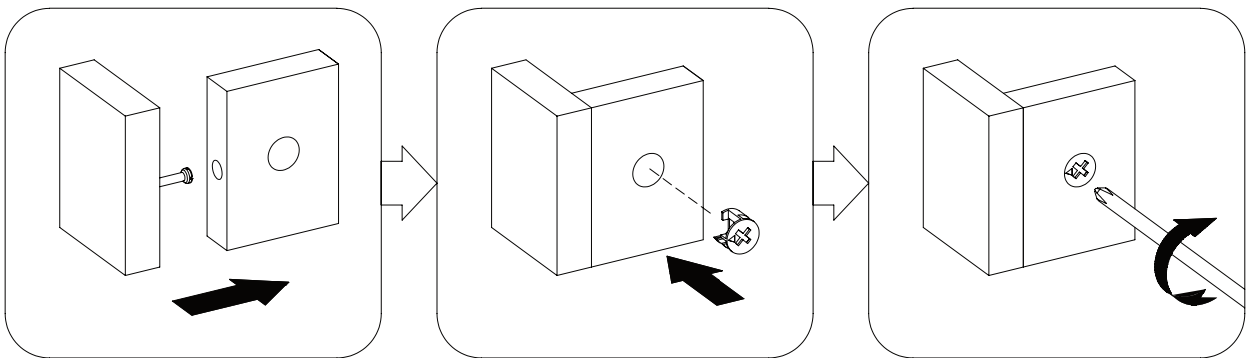

EE



[x2]

# Step 21

Align Support Rail (N) with the pre-drilled holes in the assembled unit as shown.

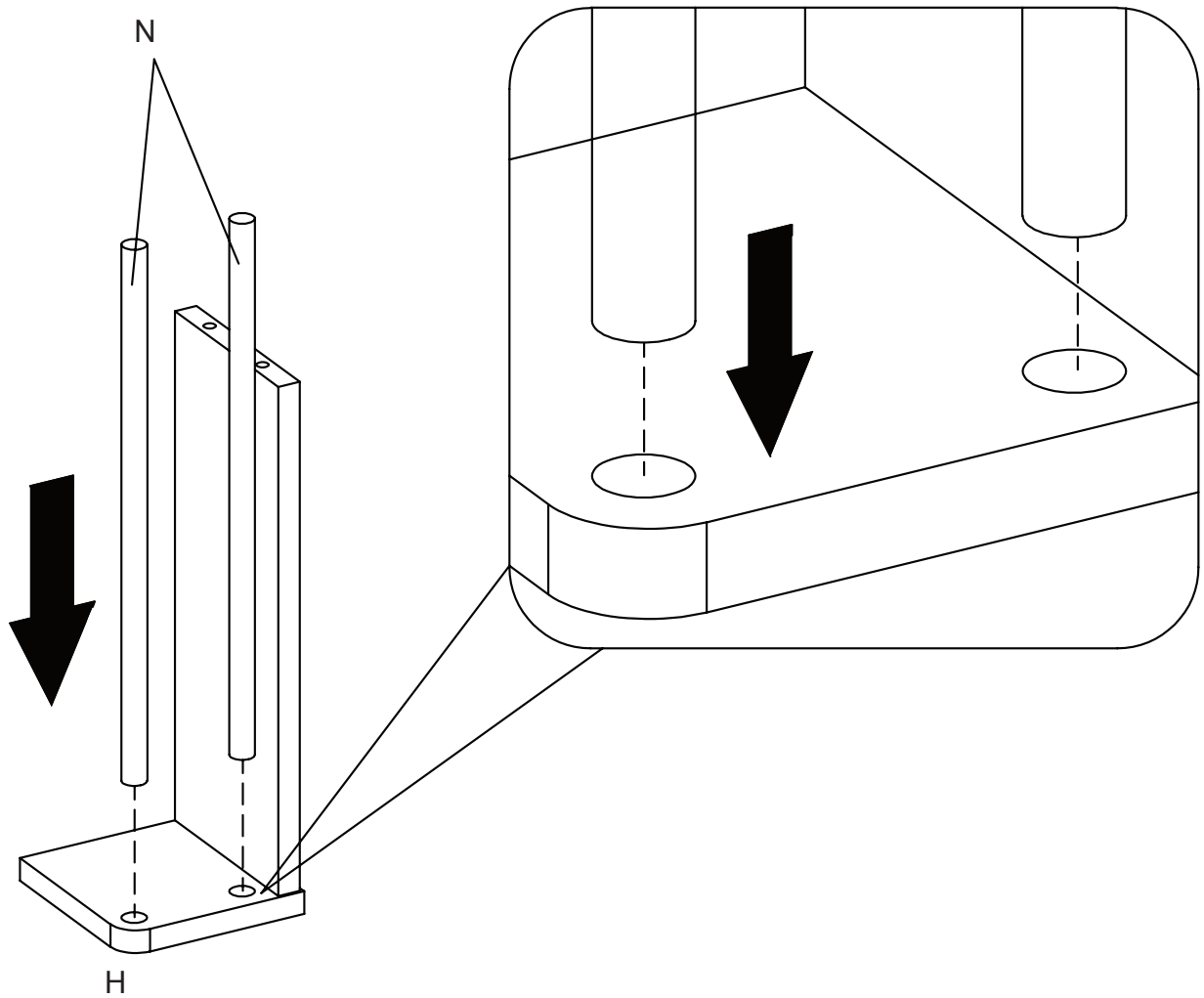

# Step 22

Align Support Rail (N) with the pre-drilled holes in wine left side panel (O) as shown. Then, insert and secure the wine left side panel (O) using the cam locks (EE) as shown.

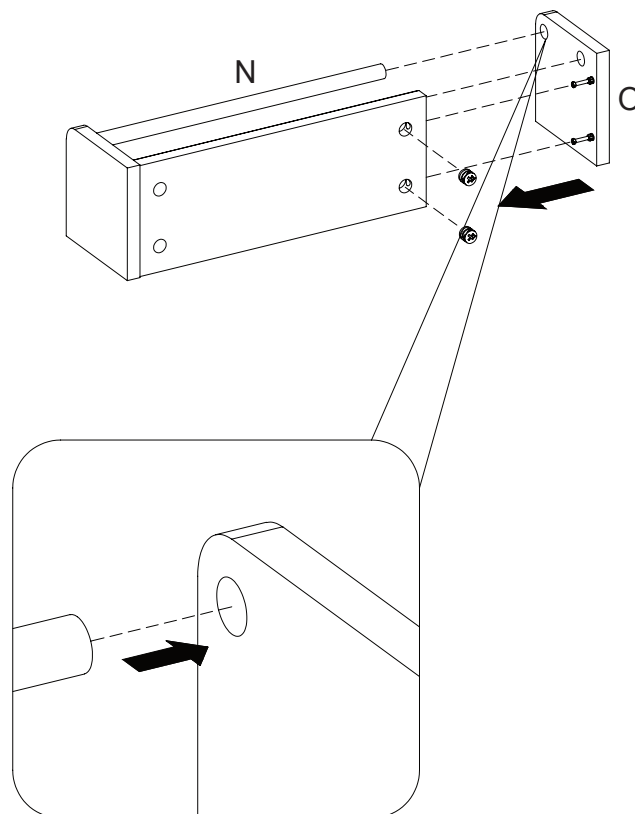
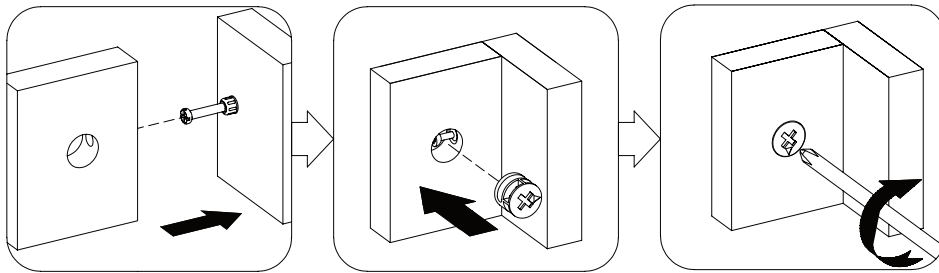

EE



[x2]

# Step 23

Let's repeat a similar process for the wine shelf. Remember to place the washer (JJ) against the wall first, followed then by the spring washer (KK), and then move the bolt through the hole just like the image below. Then tighten the bolt (II) with the provided Hexagon Wrench (LL).

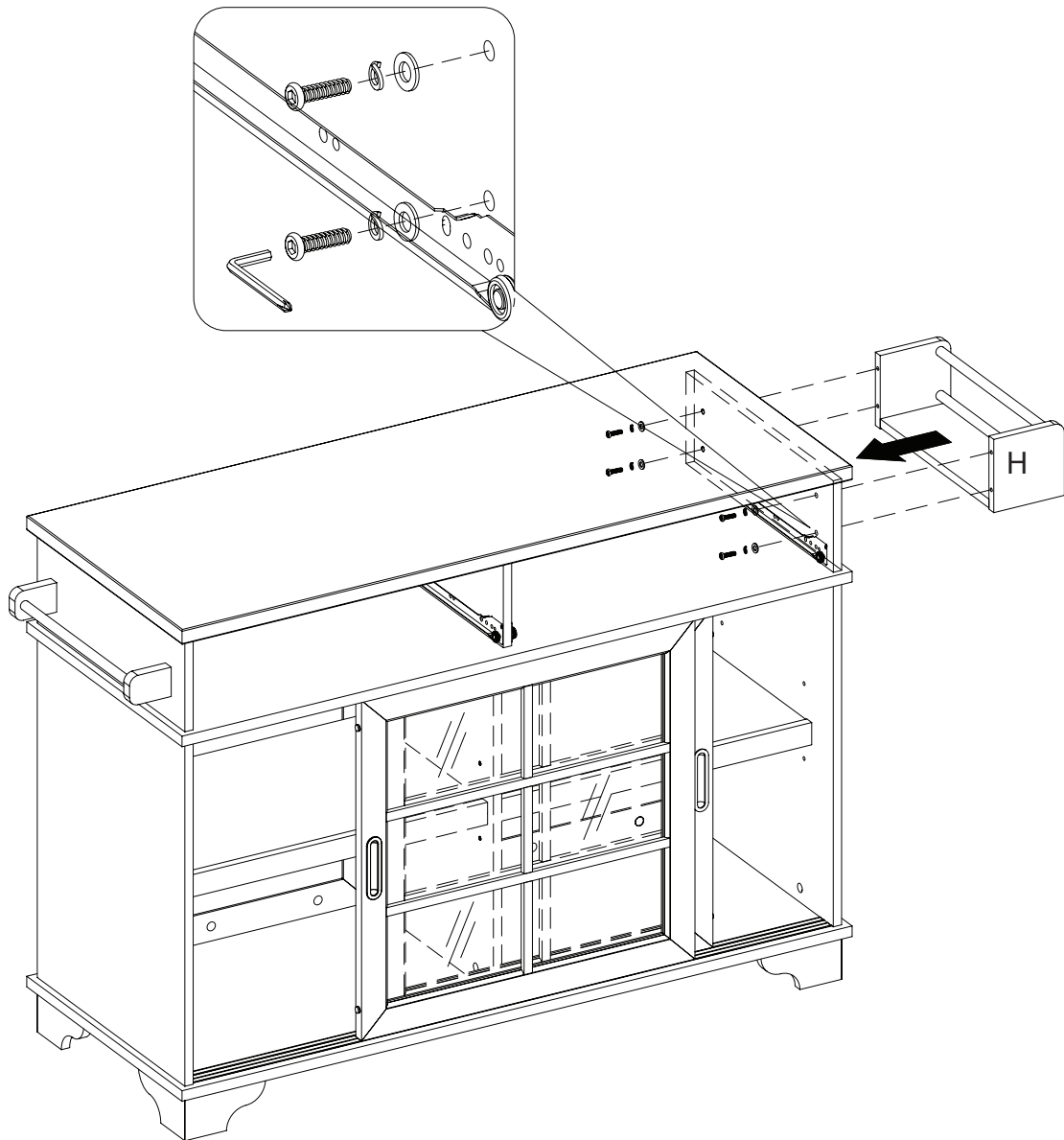

II

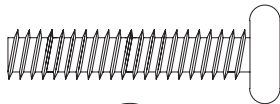

[x4]

JJ

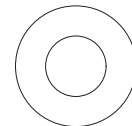

[x4]

KK



[x4]

LL

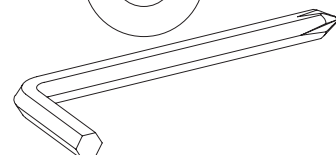

# Step 24

Next, slide the drawers back into the island.

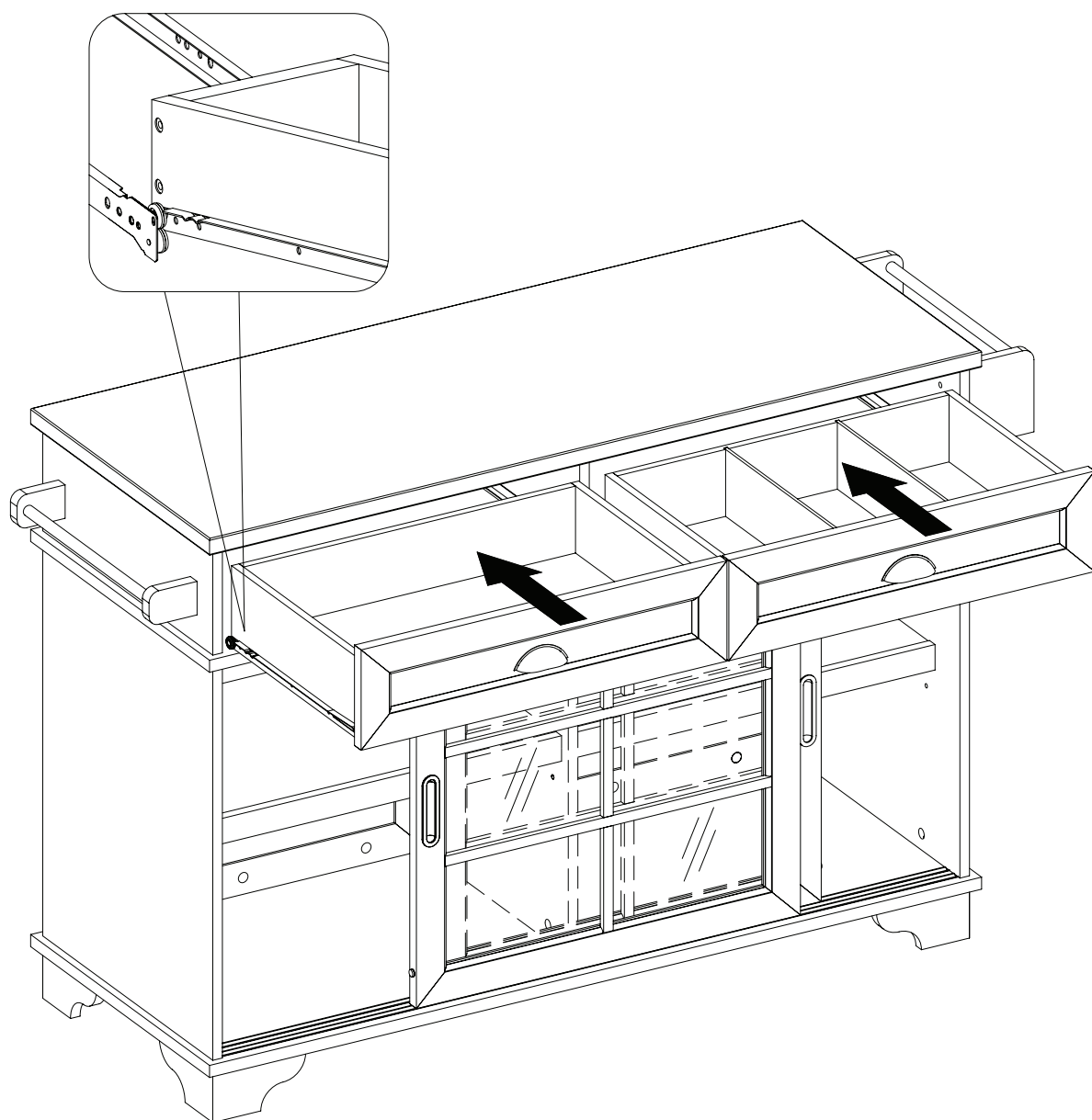

# Step 25

Last Step! If needed, adjust the floor levelers to make sure your kitchen island is sturdy.

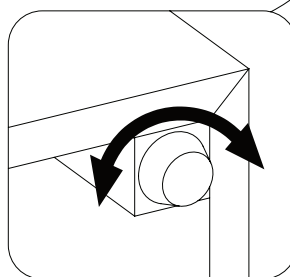
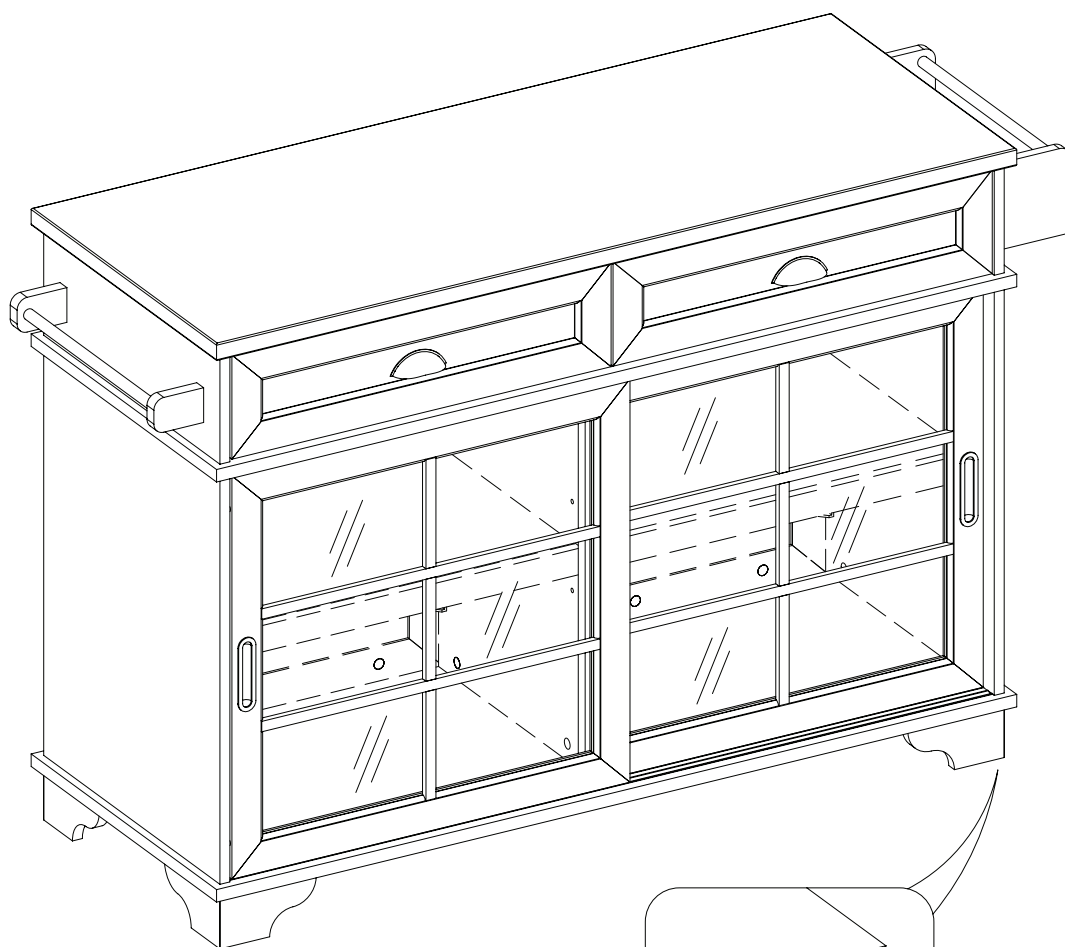

# Final Assembly

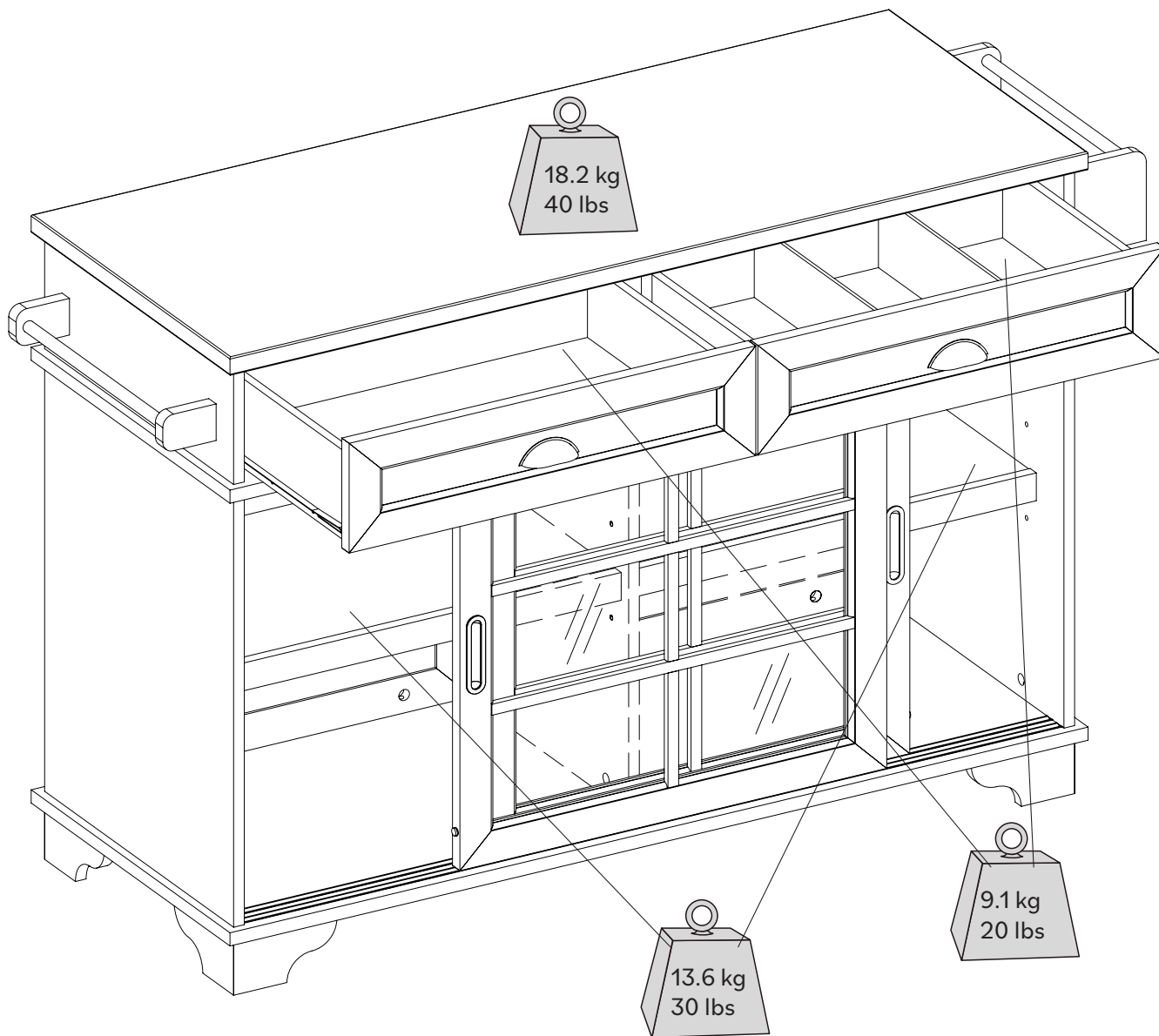

**Congratulations on your new piece of furniture!**

We would love to hear about it and see it.  
Please leave us a review or post a picture.