

NESTING END TABLE



ASSEMBLY INSTRUCTIONS

We have designed our furniture with you, the customer in mind. Our clear, easy to follow, step by step instructions will guide you through the project from start to finish. feel confident that this will be a fun and rewarding project. The final product will be a quality piece of furniture that will go together smoothly and give you years of enjoyment.







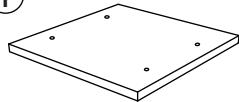
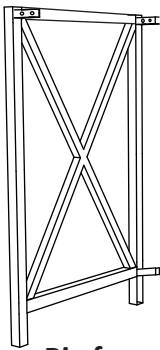

Please do not return to the store

Broken or missing parts?

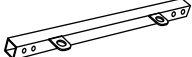
Need help with assembly?

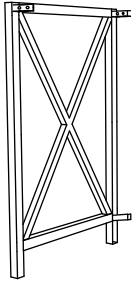
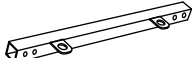
Accessories list

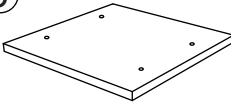

A  Allen screw (32pcs)	1  Big top panel (1pc)	2  Big frame (2pcs)	4  Big bottom metal tube (1pc)
B  Allen wrench (1pc)	3  Big top metal tube (2pcs)		
C  Foot (8pcs)	6  Frame (2pcs)	7  Top metal tube (2pcs)	8  Bottom metal tube (1pc)
5  Top panel (1pc)			

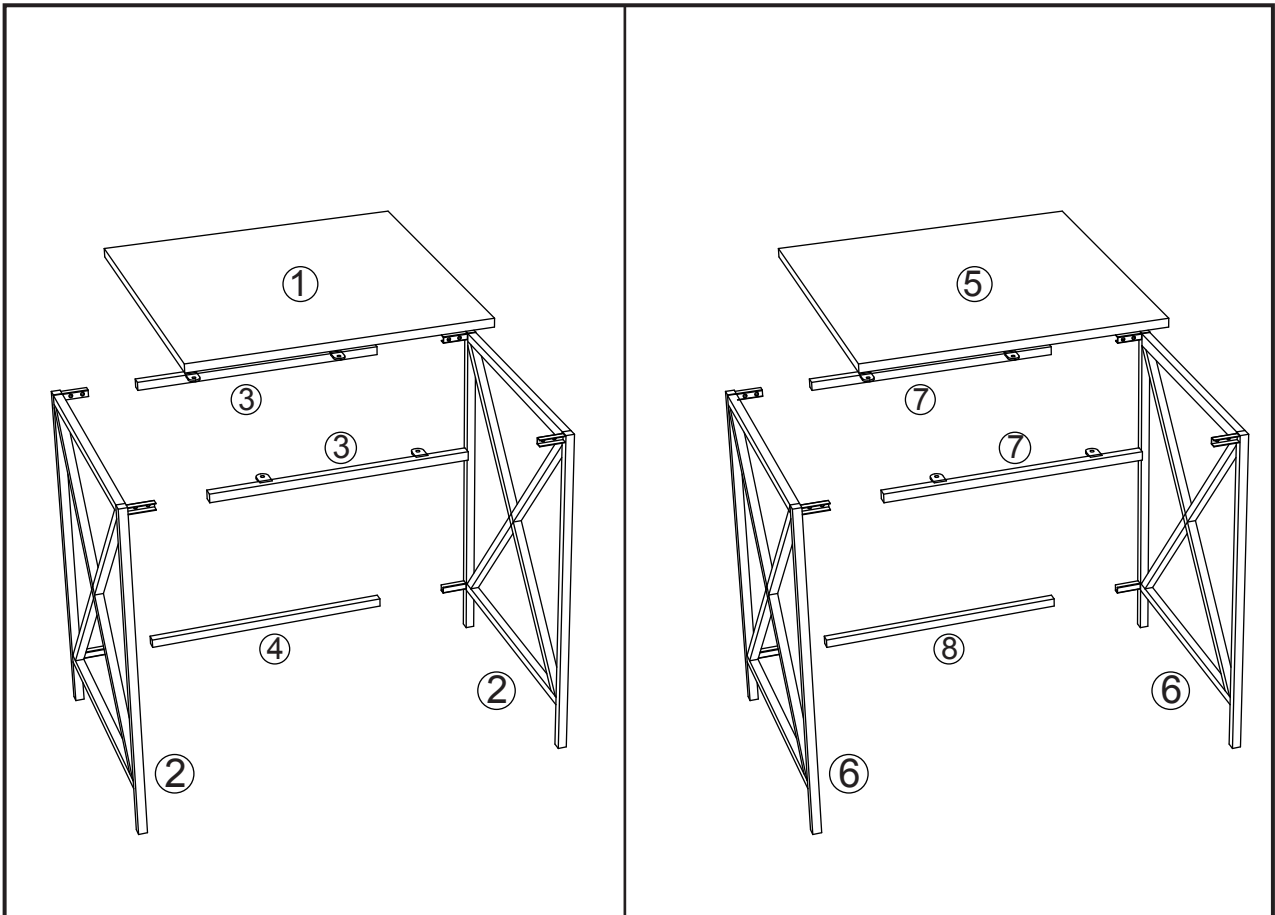
Exploded Views



Step 1

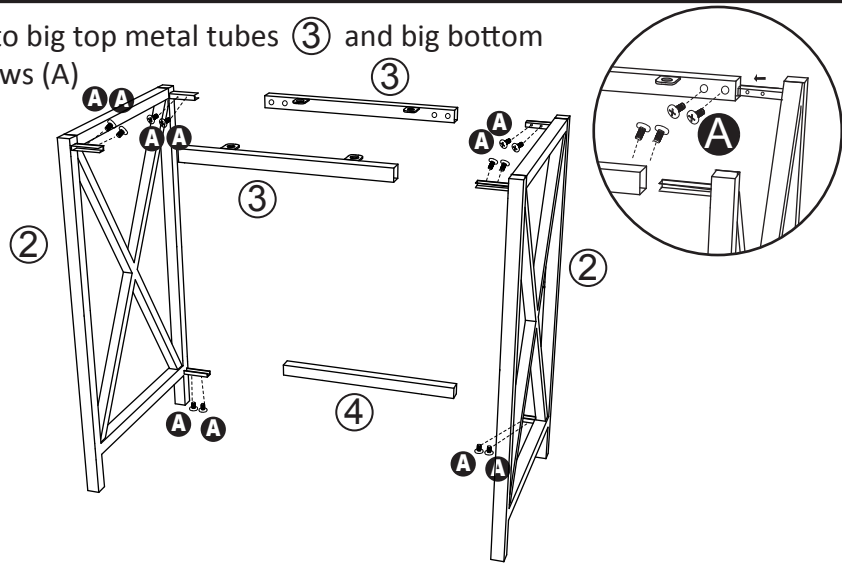

1. Connect the big frames (2) to big top metal tubes (3) and big bottom metal tube (4) using allen screws (A) and allen wrench (B).

A	
Allen screw (12pcs)	
B	
Allen wrench (1pc)	



Step 2

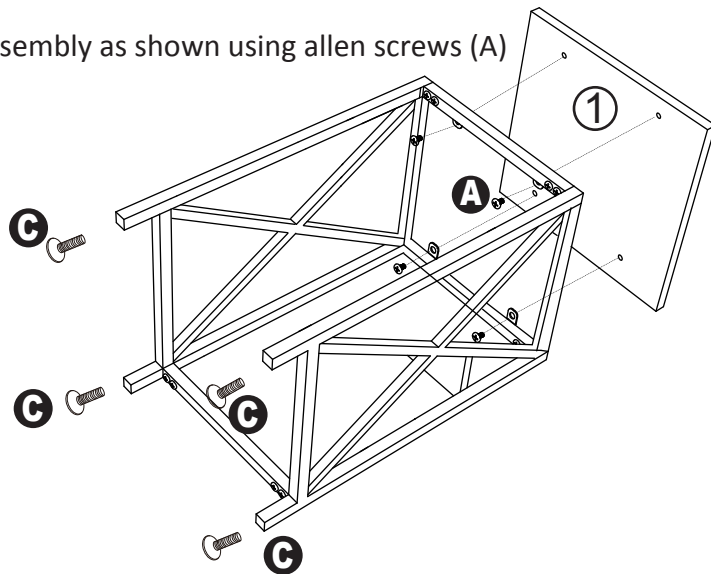

1. Connect big top panel (1) to assembly as shown using allen screws (A) and allen wrench (B).
2. Screw feet (C) into unit.

A	
Allen screw (4pcs)	
B	
Allen wrench (1pc)	
C	
Foot (4pcs)	



Step 3

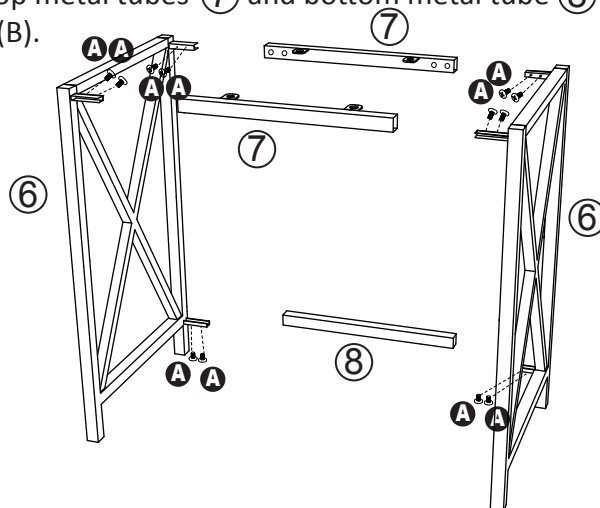

1. Connect the frames (6) to top metal tubes (7) and bottom metal tube (8) using allen screws (A) and allen wrench (B).

A	
Allen Screw (12pcs)	
B	
Allen wrench (1pc)	



Step 4

1. Connect top panel ⑤ to assembly as shown using allen screws (A) and allen wrench (B).
2. Screw feet (C) into unit.

A	
Allen Screw (4pcs)	
B	
Allen wrench (1pc)	
C	
Foot (4pcs)	

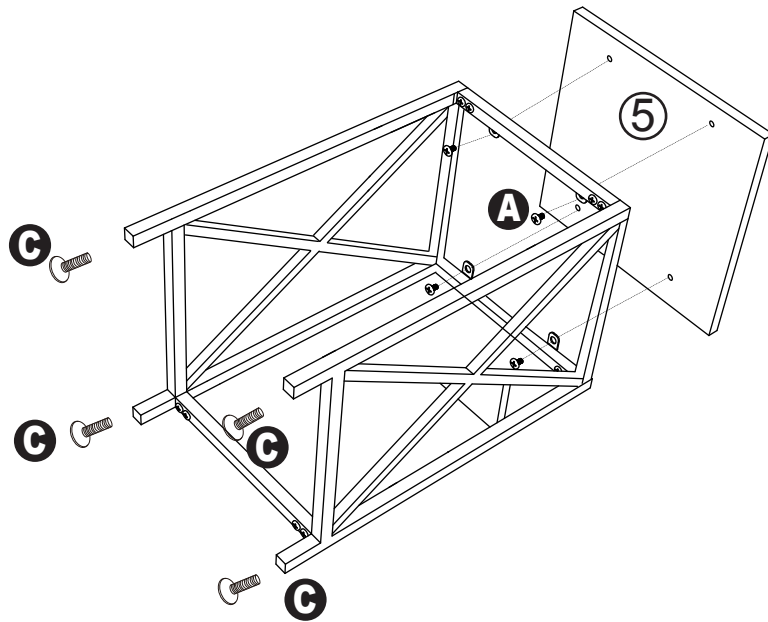

Step 5

1. Finish and enjoy!

