

Assembly Guide

Tip!

Do check for all the components and screws listed in this guide before putting things together. If any part is missing, contact us for the missing part.

Return Policy

Your satisfaction is our top priority. If our product fails to satisfy you, please let us know how we can make things right for you. Our trained customer care team can handle most concerns and assist you with any questions you may have. Simply shoot them a message with your order number and question. To be eligible for a full-refund return, the item must be in pristine condition, in the original packaging, with all of the shipped components intact and not yet assembled, and with the item's unique proof of purchase.

Trouble shooting:

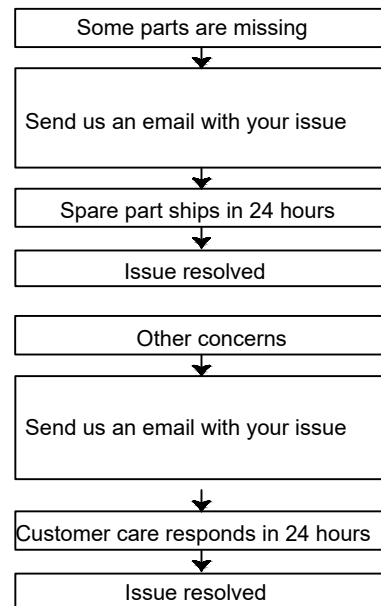

We run our own manufacturer, so rest assured about the quality consistency.

Montageanleitung

Tip!

ÜBERPRÜFEN Sie alle in dieser Anleitung aufgeführten Komponenten und Schrauben, bevor Sie die Bauteile zusammenbauen. Sollte ein Bauteil fehlen, kontaktieren Sie uns um Ersatz zu erhalten.

Rückgaberrichtlinie

Ihre Zufriedenheit ist unsere oberste Priorität. Wenn Sie mit unserem Produkt nicht zufrieden sind, lassen Sie uns bitte wissen, wie wir die Angelegenheit für Sie in Ordnung bringen können. Unser geschultes Kundenbetreuer kann die meisten Anliegen lösen und unter Sie bei allen Ihren Fragen. Senden Sie uns einfach eine Nachricht mit Ihrer Bestellnummer und Ihrer Frage. Um eine volle Rückerstattung zu erhalten, muss der Artikel in einwandfreiem Zustand sein und sich in der Originalverpackung mit allen gelieferten und noch nicht zusammengebaute Komponenten befinden. Zudem wird der eindeutige Kaufnachweis des Artikels.

Problemlösung:

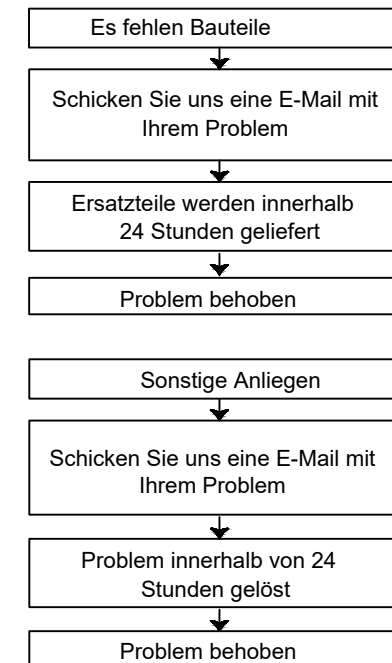

Wir stellen unsere Artikel selbst her, sodass Sie sich auf gleichbleibende Qualität verlassen können.

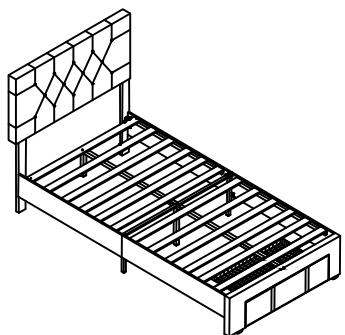

Item Description: Bed Frame

Model NO: _____

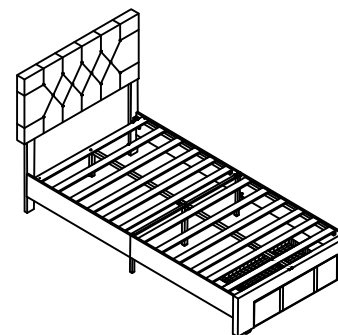

Item Description: Bettrahmen

Model NO: _____

Guía de montaje

Consejo I

Verifique todos los componentes y tornillos. Enumerados en esta guía antes de poner las cosas juntos. Si falta alguna pieza, contáctanos por los desaparecidos parte.

Política de devoluciones

Su satisfacción es nuestra máxima prioridad. Si nuestro el producto no le satisface, háganoslo saber. CÓMO podemos hacer las cosas bien para usted. Nuestro equipo de atención al cliente capacitado puede manejar la mayoría inquietudes y ayudarle con cualquier pregunta es posible que tengas. Simplemente envíales un mensaje con su número de pedido y pregunta. Ser elegible para una devolución con reembolso completo, el artículo debe estar en impecable estado, en el embalaje original, con todos los componentes enviados intactos y aún no ensamblado y con la característica única del artículo. Comprobante de compra.

Solución de problemas:

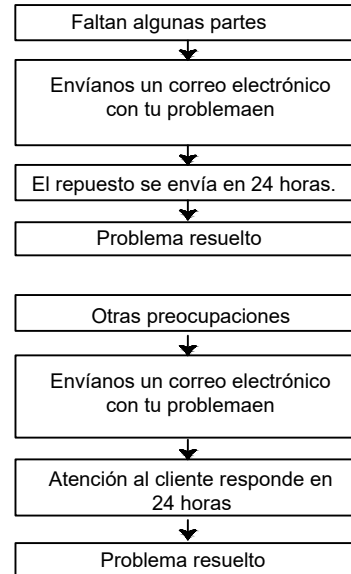

Dirigimos nuestro propio fabricante, así que descansa. Asegurado sobre la consistencia de la calidad

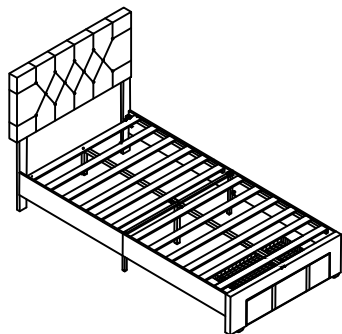

Descripción del artículo: Marco de la cama

Modelo NO: _____

CAUTION!



ACHTUNG!



ATTENTION !



CAUTELA !







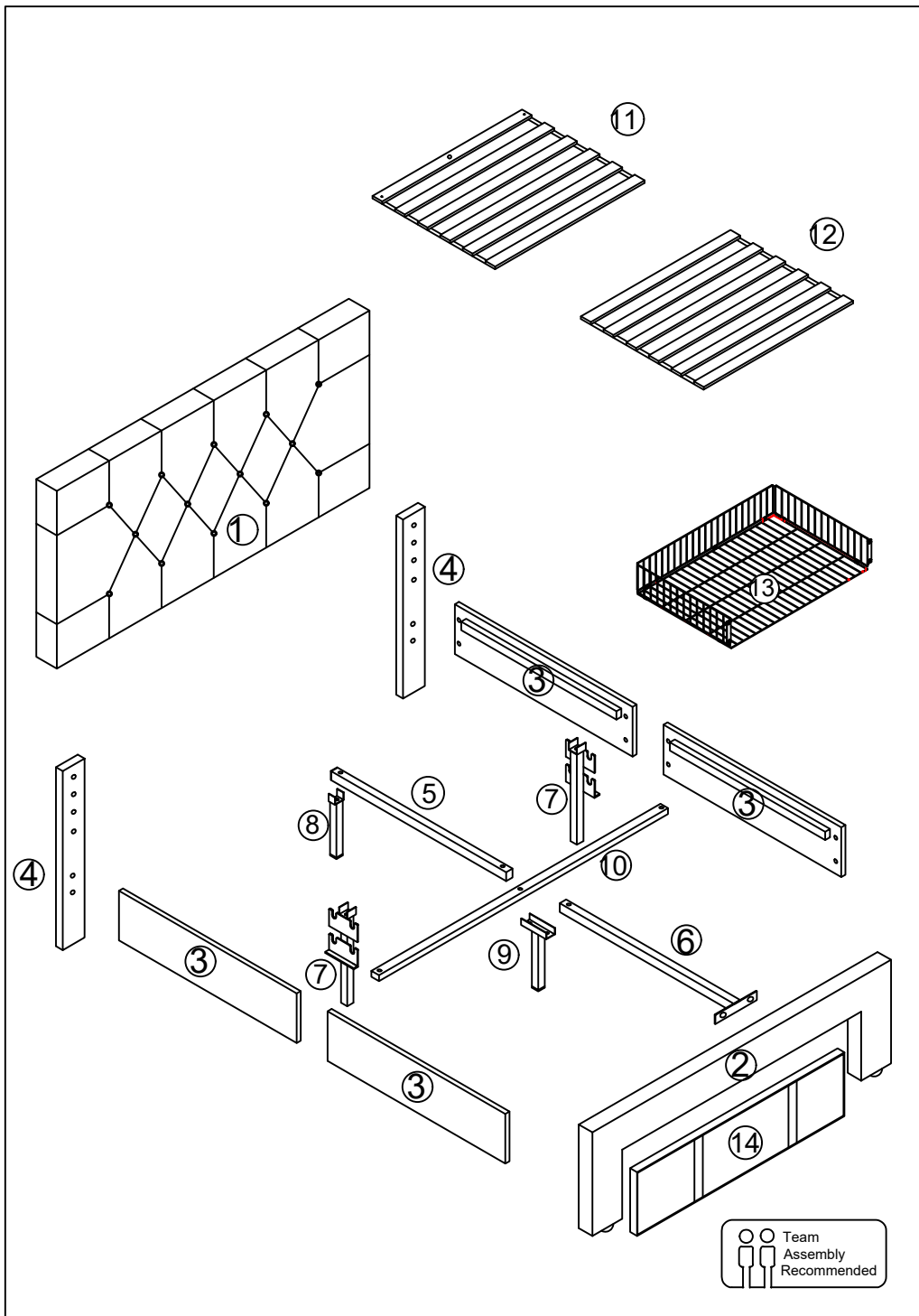



PRECAUCIÓN !



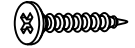
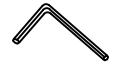
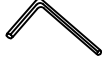

Components / Bauteile / Composants / Componenti / Componentes					
①		1pc	②		1pc
③		4pcs	④		2pcs
⑤		1pc	⑥		1pc
⑦		2pcs	⑧		1pc
⑨		1pc	⑩		1pc
⑪		1pc	⑫		1pc
⑬		1pc	⑭		1pc

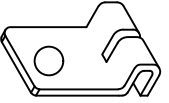
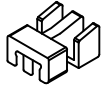
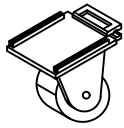
(A)	 Bolt M6 x 15	5	(B)	 Bolt M8 x 16	16+1
(C)	 Bolt M8 x 25	14+1	(D)	 Bolt M8 x 45	7+1
(E)	 Spacer	4	(F)	 SCREW M4*25	2
(G)	 Allen Key M5	1	(H)	 Allen Key M4	1

(I)	 Angle iron	2	(J)	 Angle iron	2
(K)	 Hook	1	(L)	 Plastic Buckles	2
(M)	 Wheel	5	(O)	 Plastic Buckles	2

Step 1.1



- Each pair of holes corresponds to a mattress thickness as shown below.
- ★ Chaque paire de trous correspond à une épaisseur de matelas, comme indiqué ci-dessous.
- ▲ Jedes Paar Löcher entspricht einer Matratzenstärke, wie unten gezeigt.
- Ogni coppia di fori corrisponde ad uno spessore del materasso come mostrato di seguito.
- ✿ Cada par de agujeros corresponde al grosor del colchón, como se muestra a continuación.

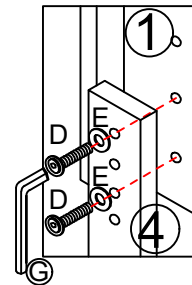
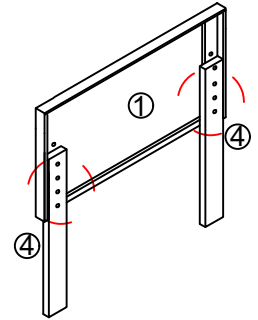

- Use these holes to fit a 12 inch thick mattress (45.6 inch tall overall)
- ★ Utilisez ces trous pour s'adapter à un matelas de 12 Centimètres d'épaisseur (45.6 Centimètres de hauteur totale)
- ▲ Jedes Paar Löcher entspricht einer Matratzendicke. Um eine 12-Zentimeter-Matratze anzupassen (Insgesamt 45.6 Zentimeter)
- Utilizzare questi fori per adattarsi a un materasso spesso 12 pollici (alto complessivamente 45.6 pollici)
- ✿ Utilice estos agujeros para adaptarse a un colchón de 12 pulgadas de grosor (45.6 pulgadas de alto en total)

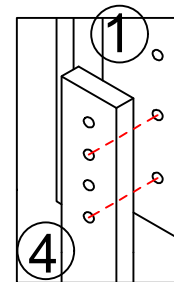

- Use these holes to fit a 10 inch thick mattress (43.6 inch tall overall)
- ★ Utilisez ces trous pour s'adapter à un matelas de 10 Centimètres d'épaisseur (43.6 Centimètres de hauteur totale)
- ▲ Jedes Paar Löcher entspricht einer Matratzendicke. Um eine 10-Zentimeter-Matratze anzupassen (Insgesamt 43.6 Zentimeter)
- Utilizzare questi fori per adattarsi a un materasso spesso 10 pollici (alto complessivamente 43.6 pollici)
- ✿ Utilice estos agujeros para adaptarse a un colchón de 10 pulgadas de grosor (43.6 pulgadas de alto en total)

Step 1.2

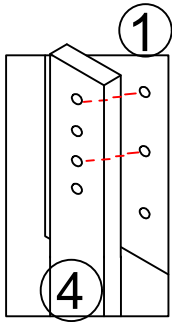



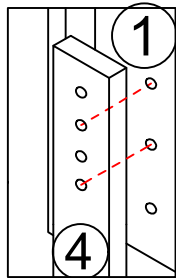

- Use these holes to fit a 8 inch thick mattress (41.6inch tall overall)
- ★ Utilisez ces trous pour s'adapter à un matelas de 8 Centimètres d'épaisseur (41.6 Centimètres de hauteur totale)
- ▲ Jedes Paar Löcher entspricht einer Matratzendicke. Um eine 8-Zentimeter-Matratze anzupassen (Insgesamt 41.6 Zentimeter)
- Utilizzare questi fori per adattarsi a un materasso spesso 8 pollici (alto complessivamente 41.6 pollici)
- ✱ Utilice estos agujeros para adaptarse a un colchón de 8 pulgadas de grosor (41.6 pulgadas de alto en total)



- Use these holes to fit a 6 inch thick mattress (39.6 inch tall overall)
- ★ Utilisez ces trous pour s'adapter à un matelas de 6 Centimètres d'épaisseur (39.6 Centimètres de hauteur totale)
- ▲ Jedes Paar Löcher entspricht einer Matratzendicke. Um eine 6-Zentimeter-Matratze anzupassen (Insgesamt 39.6 Zentimeter)
- Utilizzare questi fori per adattarsi a un materasso spesso 6 pollici (alto complessivamente 39.6 pollici)
- ✱ Utilice estos agujeros para adaptarse a un colchón de 6 pulgadas de grosor (39.6 pulgadas de alto en total)

Step 2

	B*8		J*2
	I*2		G*1

Tips:
Must Keep the Brackets
Lay Toward the Ground

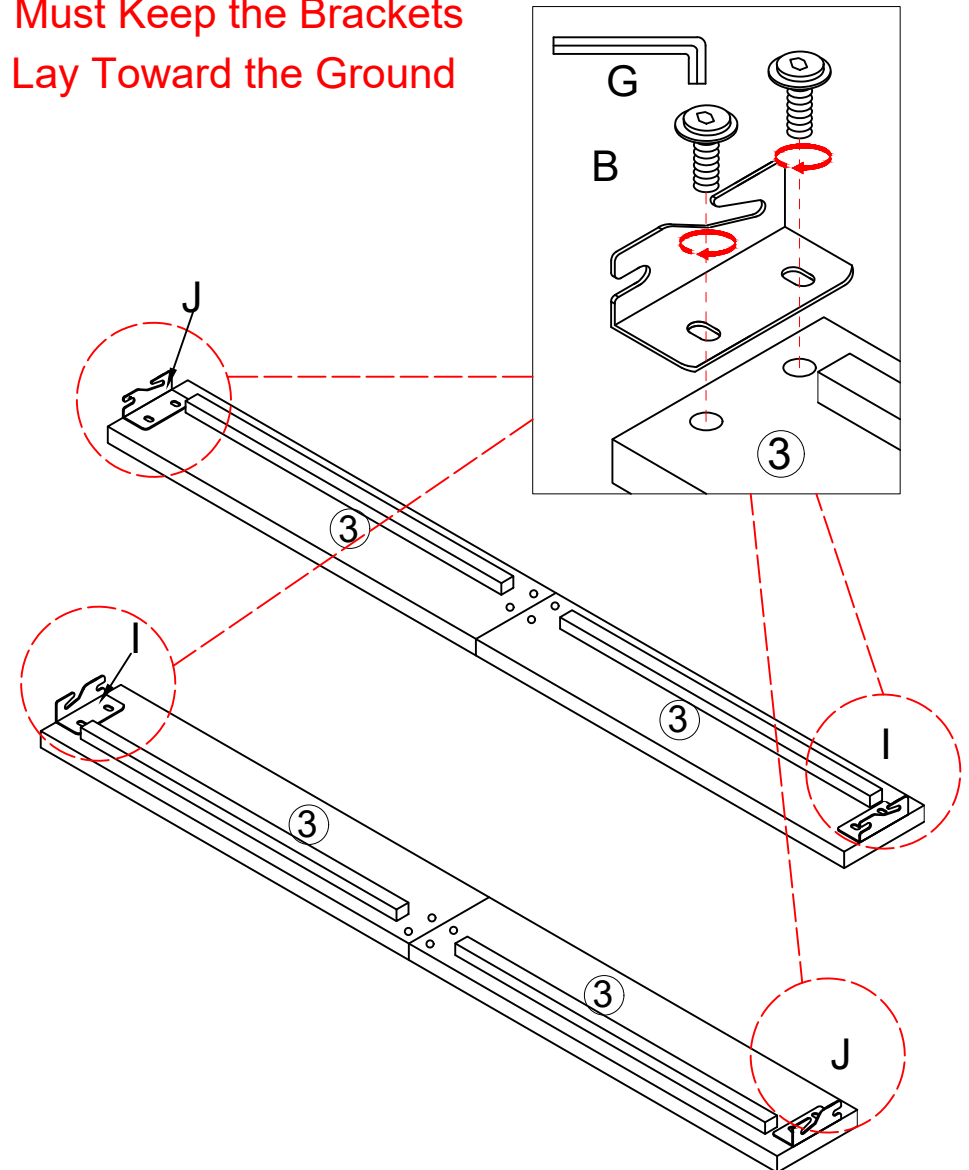

Step 3

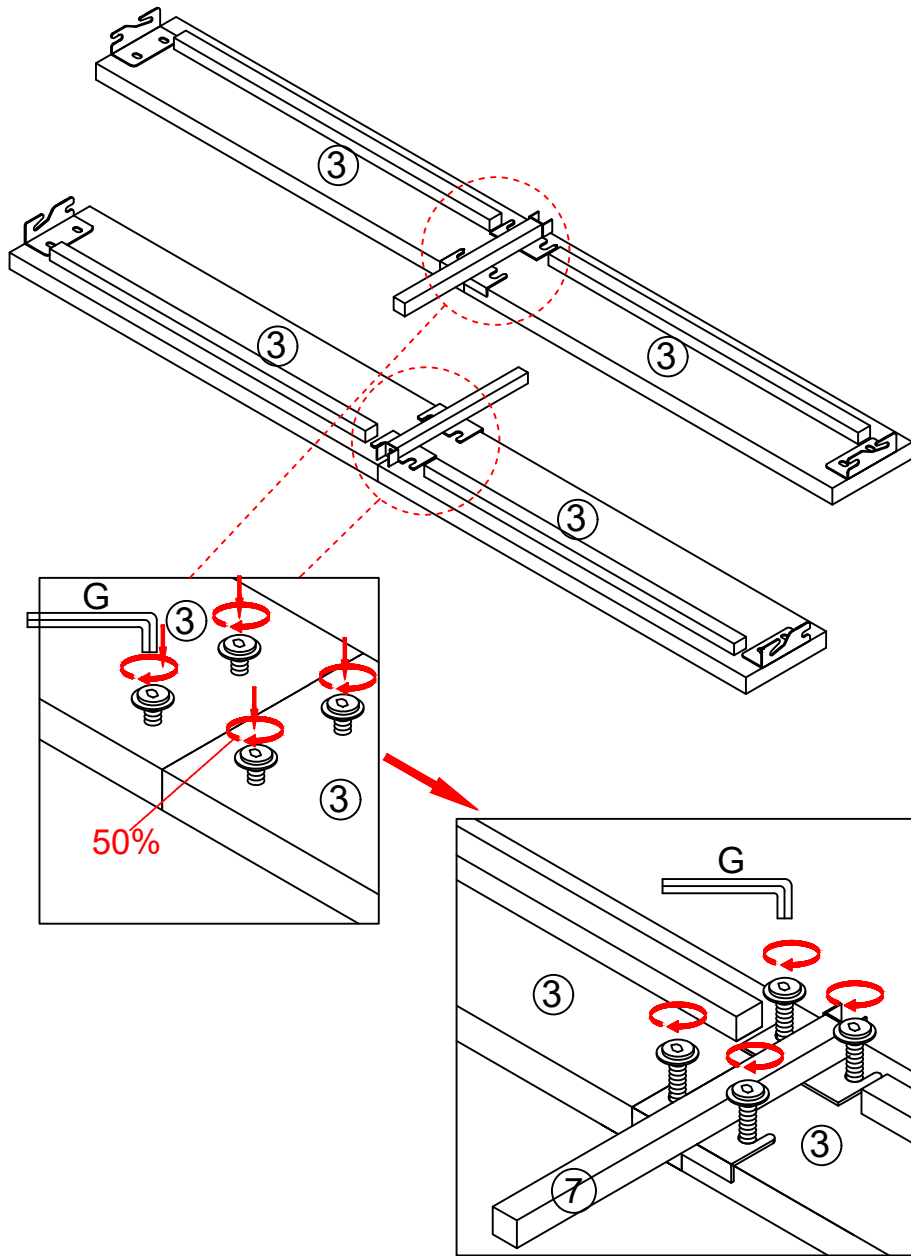

Step 4

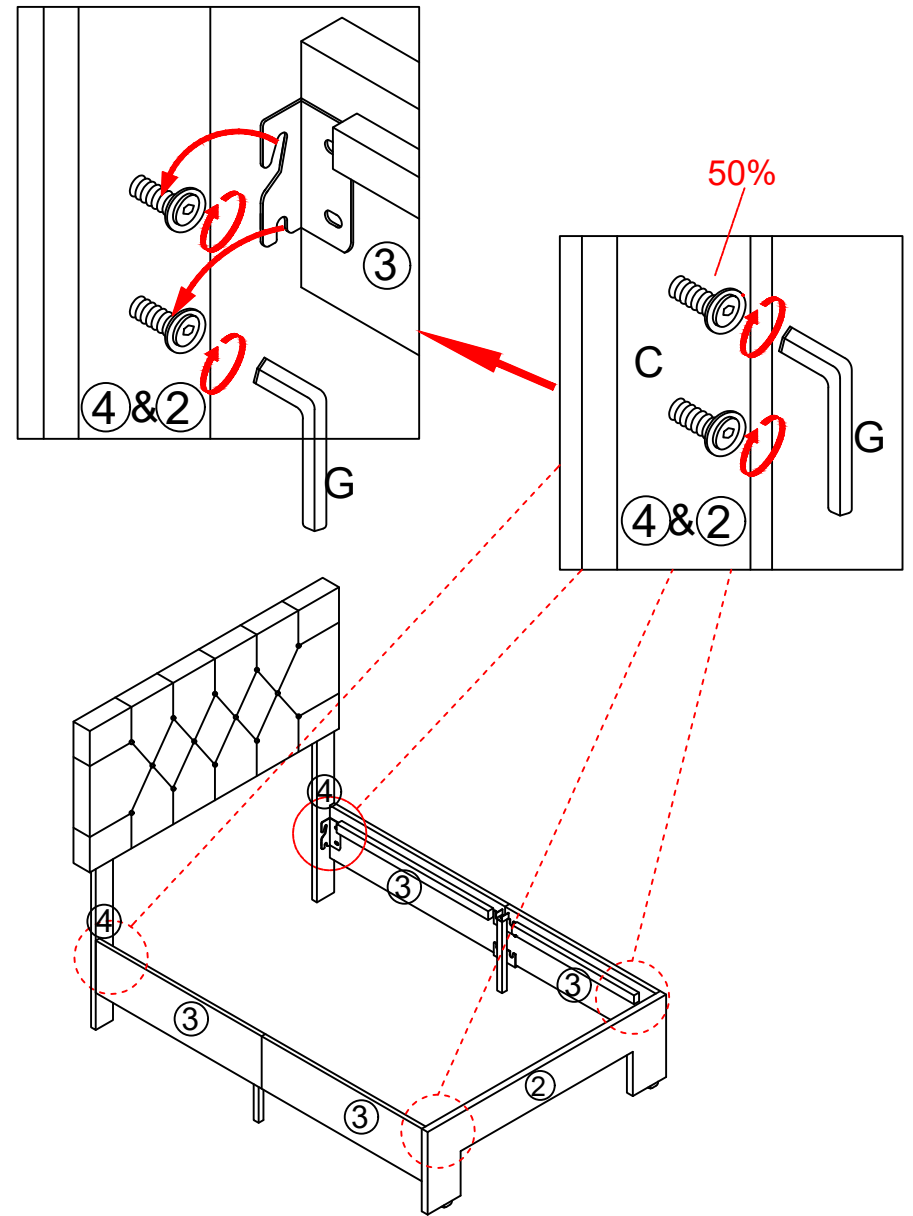

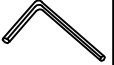

Step 5

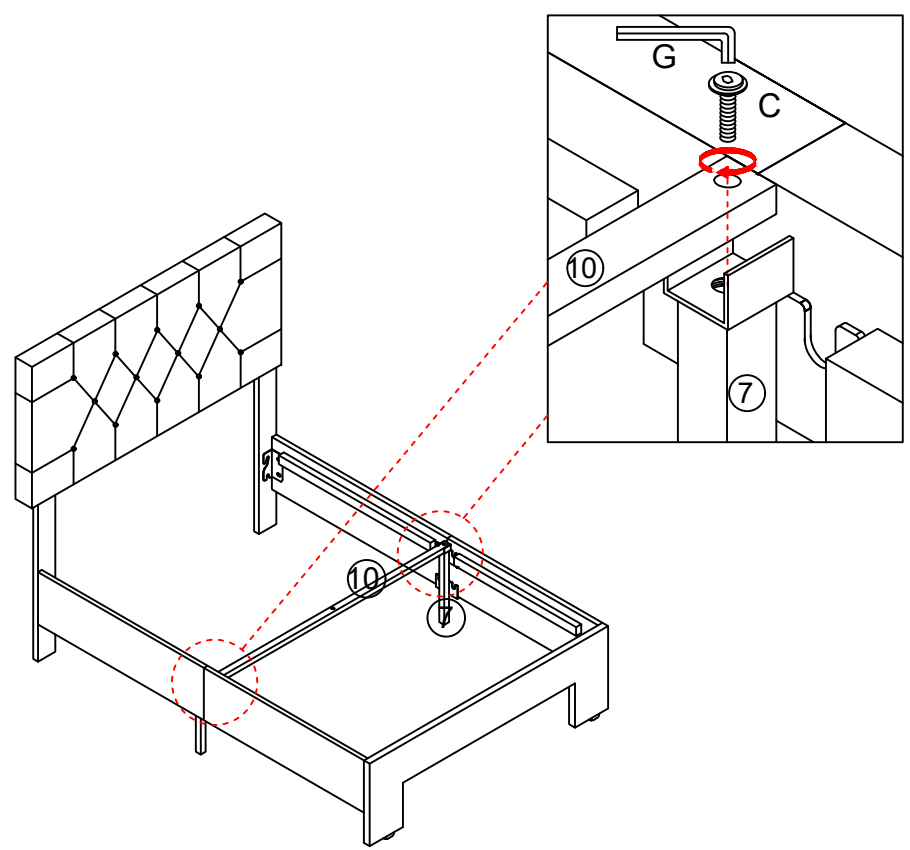
	C*2		G*1
--	-----	--	-----

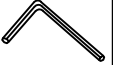

Step 6

	C*2		D*2		G*1
--	-----	--	-----	--	-----

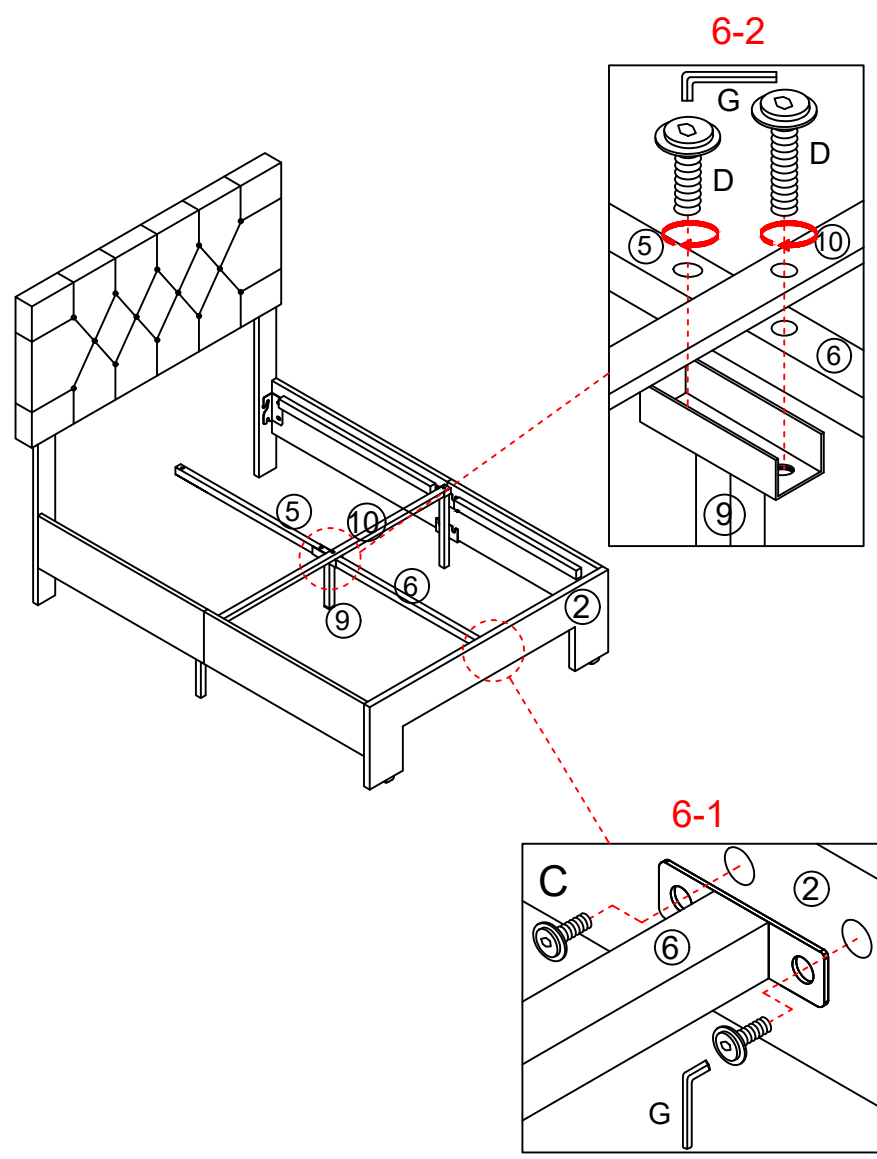

Tighten the original screw

Step 7

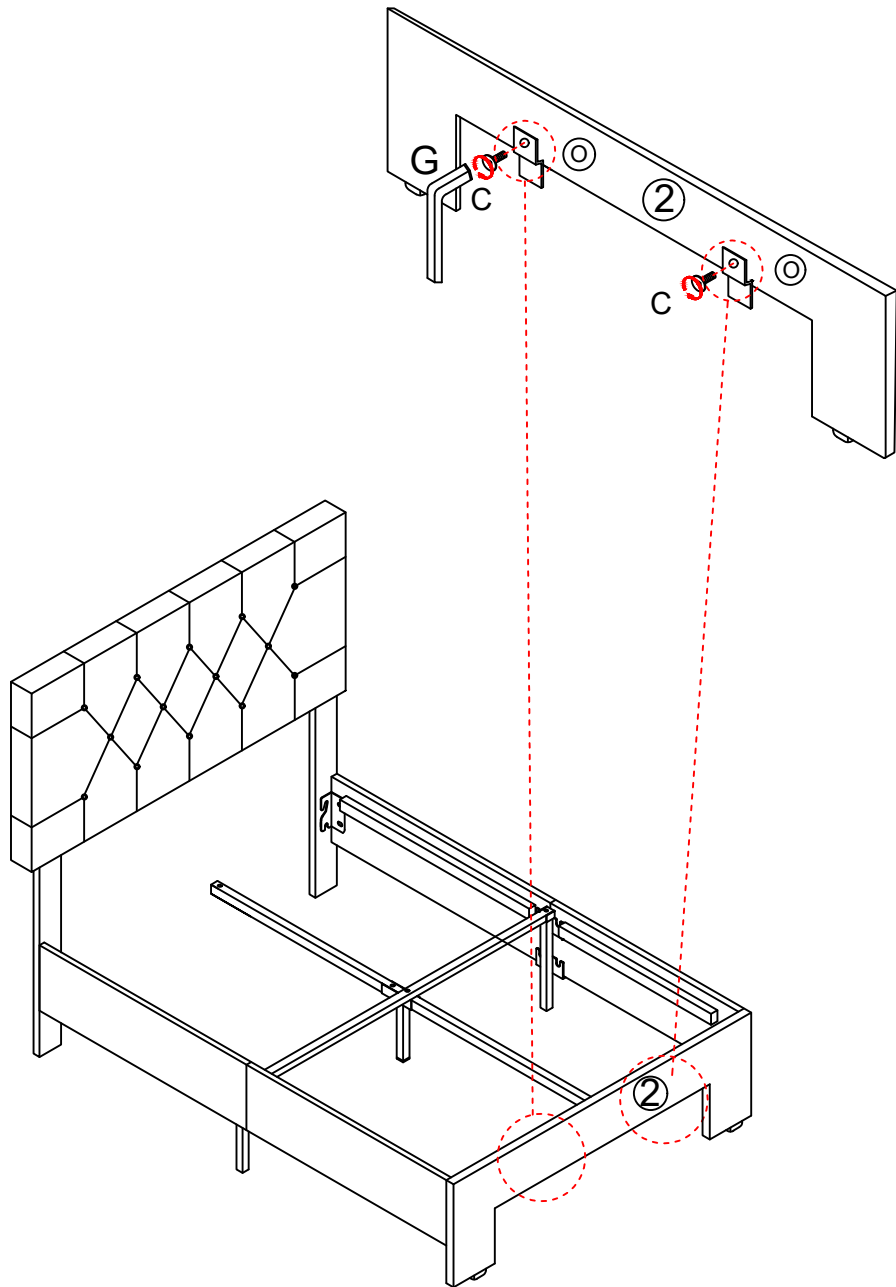
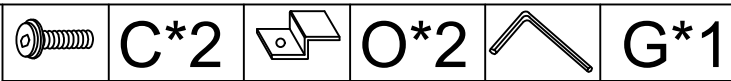

Step 8

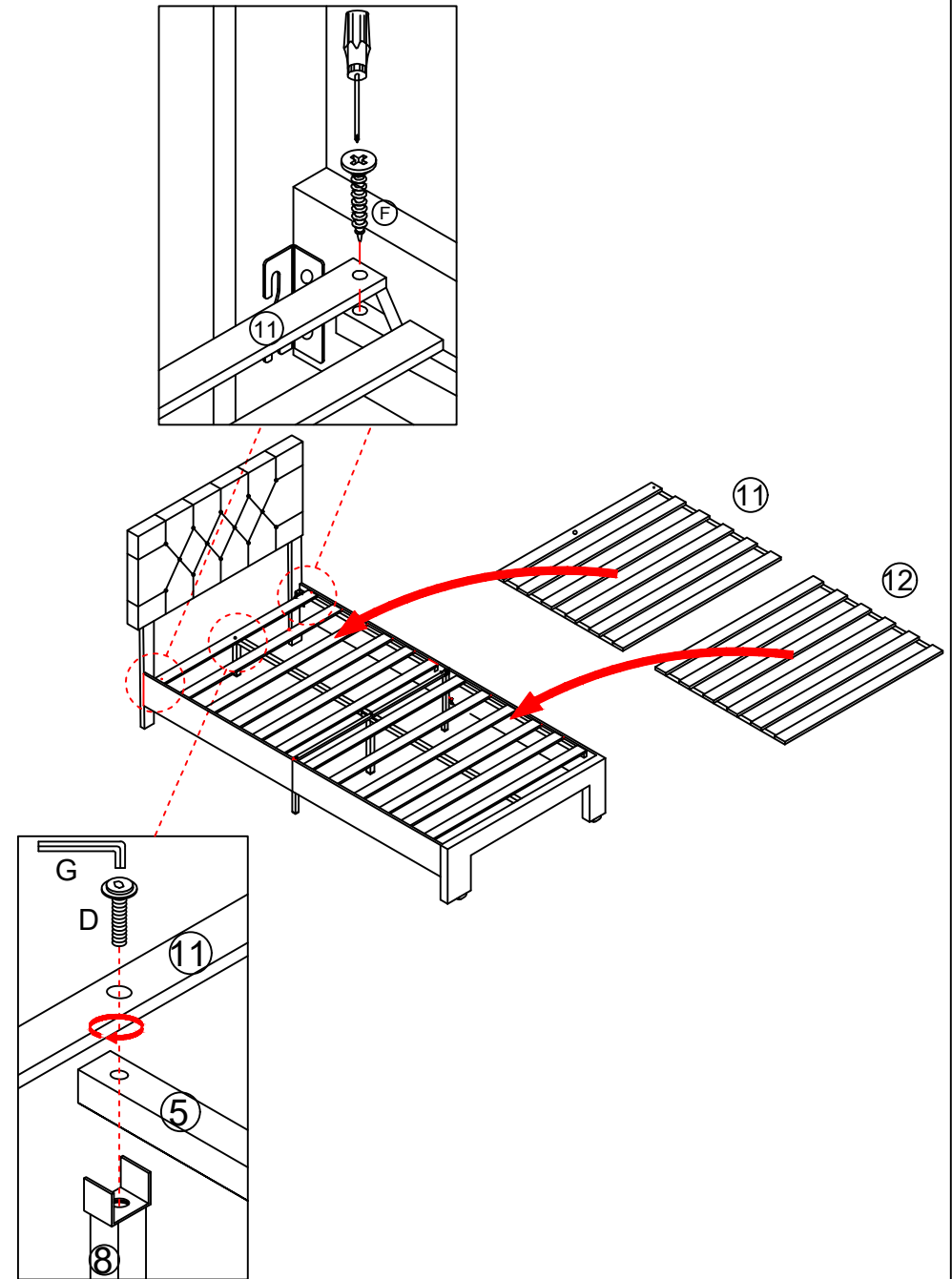
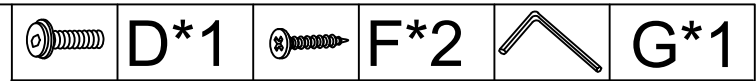

Step 9



L*2

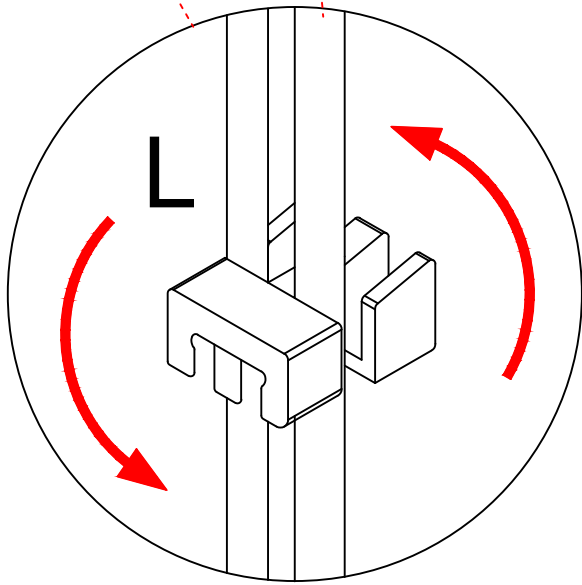
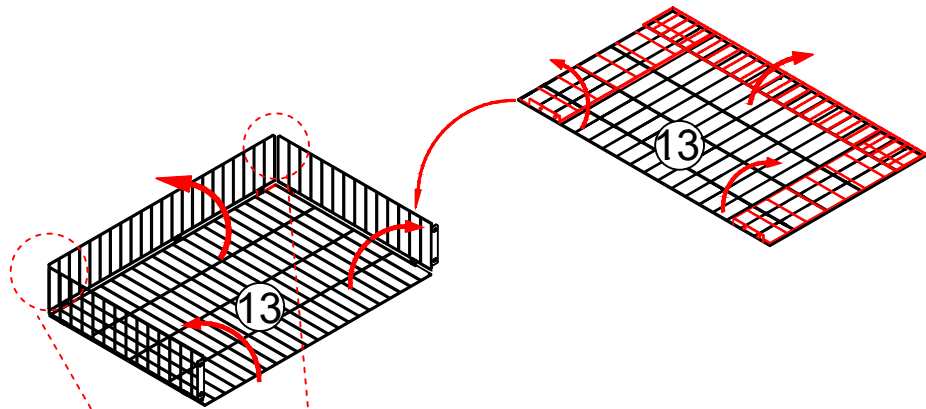

Step 10



A*5



K*1



H*1

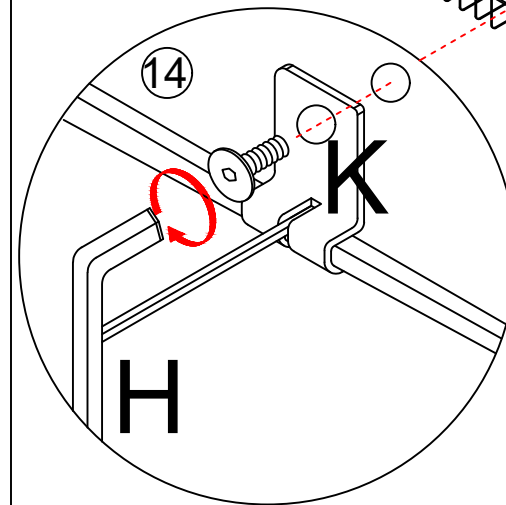
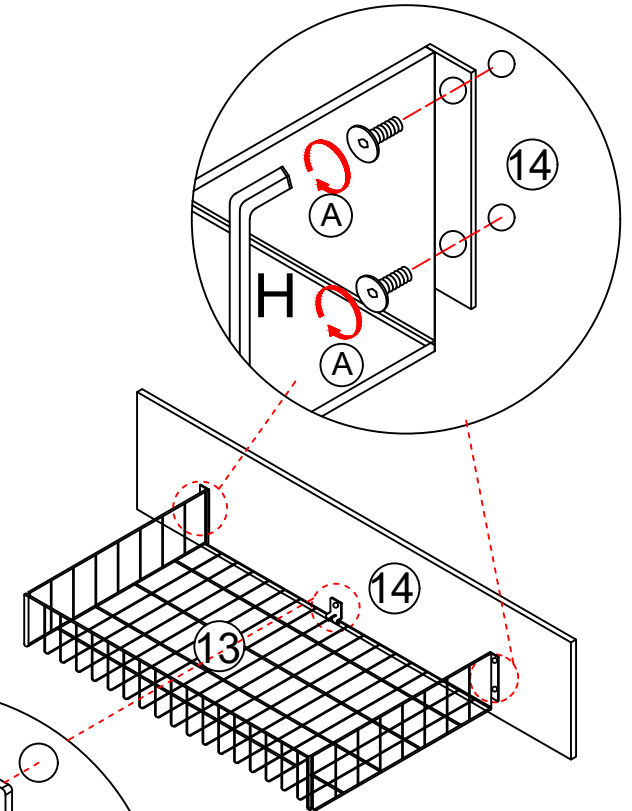

Step 11



M*5

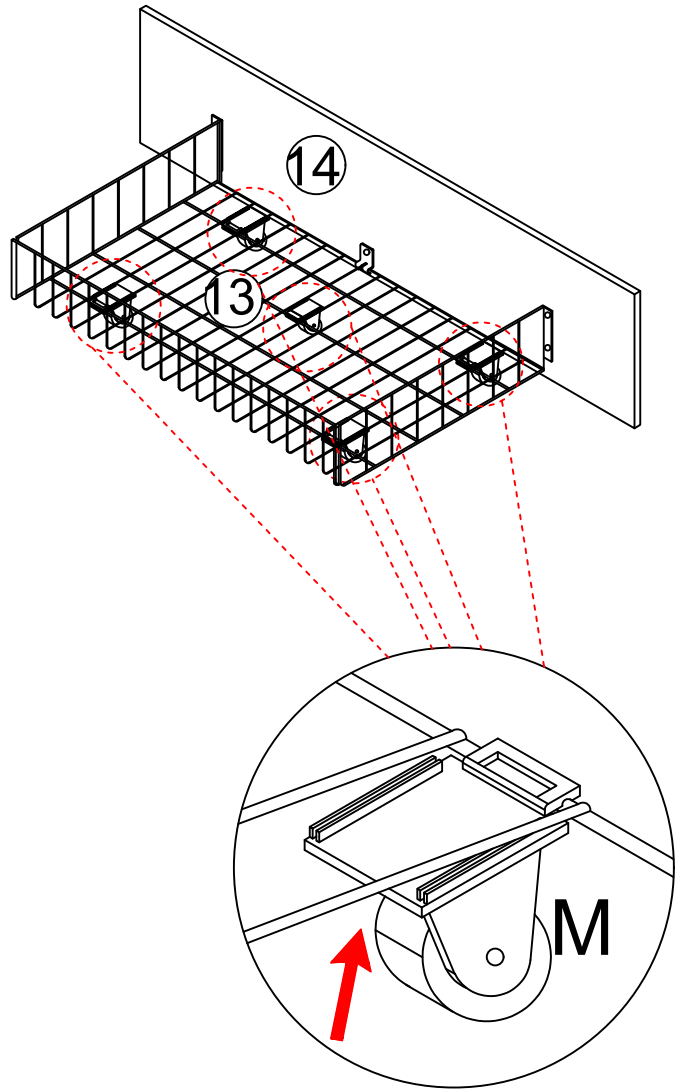

Step 12

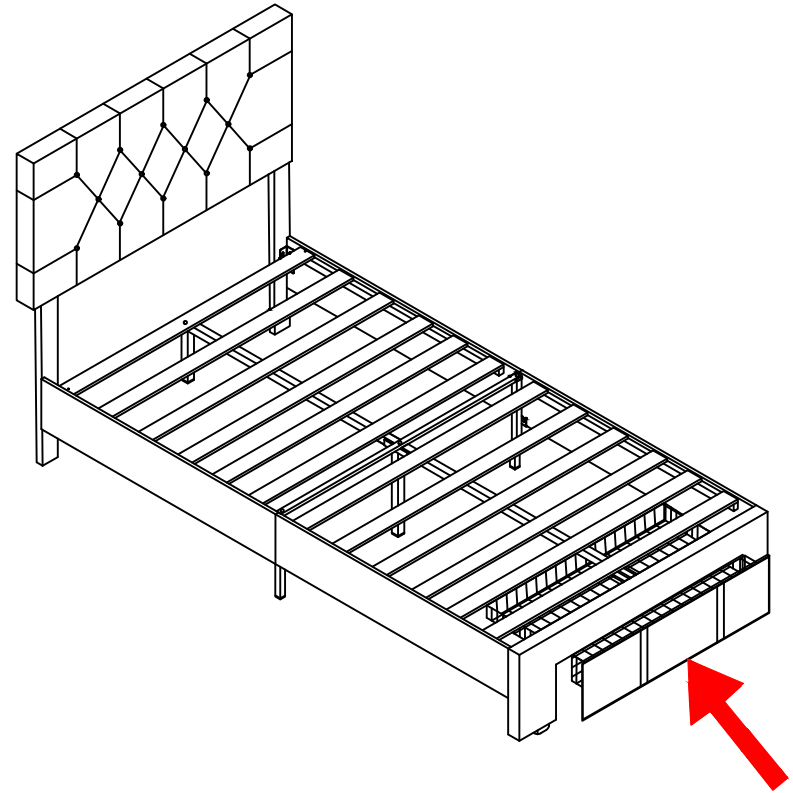

Step 13

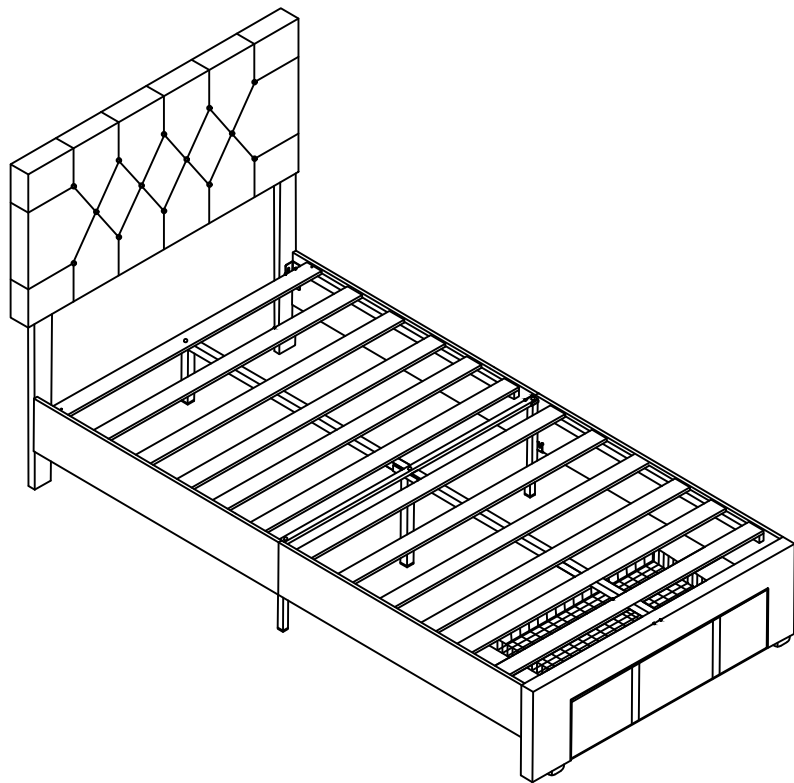

● Note: Now remember to double check all screws are properly fastened.

★ Hinweis: Vergessen Sie jetzt nicht, zu überprüfen, ob alle Schrauben richtig angezogen sind.

▲ Remarque : N'oubliez pas de vérifier que toutes les vis sont bien serrées.

■ Nota: Ora ricordati di ricontrollare che tutte le viti siano correttamente fissate.

✿ Nota: Ahora recuerde volver a verificar que todos los tornillos estén correctamente apretados.

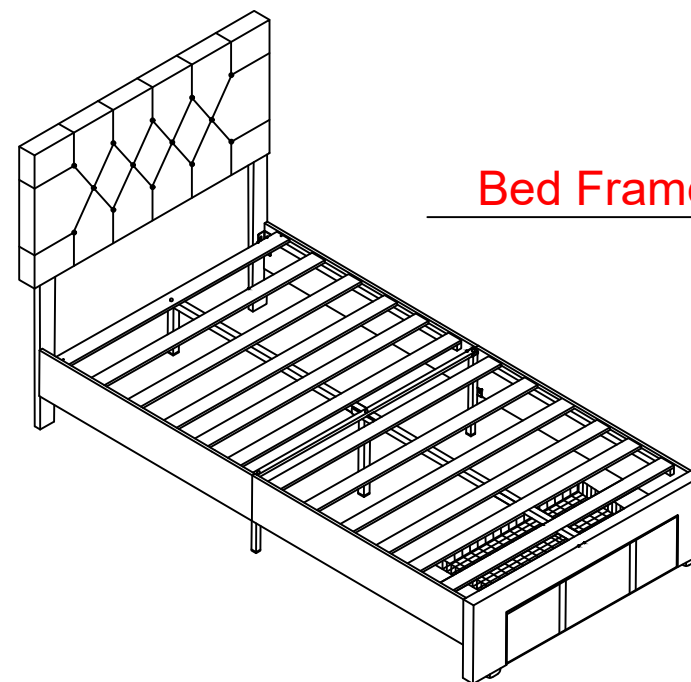

Bed Frame