

Montageanleitung | Instructions de montage Assembly Instructions | Instrucciones de montaje

SKU NUMBER:N652P338580/N652P338581

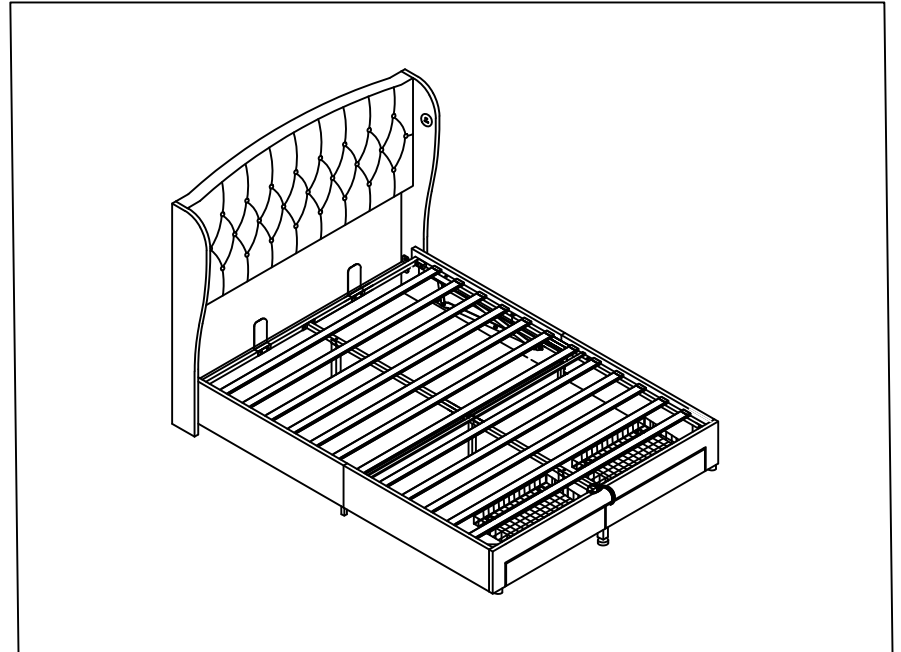

(GB) This set comes in 2 boxes. If you do not receive a full set of 2 boxes, please contact our customer service.

(DE) Dieses Set wird in 2 Schachteln geliefert. Wenn Sie nicht ein komplettes Set von 2 Boxen erhalten, kontaktieren Sie bitte unseren Kundenservice.

(FR) Ce set est livré en 2 boîtes. Si vous ne recevez pas un jeu complet de 2 boîtes, veuillez contacter notre service clientèle.



English IMPORTANT FOR GAS LIFT BEDS&MAINTAINCE

- Please place the mattress on top of the bed frame.
- Please do not pull on the strap handles.
- Please press heavily to release the compressed gas.
- Periodically check all screw & fixings to ensure they are secure.
- When moving your product, carefully lift into place.
- Wipe clean with a slightly damp cloth- please do not use abrasive chemicals or bleach.
- Do NOT allow children to operate the lift mechanism.
- Do NOT allow children near the lift base when operating the mechanism.
- Do NOT stand inside the bed or the internal storage base.
- Do NOT overload the internal storage base.
- DO NOT jump on the product or any of its parts.

Deutsch WICHTIG FÜR GASLIFT-BETTEN&WARTUNG

- Bitte legen Sie die Matratze oben auf den Bettrahmen.
- Bitte ziehen Sie nicht an den Gurtgriffen.
- Bitte drücken Sie kräftig, um das komprimierte Gas freizusetzen.
- Überprüfen Sie regelmäßig alle Schrauben und Befestigungen, um sicherzustellen, dass sie sicher sind.
- Wenn Sie Ihr Produkt bewegen, heben Sie es vorsichtig an seinen Platz.
- Mit einem leicht feuchten Tuch abwischen - bitte keine scheuernden Chemikalien oder Bleichmittel verwenden.
- Erlauben Sie Kindern NICHT, den Hebemechanismus zu bedienen.
- Lassen Sie Kinder NICHT in die Nähe des Liftsockels, wenn Sie den Mechanismus bedienen.
- Stellen Sie sich NICHT in das Bett oder in die Innenablage.
- Überlasten Sie den internen Liftsockel NICHT.
- Springen Sie NICHT auf das Produkt oder eines seiner Teile.

Français IMPORTANT POUR LES LITS À RELEVAGE DE GAZ&MAINTENANCE

- Veuillez placer le matelas sur le dessus du cadre de lit.
- Ne tirez pas sur les poignées de la sangle.
- Appuyez fortement pour libérer le gaz comprimé.
- Vérifiez régulièrement que toutes les vis et fixations sont bien en place.
- Lorsque vous déplacez votre produit, soulevez-le avec précaution pour le mettre en place.
- Nettoyez avec un chiffon légèrement humide - n'utilisez pas de produits chimiques abrasifs ou d'eau de Javel.
- Ne laissez pas les enfants utiliser le mécanisme de levage.
- Ne laissez pas les enfants s'approcher de la base de levage lorsqu'ils actionnent le mécanisme.
- Ne vous tenez PAS à l'intérieur du lit ou de la base de stockage interne.
- Ne surchargez pas la base de stockage interne.
- Ne pas sauter sur le produit ou l'une de ses parties.

ZERTIFIKAT ◆ CERTIFICATE ◆ 認 證 證 書 ◆ CERTIFICADO ◆ CERTIFICAT

UK
CA



Attestation of Conformity

No. E8AUK 103501 0144 Rev. 00

Tested
according to:

EN IEC 55014-1:2021
EN IEC 55014-2:2021
EN 55032:2015/A11:2020
EN 55035:2017/A11:2020
EN IEC 61000-3-2:2019/A1:2021
EN 61000-3-3:2013/A2:2021
BS EN IEC 55014-1:2021
BS EN IEC 55014-2:2021
BS EN 55032:2015/A11:2020
BS EN 55035:2017/A11:2020
BS EN IEC 61000-3-2:2019/A1:2021
BS EN 61000-3-3:2013/A2:2021

Page 4 of 4

After preparation of the necessary UK regulation technical documentation as well as the UK declaration of conformity the required UKCA marking can be affixed on the product. Other applicable UK regulations have to be observed.

TÜV SÜD Certification and Testing (China) Co., Ltd. No. 10, Huaxia Rd.(m), Xishan District, Wuxi, Jiangsu, P. R. China

TUV[®]

Attestation of Conformity

No. E8AUK 103501 0144 Rev. 00

Model	Rated output voltage (VDC)	Rated output current (A)	Max. rated output power (W)
J121-xxxxxxxX, J061-xxxxxxxX, J121L-xxxxxxxX, J061L-xxxxxxxX, J121L-xxxxxxxIX, J061L-xxxxxxxIX	4.5-8.9	0.001-2.1	10.5
	9.0-16.0	0.001-1.33	12.0
	16.1-30.0	0.001-0.745	12.0
J121-050yyyyyU, J061-050yyyyyU, J121L-050yyyyyU, J061L-050yyyyyU, J121L-050yyyyyIU, J061L-050yyyyyIU	5.0	0.001-2.1	10.5



Model	Rated output voltage (VDC)	Rated output current (A)	Max. rated output power (W)
J150-xxxxxxxX, J012-xxxxxxxX, J180-xxxxxxxX, J151-xxxxxxxX, J180-xxxxxxxIX, J151-xxxxxxxIX, J180A-xxxxxxxX, J151A-xxxxxxxX, J180A-xxxxxxxIX, J151A-xxxxxxxIX, J180C-xxxxxxxX	4.5-8.9	0.01-3.0	15.0
	9.0-16.0	0.01-2.0	18.0
	16.1-30.0	0.01-1.12	18.0
J150-050yyyyyU, J012-050yyyyyU, J180-050yyyyyU, J151-050yyyyyU, J180-050yyyyyIU, J151-050yyyyyIU, J180A-050yyyyyU, J151A-050yyyyyU, J180A-050yyyyyIU, J151A-050yyyyyIU	5.0	0.01-3.0	15.0

Page 3 of 4

After preparation of the necessary UK regulation technical documentation as well as the UK declaration of conformity the required UKCA marking can be affixed on the product. Other applicable UK regulations have to be observed.

Italiano

IMPORTANTE PER I LETTI CON SOLLEVAMENTO A GAS E LA MANUTENZIONE

- Posizionare il materasso sopra la struttura del letto.
- Non tirare le maniglie della cinghia.
- Premere con forza per rilasciare il gas compresso.
- Controllare periodicamente tutte le viti e i fissaggi per assicurarsi che siano saldi.
- Quando si sposta il prodotto, sollevarlo con cautela.
- Pulire con un panno leggermente umido, senza usare prodotti chimici abrasivi o candeggina.
- NON permettere ai bambini di azionare il meccanismo di sollevamento.
- NON permettere ai bambini di avvicinarsi alla base di sollevamento quando si aziona il meccanismo.
- NON sostare all'interno del letto o della base di contenimento interna.
- NON sovraccaricare la base di contenimento interna.
- NON saltare sul prodotto o sulle sue parti.

Español

IMPORTANTE PARA LAS CAMAS ELEVADORAS DE GAS&MANTENIMIENTO

- Coloque el colchón sobre el somier.
- No tire de las asas de la correa.
- Presione con fuerza para liberar el gas comprimido.
- Compruebe periódicamente que todos los tornillos y fijaciones estén bien sujetos.
- Al mover el producto, levántelo con cuidado para colocarlo en su sitio.
- Limpie con un paño ligeramente humedecido; no utilice productos químicos abrasivos ni lejía.
- NO permita que los niños accionen el mecanismo de elevación.
- NO permita que los niños se acerquen a la base elevadora cuando accionen el mecanismo.
- NO se ponga de pie dentro de la cama o de la base de almacenamiento interna.
- NO sobrecargue el somier.
- NO salte sobre el producto ni sobre ninguna de sus piezas.

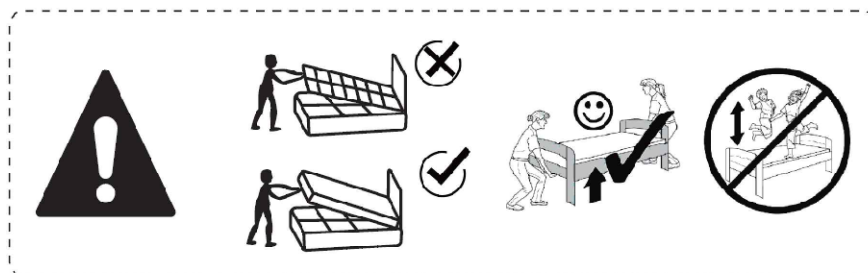

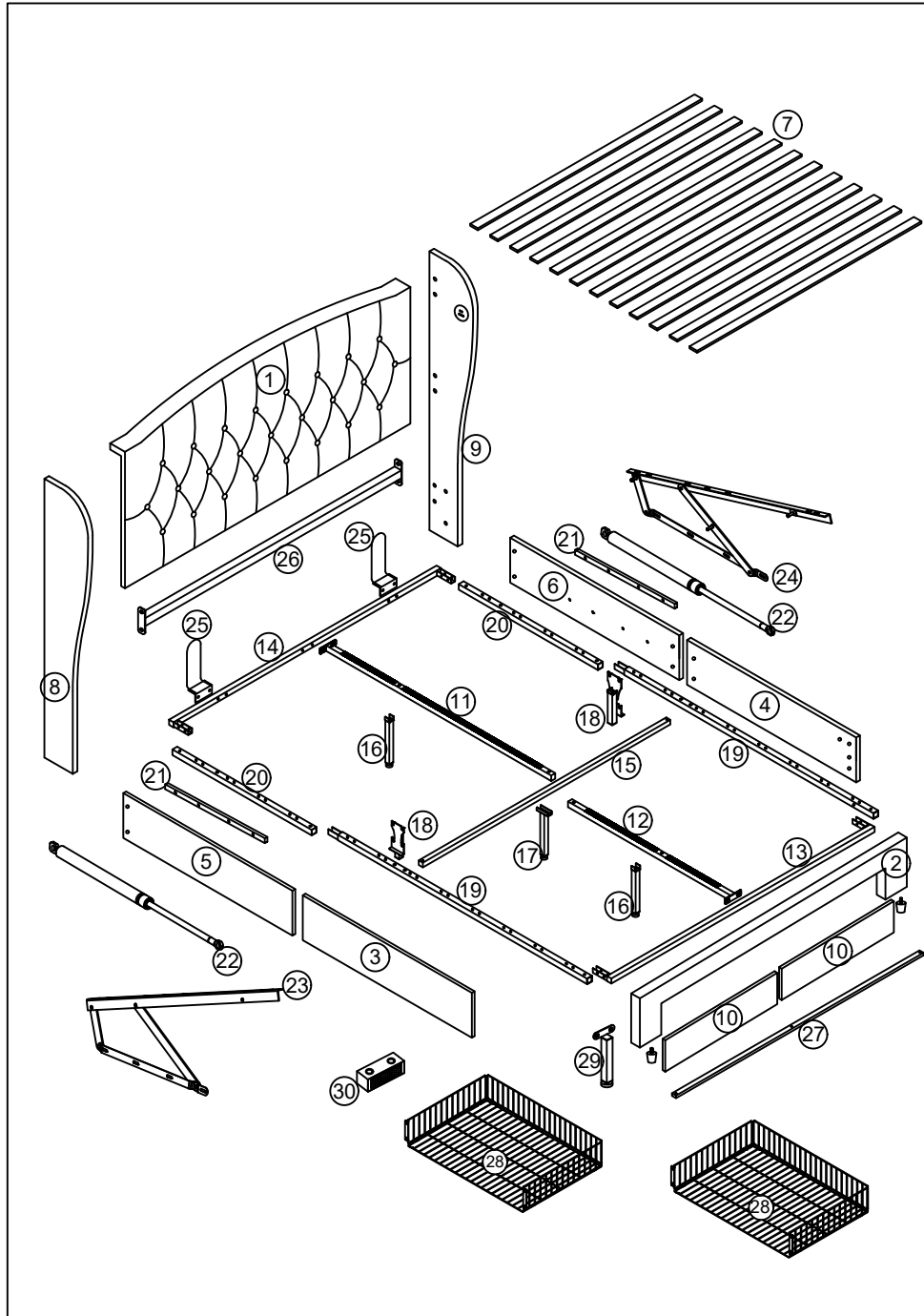

Attestation of Conformity

No. E8AUK 103501 0144 Rev. 00

Model(s):

J121-xxxxxxxwX, J061-xxxxxxxwX,
 J121-050yyyywU, J061-050yyyywU,
 J121L-xxxxxxxIX, J061L-xxxxxxxIX,
 J121L-050yyyyIU, J061L-050yyyyIU,
 J121L-xxxxxxxEX, J061L-xxxxxxxEX,
 J121L-050yyyyEU, J061L-050yyyyEU
 (xxx=045-300, stand for rated output voltage from 4.5VDC to 30.0VDC; yyyy=0001-2100, stand for rated output current from 0.001A to 2.1A; w=E, B or S, represent for different mains plug, E means European plug; B means British plug, S means Australia plug.)
 J150-xxxxxxxEX, J150-050yyyyEU,
 J012-xxxxxxxEX, J012-050yyyyEU,
 J180-xxxxxxxwX, J151-xxxxxxxwX,
 J180-050yyyywU, J151-050yyyywU,
 J180-xxxxxxxIX, J151-xxxxxxxIX,
 J180-050yyyyIU, J151-050yyyyIU,
 J180A-xxxxxxxwX, J151A-xxxxxxxwX,
 J180A-050yyyywU, J151A-050yyyywU,
 J180A-xxxxxxxIX, J151A-xxxxxxxIX,
 J180A-050yyyyIU, J151A-050yyyyIU,
 J180C-xxxxxxxwX
 (xxx=045-300, stand for rated output voltage from 4.5VDC to 30.0VDC; yyyy=0010-3000, stand for rated output current from 0.01A to 3.0A; w=E, B or S, represent for different mains plug, E means European plug; B means British plug, S means Australia plug.)

Description of

Object:

Rated Input: 100-240VAC, 50/60Hz, 0.6A
 Rated Output: See below table for details
 Protection Class: II

Page 2 of 4

After preparation of the necessary UK regulation technical documentation as well as the UK declaration of conformity the required UKCA marking can be affixed on the product. Other applicable UK regulations have to be observed.

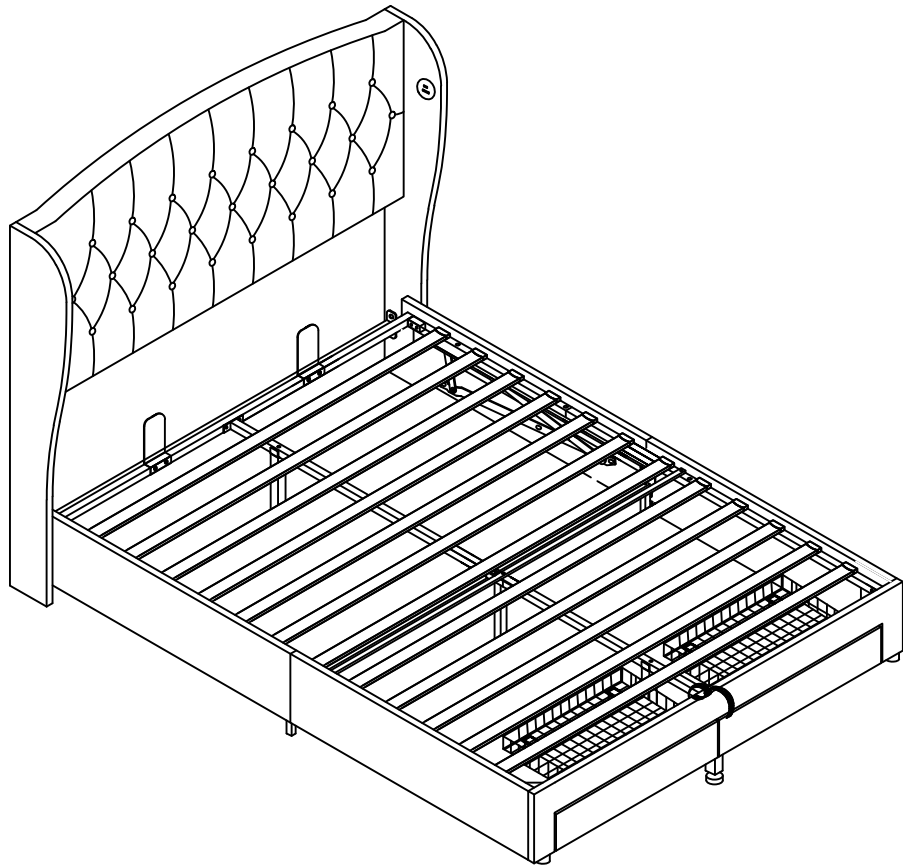

NA652P338580

①		1PC	②		1PC
⑩		2PCS	⑪		1PC
⑫		1PC	⑬		1PC
⑭		1PC	⑮		1PC
⑳		2PCS	㉒		2PCS
㉓		1PC	㉔		1PC
㉖		1PC	㉗		1PC
㉘		2PCS			

NA652P338581

③		1PC	④		1PC
⑤		1PC	⑥		1PC
⑦		12PCS	⑧		1PC
⑨		1PC	⑩		2PCS
⑪		1PC	⑫		2PCS
⑬		2PCS	⑭		2PCS
⑮		2PCS	⑯		1PC

20

Q X1

W X1



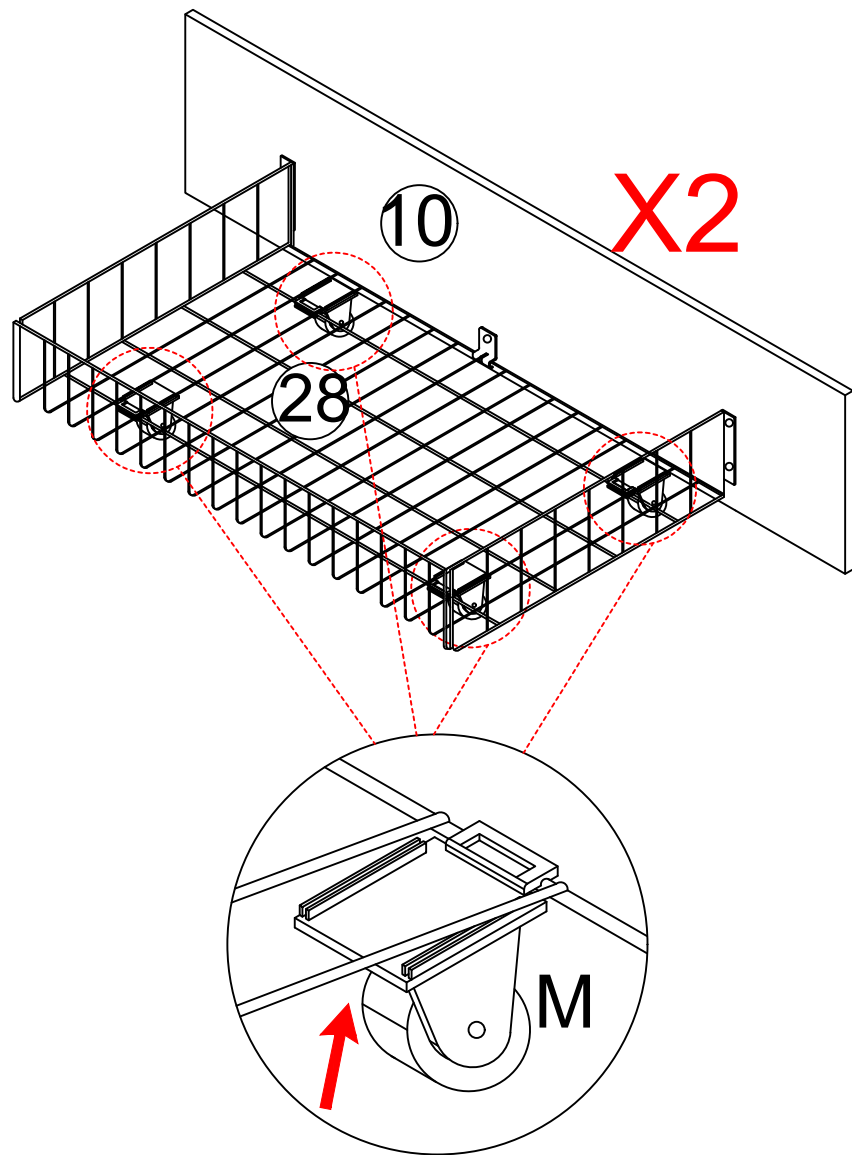





19

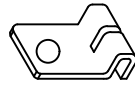

NA652P338581

A	M8 x 18	24	B	M8 x 25	34
C	M8 x 35	19	D	M8 x 40	9
E	M8 x 45	4	F	M5	1
I		4	J		1
U		18	V	M6 x 15	10
X	M4	1	Y	M8 x 55	2

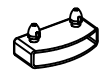
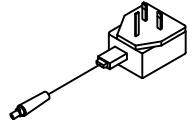
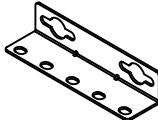
NA652P338581

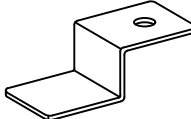
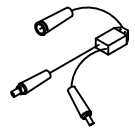
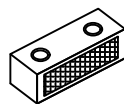
ⓐ		2	ⓓ		2
Ⓚ		2	Ⓛ		4
Ⓜ		8	Ⓝ		2
ⓐ		2	Ⓟ		24
Ⓠ		1	Ⓡ		2
Ⓢ		1	Ⓣ		2
Ⓦ		1	Ⓣⓐ		1PC

18

M6 x 15  X 10

 X 2

M4  X 1

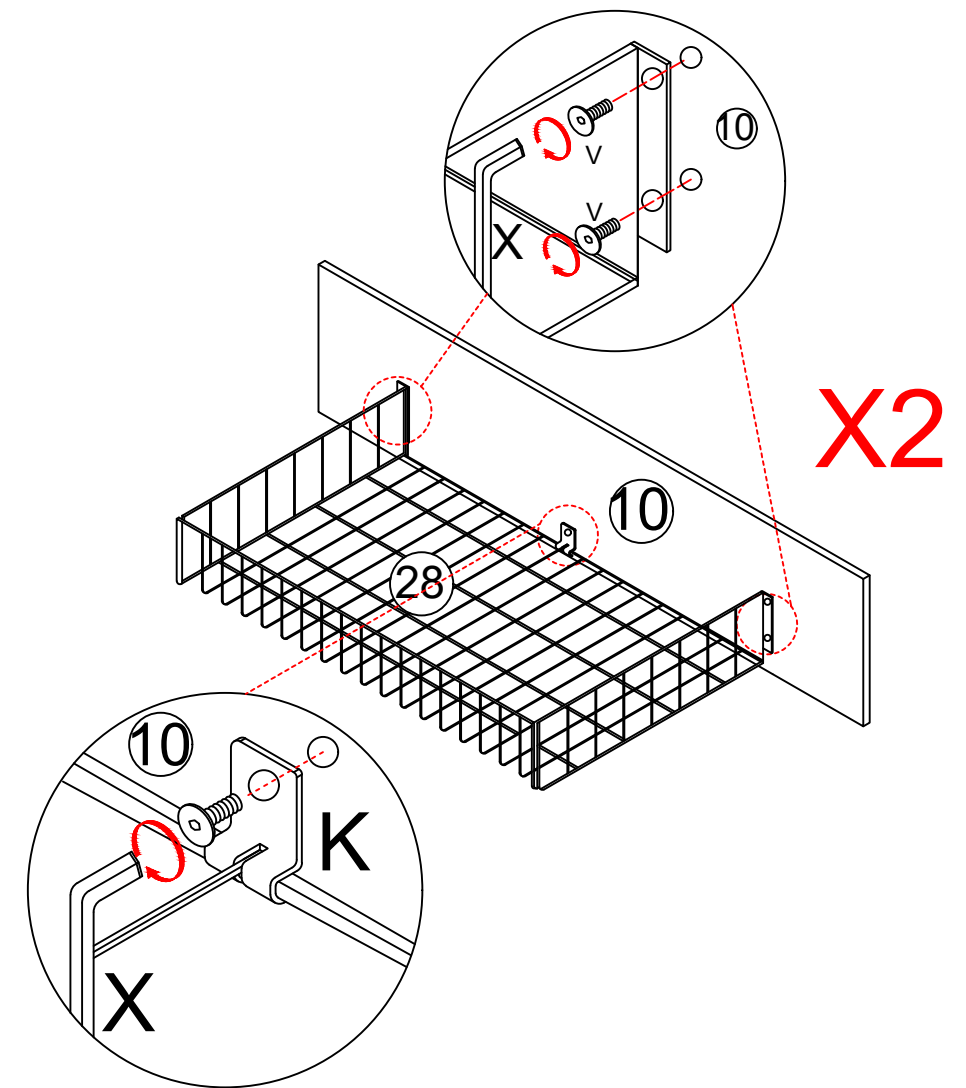

17



L X 4

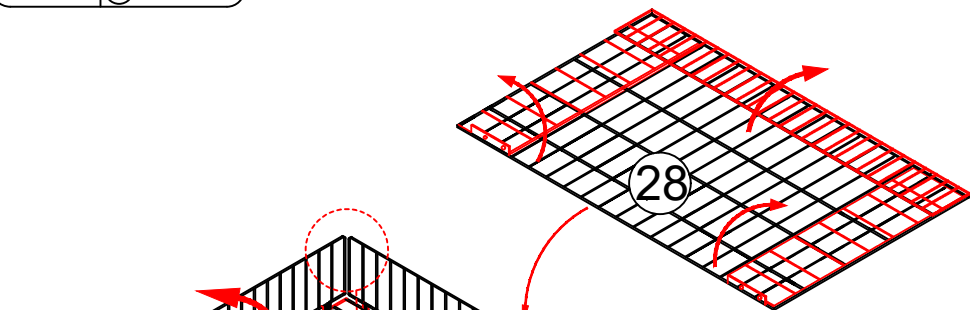

X2

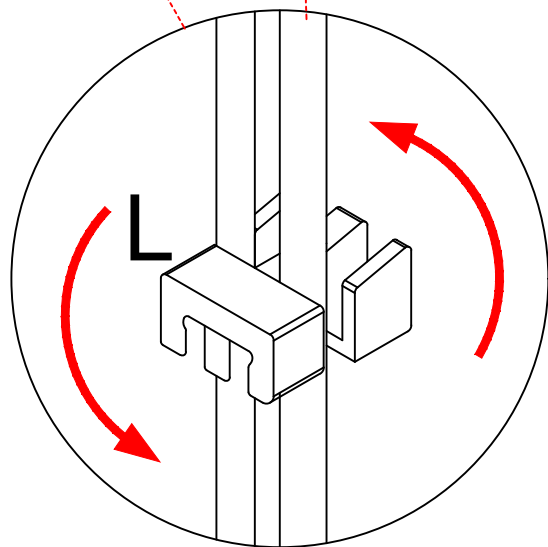

1

M8 x 18



A X 8

M8 x 25



B X 8



G X 2



H X 2

M5



F X 1

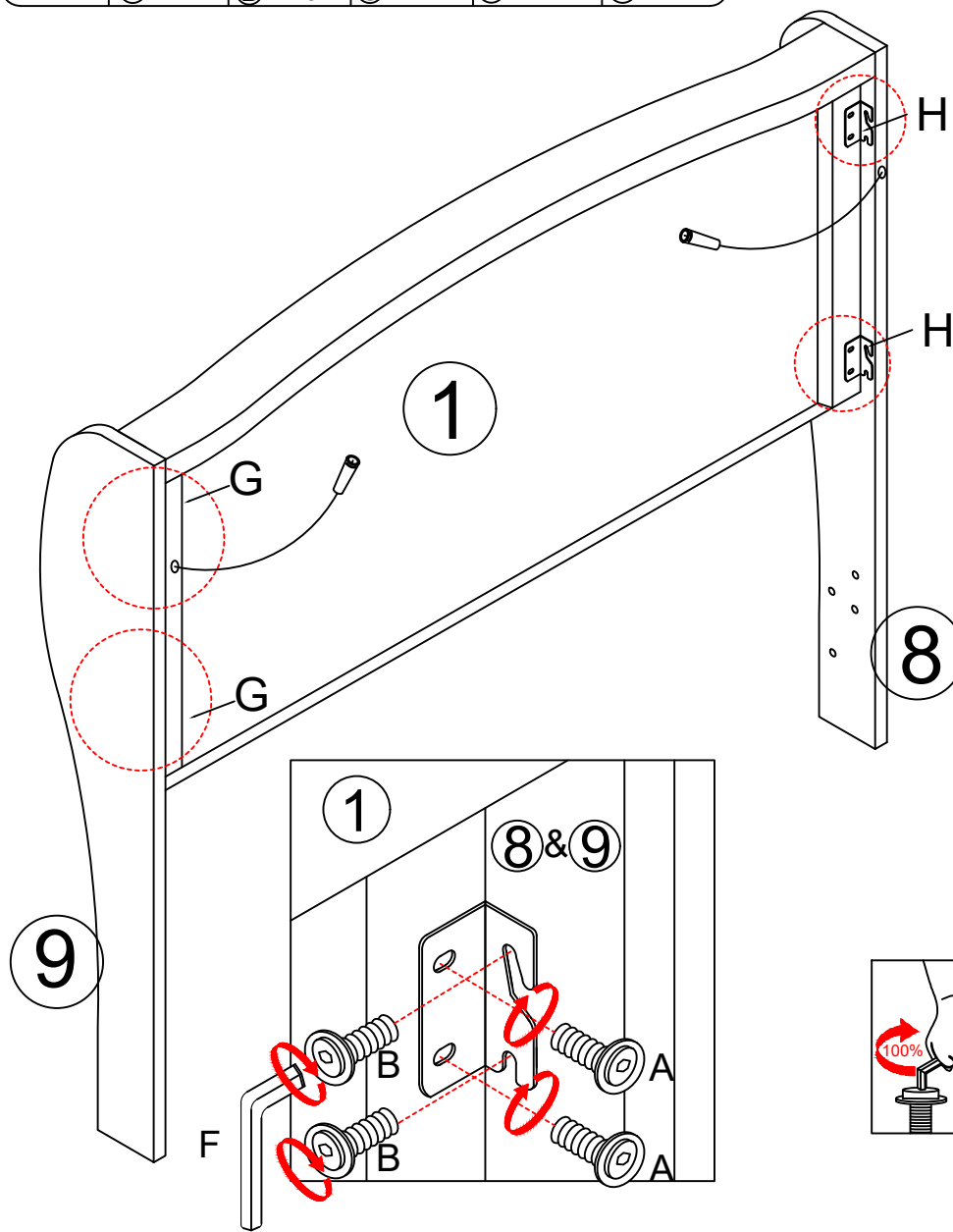

1

8

9

1

8 & 9

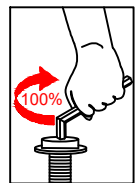

2

M8 x 25

M5

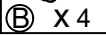

X 4

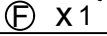

X 1

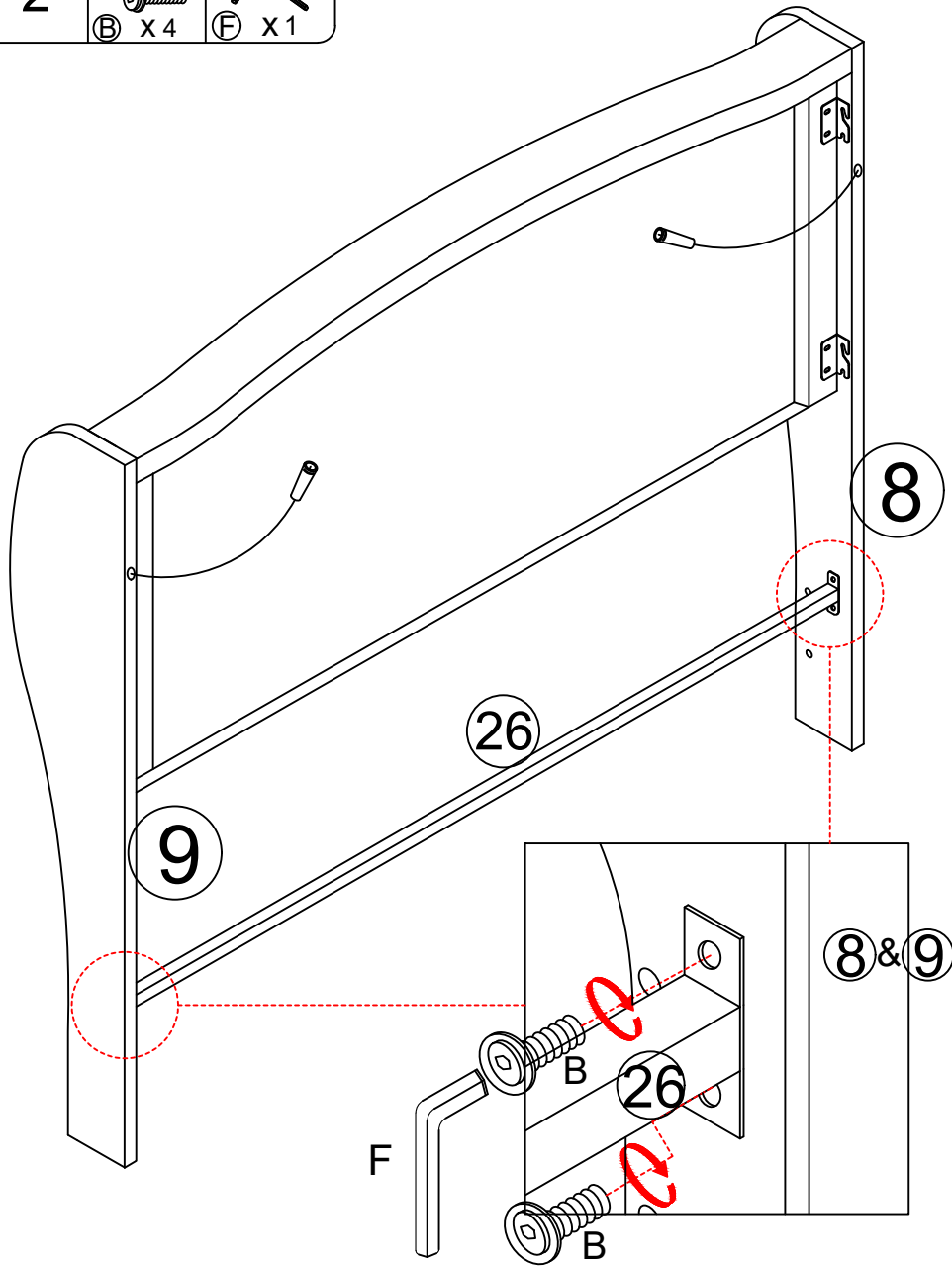





16

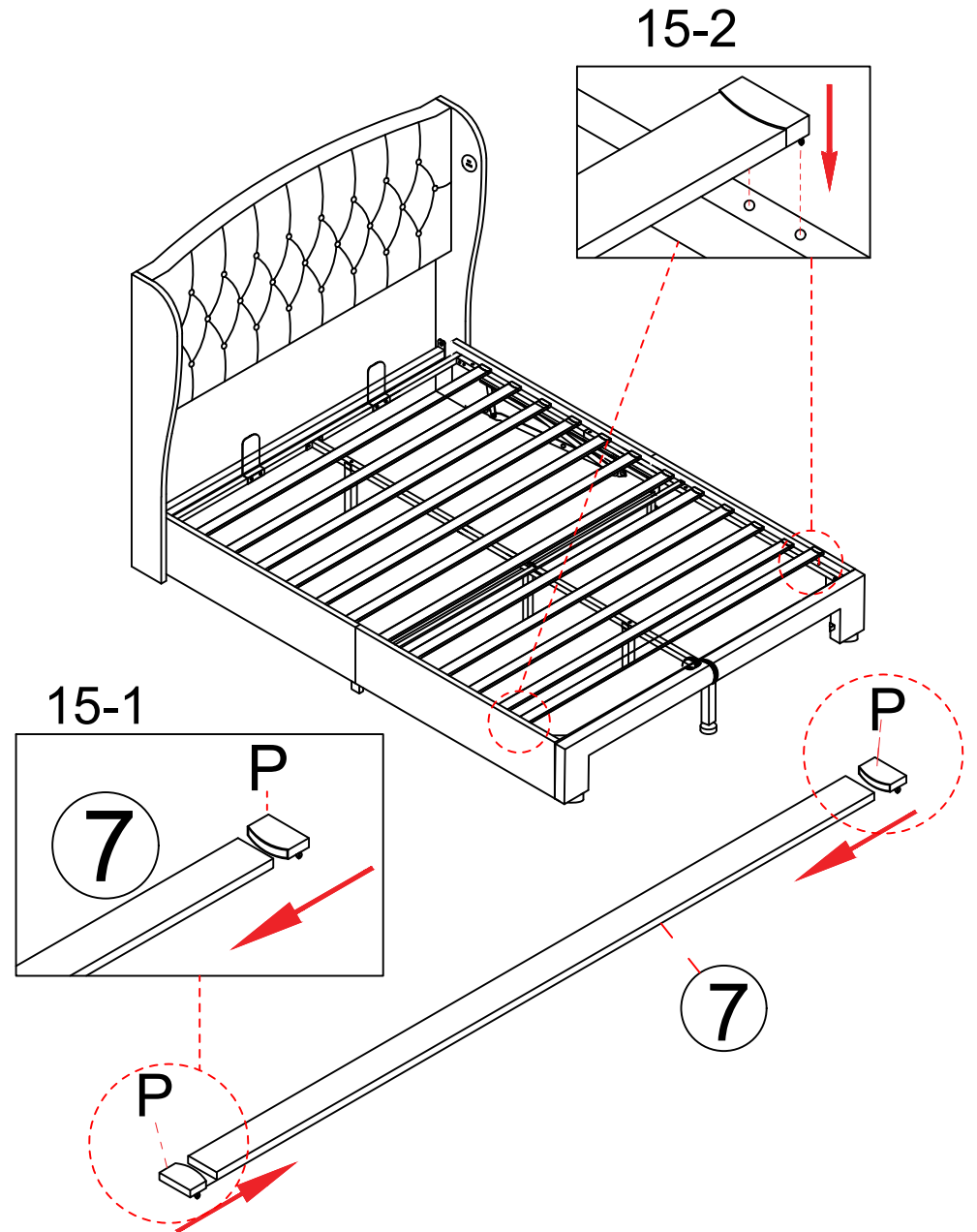

X 24



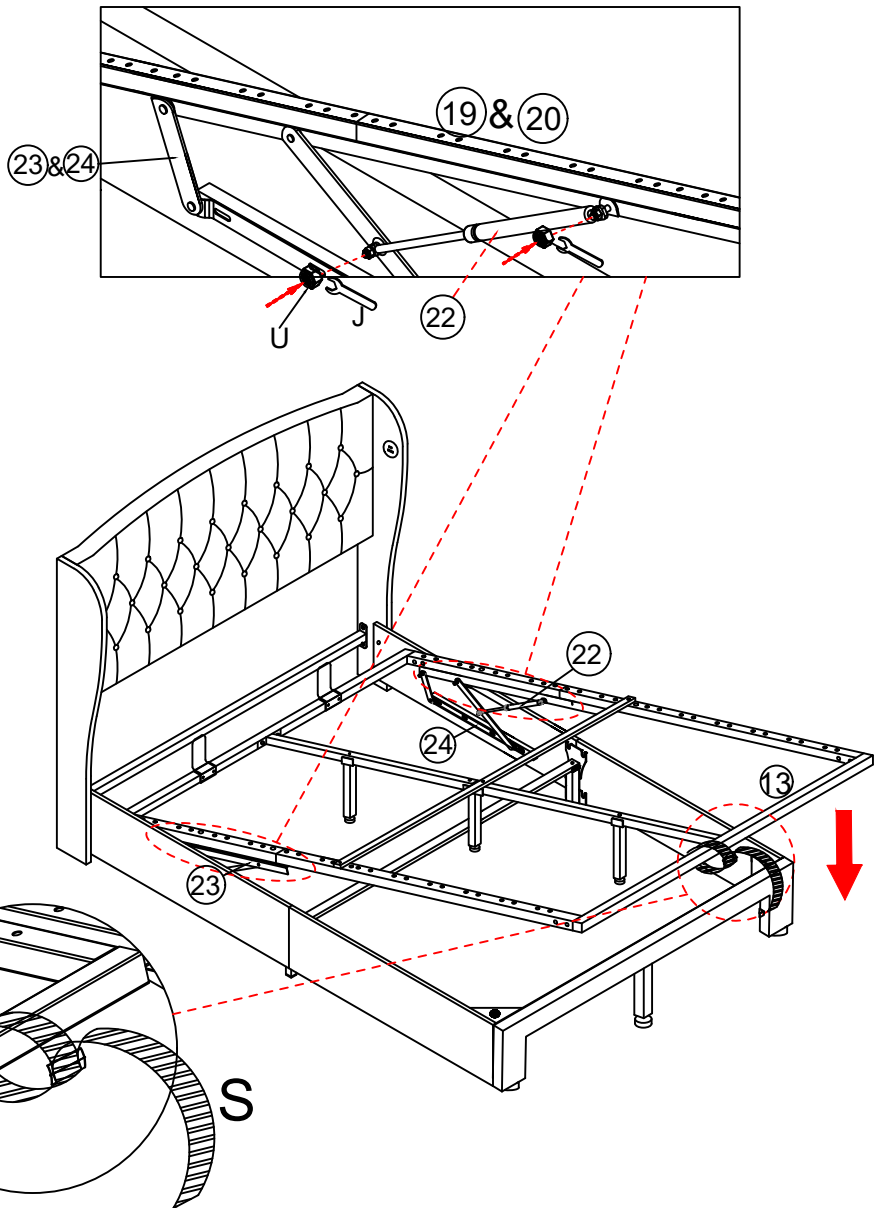

15

-  U x4
-  S x1
-  J x1
-  F x1



3

-  B x12
-  R x2
-  F x1

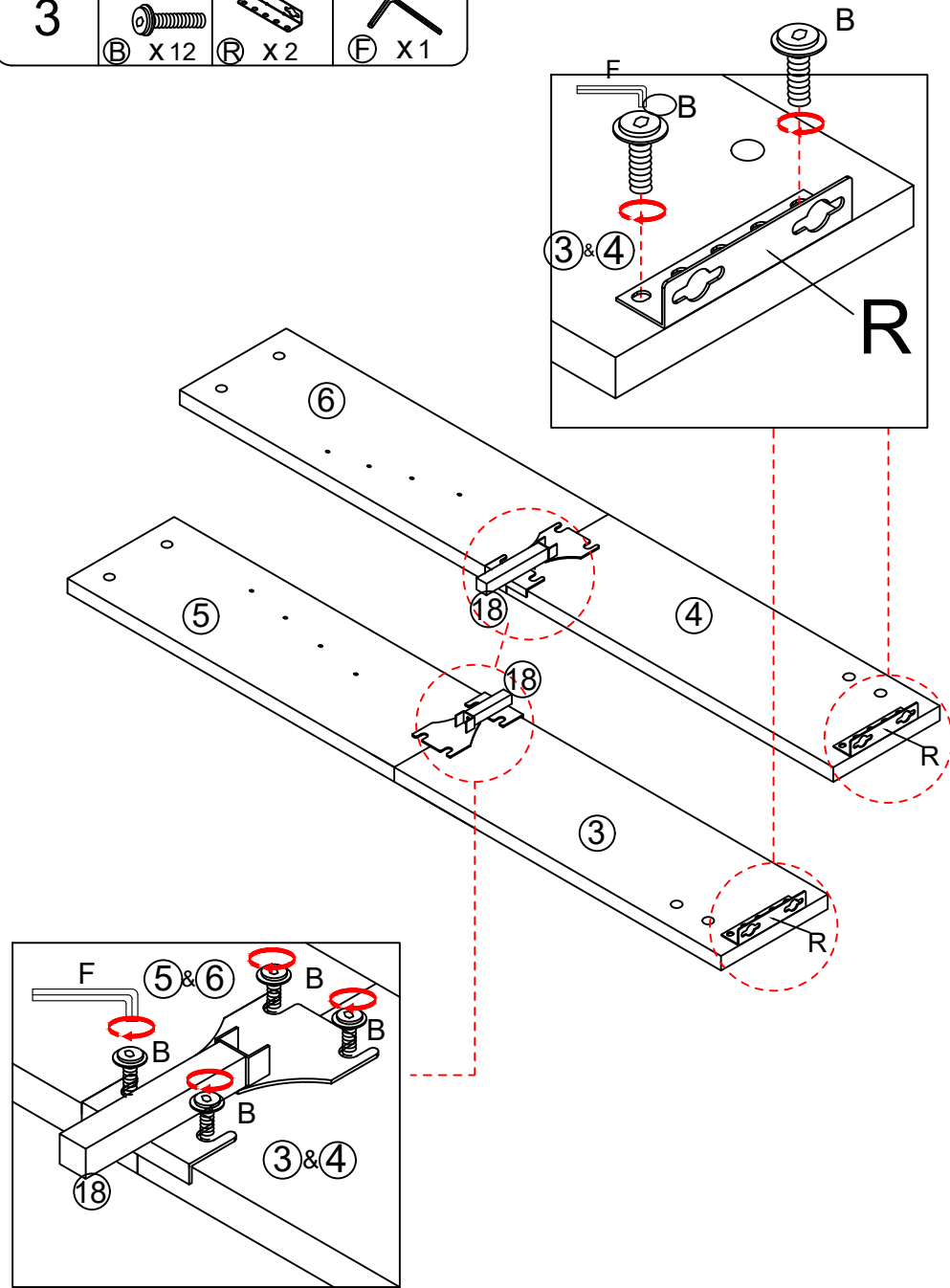

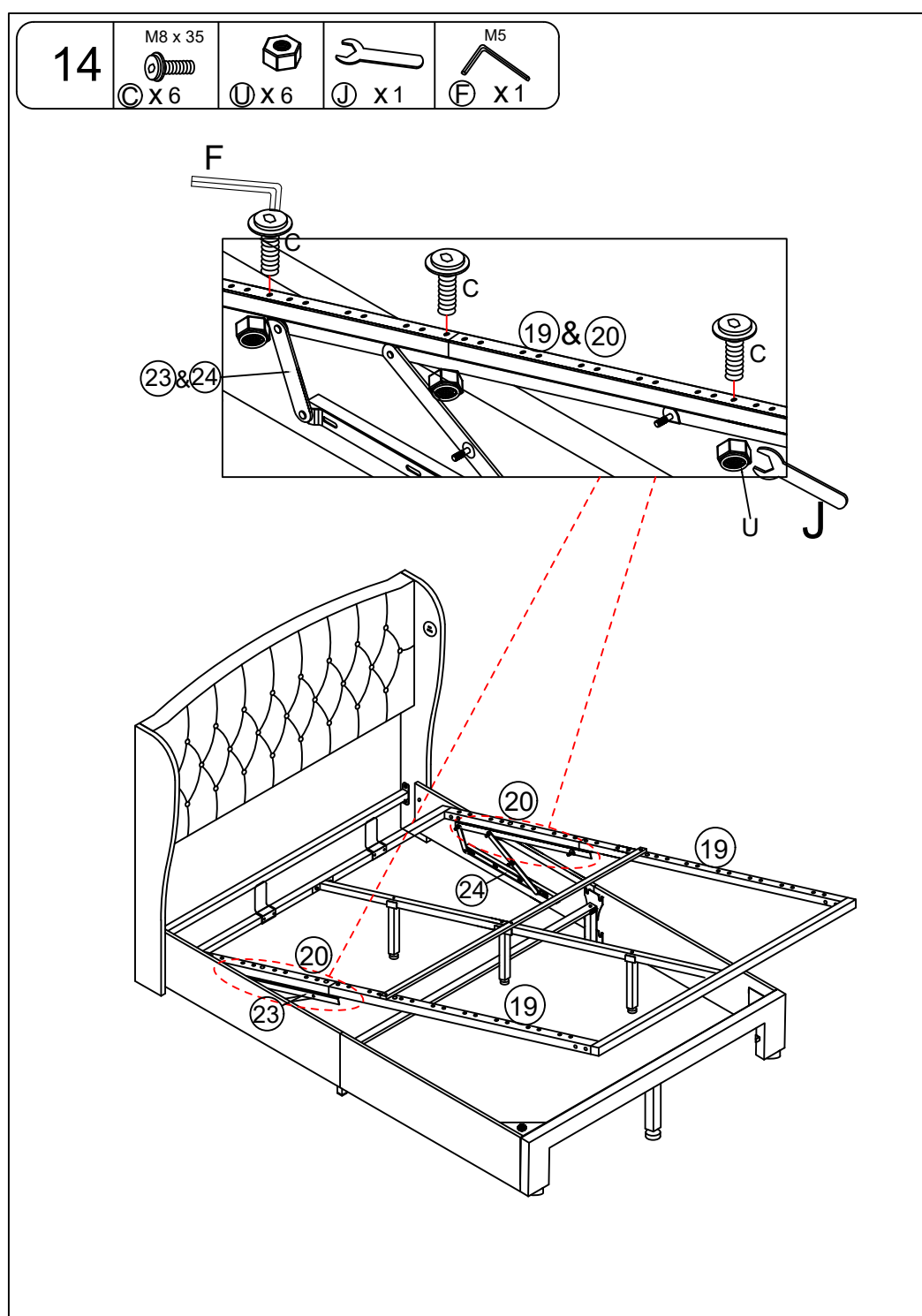
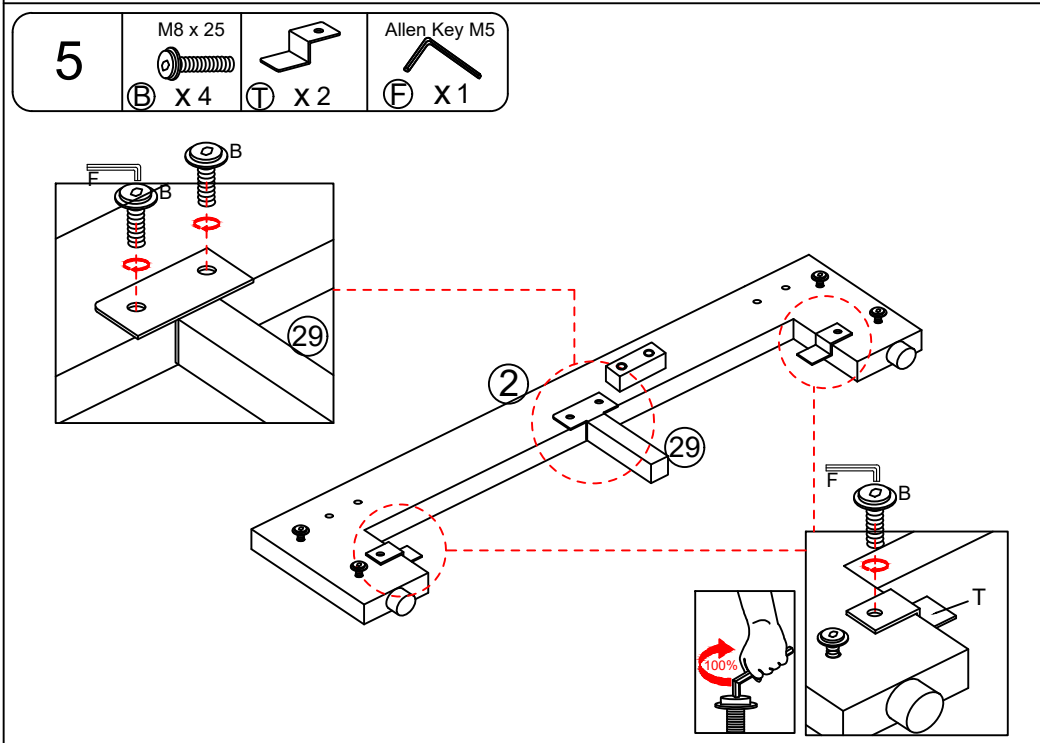
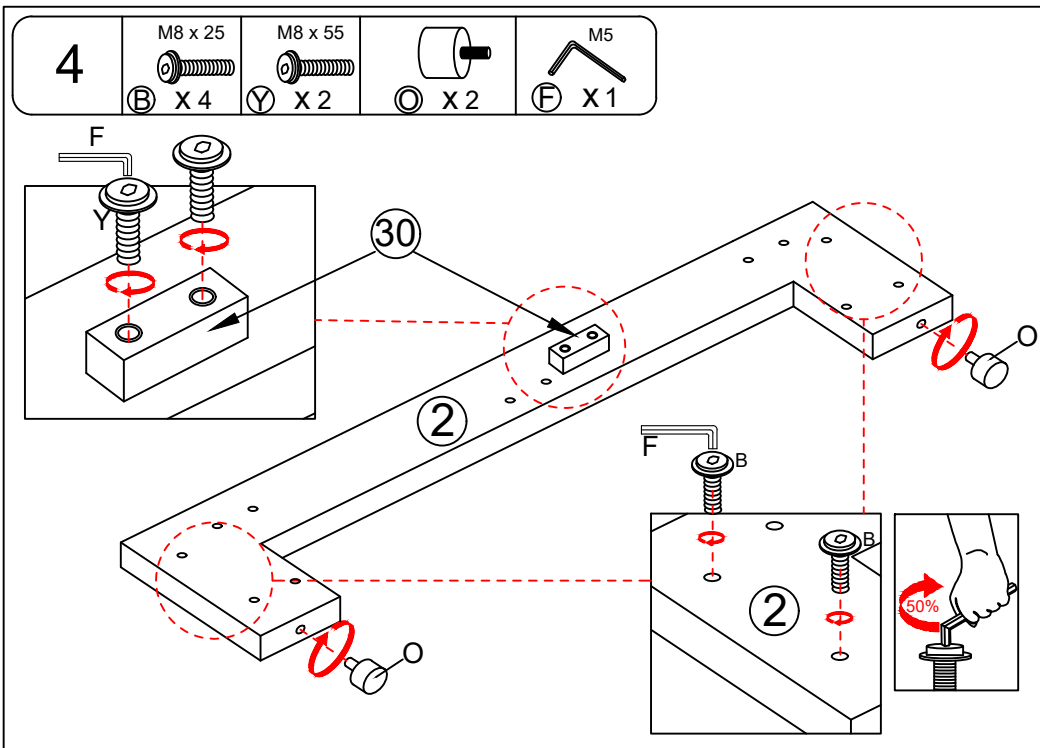

13

M8 x 40

M5

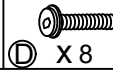

X 8

X 1

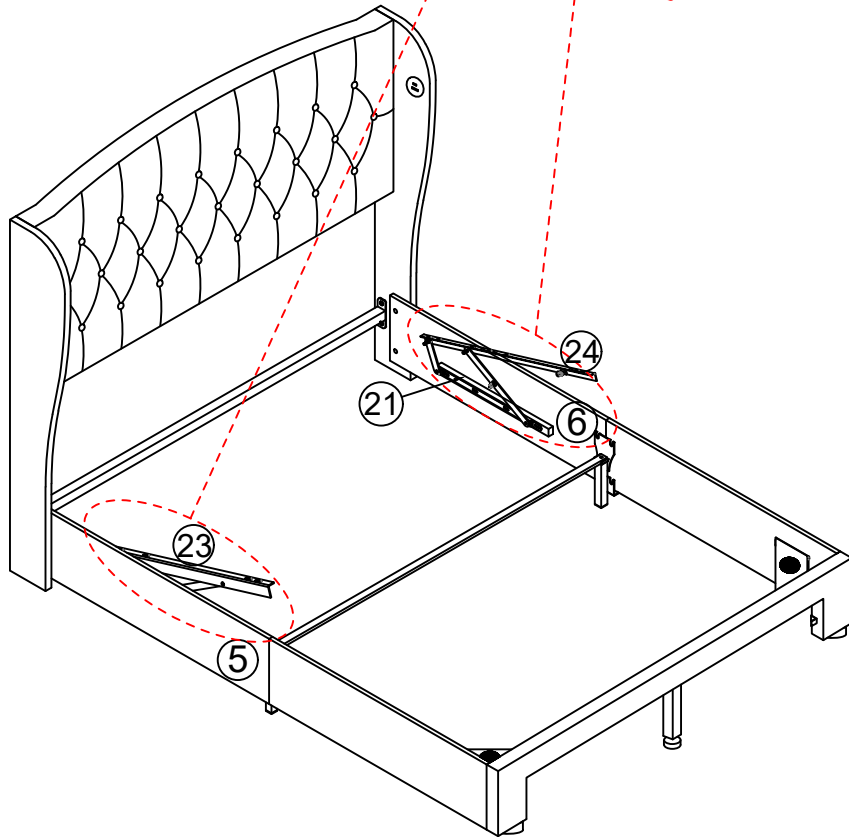
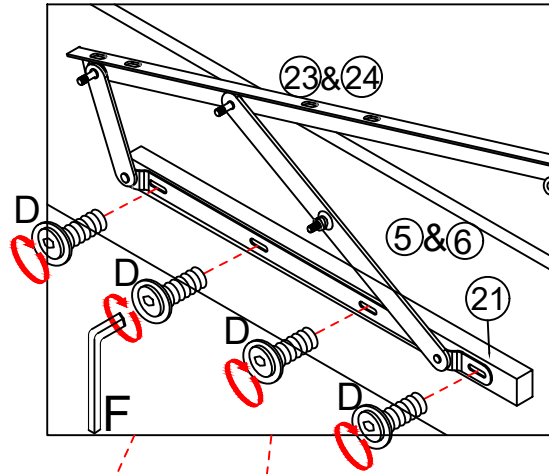
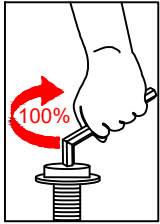

6

M8 x 45

M5

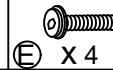

X 4

X 1

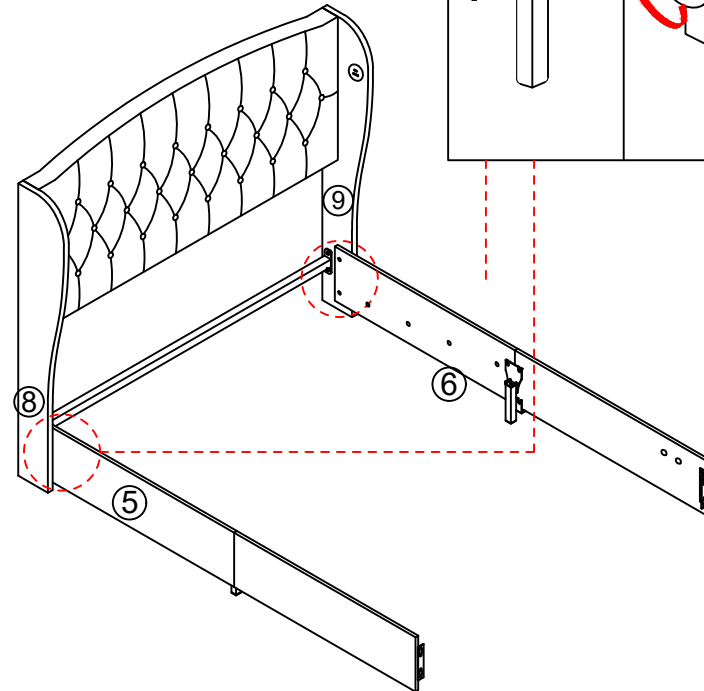
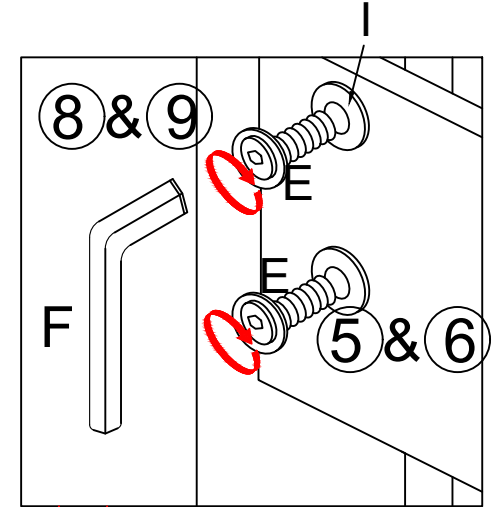

7

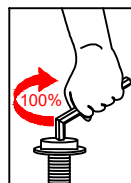
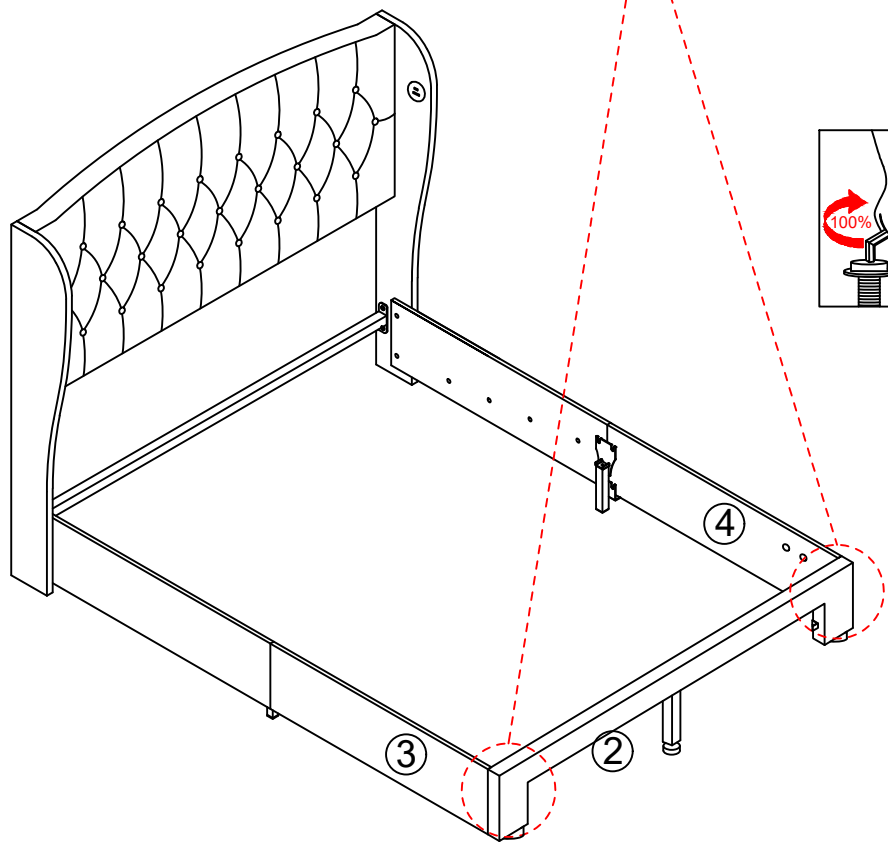
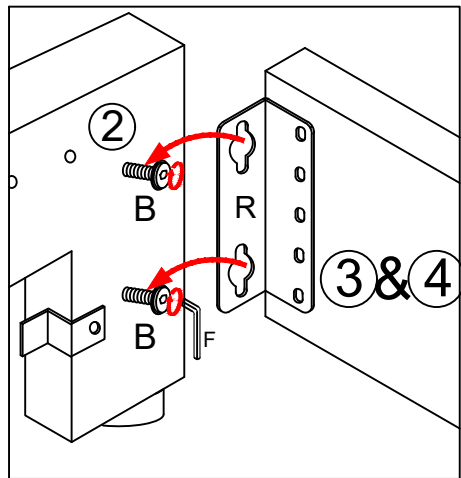
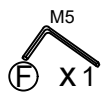

12

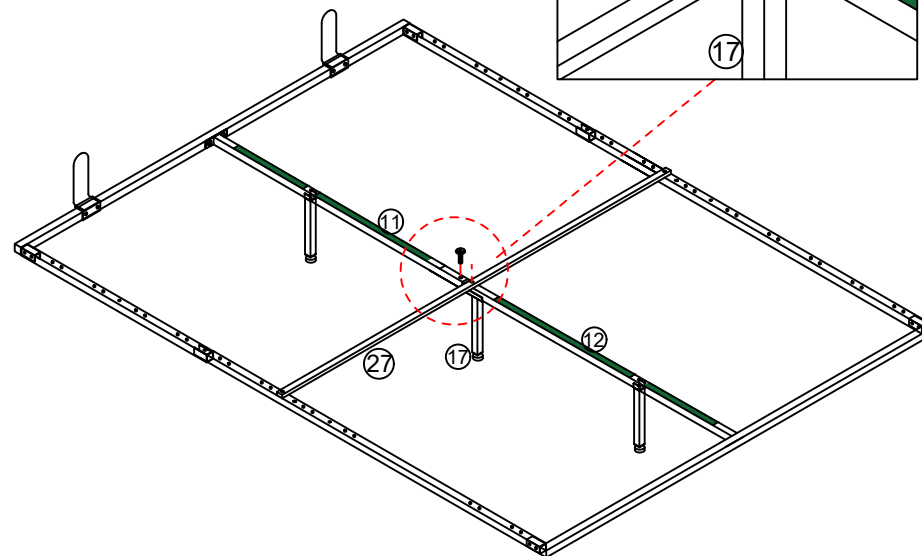
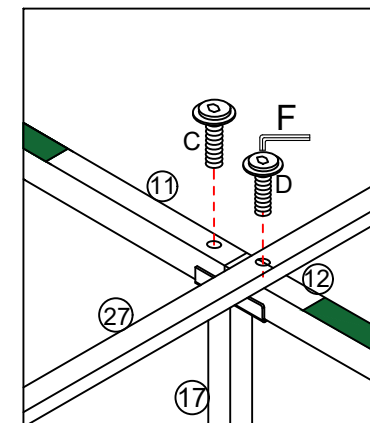
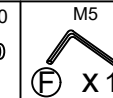
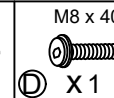
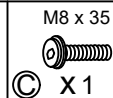

11

M8 x 18



A X 8

M8 x 35



C X 2

M5



F X 1

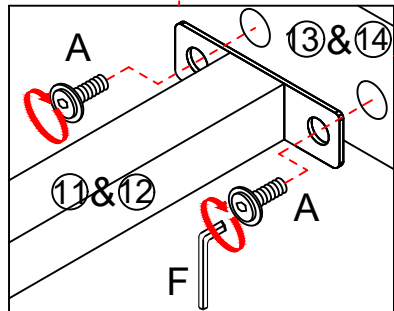
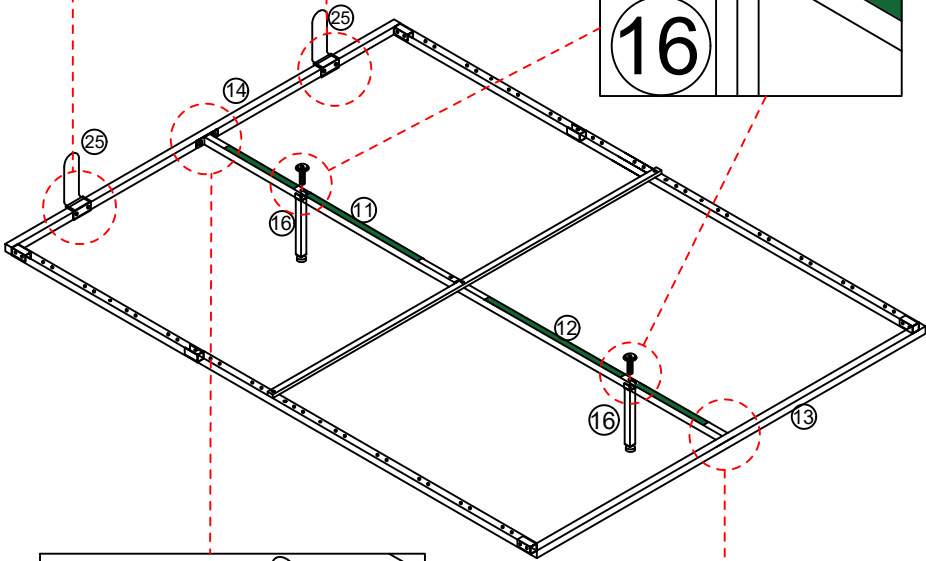
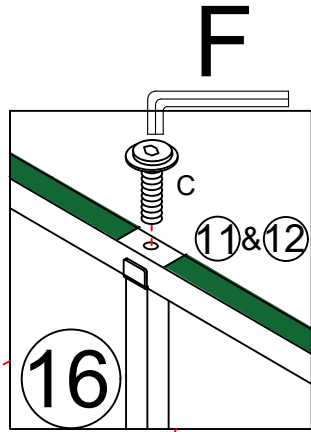
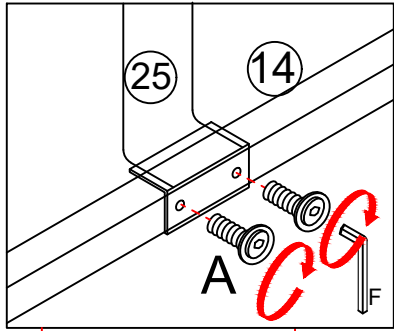

8

M8 x 35



C X 2

M5



F X 1

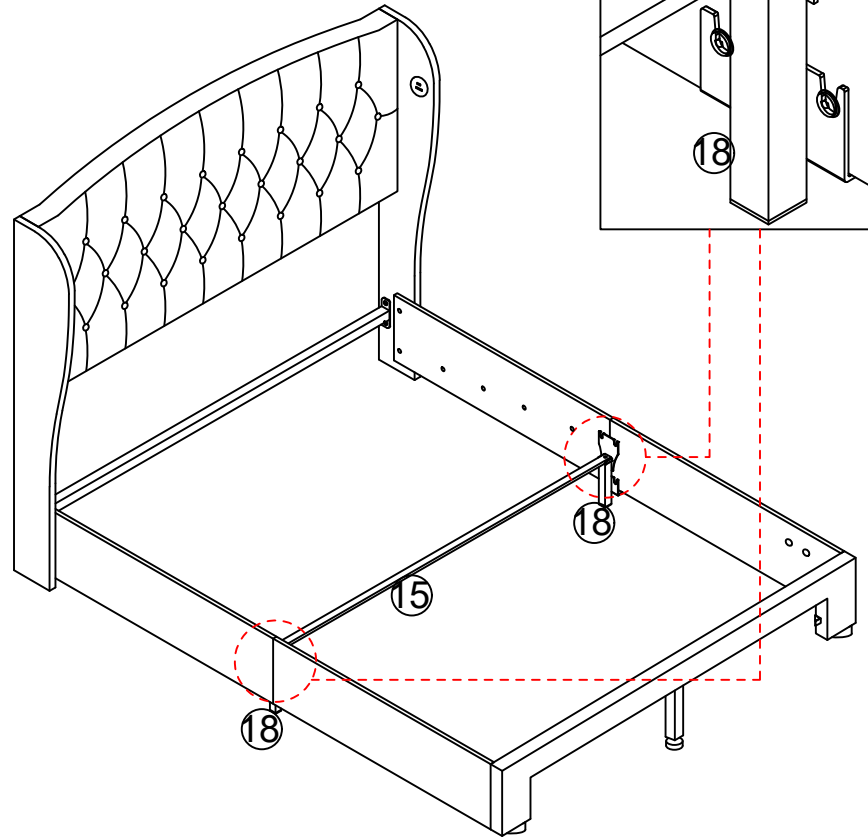
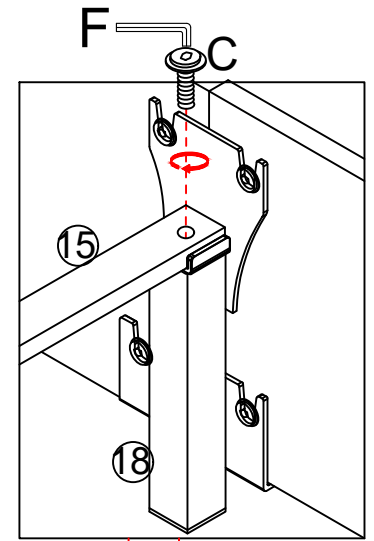

9

M8 x 18



X 8



X 2

M5



X 1

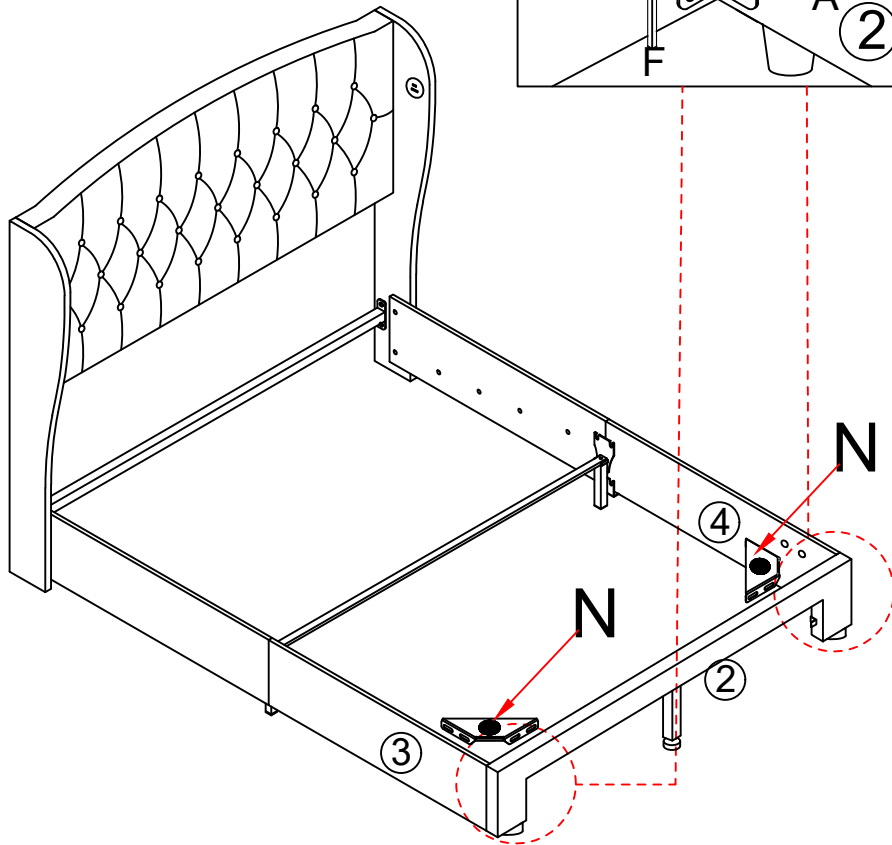
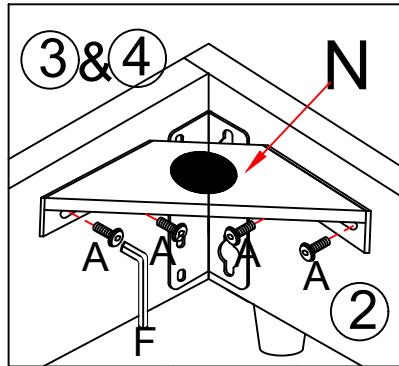
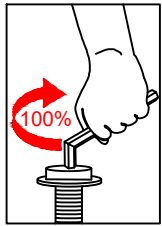

10

M8 x 25



X 2

M8 x 35



X 8



X 8



X 1

M5



X 1

