

BENCH

ASSEMBLY INSTRUCTIONS

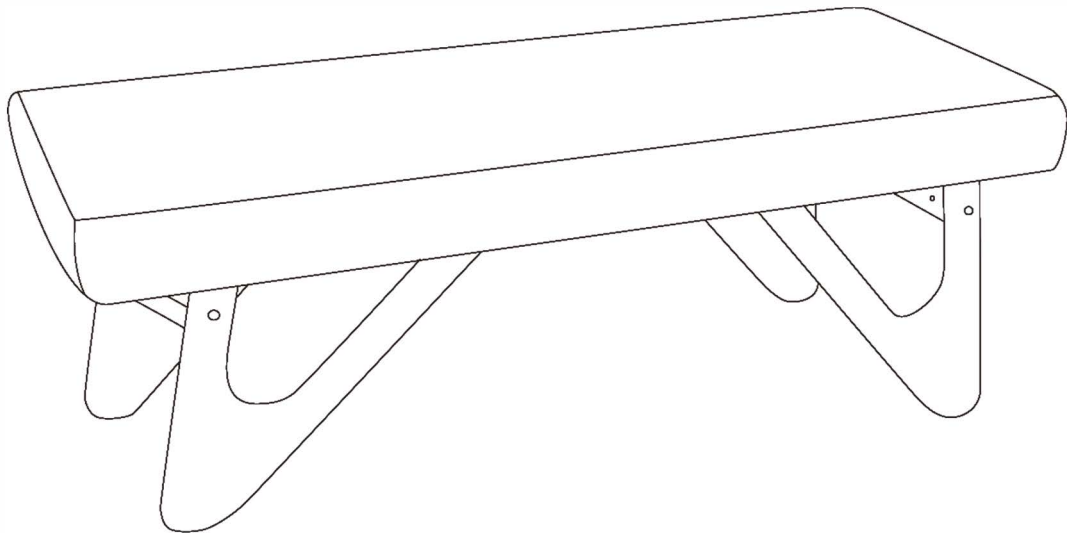

HALF HOUR
ASSEMBLY TIME

2 PEOPLE
REQUIRED FOR ASSEMBLY

1 X 1 M
FLOOR SPACE REQUIRED

INSTALLATION SUGGESTIONS

PLEASE READ ALL THE INSTRUCTIONS CAREFULLY BEFORE ASSEMBLING AND USING THE PRODUCT.







1. Please check whether all parts are complete according to the installation instructions.
2. Please ensure that the installation space is clean and flat to avoid dirt and damage to the product parts.
3. In each step, do not tighten bolts/screws completely until all bolts/screws are lined up and tightened 70% separately. Do not over tighten bolts/screws to avoid stripping.
4. We recommend that all assembled parts should be placed near the assembly location to avoid loss or forgetting while assembling.

TIPS FOR GIVING FEEDBACK

Please provide helpful information. We will give you feedback within 24h.

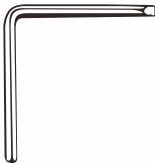
1. Describe your problem in detail and explain it with some clear multi-angle photos of the problem area.
2. Send your order ID and the letter number and quantity of the part in question from the parts list.
3. A clear photo of the side of the box that has the product information or the label on the bottom of the cushion.

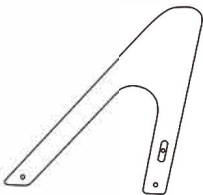
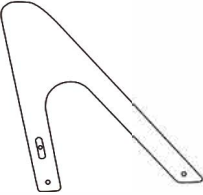
PARTS AND HARDWARE LIST

 M6*60mm A*4	 M6*40mm B*8	 C*4	 D*1
 E*1	 F*2	 G*2	 H*2

ASSEMBLY STEPS

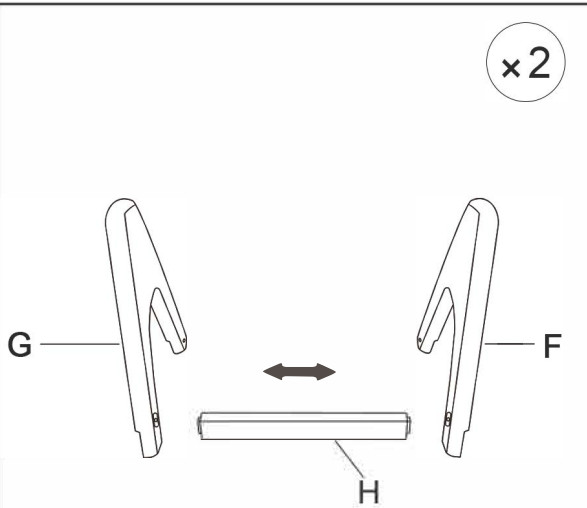

STEP 1.
Insert the wooden rod (H) into leg (F) and leg (G).

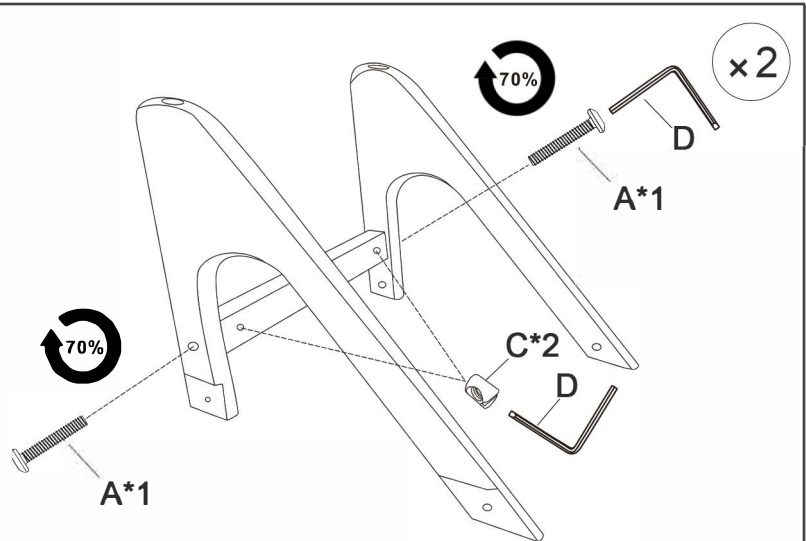

STEP 2.
Insert the nuts (C*2) into the bottom of the pre-drilled hole, and use screws (A*2) to pass through the legs and tighten them to the nuts in the wooden rod. Tip: Use a wrench to fully push the nut to the bottom of the hole, then rotate the nut until the hole on the nut aligns with the hole on the side of the wooden rod.

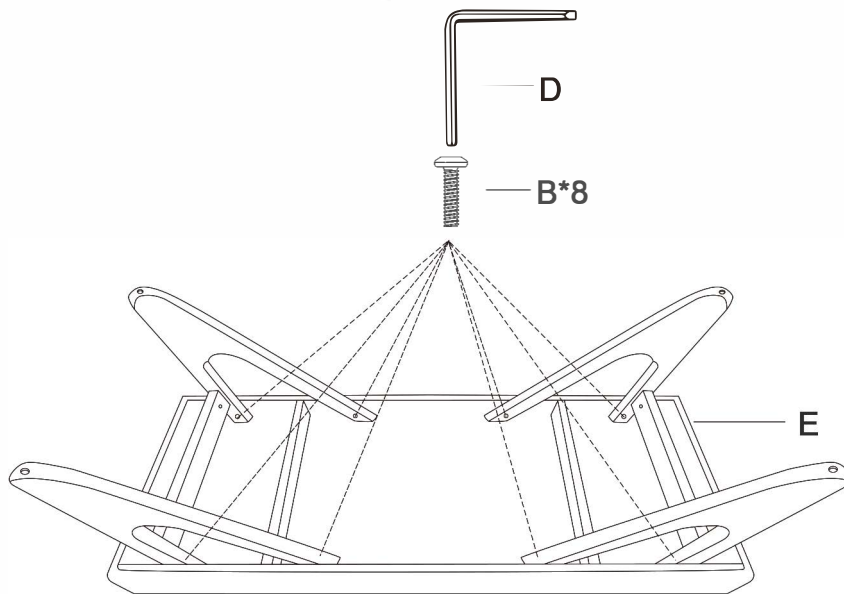

STEP 3.
Use screws (B*8) to attach the wooden legs to the seat (E).
Note: Screw them in 70% first. Once all the screws are aligned and inserted, tighten all the screws one by one.

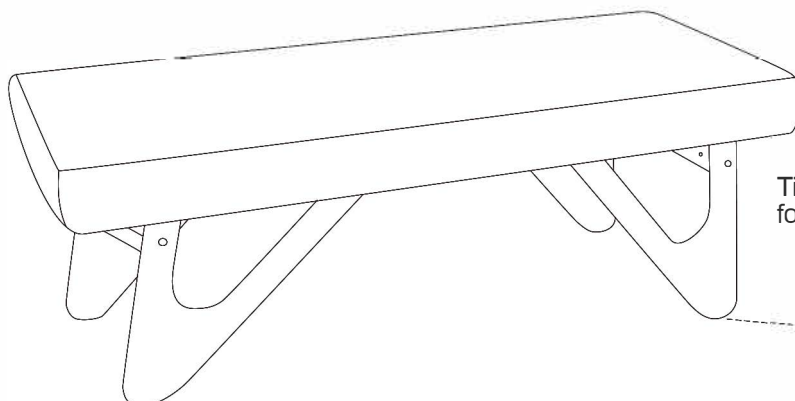

Tip: Adjust pre-installed adjustable foot pads height to achieve balance.

STEP 4.
Congratulations ! You have possessed an exquisite bench.

WARRANTY TERMS & CONDITIONS

1. We provide warranty for the product for one year.
2. The warranty period starts on the delivery date.
3. If the product has quality problems, contact us and we promise we will solve it for you.

FABRIC MAINTENANCE TIPS

Stripe in the fabric? This can be caused by the pressure exerted on the fabric by the packaging. Fortunately, you can easily solve this yourself by steaming the fabric (use your **steam iron**, for example) or by spraying it with moisture. Then you can brush the fabric with a **clean soft brush**. The piles of the fabric will be repaired in this way!

