

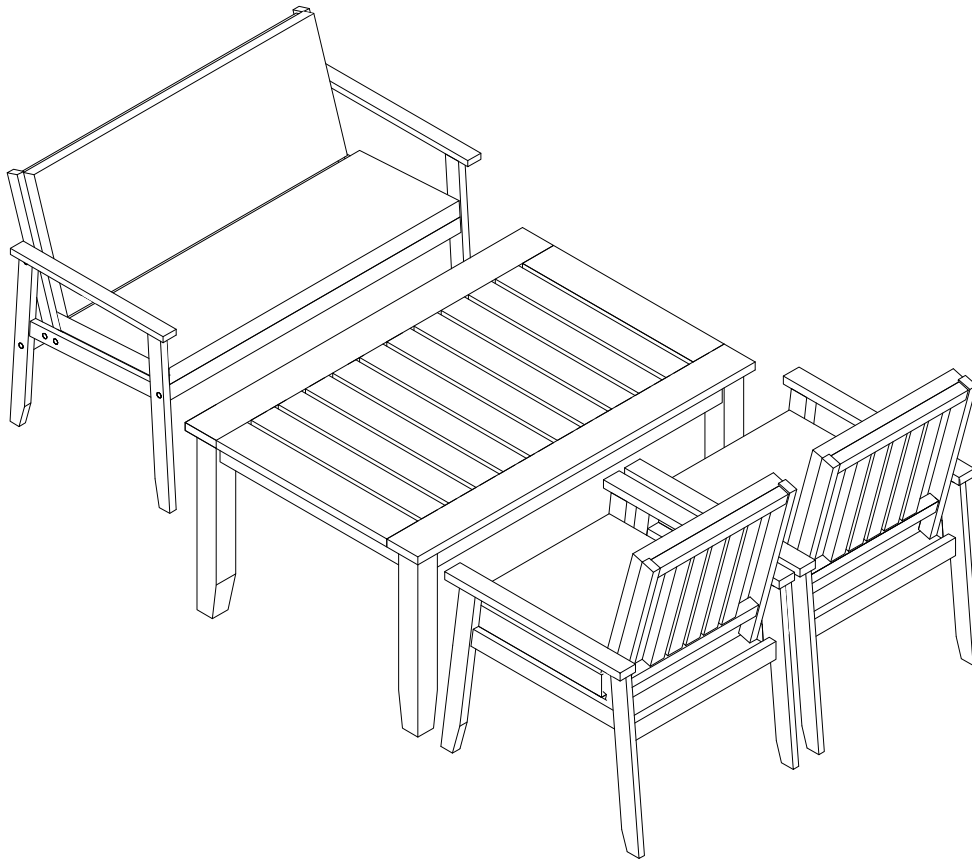

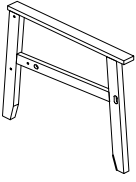

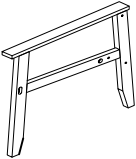

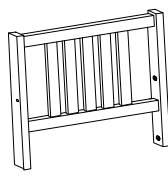
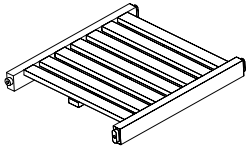
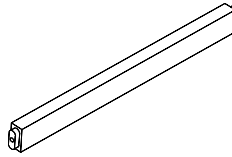
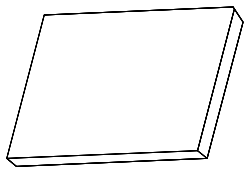
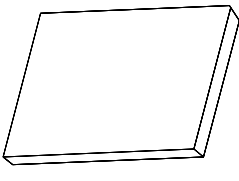
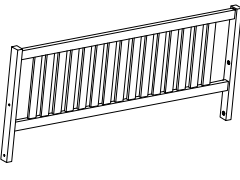
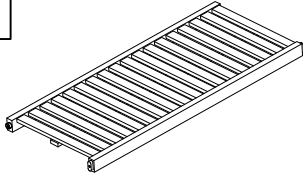
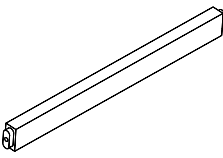
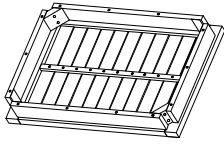

# ASSEMBLY INSTRUCTIONS

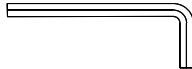

- 1.** To begin assembly, make sure you're working on a flat, level surface throughout the assembly process. This will ensure a strong and stable final product.
- 2.** Tighten all screws throughout lightly with the Allen wrench. Be sure each screw is aligned properly with their corresponding holes.
- 3.** Once every component is loosely assembled, go back and tighten all of the screws gradually & firmly. This ensures each component is seated properly and prevents warping.
- 4.** Be sure to give the furniture a wobble test once complete. If it feels unsteady, loosen all of the screws again on a flat surface, and repeat steps 2 & 3.
- 5.** All holes meant for adjustments are designed to be larger, ensuring a perfect fit.

<p><b>A</b></p>  <p>Left Armrest (3pcs)</p>	<p><b>B</b></p>  <p>Right Armrest (3pcs)</p>	<p><b>C</b></p>  <p>Single Back (2pcs)</p>
<p><b>D</b></p>  <p>Single Seat (2pcs)</p>	<p><b>E</b></p>  <p>Leg Support (2pcs)</p>	<p><b>H</b></p>  <p>Single Seat Cushion (2pcs)</p>
<p><b>J</b></p>  <p>Single Back Cushion (2pcs)</p>	<p><b>K</b></p>  <p>Double Back (1pc)</p>	<p><b>L</b></p>  <p>Double Seat (1pc)</p>
<p><b>M</b></p>  <p>Double Leg Support (1pc)</p>	<p><b>N</b></p>  <p>Table Top (1pc)</p>	<p><b>G</b></p>  <p>Table Leg (4pcs)</p>
<p><b>P</b></p>  <p>Double Seat Cushion (1pc)</p>	<p><b>Q</b></p>  <p>Double Back Cushion (1pc)</p>	<p><b>1</b></p>  <p>M6 x 60 (18pcs)</p>
<p><b>2</b></p>  <p>M6 x 40 (set of 6)</p>	<p><b>3</b></p>  <p>M6 x 30 (set of 6)</p>	<p><b>4</b></p>  <p>Allen Key (2pcs)</p>
<p><b>5</b></p>  <p>M8 x 13 (8pcs)</p>	<p><b>6</b></p>  <p>Washer (8pcs)</p>	<p><b>7</b></p>  <p>Wrench (1pcs)</p>

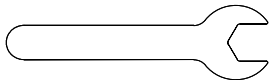
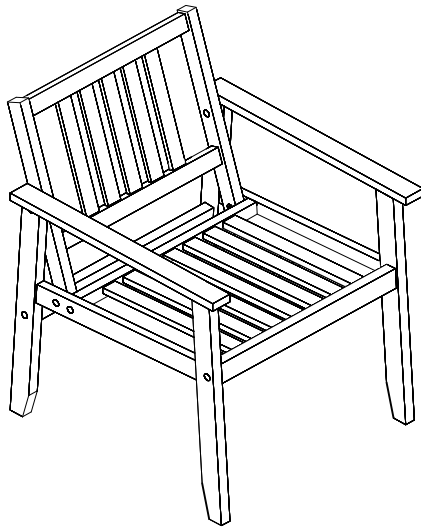

**Step 1**

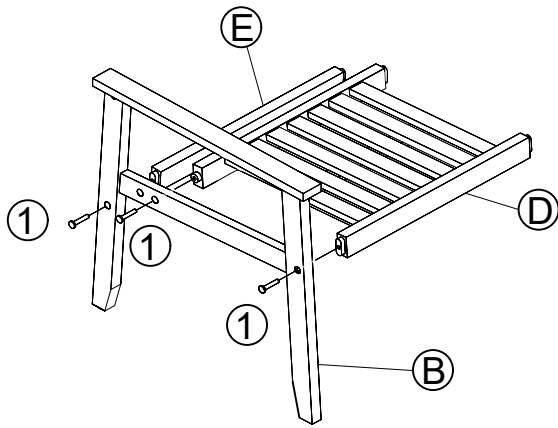

**Step 2**

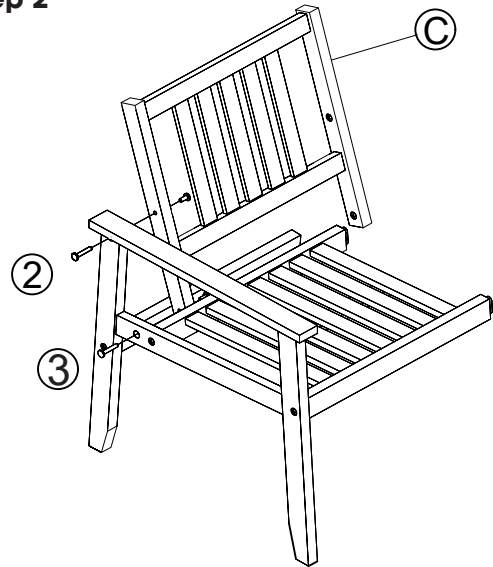

**Step 3**

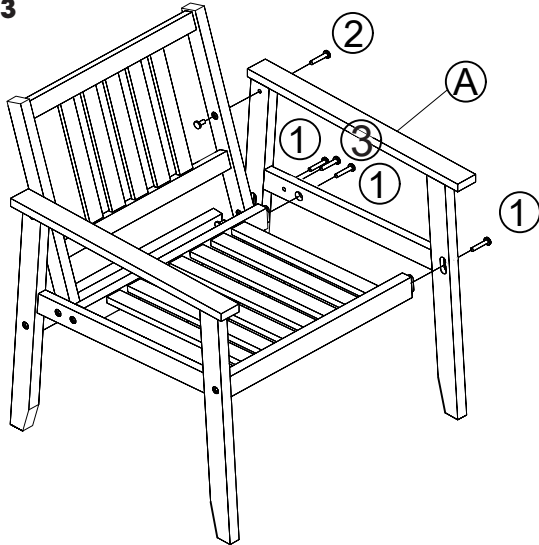

**Step 4**

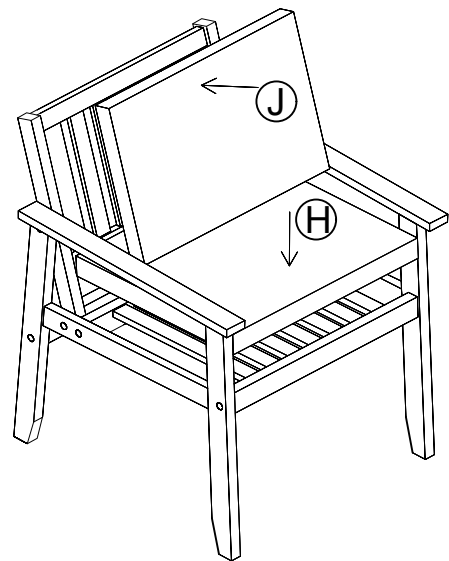

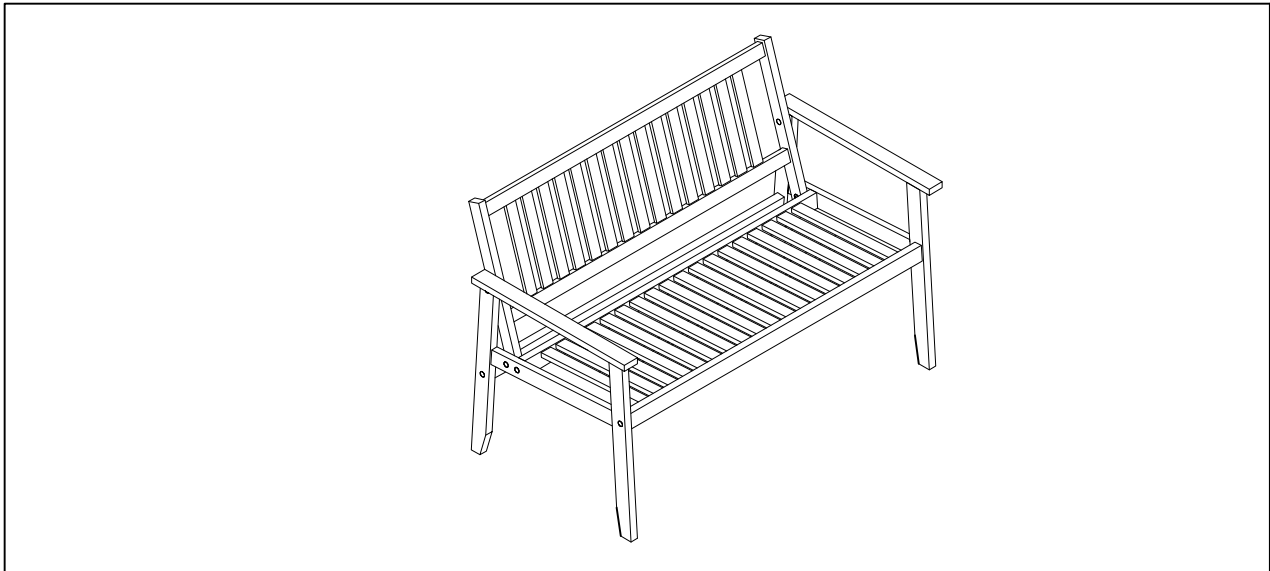

**Step 1**

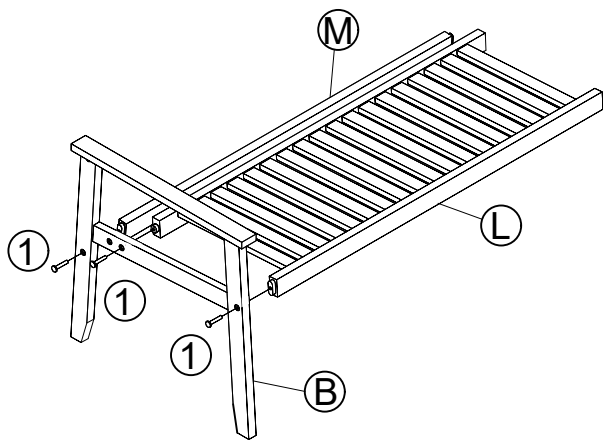

**Step 2**

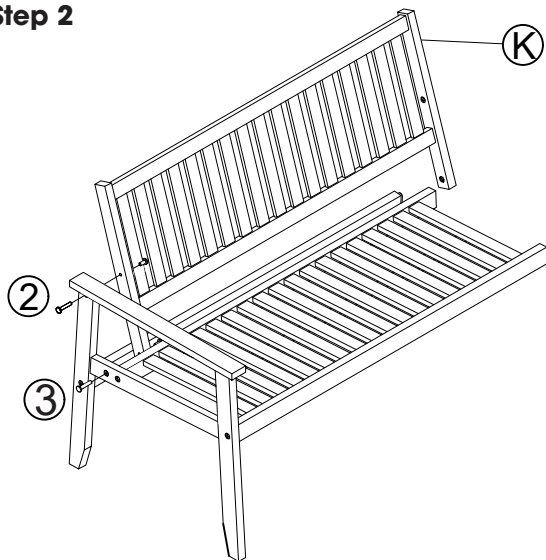

**Step 3**

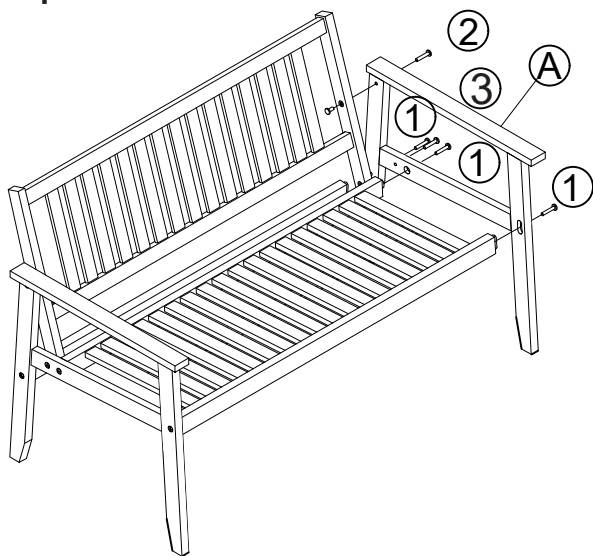

**Step 4**

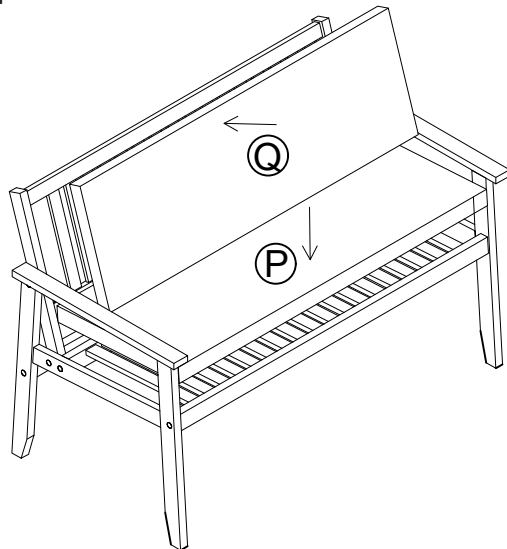

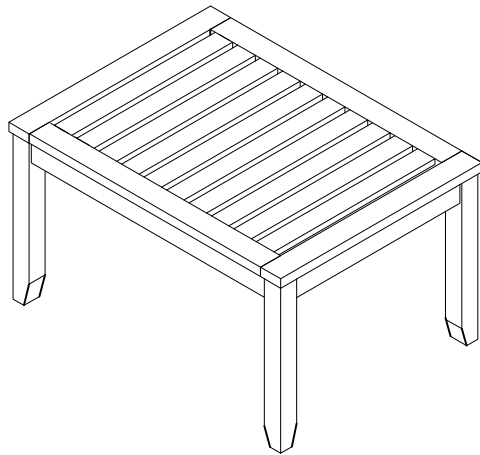

**Step 1**

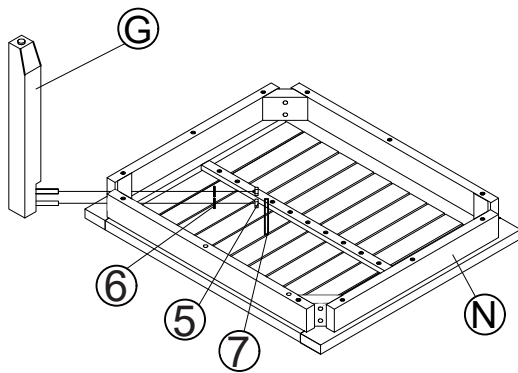

**Step 2**

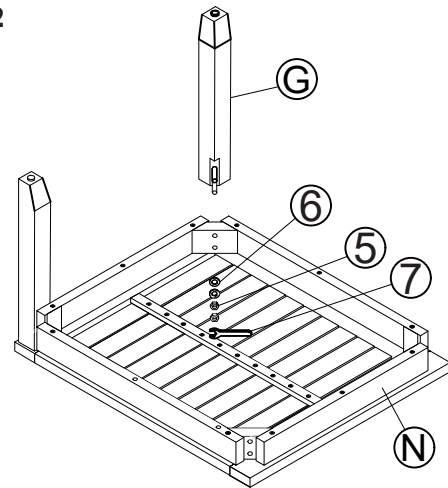

**Step 3**

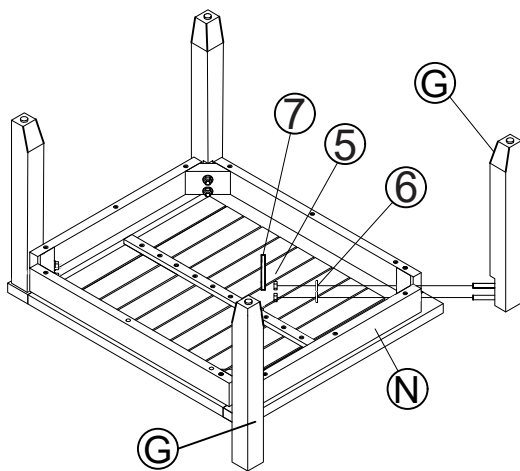

**Step 4**

