

USER'S MANUAL

5 Pcs Dining Set

THIS INSTRUCTION BOOKLET CONTAINS **IMPORTANT** SAFETY INFORMATION. PLEASE READ AND KEEP FOR FUTURE REFERENCE.

Please give us a chance to make it right and do better!

Contact our friendly customer service department for help first.
Replacements for missing or damaged parts will be shipped ASAP!

FLOOR AREA
2MX2M

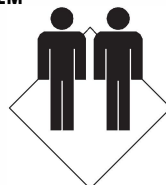

ASSEMBLED BY 2 ADULTS

Contact Us!

Do NOT return this item.

Contact our friendly customer service department for help first.

Before You Start



- ⚠ Read each step carefully before starting. It is very important to ensure each step followed in correct order, otherwise assembly difficulties may occur.
- ⚠ Most of board parts are labeled or stamped on the raw edges. Have a check to make sure all parts are included.
- ⚠ Work in a spacious area, preferably on a carpet close to where the unit will be used .
- ⚠ Keep the handtools close at hand. Do not use power tools to assemble your furniture. They may scratch or damage the parts.

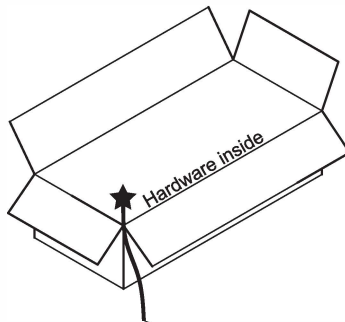

Board Identification

Not actual size

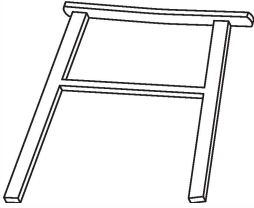

Left Arm x 4

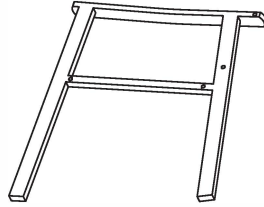

Right Arm x 4

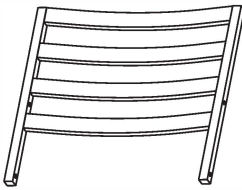

Back x 4

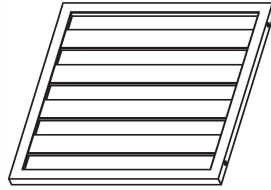

Seat x 4

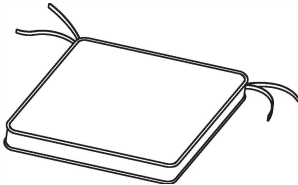

Cushion x 4

Board Identification

Not actual size

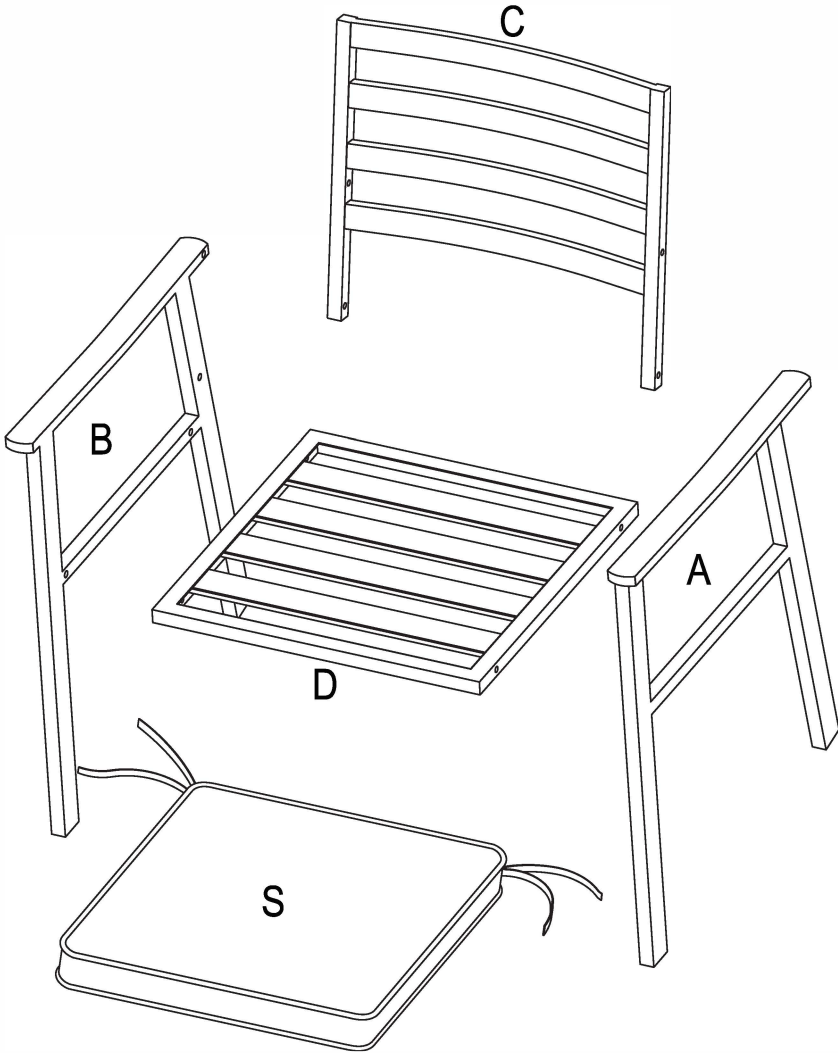

Hardware List

Actual size

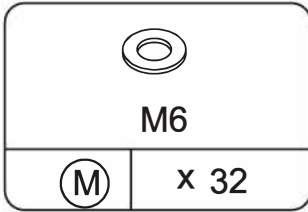

WASHER

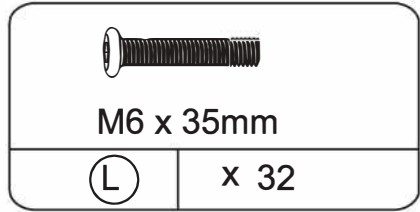

BOLT

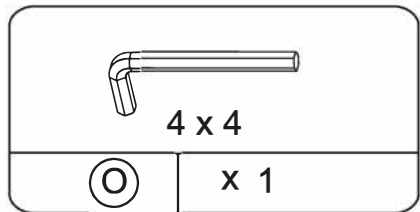

ALLEN WRENCH

STEP 1

Attach the seat (D) to the arm (B) by inserting bolts (L) with washers (M) through the pre-drilled holes on the seat into the pre-welded nuts on the arm. Repeat step for the other side arm (A)

IMPORTANT: Do not tighten completely until assembly is completed.

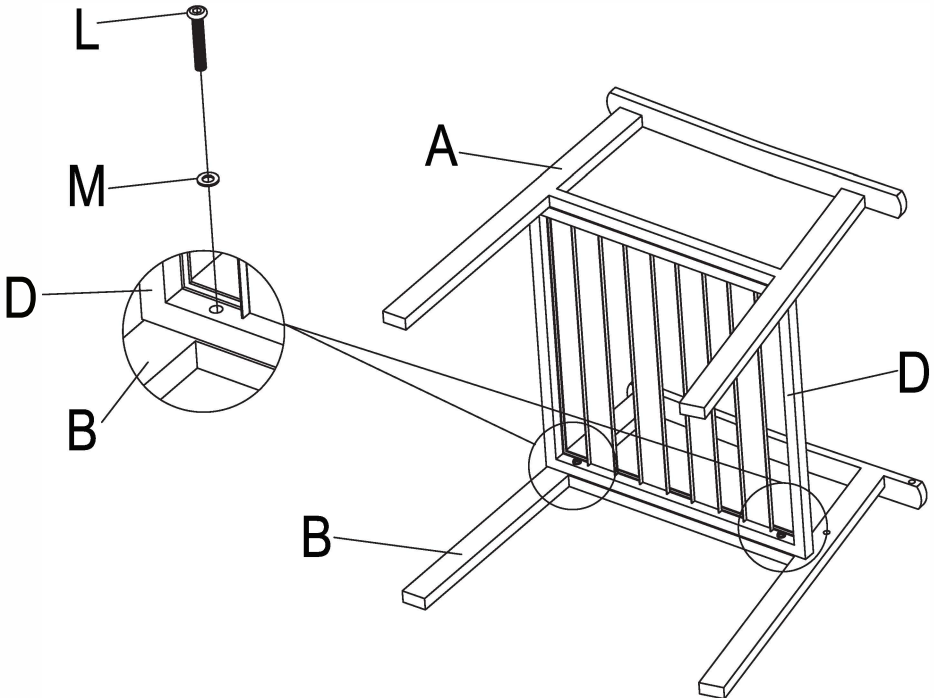

STEP 2

Attach the back(C) to the arm (A&B) by inserting bolts (L) with washers (M).

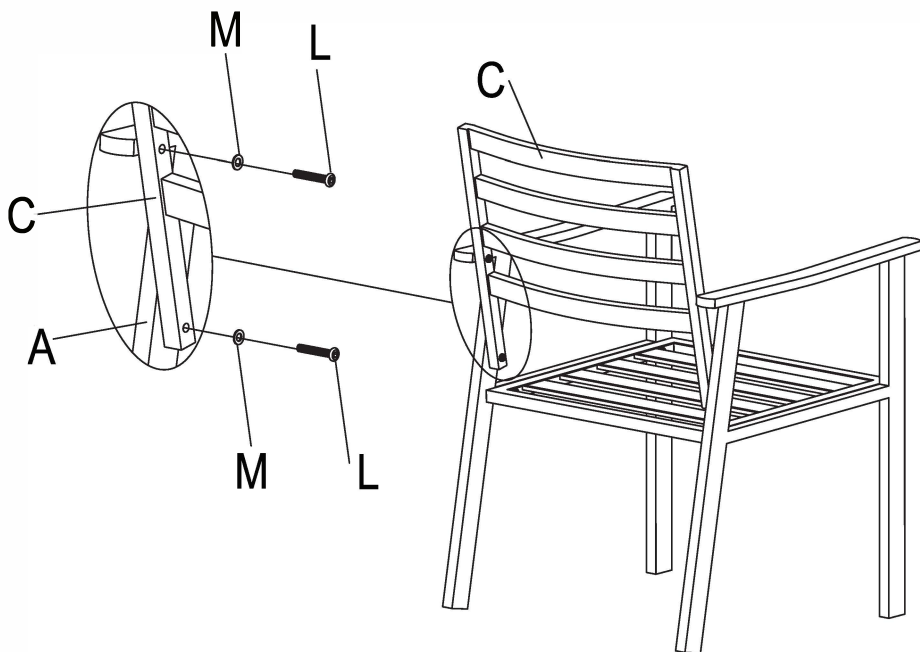

STEP 3

Tighten all the bolts with the allen wrench, and turn the chair to the upright position. place the cushions(S) onto the chair seat. Your chair is now ready for use.

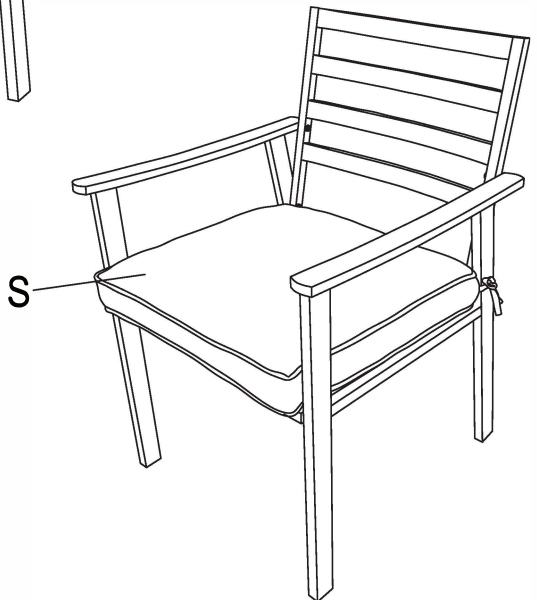
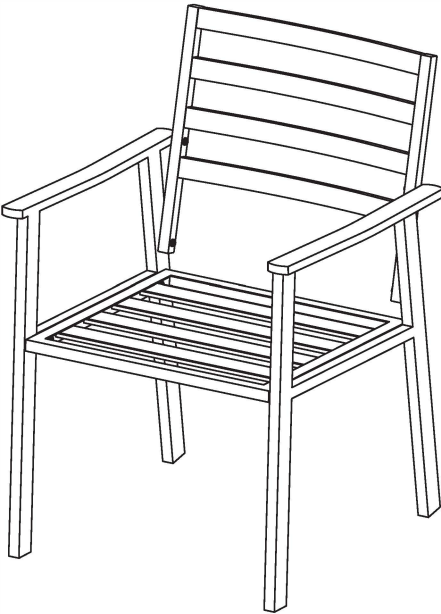

Maximum Loads

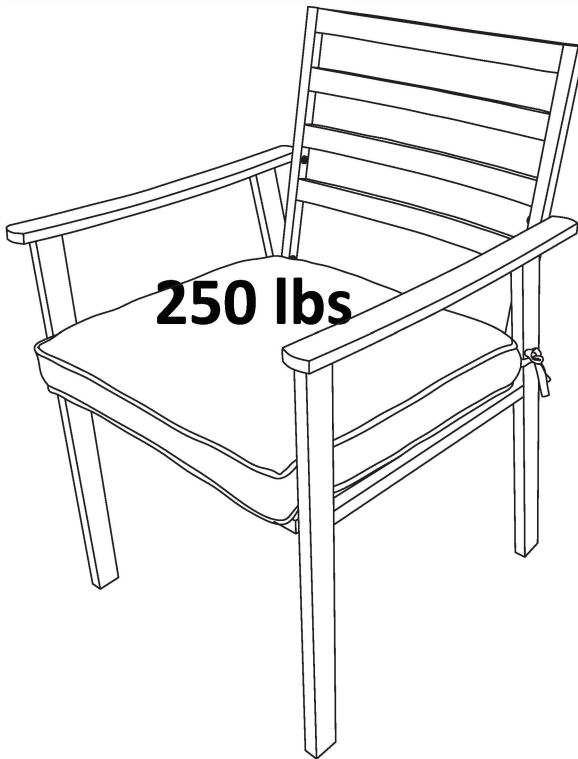

⚠ WARNING

This item is only suitable within the specified maximum load-bearing. Heavier loads than the indicated load capacity may cause instability, resulting in possible injuries.

Board Identification

Not actual size

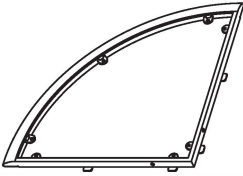

Table Frame E x 2

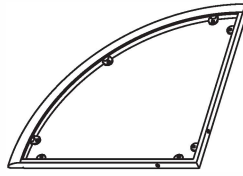
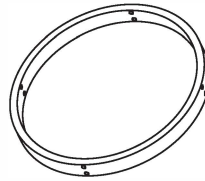

Table Frame F x 2



Table Leg x 4



Leg Brace x 1

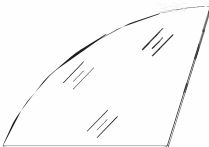

Glass x 4

Board Identification

Not actual size

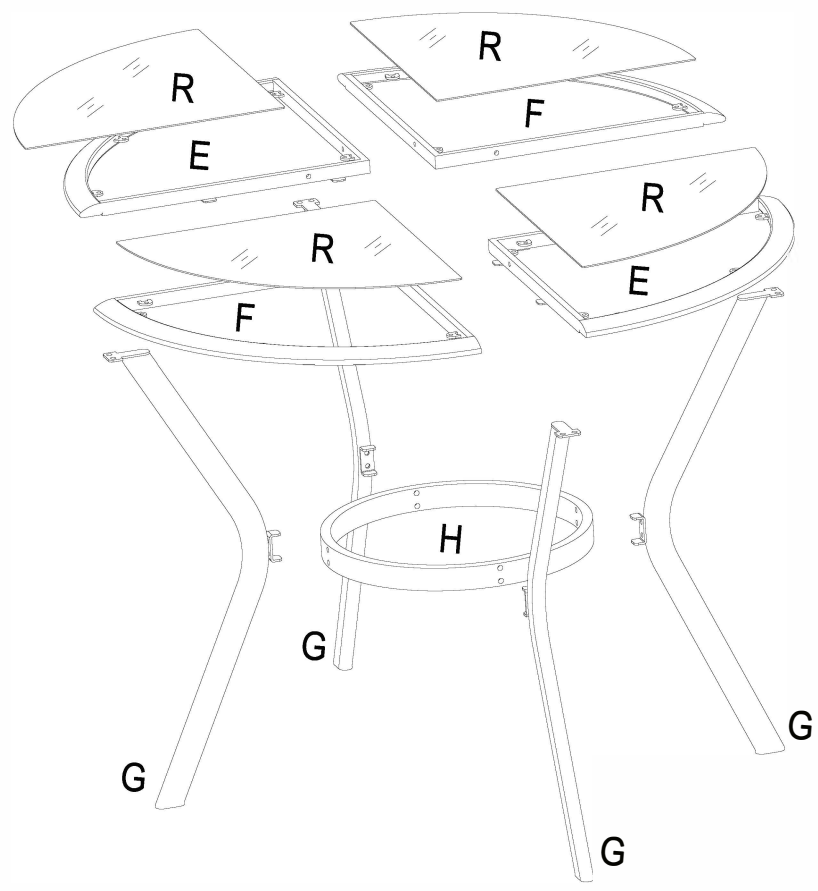

Hardware List

Actual size

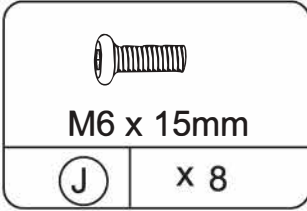

BOLT

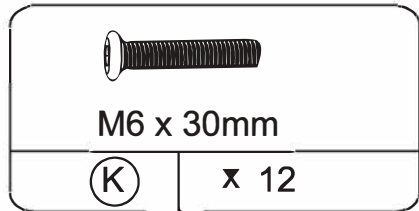

BOLT

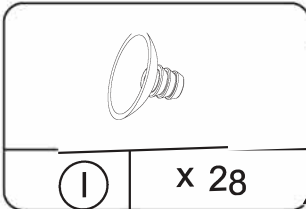

Rubber Spacer

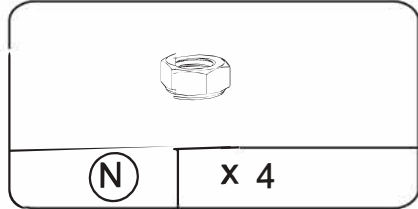

NUTS

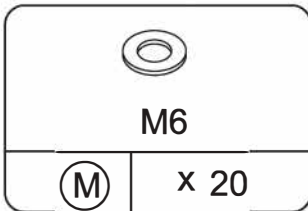

WASHER

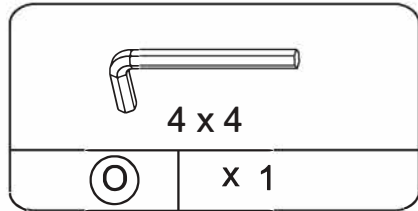

ALLEN WRENCH

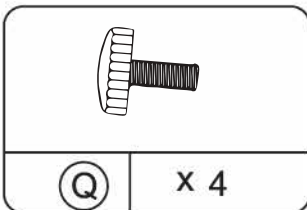

ADJUSTABLE
LEVELLERS

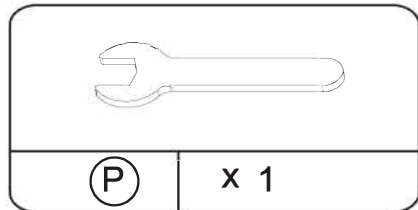

WRENCH

STEP 1

Attach the table frame (E) to the table frame (F) by inserting bolts (K) with washers (M),nuts(N).

IMPORTANT:Do not tighten completely until assembly is completed.

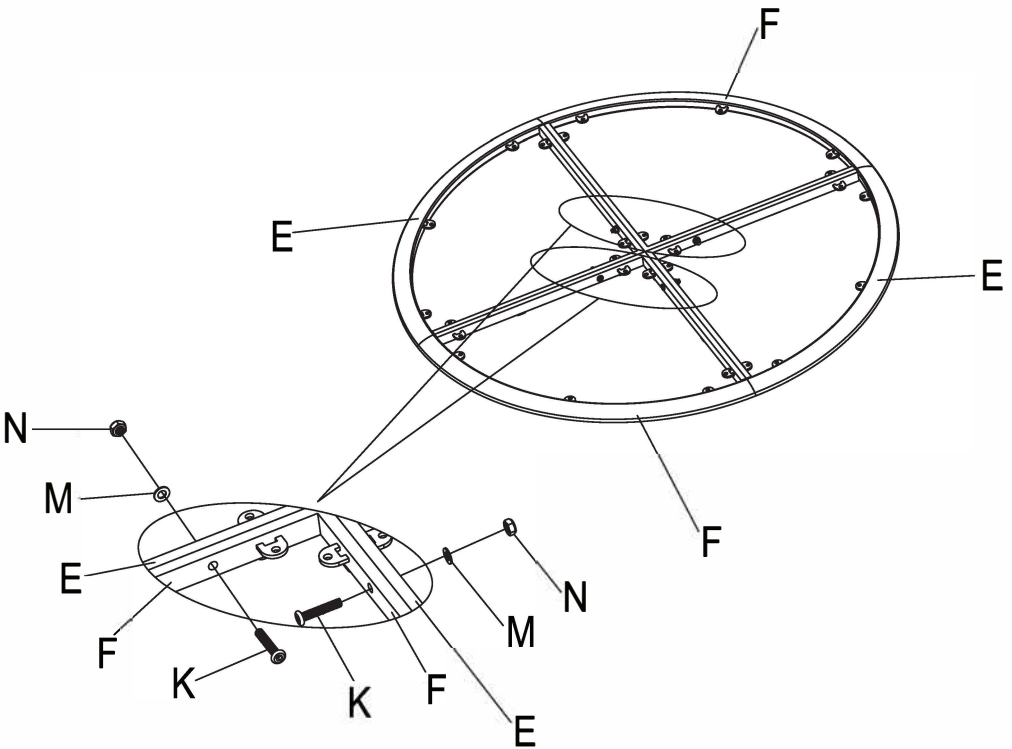

STEP 2

Attach the table leg (G) to the table frame (E&F) by inserting bolts (J) with washers (M).

Insert adjustable levellers(Q) to bottom of each table leg(G) by turning clockwise until secure.

Adjust height as desired.

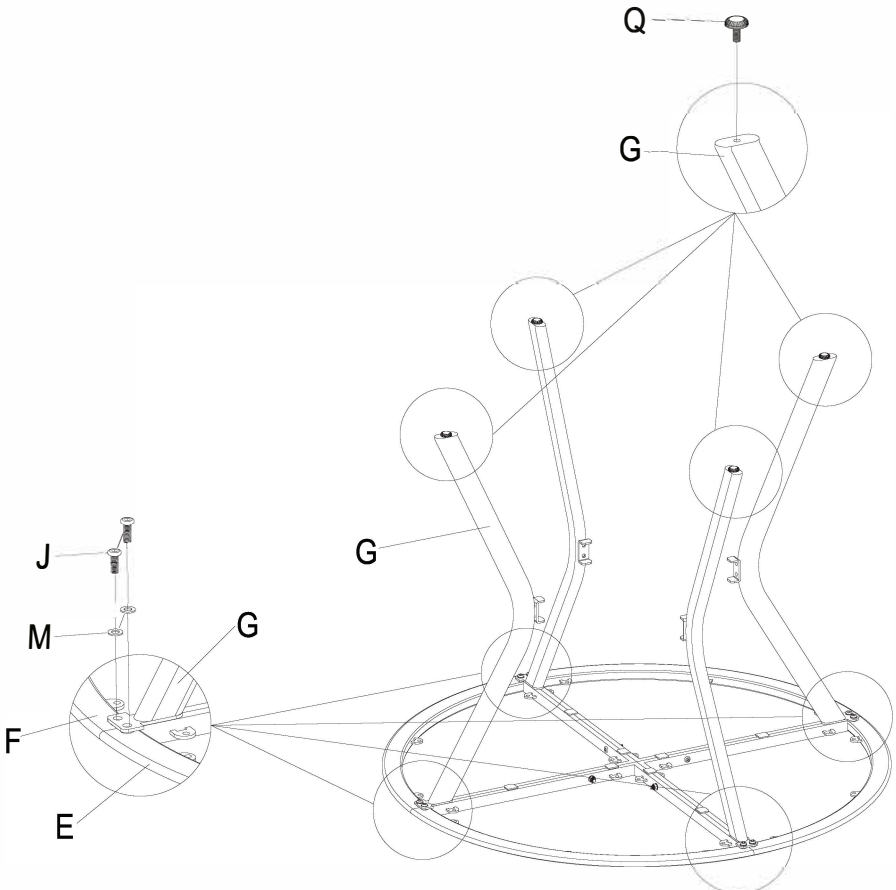

STEP 3

Attach the leg brace (H) to the table leg (G) by inserting bolts (K) with washers (M).

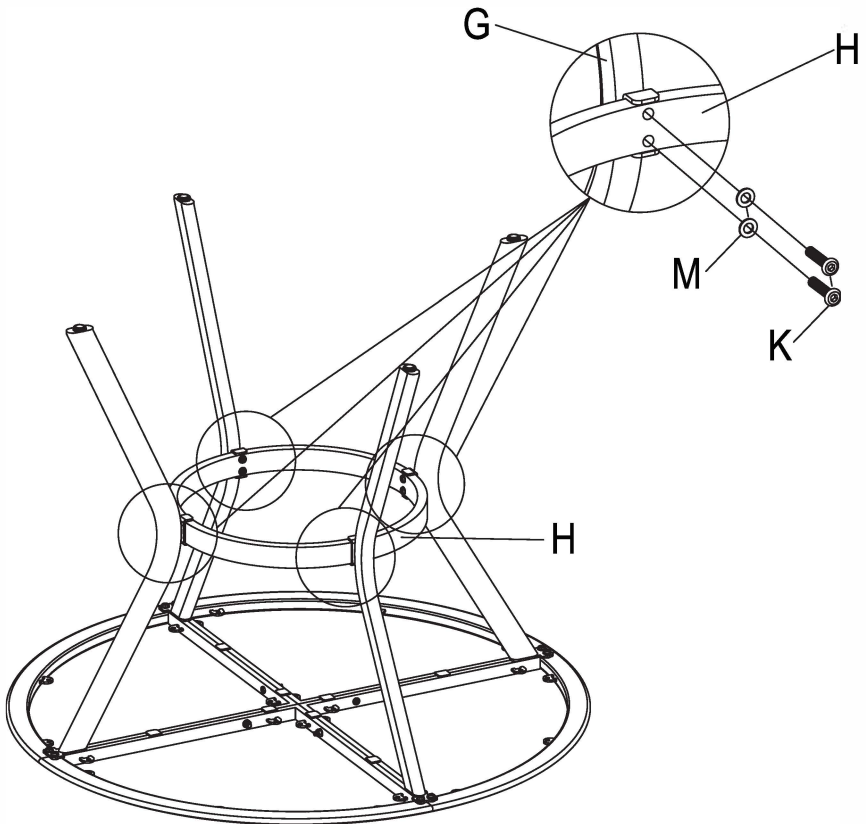

STEP 4

Attach the Rubber Spacer (I) to the table frame(E&F).

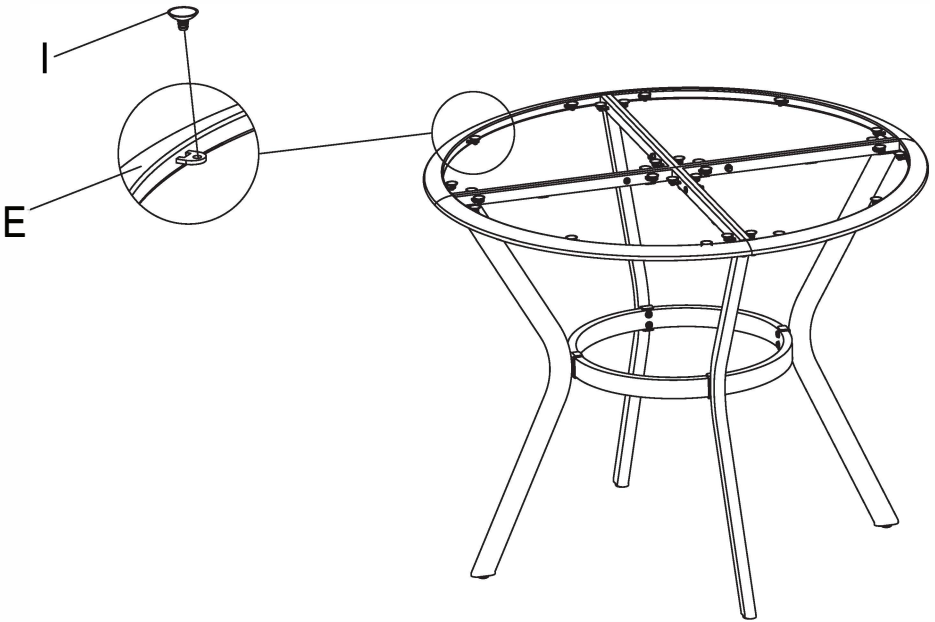

STEP 5

Tighten all the bolts with the allen wrench,
and turn the table to the upright position.
Put the glass on the the table frame.
Your table is now ready for use.



Maximum Loads

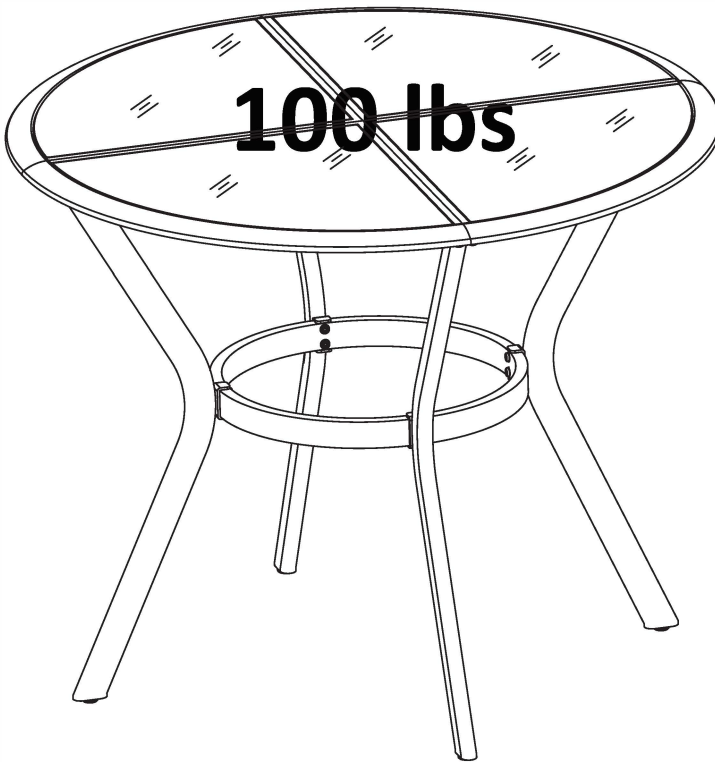

⚠ WARNING

This item is only suitable within the specified maximum load-bearing. Heavier loads than the indicated load capacity may cause instability, resulting in possible injuries.

Care and Maintenance

Use a soft, clean cloth that will not scratch the surface when dusting.

Use of furniture polish is not necessary.

Should you choose to use polish, test first in an inconspicuous area.

Using solvents of any kind on your furniture may damage the finish.

Never use water to clean your furniture as it may cause damage to the finish.

Liquid spills should be removed immediately. Using a soft clean cloth, blot the spill gently. Avoid rubbing.

Check bolts/screws periodically and tighten them if necessary.

Further advice about wood furniture care

Please protect your outdoor furniture with a cover when not in use since Long-term sunlight exposure will result in the damage on the surface.

In addition to sunlight damage, wood and metal frame suffers when exposed to extremes in temperature and humidity.

Proper care and cleaning at home will extend the life of your purchase.

Following these important and helpful tips will enhance your furniture as it ages.