

Brand-Man COLT Portable Charcoal Rotisserie Grill BMROTIS

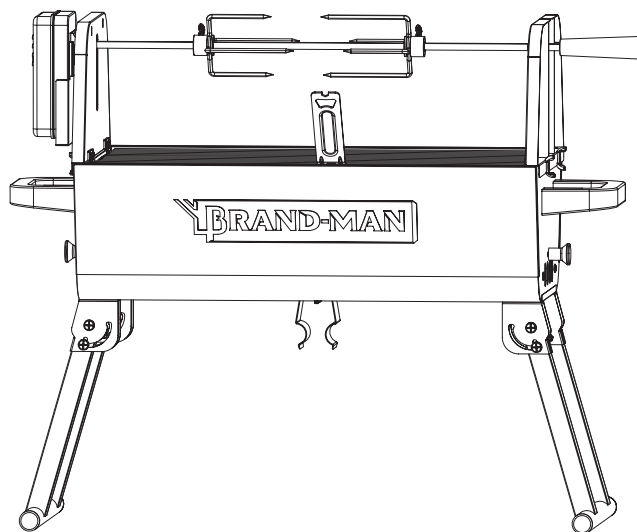

Keep this manual for future reference.

This instruction manual contains important information necessary for the proper assembly and safe use of the appliance.

Read and follow all warnings and instructions before assembling and using the appliance.

Follow all warnings and instruction when using the appliance

DANGER

Never operate this appliance unattended.

WARNING

CALIFORNIA PROPOSITION 65 WARNING:

- (a) The burning of Charcoal cooking fuel generates some by products which are on the list of substances known by the State of California to cause cancer, reproductive harm, or other birth defects. To reduce exposure to these substances, always operate this unit according to the use and care manual, ensuring you provide good ventilation when cooking with Charcoal.
- (b) Handling the brass material on this product exposes you to lead, a chemical known to the State of California to cause cancer and birth defects or other reproductive harm. Wash hands after handling.
- (c) This product contains chemicals, including lead and compounds, known by the State of California to cause cancer, reproductive harm, or other birth defects.
- (d) Wash your hands after using this product.

For more information go to: www.P65Warnings.ca.gov

 **WARNING**
FOR YOUR SAFETY:
For Outdoor Use Only
(Outside any enclosure)

-  **WARNING**
FOR YOUR SAFETY:
- Improper Installation, adjustment, alteration, service or maintenance can cause injury or property damage.
 - Read the installation, operation, and maintenance instructions thoroughly before installing or servicing this equipment.
 - Failure to follow these instruction could result in fire or explosion, which could cause property damage, personal injury, or death.
 - This instruction manual contains important information necessary for the proper assembly and safe use of the appliance.
 - Read and follow all warnings and instructions before assembling and using the appliance.
 - Follow all warnings and instructions when using the appliance.
 - Keep this manual for future reference.

-  **WARNING**
- Do NOT store or use gasoline or other flammable liquids or vapors in the vicinity of this or any other appliance.
 - When cooking with oil/grease, do NOT allow the oil/grease to exceed 350°F (176.5°C). Do NOT store or use extra cooking oil in the vicinity of this or any other appliance.

Important Safeguards

- ⚠ **DANGER:** Failure to follow the dangers, warnings and cautions in this manual may result in serious bodily injury or death, or in a fire or an explosion causing damage to property
- ⚠ **WARNINGS:**
- ⚠ This grill is for outdoor use only, and should NOT be used in a building, garage or any other enclosed area.
- ⚠ Do NOT operate, light or use this appliance within ten feet (3.05 m) of walls, structures or buildings.
- ⚠ For residential use only. This grill is NOT for commercial use.
- ⚠ Never use charcoal that has been pre-treated with lighter fluid. Use only a high grade plain charcoal, charcoal/wood mixture, lump charcoal or cooking wood. The conversion to or attempted use of any other fuel source in this charcoal grill is dangerous and will void your warranty.
- ⚠ This grill is NOT intended for and should never be used as a heater. TOXIC fumes can accumulate and cause asphyxiation.
- ⚠ Do NOT use grill for indoor cooking. TOXIC carbon monoxide fumes can accumulate and cause asphyxiation.
- ⚠ This grill is safety certified for use in the United States and/or Canada only. Do NOT modify for use in any other location. Modification will result in a safety hazard and will void your warranty.
- ⚠ Apartment dwellers: Check with management to learn the requirements and fire codes for using a charcoal grill in your apartment complex. If allowed, use outside on the ground floor with a ten foot (3.05 m) clearance from any structure. Do NOT use on or under balconies.
- ⚠ Minimum clearance from sides and back of unit to combustible construction is 36 inches (91.4 cm). Do NOT use this appliance under any type of overhang or roof.
- ⚠ Do NOT use gasoline, kerosene or alcohol for lighting.
- ⚠ Do NOT use in an explosive atmosphere. Keep grill area clear and free from combustible materials, gasoline and other flammable vapors and liquids.
- ⚠ Do NOT store or use gasoline or other flammable liquids or vapors within 25 feet (7.62 m) of this appliance.
- ⚠ Do NOT block holes in sides or back of grill.
- ⚠ Inspect grill before each use.
- ⚠ Do NOT alter grill in any manner. Any alteration will void your warranty.
- ⚠ Do NOT build this model of grill in any built-in or slide-in construction. Ignoring this warning could cause a fire or an explosion that can damage property and cause serious bodily injury or death.
- ⚠ Do NOT use the grill unless it is COMPLETELY assembled and all parts are securely fastened and tightened.
- ⚠ This grill should be thoroughly cleaned and inspected on a regular basis.
- ⚠ Use only Captivate Brands USA, Inc factory-authorized parts. The use of any part that is not factory-authorized can be dangerous and will void your warranty.
- ⚠ Do NOT operate this appliance without reading "Operating Instructions" in this manual.
- ⚠ To avoid burns, do NOT touch metal parts of grill until they have completely cooled, unless you are wearing protective gear (pot holders, gloves, BBQ mittens, etc.).
- ⚠ Never touch grids (charcoal, cooking or warming), ashes or coals to see if they are hot.
- ⚠ Do NOT use on wooden decks, wooden furniture or other combustible surfaces.
- ⚠ This grill is NOT to be used in or on boats or recreational vehicles.
- ⚠ Position grill so wind cannot carry ashes to combustible surfaces.
- ⚠ Do NOT use in high winds.
- ⚠ Never lean over the grill when lighting.
- ⚠ Do NOT leave a lit grill unattended. Keep children and pets away from grill at all times.
- ⚠ Do NOT attempt to move grill when in use. Allow the grill to cool before moving or storing.
- ⚠ Do NOT leave grill unattended while preheating or burning off food residue.
- ⚠ When cooking, fire extinguishing materials should be readily accessible. In the event of an oil/grease fire, do NOT attempt to extinguish with water. Use type BC dry chemical fire extinguisher or smother with dirt, sand or baking soda.
- ⚠ If grill has not been cleaned, a grease fire can occur that may damage the product.
- ⚠ Do NOT place empty cooking vessels on the appliance while in operation.
- ⚠ Use caution when placing anything on the grill while the appliance is in operation.
- ⚠ Never add lighting fluid to hot or warm coals as a flashback may occur causing serious injury or damage to property.
- ⚠ Always place your grill on a hard, non-combustible level surface. An asphalt or blacktop surface may not be acceptable for this purpose.
- ⚠ Do NOT remove the ashes until they are completely and fully extinguished.
- ⚠ Live hot briquettes and coals can create a fire hazard. Always empty the bottom bowl and grill after each use.
- ⚠ Do NOT place fuel (charcoal briquettes, wood or lump charcoal) directly into bottom of grill. Place fuel only on the charcoal pan/grid.
- ⚠ Do NOT allow charcoal to rest on the walls of grill. Doing so will greatly reduce the life of the metal and finish of your grill.
- ⚠ Check to make sure the air vents are free of debris and ash before using the grill.
- ⚠ Extinguished coals and ashes should be placed a safe distance from all structures and combustible materials.
- ⚠ With a garden hose, completely wet the surface beneath and around grill to extinguish any ashes, coals or embers that may have fallen during the cooking or cleaning process.
- ⚠ The use of alcohol, prescription or non-prescription drugs may impair the consumer's ability to properly assemble and/or safely operate this grill.
- ⚠ Always wear protective gloves when adding fuel (charcoal briquettes, wood or lump charcoal) to retain desired heat level.
- ⚠ Keep all electrical cords away from a hot grill.
- ⚠ Always use a meat thermometer to ensure food is cooked to a safe temperature.
- ⚠ Never cover entire cooking area with aluminum foil. Laying the foil on the grates can restrict the intended air flow inside the grill, create barriers to the proper flow of grease to the catch pan, which sets the stage for lots of it to build up on the bottom tray, which in turn, builds the potential for grease fires and flare ups.
- ⚠ Never turning the grill to high, and letting it run for a while. Use protective gloves when assembling this product.
- ⚠ Do NOT force parts together as this can result in personal injury or damage to the product.
- ⚠ Do NOT touch ash receiver or ash receiver handle until grill has completely cooled, unless you are wearing protective gear.
- ⚠ Do NOT touch air vent or air vent handle until grill has completely cooled, unless you are wearing protective gear.
- ⚠ Death, serious injury or damage to property may occur if the above is not followed exactly.
- ⚠ To protect against electrical hazards do not immerse cord, plugs, or motor in water or other liquids.
- ⚠ Unplug the motor from outlet and remove the batteries when not in use, or before cleaning. Make sure motor is off before placing it on the motor bracket.
- ⚠ Do not operate the rotisserie motor with a damaged cord or plug.
- ⚠ Do not operate the rotisserie motor if it should malfunction.



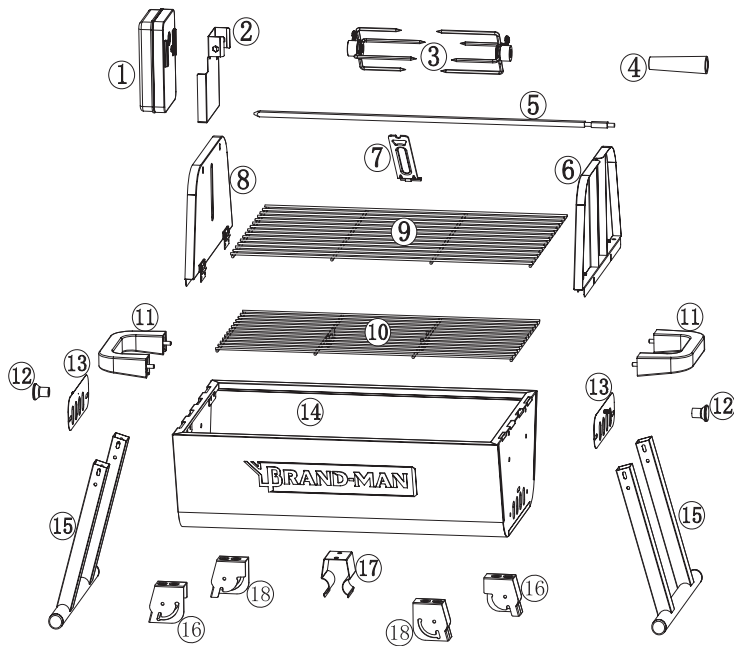





Expanded View

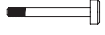

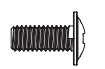
Tool Required (not included):
Philips Head Screwdriver



HARDWARE LIST

No	Description	Qty	
A	M5x45mm Philips Head Step Screw	8	
B	M5x12mm Philips Head Screw	10	
C	M5x9mm Philips Head Step Screw	4	
D	M4x8mm Philips Head screw	8	
E	Ø5.2x Ø12 Spring Washer	10	
F	Ø5.2x Ø12x 0.8 Flat Washer	10	
G	M4x16mm Butterfly Screw	4	
H	M5 Dome Nut	4	
I	M6x18mm Philips Head Step Screw	2	
J	M5 Lock Nut	8	
K	ST4.0x15mm Philips Head Self-Tapping Screw	2	
L	M6 Butterfly nut	4	
M	Ø6.2x Ø16x 0.8 Flat Washer	4	

PART LIST

No	Name	Qty
1	Rotisserie Motor	1
2	Rotisserie Motor Bracket	1
3	Rotisserie Prongs	2
4	Rotisserie Rod Handle	1
5	Rotisserie Rod	1
6	Right Wind Deflector	1
7	Grate Lifter (can be used as wrench)	1
8	Left Wind Deflector	1
9	Cooking Grid	1
10	Charcoal Grid	1
11	Side Handle	2
12	Air Damper Handle	2
13	Air Damper	2
14	Rotisserie Firebox	1
15	Leg	2
16	Leg Support Bracket #1	2
17	Leg Holder	1
18	Leg Support Bracket #2	2

ASSEMBLY

DO NOT RETURN TO PLACE OF PURCHASE.

For assistance, call 1-855-200-8445 toll-free.

For Easiest Assembly:

- 1. Select an area where you will assemble this product. To protect components, choose a smooth surface that's free of cracks or openings.**
- 2. Spread out all parts.**
- 3. Tighten all hardware connections by hand first. Then, before completing each step, go back and fully tighten all hardware. Be careful not to overtighten. That could damage surfaces or strip threads.**
- 4. For best results, complete each step in the order presented.**

To complete assembly you will need:

- One bag of charcoal (not included)

Typical assembly is approximately 30 minutes.

ASSEMBLY INSTRUCTIONS

1

Attach Leg Support Bracket (16) (18) onto the Leg (15)

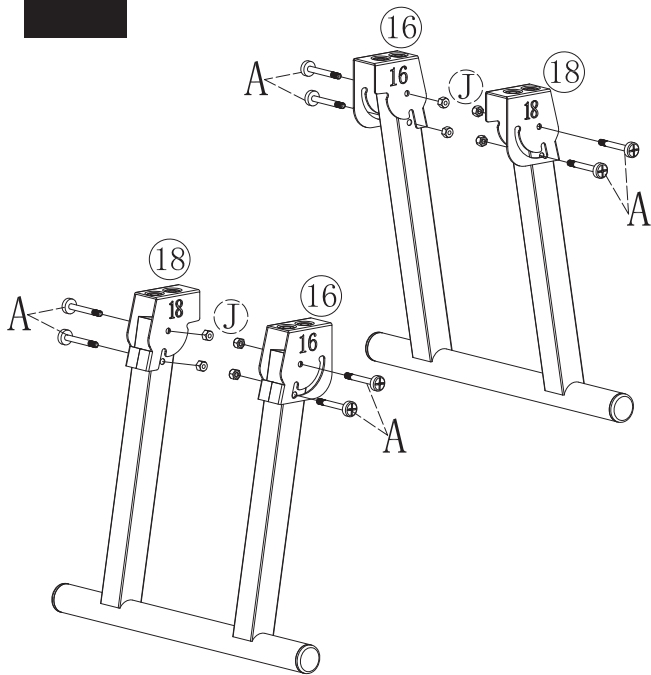

A M5x45mm Step Screw 8PCS
J M5 Lock Nut 8PCS

2

Attach the Legs onto the Rotisserie Firebox (14)

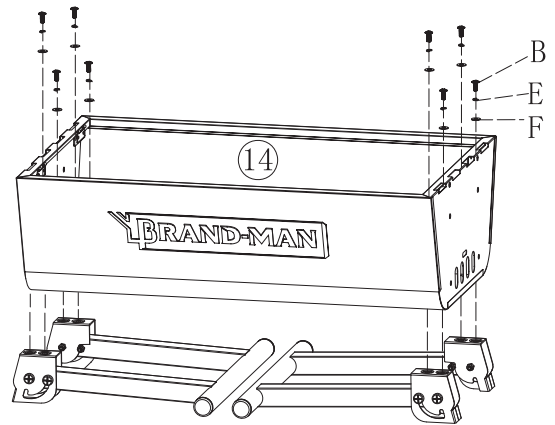

B M5x12mm Screw 8PCS
E Ø5.2x Ø12 Spring Washer 8PCS
F Ø5.2x Ø12x0.8 Flat Washer 8PCS

3

Attach Leg Holder (17)

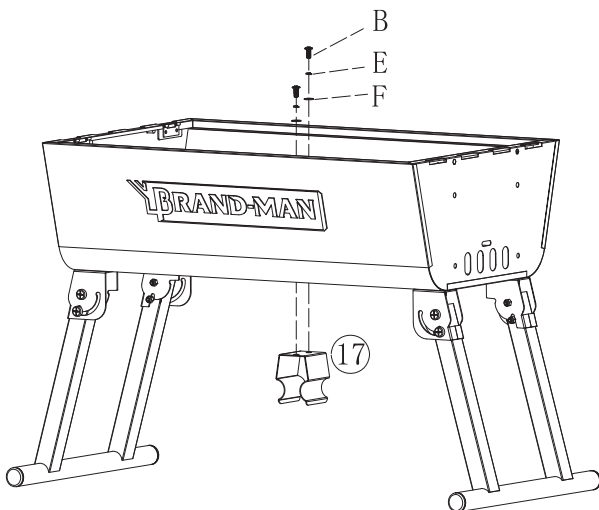

B M5x12mm Screw 2PCS
E Ø5.2x Ø12 Spring Washer 2PCS
F Ø5.2x Ø12x0.8 Flat Washer 2PCS

4

Attach Left Wind Deflector (8)

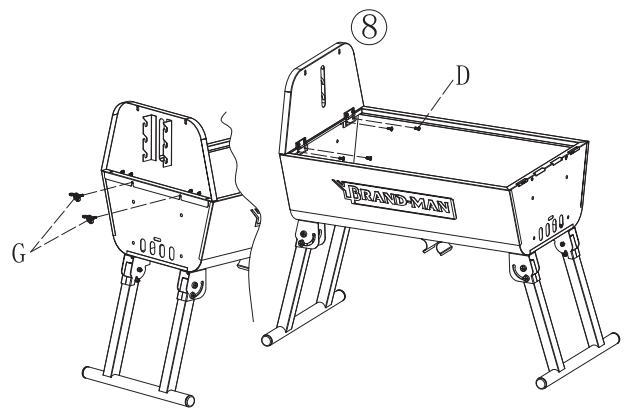

G M4x16mm Butterfly Screw 2PCS
D M4x8mm Screw 4PCS

ASSEMBLY INSTRUCTIONS

5

Attach Right Wind Deflector (6)

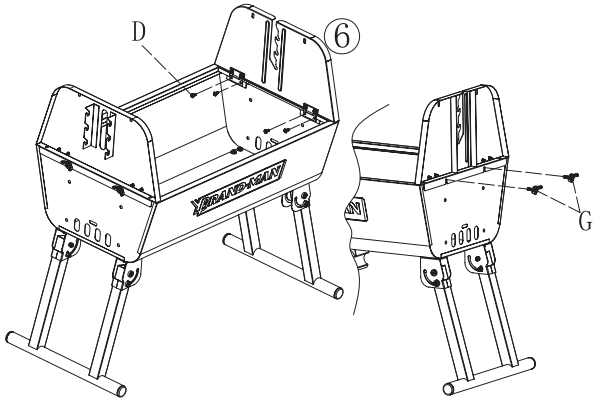

G M4x16mm Butterfly Screw 2PCS
D M4x8mm Screw 4PCS

6

Attach Air Damper (13) and Air Damper Handle (12)

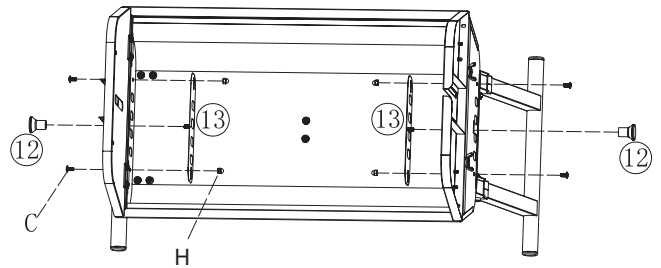

C M5x9mm Philips Head Step Screw 4PCS
H M5 Dome Nut 4PCS

7

Attach Side Handle (11)

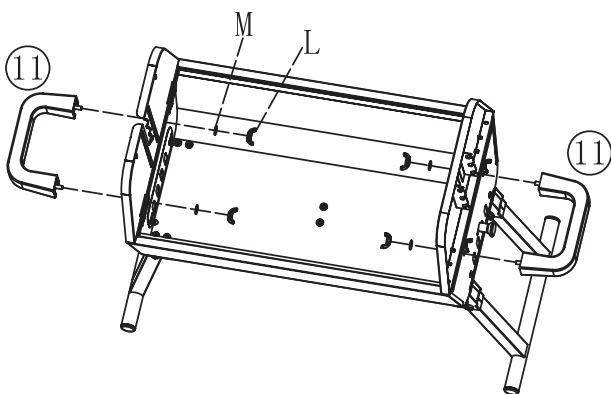

L M6 Butterfly Nut 4PCS
M $\varnothing 6.2 \times \varnothing 16 \times 0.8$ Flat Washer 4 PCS

8

Insert Charcoal Grid (10) and Cooking Grid (9)

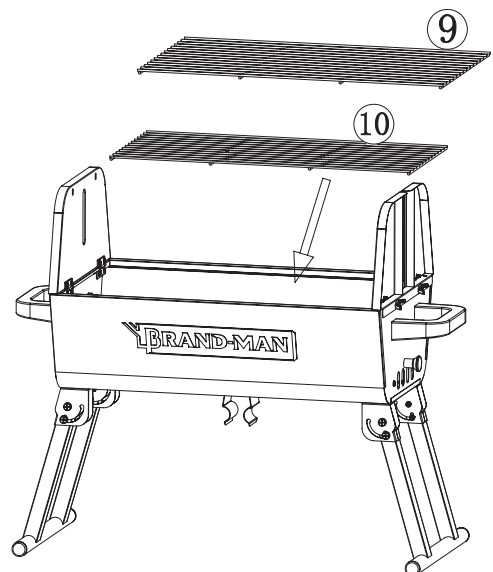

ASSEMBLY INSTRUCTIONS

9

Assemble the rotisserie

(Note: Please read operating rotisserie Instructions on page 8)

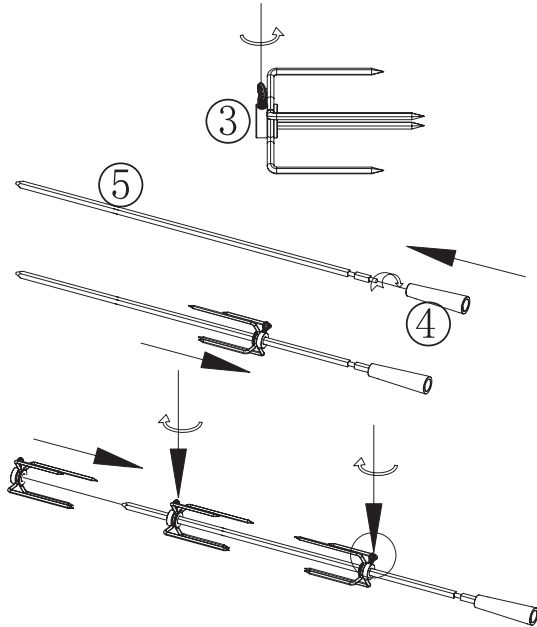

10

Attach the Rotisserie Motor Bracket (2)

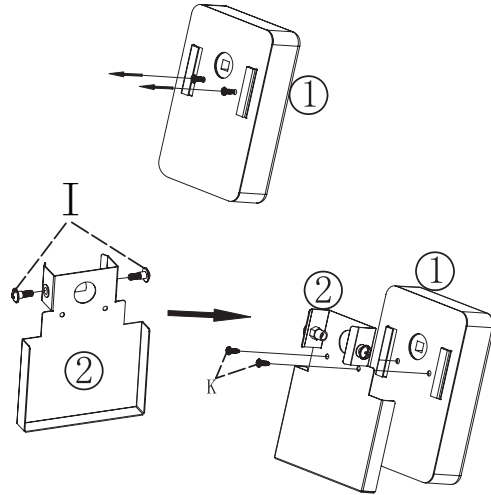

K ST4.0x15mm Self-Stepping Screw 2PCS

I M6x18mm Philips Head Step Screw 2PCS

11

Insert the Rotisserie and Attach the Rotisserie Motor

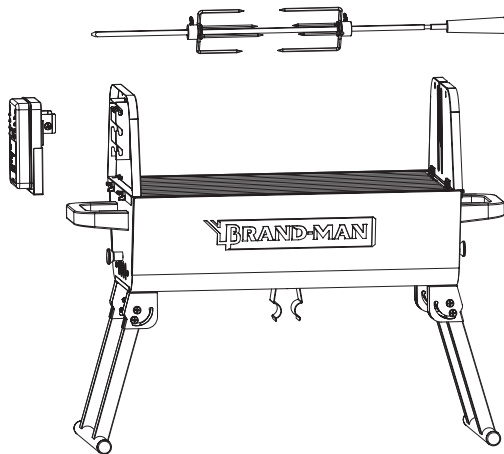

Operate with 2x1.5V D size batteries

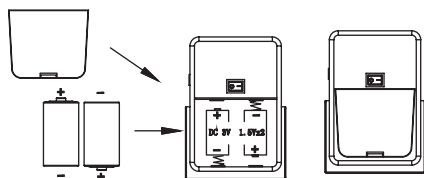

12

Full Assembly

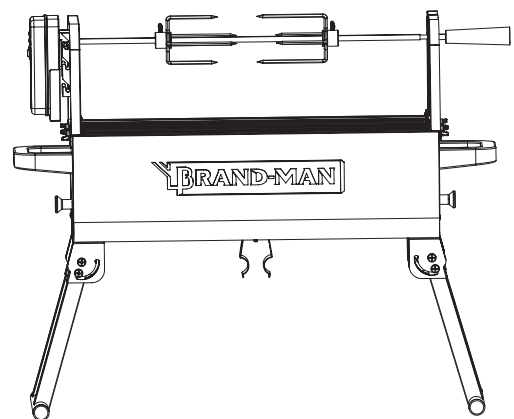

ASSEMBLY INSTRUCTIONS

13

Removable Cooking Grid with Grate Lifter

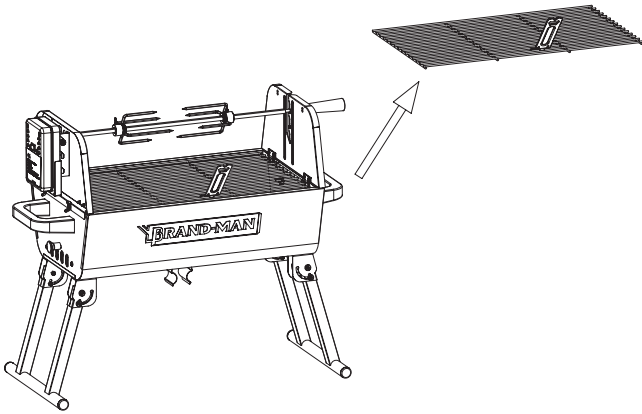

14

Fold in Wind Deflector and Leg

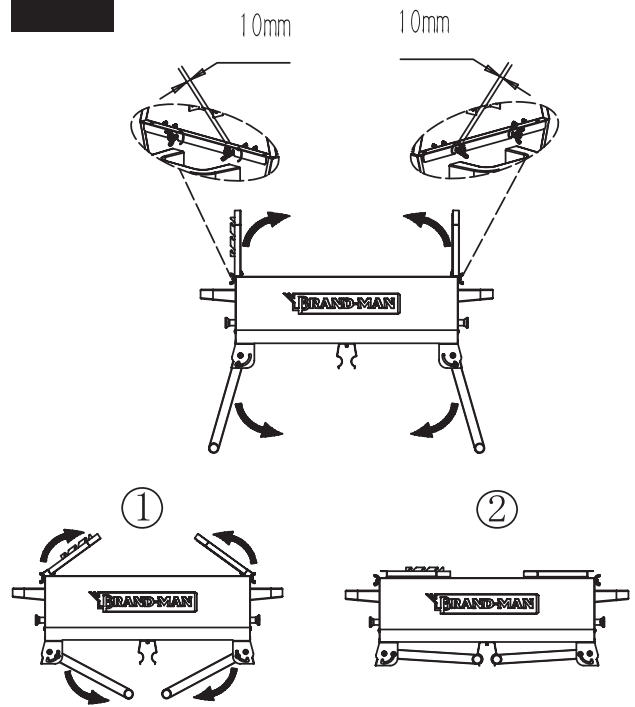

15

Fold out Wind Deflector and Leg

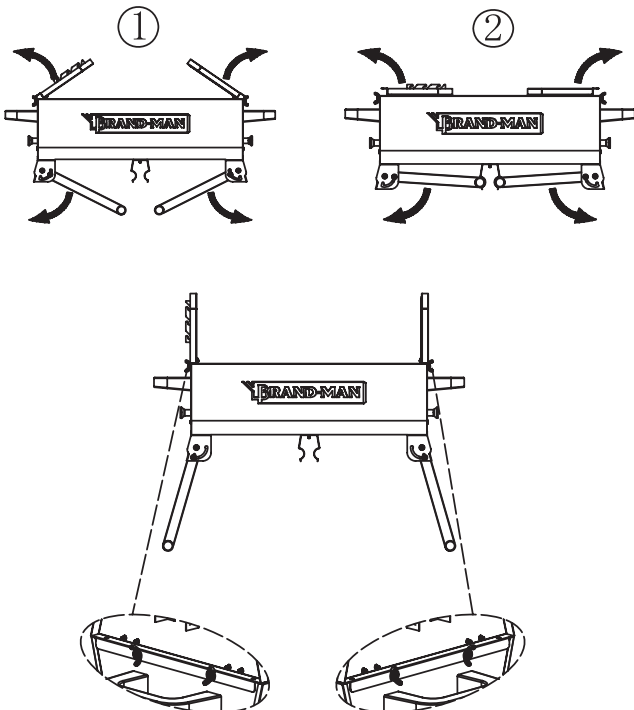

Operating Instructions

- ▲ **CAUTION: Never use charcoal that has been pre-treated with lighter fluid. Use only a high grade plain charcoal, charcoal/wood mixture, lump charcoal or cooking wood.**

First Use

1. Make sure all labels, packaging and protective films have been removed from the grill.
2. Remove manufacturing oils before cooking on this grill for the first time, by operating the grill for at least 15 minutes. This will "heat clean" the internal parts and dissipate odors.

Lighting Instructions

- ▲ **CAUTION: Keep outdoor cooking appliance area clear and free from combustible materials, gasoline and other flammable vapors and liquids.**
 - ▲ **CAUTION: Check to make sure the air vents are free of debris and ash before using the grill.**
 - ▲ **CAUTION: When using a liquid starter, always check bottom bowl and ash receiver before lighting. Fluid can collect in the bottom bowl and/or ash receiver and could ignite, resulting in a fire.**
 - ▲ **CAUTION: Never add lighting fluid to hot or warm coals as flashback may occur, causing serious injury or damage to property.**
1. Remove cooking grid.
 2. Arrange charcoal briquettes or other fuel on the charcoal grid.
 3. Light per instructions on fuel package.
 4. Allow fuel to become glowing coals before cooking.

Operating Instructions

Operating The Rotisserie

1. Install the rotisserie motor onto the motor mount bracket, ensure that the rotisserie motor is turned to "OFF"

Note: Rotisserie motor is capable of turning up to a 22 lb. cut of meat or poultry.

2. Place one fork onto the spit rod with the prongs facing away from the handle.

Do not tighten set screw at this time.

3. Skewer meat with the spit rod and slide to the center of the rod.

Warning: Make sure the weight of meat or poultry is less than 22lb.

4. Place second fork onto the spit rod with the prongs facing the meat.

5. Slide both forks tightly against the meat and securely tighten the fork set screws.

6. Check the balance of the food on the rod by rotating the loaded spit rod loosely in your hands. The rod should rotate evenly with little effort. Adjust the food on the spit to achieve a balanced assembly.

7. Place the loaded spit rod into the motor assembly and support bracket.

8. Turn the rotisserie motor "ON."

WARNING: Always use oven mitts/gloves to protect your hands. Metal parts become hot during use. Use extreme caution when handling spit rod and forks.

9. Turn the rotisserie motor to "OFF" when the food is done.

10. When food is done, use oven mitts/gloves to remove spit rod from motor assembly.

11. Loosen fork set screws and remove meat by sliding off the end of the spit rod.

Direct Cooking

Cooking directly over hot coals is ideal for searing in juices and grilling food requiring less than 25 minutes of grilling time such as steaks, hamburgers, hot dogs, chicken parts, vegetables and fruit.

1. Remove cooking grid.
2. Load and light charcoal per "Lighting" section.
3. While wearing protective gloves, carefully spread hot coals evenly across charcoal grid with a long-handled tool.
(Please refer to the picture 'Direct-Cooking' for how to set the coals)
4. While wearing protective gloves, replace cooking grid and allow grill to preheat.
5. While wearing protective gloves, and place food onto cooking grids above the hot coals with long handle tongs.
6. Cook until desired internal food temperatures are achieved.

Note: If additional briquettes are needed, remove food from cooking grid and, while wearing protective gloves, remove the cooking grid and place additional briquettes without disturbing the hot coals. Carefully replace cooking grid and food.

7. Allow charcoal to burn out by closing all vents. Except in the case of an emergency, do NOT pour water on hot coals

Direct Cooking

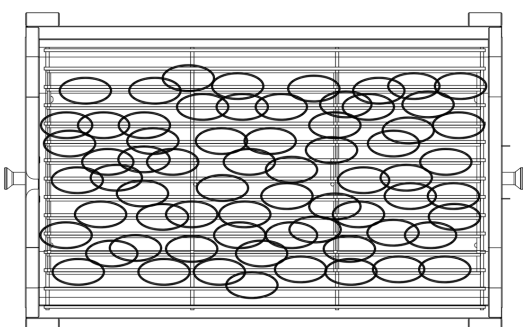

Indirect Cooking

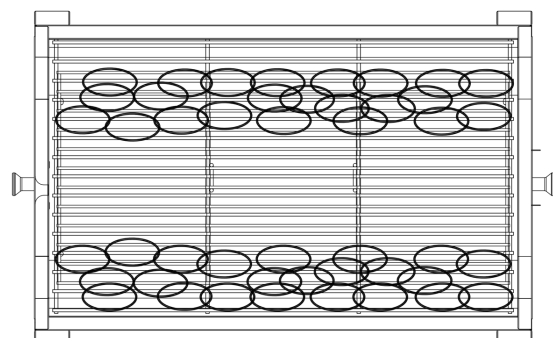

Operating Instructions

Indirect Cooking

Not cooking directly over hot coals is ideal for slow cooking and grilling foods requiring more than 25 minutes, such as most roasts, loins, chops, whole chickens, turkey, fish and baked goods.

1. Remove cooking grid.
2. Load and light charcoal per “Lighting” section.
3. While wearing protective gloves, carefully spread hot coals to the outsides of charcoal grid with a long-handle tool. (Please refer to the picture ‘Indirect-Cooking’ for how to set the coals.)
4. While wearing protective gloves, replace cooking grid, and allow grill to preheat.
5. Use long-handled tools to place food onto cooking grids above the areas without hot coals.
6. Cook until desired internal food temperatures are achieved.

Note: If additional briquettes are needed, remove food from cooking grid and, while wearing protective gloves, remove the cooking grid and place additional briquettes without disturbing the hot coals. Carefully replace cooking grid and food.

7. Allow charcoal to burn out by closing all vents. Except in the case of an emergency, do NOT pour water on hot coals.

Turning Off

1. Allow charcoal to completely extinguish itself.

⚠ WARNING: Do NOT use water to extinguish. This can be dangerous and cause damage.

2. Dispose of the ashes in a proper location.

Controlling Flare-ups:

⚠ CAUTION: Do NOT use water on a grease fire. This can cause the grease to splatter and could result in serious burns, bodily harm or other damage.

⚠ CAUTION: Do NOT leave grill unattended while preheating or burning off food residue. If grill has not been cleaned, a grease fire can occur that may damage the product.

⚠ WARNING: When cooking, fire extinguishing materials should be readily accessible. In the event of an oil/grease fire, use a type BC dry chemical fire extinguisher or smother with dirt, sand or baking soda. DO NOT attempt to extinguish with water.

Flare-ups are a part of cooking meats on a grill and add to the unique flavor of grilling.

Excessive flare-ups can over-cook your food and be dangerous.

Important: Excessive flare-ups result from the build-up of grease in the bottom of your grill.

If a grease fire occurs, wait until the grease burns out.

If excessive flare-ups occur, do **NOT** pour water onto the flames.

Operating Instructions

Minimize Flare-ups:

1. Trim excess fat from meats prior to cooking.
2. Cook high fat content meats indirectly.
3. Ensure that your grill is on a hard, level, non-combustible surface.
4. Separate charcoal to reduce grease line fire, especially when using the rotisserie.

Cleaning and Care

CAUTION:

1. **Turn motor "OFF" before removing batteries .**
2. **Remove the batteries when not in use and before cleaning.**
3. **To prevent electrical shock hazard, DO NOT immerse the motor or cord in water.**
4. **All cleaning and maintenance should be done when grill is cool and with the ashes properly disposed of.**
5. **Do NOT clean any grill part in a self-cleaning oven. The extreme heat will damage the finish.**

Notices

1. This grill should be thoroughly cleaned and inspected on a regular basis.
2. Abrasive cleaners will damage this product.
3. Never use oven cleaner to clean any part of grill.

Before Each Use

1. Keep the grill area free and clear from any combustible materials, gasoline, and other flammable vapors and liquids.
2. See below for proper cleaning instructions.

Cleaning Surfaces

1. Wait for grill to fully cool.
2. Wipe surfaces clean with a mild dishwashing detergent or baking soda mixed with water.
3. For stubborn stains, use a citrus-based degreaser and a nylon scrubbing brush.
4. Rinse clean with water.
5. Allow to air dry.

Before Storing

1. Wait for grill to fully cool.
2. Clean all surfaces.
3. If storing the grill indoors, cover the grill and store in a cool dry place.
4. If storing the grill outdoors, cover the grill with a grill cover for protection from the weather.

WARRANTY

Captivate Brands USA, Inc warrants to the original retail purchaser of this product, and to no other person, that if this product is assembled, maintained, and operated in accordance with the printed instructions accompanying it, then for a period of two (2) year from the date of purchase, the product's components shall be free from defects in material and workmanship, except for the cooking surface which is not covered by the Limited Warranty. Captivate Brands USA, Inc may require reasonable proof of your date of purchase. Therefore, you should retain your sales slip or invoice. This Limited Warranty shall be limited to the repair or replacement of parts, which prove defective under normal use and service and which Captivate Brands USA, Inc shall determine in its reasonable discretion upon examination to be defective. Before returning any parts, you should contact Captivate Brands USA, Inc's Customer Care Department using the contact information listed below. If Captivate Brands USA, Inc confirms, after examination, a defect covered by this Limited Warranty in any returned part, and if Captivate Brands USA, Inc approves the claim, Captivate Brands USA, Inc will replace such defective part without charge. If you return defective parts, transportation charges must be prepaid by you. Captivate Brands USA, Inc will return replacement parts to the original retail purchaser, freight or postage prepaid.

This Limited Warranty does not cover any failures or operating difficulties due to accident, abuse, misuse, alteration, misapplication, improper installation or improper maintenance or service by you or any third party, or failure to perform normal and routine maintenance on the product as set out in this owner's manual. In addition, the Limited Warranty does not cover damage to the finish, such as scratches, dents, discoloration, rust or other weather damage, after purchase.

This Limited Warranty is in lieu of all other express warranties. Captivate Brands USA, Inc disclaims all warranties for products that are purchased from sellers other than authorized retailers or distributors, including the warranty of merchantability or the warranty of fitness for a particular purpose. CAPTIVATE BRANDS USA INC ALSO DISCLAIMS ANY AND ALL IMPLIED WARRANTIES, INCLUDING WITHOUT LIMITATION THE IMPLIED WARRANTIES OF MERCHANTABILITY AND FITNESS FOR A PARTICULAR PURPOSE. CAPTIVATE BRANDS USA INC SHALL HAVE NO LIABILITY TO PURCHASER OR ANY THIRD PARTY FOR ANY SPECIAL, INDIRECT, PUNITIVE, INCIDENTAL, OR CONSEQUENTIAL DAMAGES.

Captivate Brands USA, Inc further disclaims any implied or express warranty of, and assumes no responsibility for, defects in workmanship caused by third parties.

This Limited Warranty gives the purchaser specific legal rights; a purchaser may have other rights depending upon where he or she lives. Some jurisdictions do not allow the exclusion or limitation of special, incidental or consequential damages, or limitations on how long a warranty lasts, so the above exclusion and limitations may not apply to everyone.

Captivate Brands USA, Inc does not authorize any person or company to assume for it any other obligation or liability in connection with the sale, installation, use, removal, return, or replacement of its equipment, and no such representations are binding on Captivate Brands USA, Inc.

Customer Service

If you have any questions or if you need replacement parts, please contact our customer service:

1-855-200-8445 x102

service@brandmangrill.com

Our customer service staff can be reached 8:00am - 4:30pm Pacific Time, Monday to Friday.