

ASSEMBLY INSTRUCTION

ITEM: N715P394004

Important note:

1. Place all wooden parts on a clean and smooth surface such as a rug or carpet to avoid scratching the parts.
2. Kindly follow the assembly instructions step by step.
3. Do not tighten all screws and bolts until the table is fully assembled.
4. Unscrew the protective plastique supports from the metal insert of the legs before assembly.

PARTS IDENTIFICATION

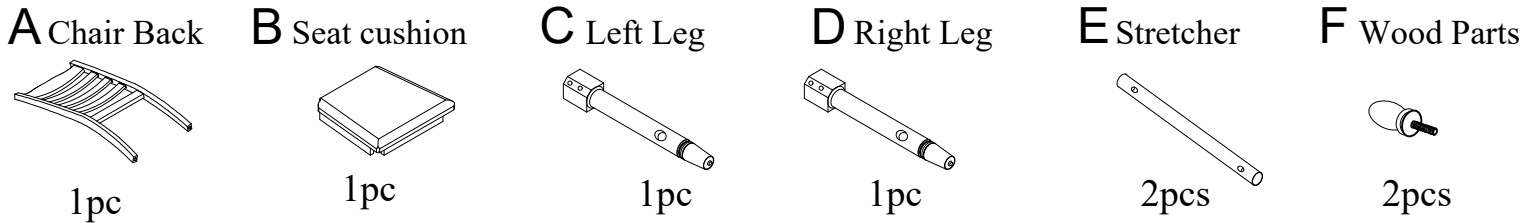

HARDWARE IDENTIFICATION

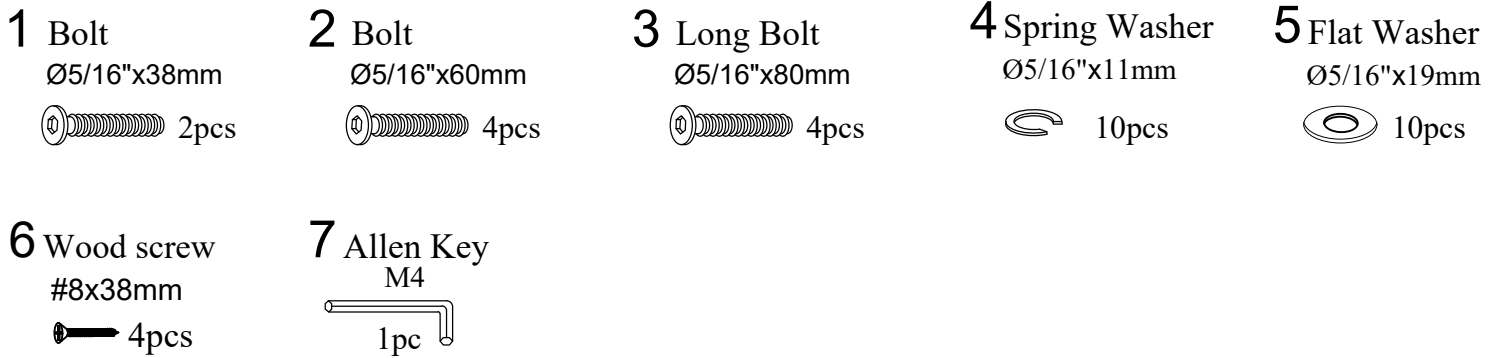

STEP 1

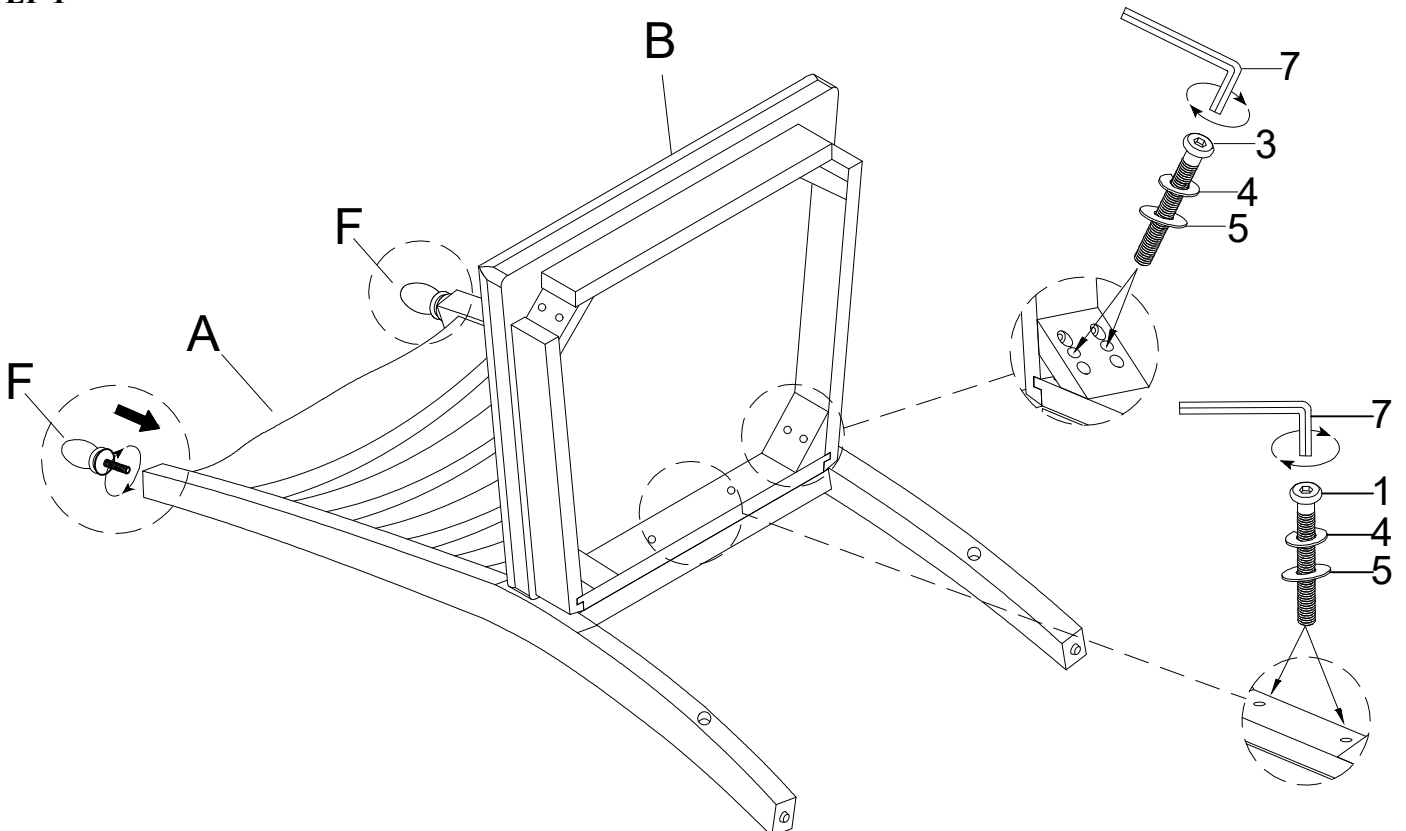

ASSEMBLY INSTRUCTION

ITEM: N715P394004

STEP 2

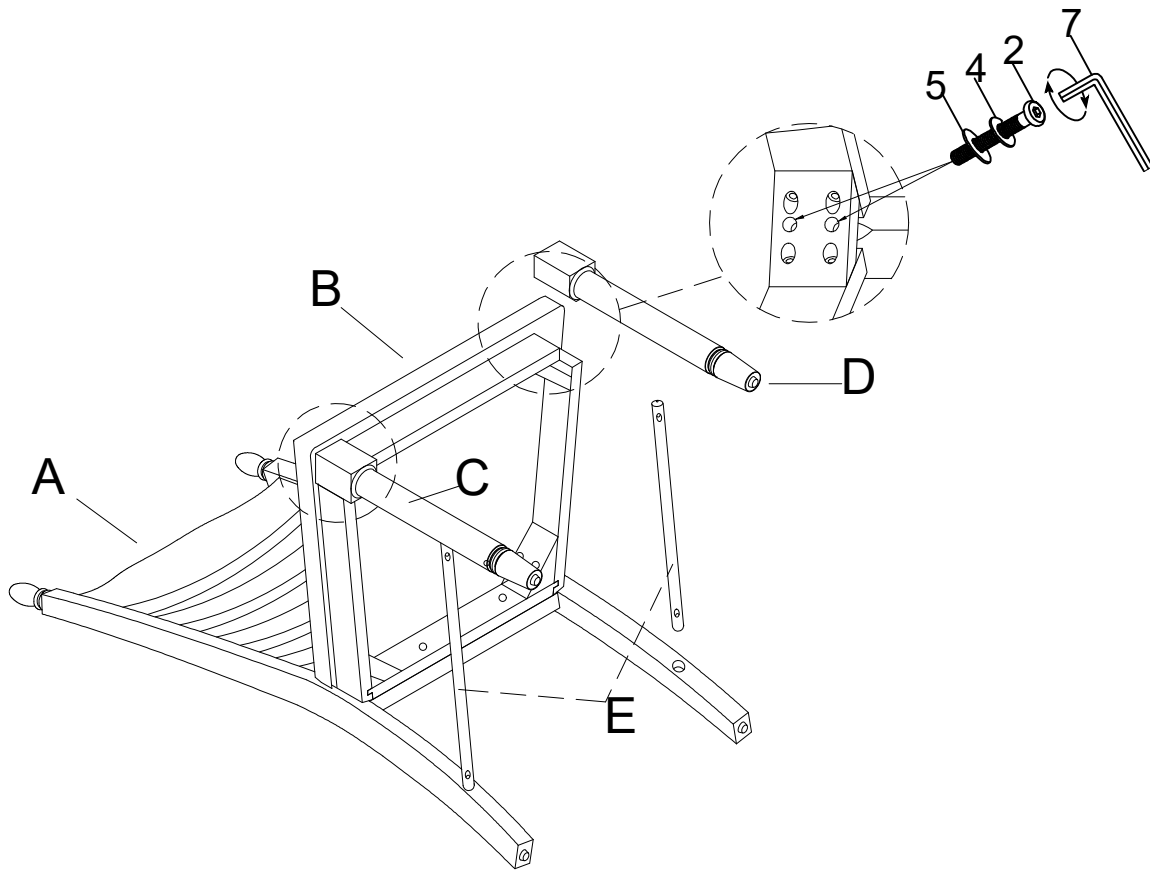

STEP 3

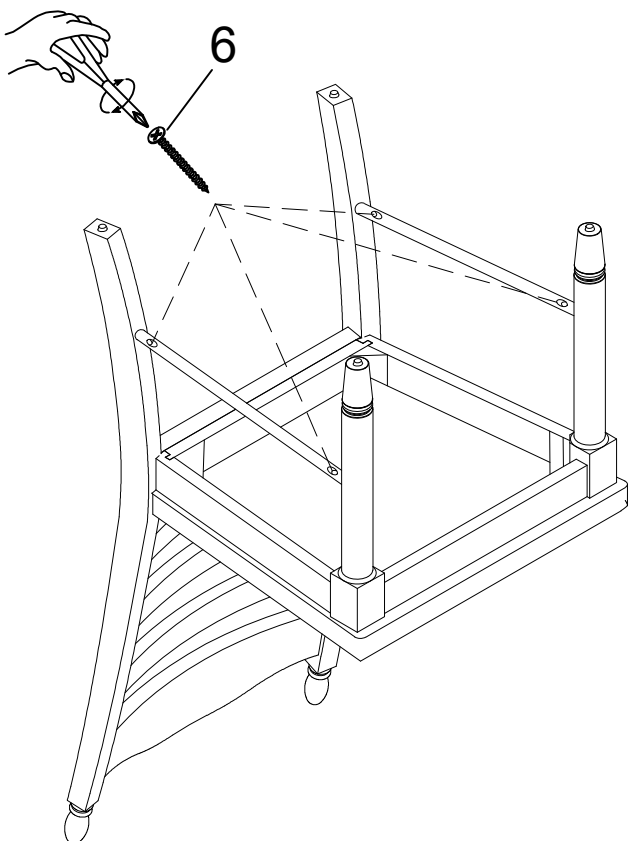

COMPLETE

