

ASSEMBLY INSTRUCTIONS

ROUND DINING TABLE









Please read instructions carefully

Remove all wrapping materials, staples and packing straps from the carton. Refer to Parts List and Hardware List and ensure they are complete before you start assembling. Place all wooden parts on a clean, flat and soft surface (e.g carpet or rug) to prevent parts from being scratched.

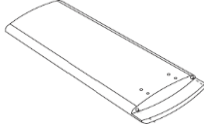
CAUTIONS: 1) DO NOT FULLY TIGHTEN BOLTS AND NUTS UNTIL ALL PARTS HAVE BEEN ASSEMBLED.

2) DO NOT OVER-TIGHTEN BOLTS AND NUTS .

3) KEEP ALL HARDWARE PARTS OUT OF REACH OF CHILDREN.

Carton	Designation	Part	Qty	Part List	HARDWARE	Qty	Hardware List
	TABLE TOP	P1	1pc		H1	16pcs	 M6x40mm JCBC SCREW
	TABLE LEG	P2	4pcs		H2	16pcs	 SPRING WASHER
					H3	16pcs	 FLAT WASHER
					H4	8pcs	 WOOD DOWEL M8X30mm
					H5	8pcs	 LEG GLIDE
					H6	1pc	 ALLEN KEY

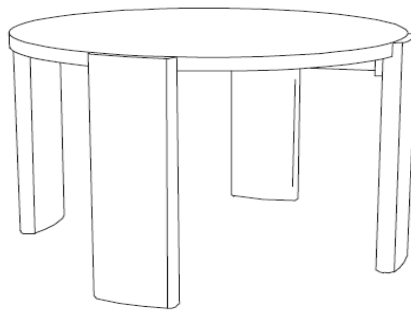

COMPLETE ASSEMBLY

ASSEMBLY INSTRUCTIONS

ROUND DINING TABLE

Prepare the Table Top (P1) by placing it upside-down on a flat, soft & clean surface.

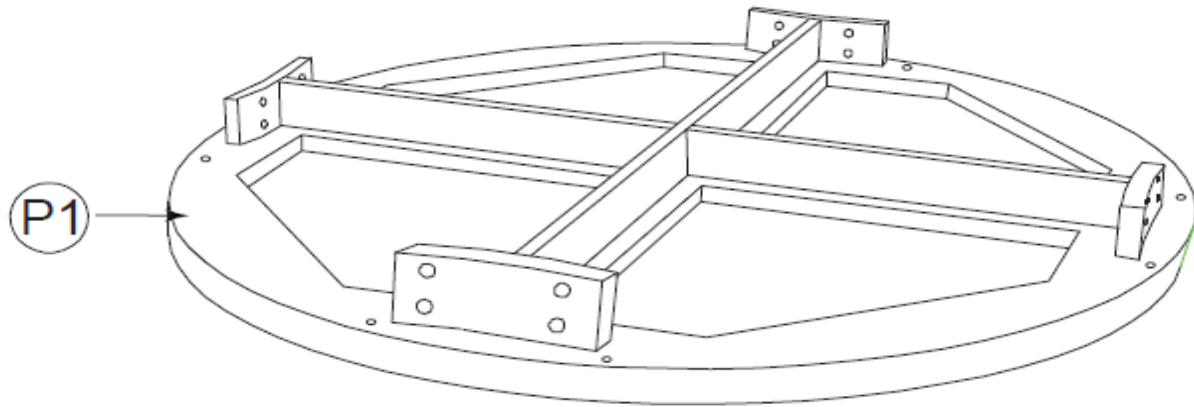

STEP 1

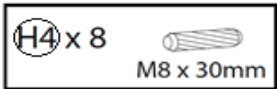

Get all the table legs (P2) and insert the Wooden dowel (H4) into the designated holes at the Legs, until the dowels snug in each hole.

Repeat this step in all legs .

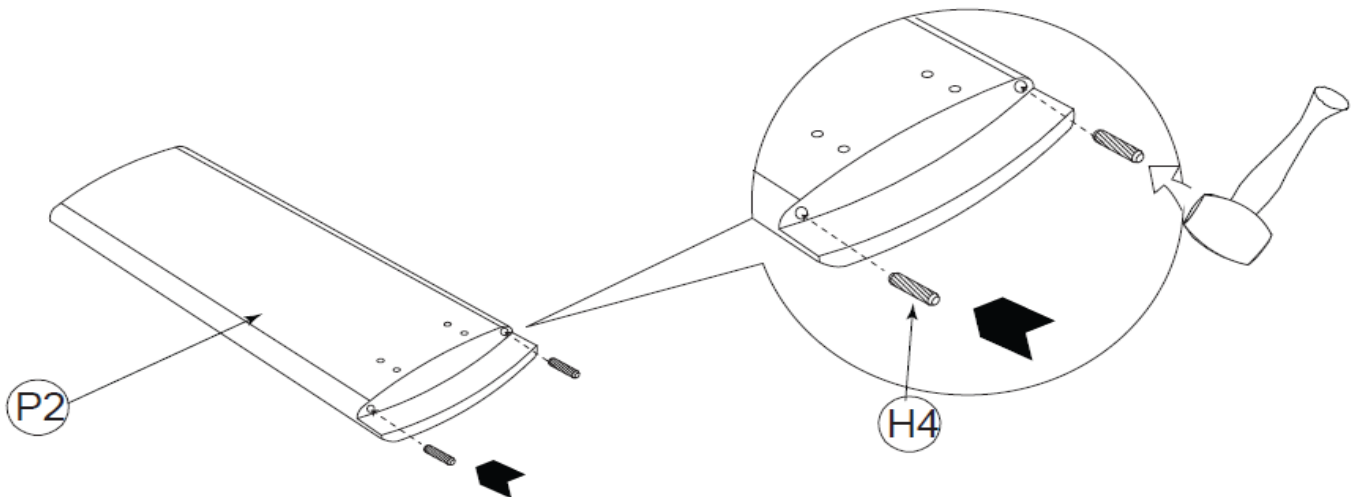

STEP 2

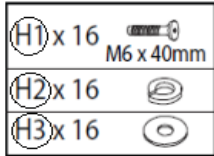

Assemble each table leg (P2) by attaching it to the connecting blocks in the Table Top. You first need to locate the wooden dowels from the table leg and then snug them into the table top holes to connect the leg to the table.

Align Bolt (H1) fitted with a Spring Washer (H2) & a Flat Washer (H3) through the Connecting Block holes. See image below.

Tighten all the bolts with Allen Key (H6).

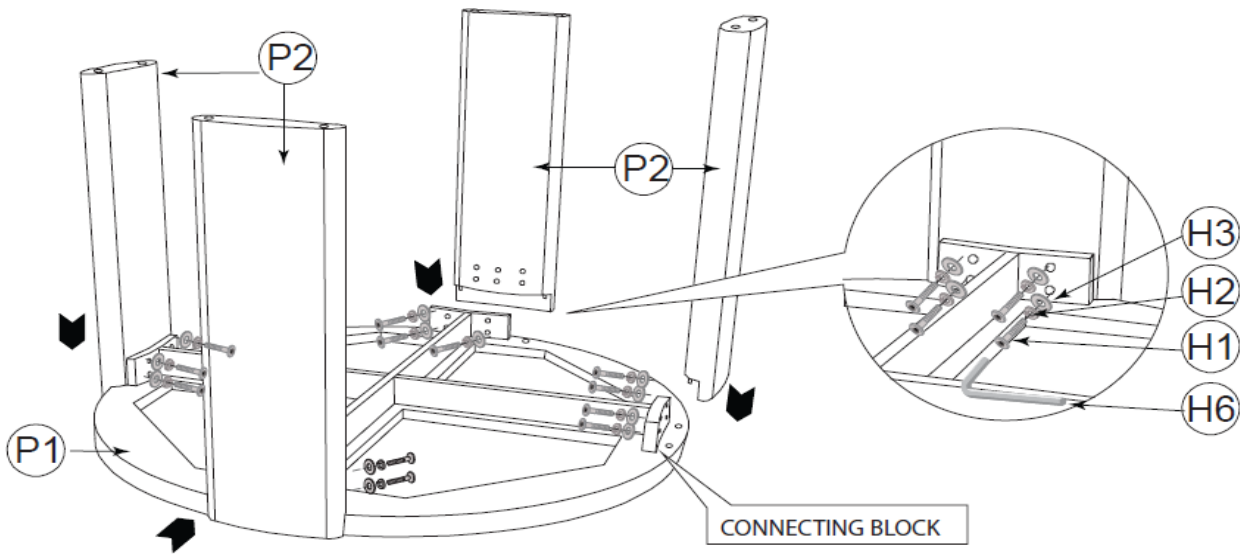

STEP 3



Align 2 Leg Glides (H5) into the table leg insert.

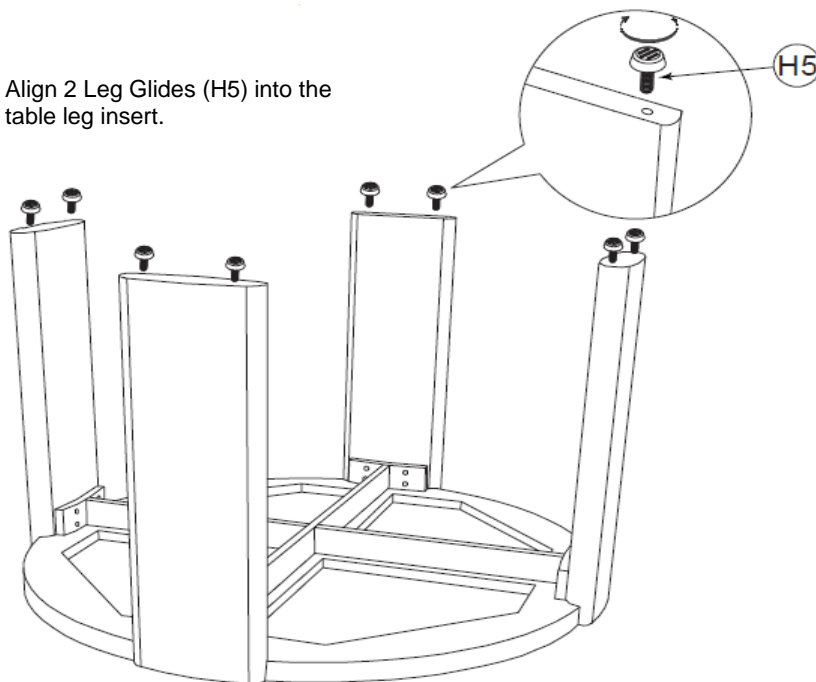

Carefully reposition the Table Upright with the help of Two or more adults.

CARE AND MAINTENANCE

- SAFETY** - To avoid any risk of suffocation to children or animals, dispose off the plastic bags immediately.
- CLEANING** - Clean with damp cloth and mild detergent. Do not use bleach or abrasive products.
- FITTINGS** - Tighten bolts and nuts from time to time to ensure all parts of product are securely fitted.