

Assembly Instructions

Caution : You must read this before you proceed

Please look on top of the product for hardware packs.

COFFEE TABLE

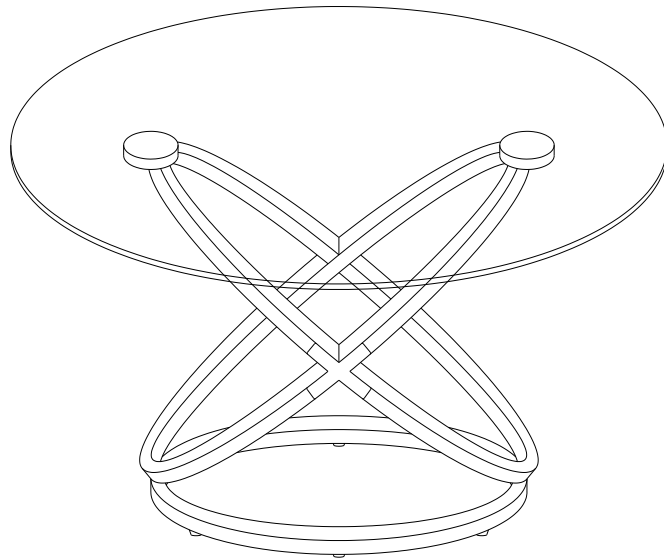

Parts List

Label	Picture	Description	QTY
A	A line drawing of a glass top, which is an oval shape with two small circular holes positioned near the center.	Glass Top	1
B	A line drawing of a cross-foot base. It shows four curved legs that intersect in the center, connected to a circular ring at the bottom. Small feet or gliders are visible at the base of each leg.	Cross Foot	1

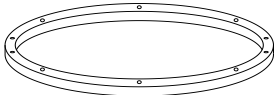
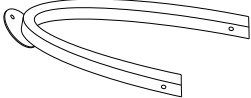
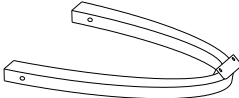
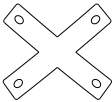
C		Base	1
D		Upper Cross Foot	1
E		Lower Cross Foot	1
F		Cross Iron	2

Hardware

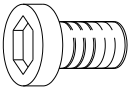
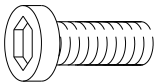
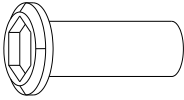
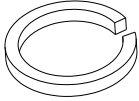
Label	Picture	Description	QTY
①		Bolt (1/4")M6X15mm	13
②		Bolt (1/4")M6X30mm	5
③		Bolt Cap (1/4")M6X15mm	9
④		Spring Washer Rings (Φ6.5mm)	9

⑤		Flat Washer Rings (Φ16mm)	9
⑥		Allen Key	2
⑦		Adjustable Glider Feet (1/4")	7

Assembly Preparation

Before
Beginning
Assembly
:

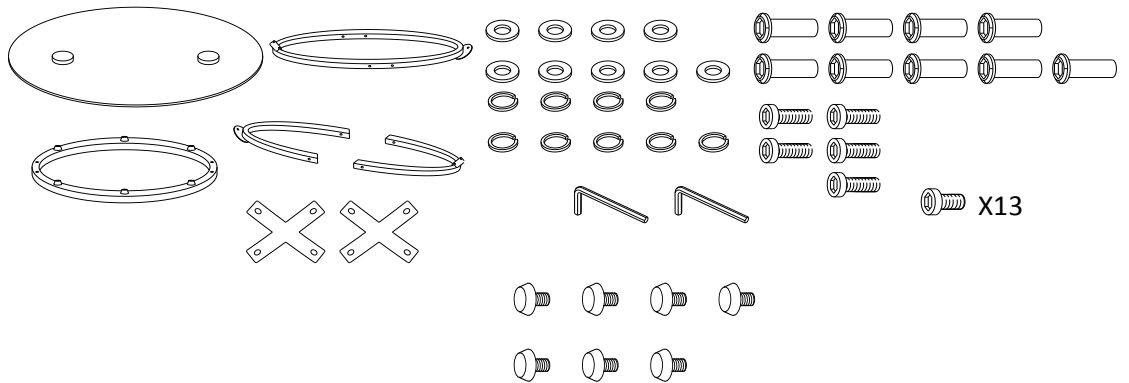

- Read instructions, cover to cover-



- Have 2 adults on hand for assembly-



- Do not assemble on flooring or carpet-



- Assemble on a clean non-marring surface (packing foam)-



- Save all packaging until finished-

Assembly Steps

Overview

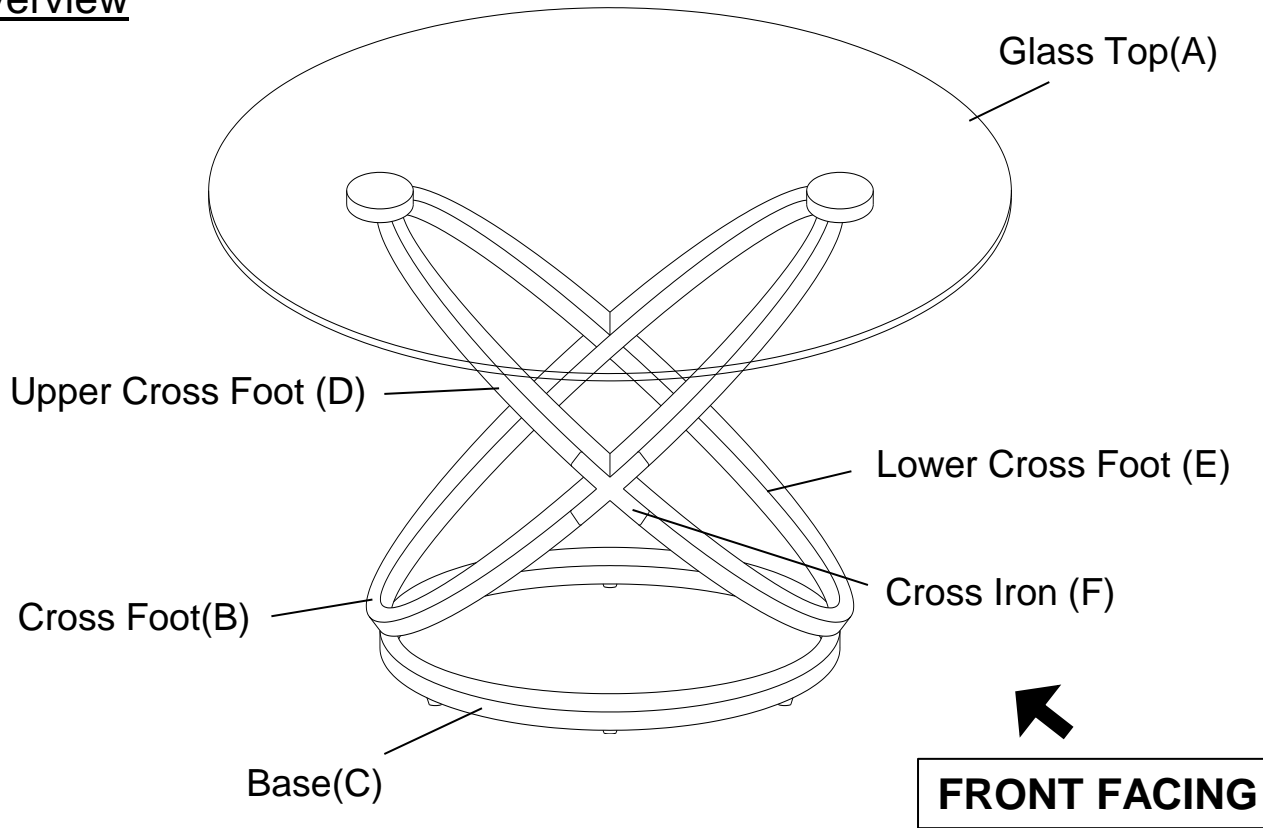

This COFFEE TABLE has multiple parts and may require up to some 30 minutes to assemble. To give you an overview of the COFFEE TABLE parts, the above picture is to help you put the various parts into perspective. Please read through the instructions below to familiarise yourself with the parts and steps before assembly.

Step 1

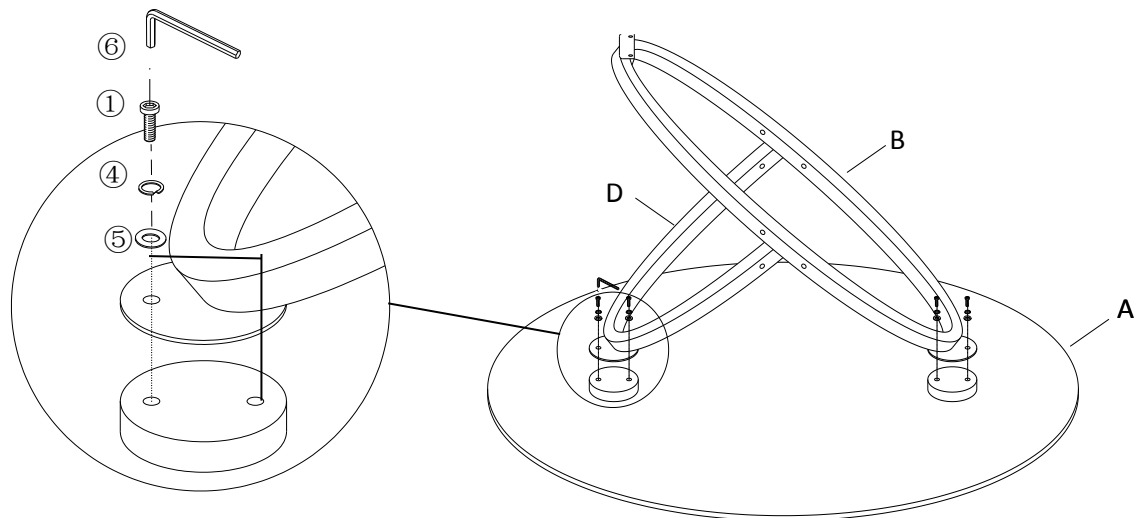

Take out the Glass Top (A). Turn the Coffee Table upside down and place it on a flat surface as shown.

Connect the Glass Top(A) to the Cross Foot(B) & Upper Cross Foot (D) using Bolts(①), Spring Washer Rings(④), Flat Washer Rings (⑤)and the Allen Key(⑥).

DO NOT FULLY TIGHTEN BOLTS.

Step 2

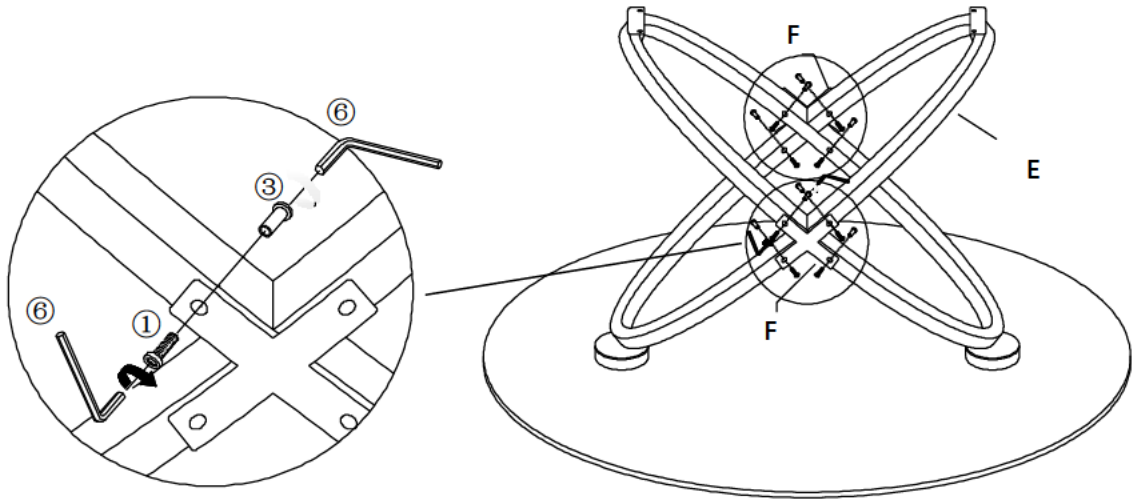

Take out the Lower Cross Foot (E) and affix it to the Upper Cross Foot (D) and the Cross Foot(B) with Cross Irons(F) using Bolts(①), Bolt Caps(③), and the Allen Key(⑥).

DO NOT FULLY TIGHTEN THE BOLTS.

Step 3

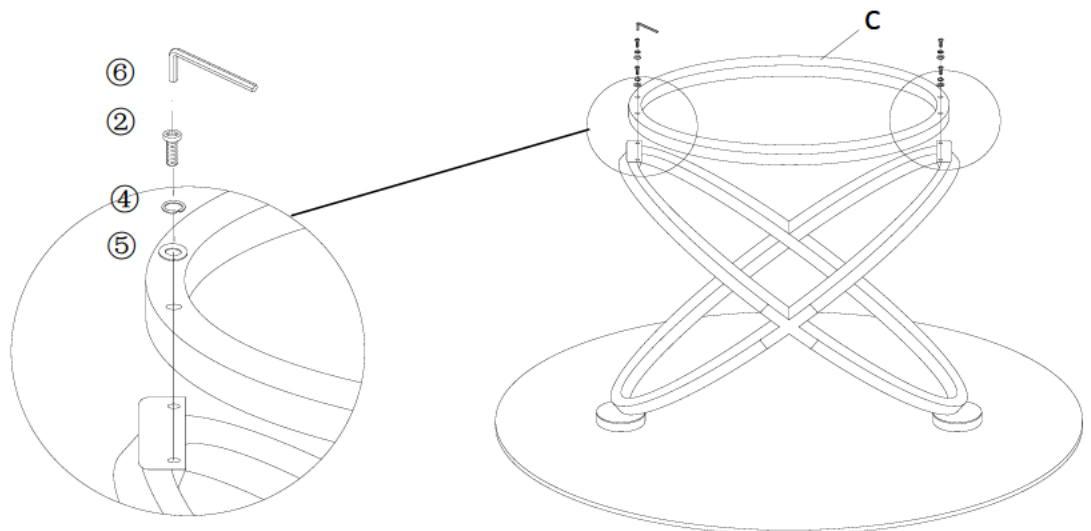

Take out the Base(C) and affix it to the Cross Foot(B) & Upper Cross Foot (D) using Bolts(②), Spring Washer Rings(④), Flat Washer Rings (⑤) and the Allen Key(⑥).
DO NOT FULLY TIGHTEN BOLTS.

Step 4

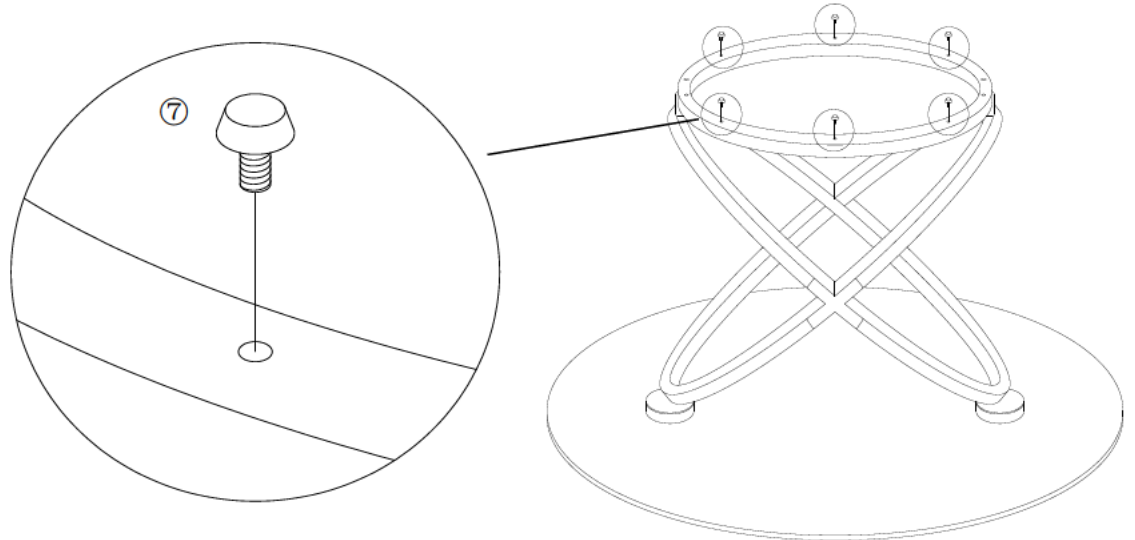

Insert and screw the Adjustable Glider Feet (⑦) onto the base(C) as shown.
Then, Adjust the Adjustable Glider Feet (⑦) so they are all even, and ensure they are secure.
This keeps the coffee table locked in place.

Step 5

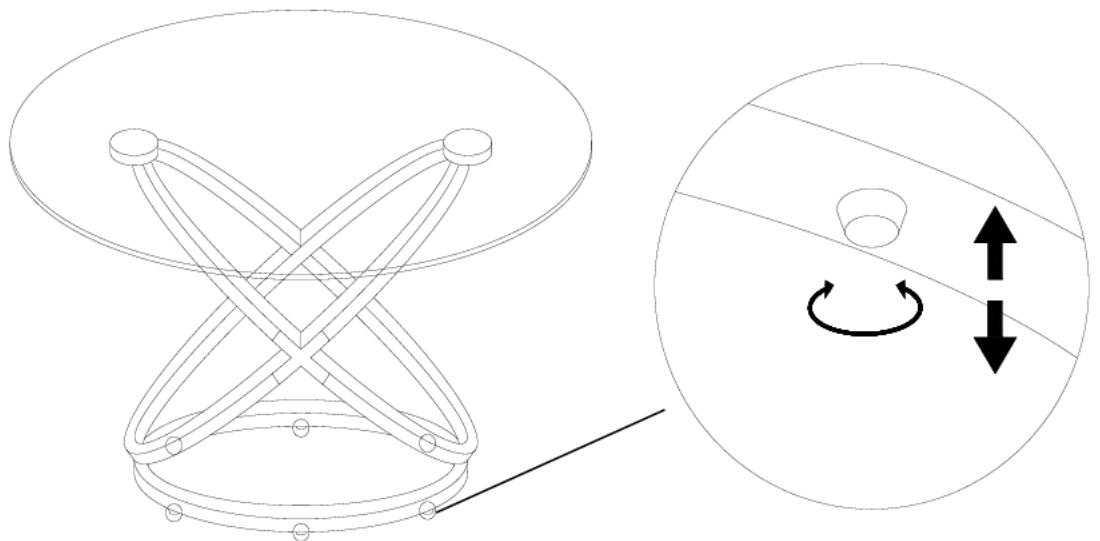

Turn the Coffee table right side up.

Place the Coffee table on a LEVEL SURFACE.

Inspect it and make sure all parts are adequately connected, then proceed to tighten all the bolts.

Caution 1: When tightening these Bolts, tighten sequentially.

DO NOT tighten any Bolt fully and then move towards the next one.

If the table wobbles after tightening, loosen the bolts and Adjustable Glider Feet and execute this same process.

WARNING!! IF THE COFFEE TABLE IS NOT STABLE , IT COULD LEAD TO DAMAGE OF THE PRODUCT.

Ensure all Bolts are fully locked into position.

The Coffee table is ready to be used.

Caution 2: This Coffee table can only be used on a flat, level surface.

Care & Maintenance



- Furniture may scratch floors. We recommend using furniture pads to protect your floors.



- Do not put hot items directly on furniture surface.



- Do not clean furniture with harsh cleansers or polish.



- Do not place furniture under direct sunlight.



- Do not place furniture near heating or cooling vents.



- Do not write on furniture without a padded barrier to protect the surface.



- Do not place furniture outside . For indoor use only.



- Not for commercial use. For residential use only.



- Stains may be removed with mild soap solution and damp cloth.



- Children should not climb or jump on the furniture.



- Dust and pick-up spills using a clean, non-colored, lint-free cloth.