

Installation & Assembly

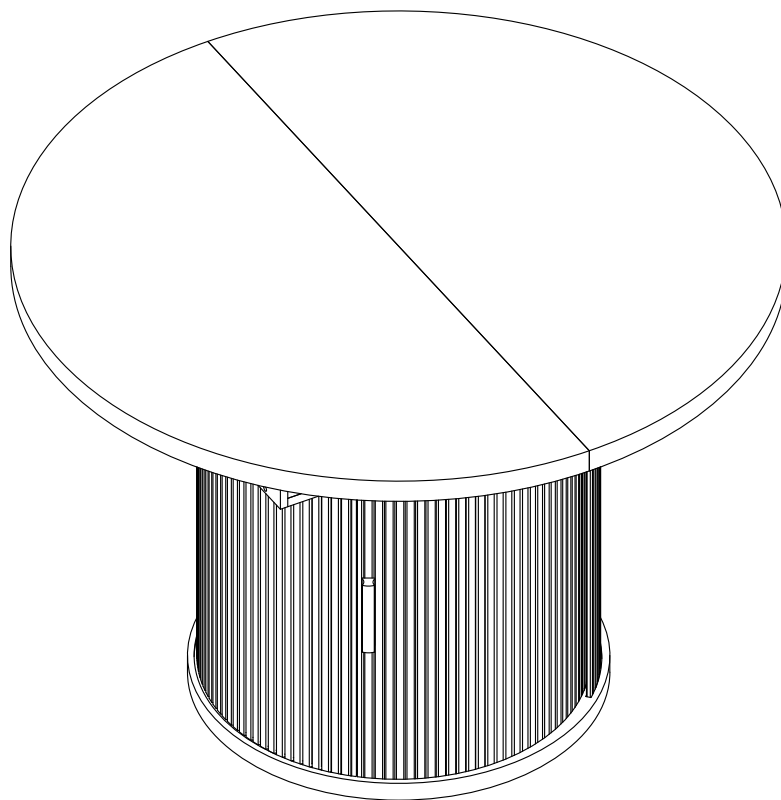

Before You Start

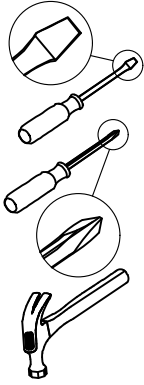

- ✓ Read through each step carefully and follow the proper order
- ✓ Separate and count all your parts and hardware
- ✓ Give yourself enough room for the assembly process
- ✓ Have the following tools: Flat Head Screwdriver, #2 Phillips Head Screwdriver and Hammer
- ✓ Caution: If using a power drill or power screwdriver for screwing, please be aware of to slow down and stop when screw is tight. Failure to do so may result in stripping the screw. (Assembly speed can be increased by using electric screwdriver)

Helpful Hints

PEOPLE NEEDED FOR ASSEMBLY: 1-2

- Open your item in the area you plan to keep it to avoid excessive heavy lifting.
- Identify, sort and count the parts before attempting assembly.
- Compression dowels are lightly tapped in with a hammer.
- Slides are labeled with an **R** (right) and **L** (left) for proper placement.
- Make sure to always face the point on the top of the Cam Lock towards the outer edge.
- If there is a back panel in the package, please install it to make sure your unit is complete and sturdy.
- Please fix all the screws provided for the back panel which can enhance product stability. If it is difficult to fix it when tightening, it can be fixed with the help of a hammer and then tightened.
- Do NOT use harsh chemicals or abrasive cleaners on this item.
- Never push, pull, or drag your furniture.

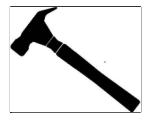
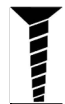

Board Identification

Not actual size

1

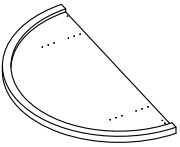

Upper left panel
Qty:1

2

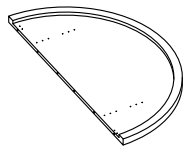

Upper right panel
Qty:1

3

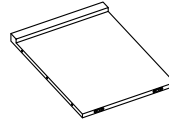

Middle panel A
Qty:1

4

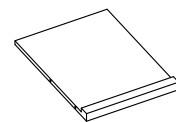

Middle panel B
Qty:1

5

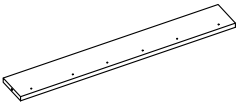

Front and back panels
of the box
Qty:2

6

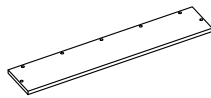

Left and right side panels
of the box
Qty:2

7

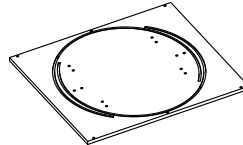

Bottom of the box
Qty:1

8



Floor
Qty:1

9

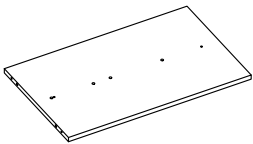

Lower left board
Qty:2

10

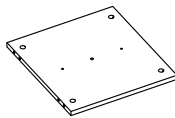

Lower right board
Qty:1

11

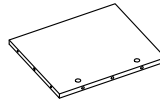

Back panel
Qty:1

12



Roll-up door A
Qty:2

13

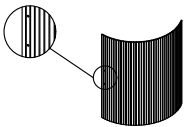

Roll-up door B
Qty:2

14

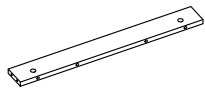

Lower left board
Qty:2

15

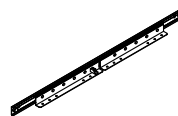

Sliding rail
Qty:2

Part List

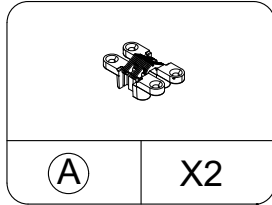

Hinge

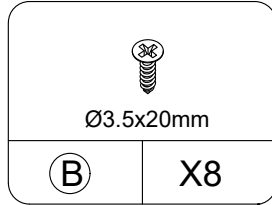

SCREW
spare:1

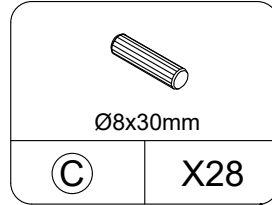

WOOD DOWEL
spare:2

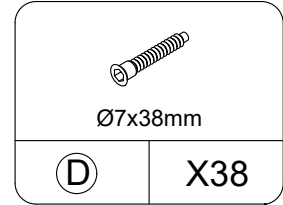

SCREW
spare:2

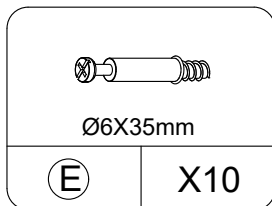

CAM BOLT
spare:1

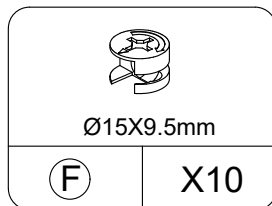

CAM LOCK
spare:1

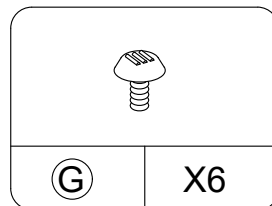

FOOT MAT
spare:1

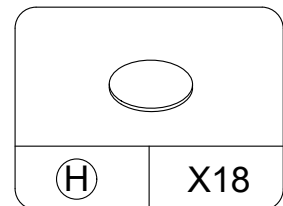

HOLE PASTE
spare:2

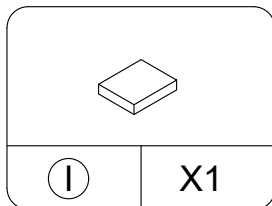

WAX BLOCK

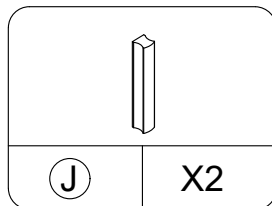

SHAKE HANDS

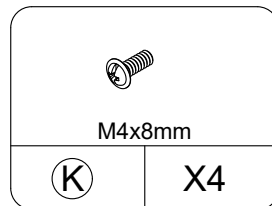

SCREW

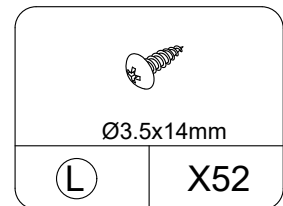

SCREW
spare:5

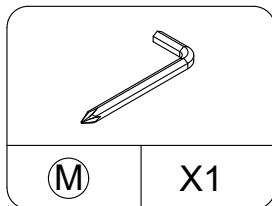

SCREWDRIVER

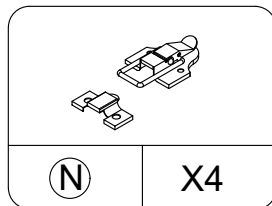

BUCKLE

Part List

Cam Lock Fastening System

Insert the cam bolt into the hole first, then insert the cam lock and lock it.

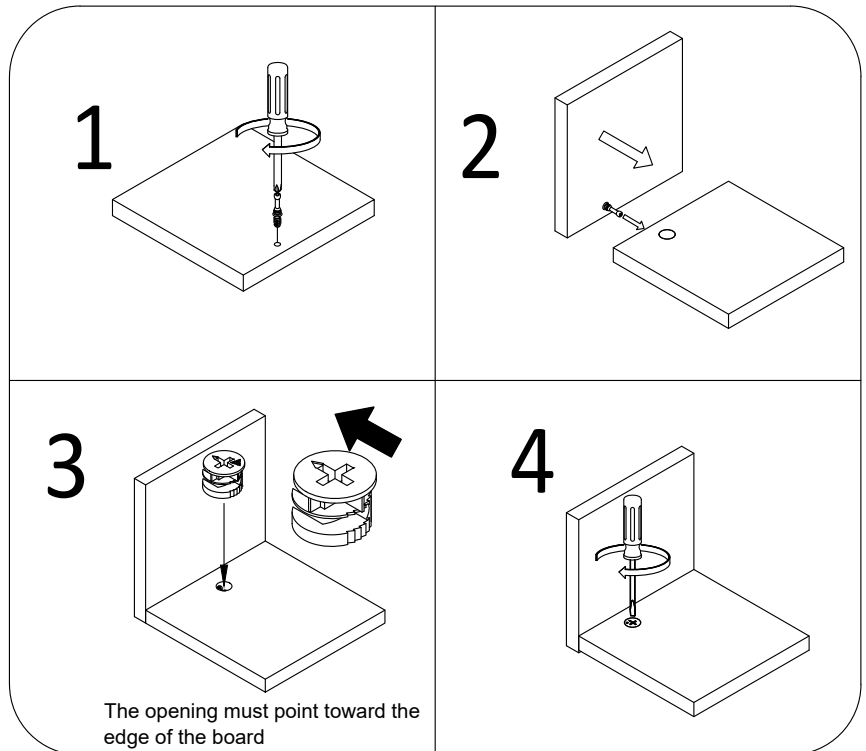

Board Identification

Not actual size

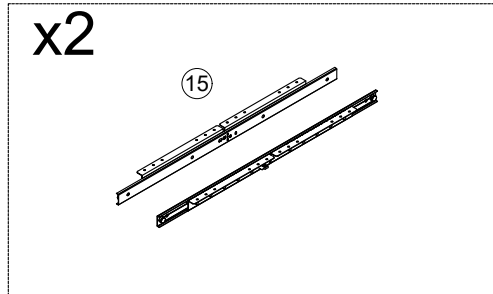
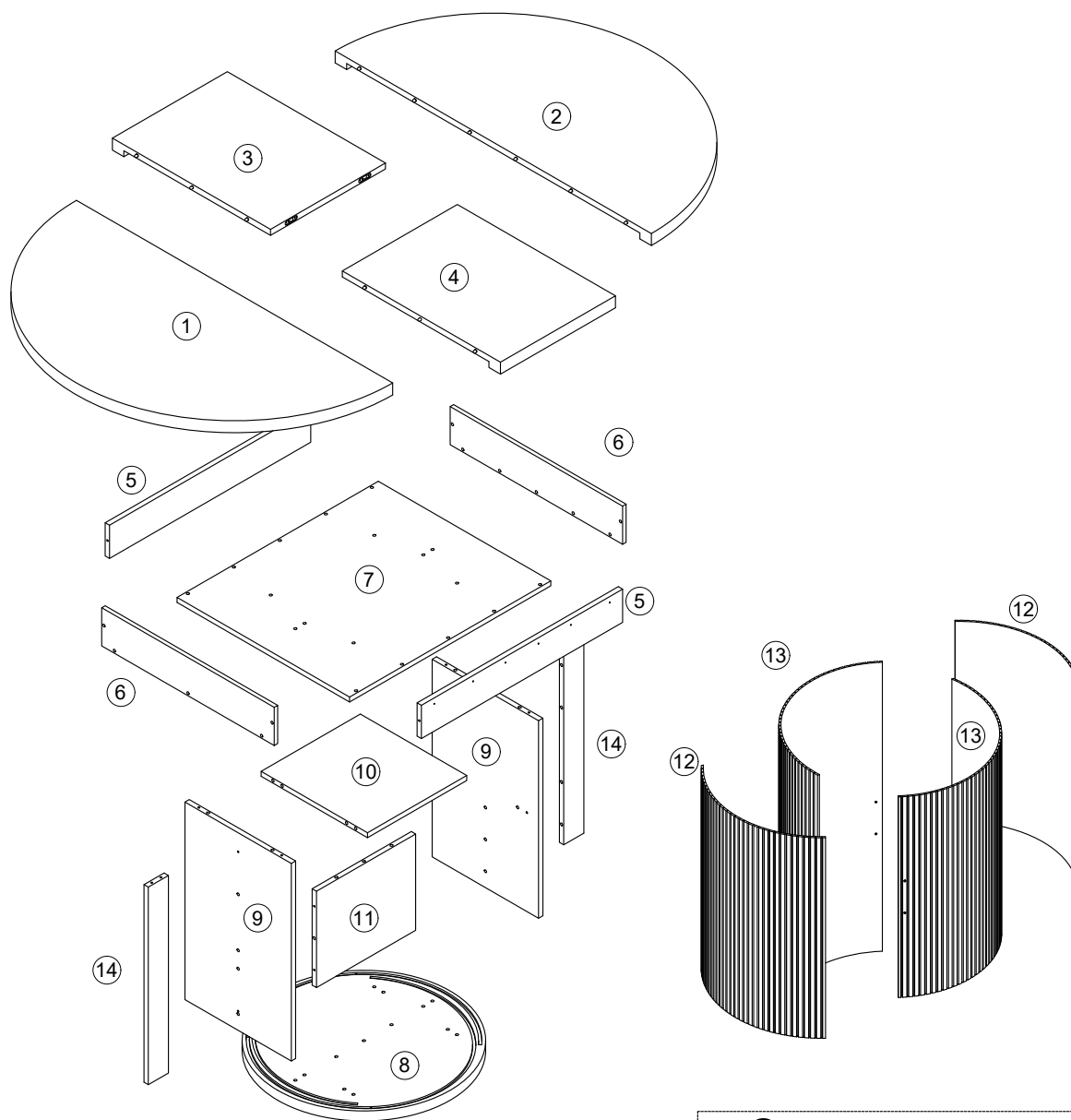

1

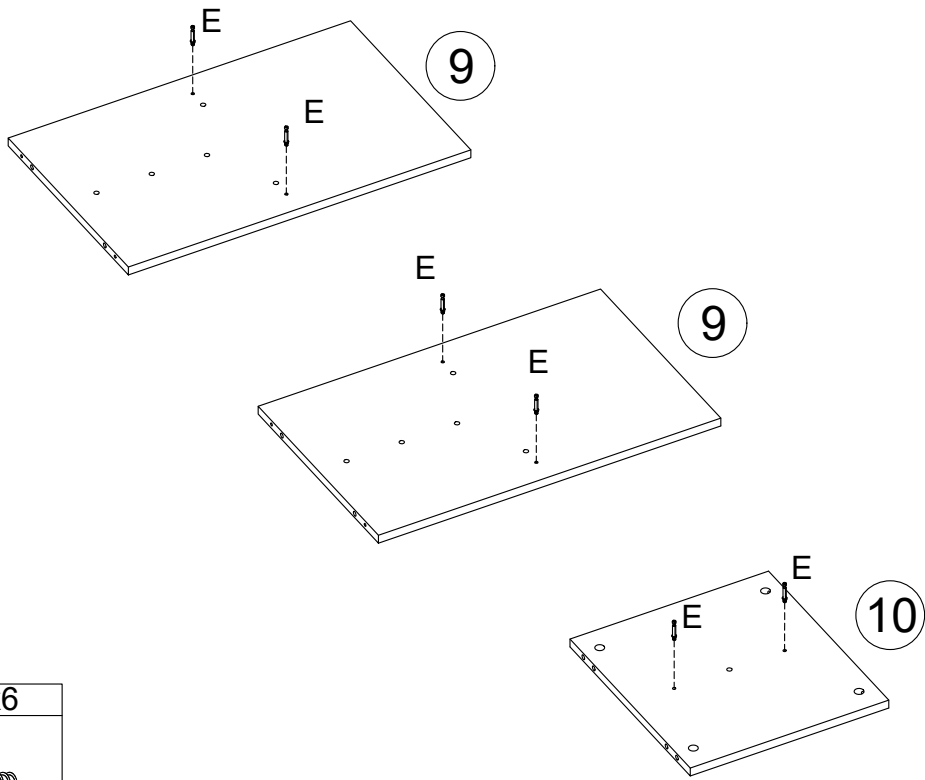

E	x6
<p>Ø6x35mm</p>	

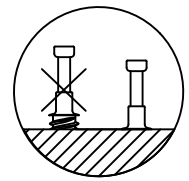



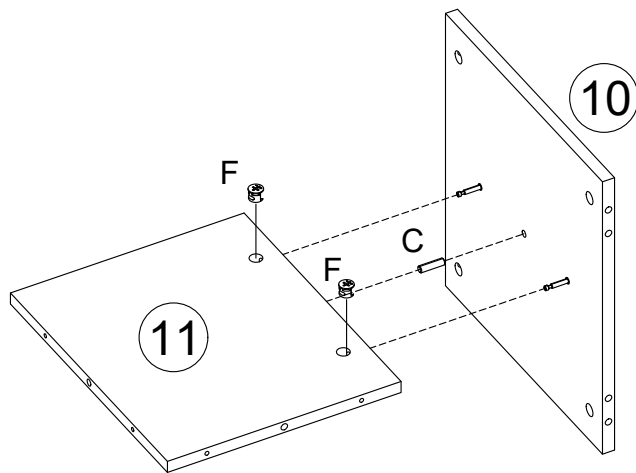

2

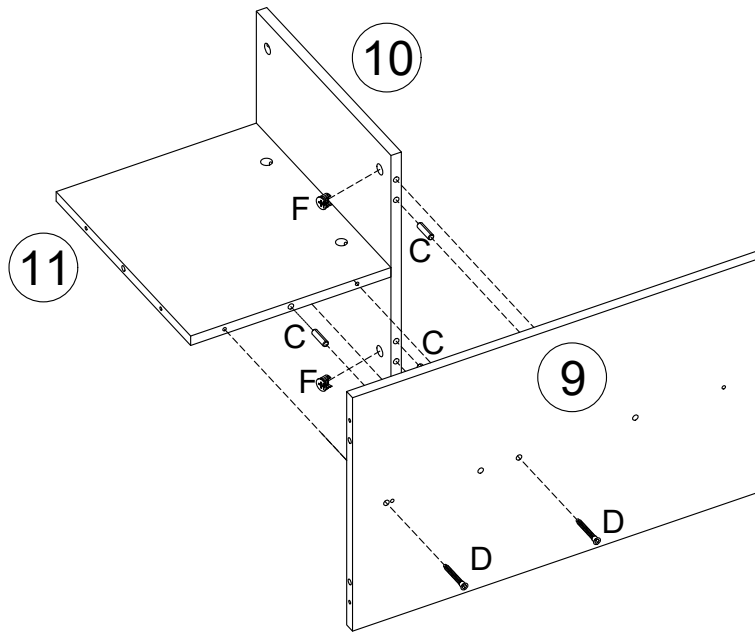

C	x1	F	x2
<p>Ø8x30mm</p>		<p>Ø15x9.5mm</p>	



3

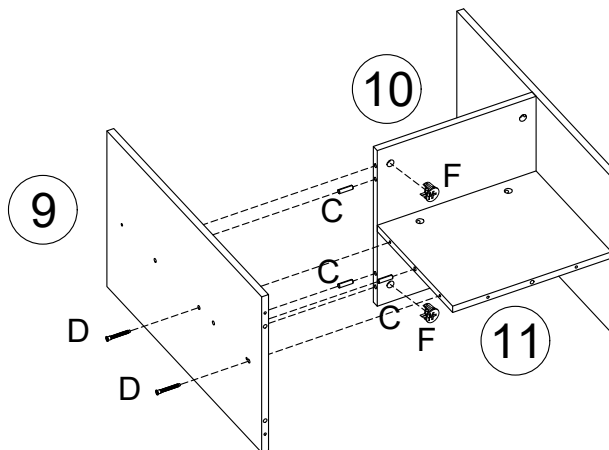

D	x2		
			
Ø7x38mm			
C	x3	F	x2
			
Ø8x30mm		Ø15x9.5mm	

4



D	x2		
			
Ø7x38mm			
C	x3	F	x2
			
Ø8x30mm		Ø15x9.5mm	

5

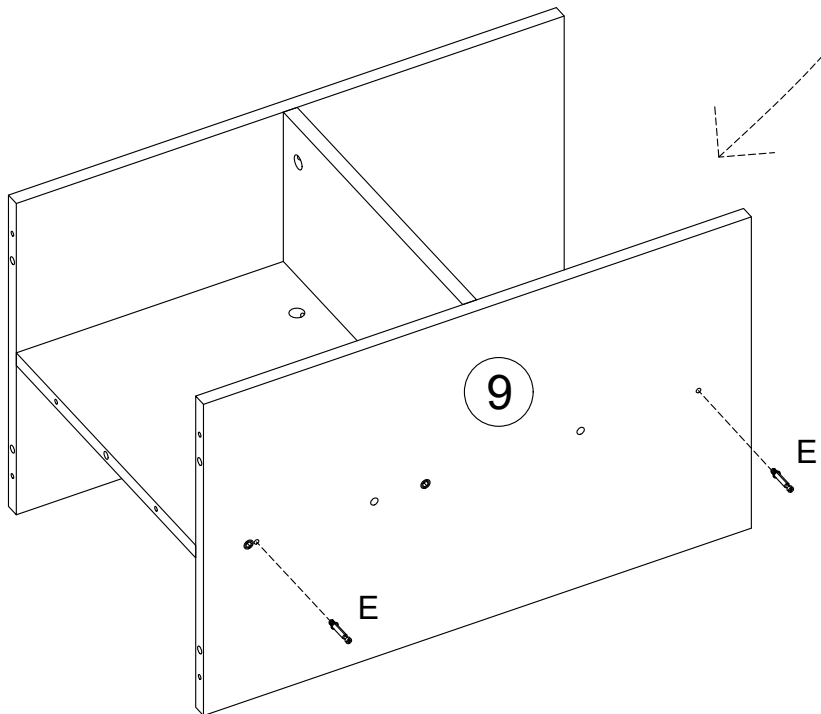
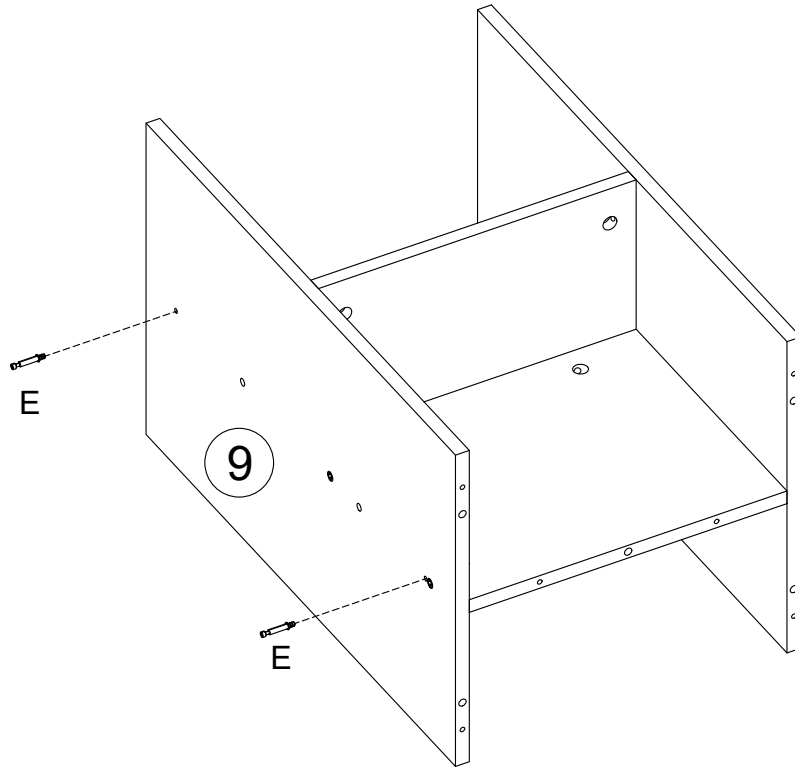

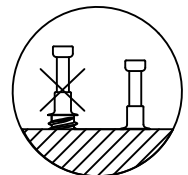

E	x4
Ø6x35mm	

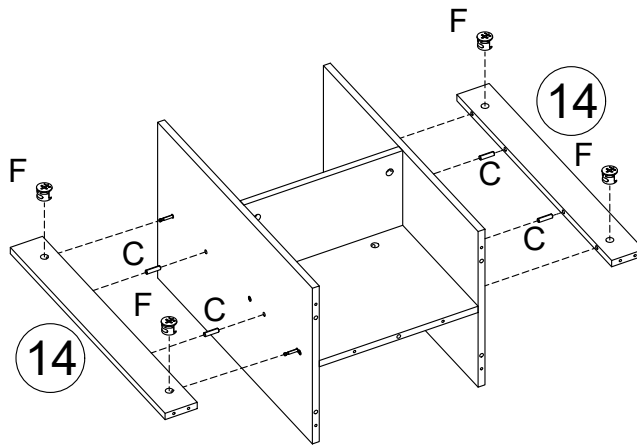

7



C	x4	F	x4
			
Ø8x30mm		Ø15x9.5mm	

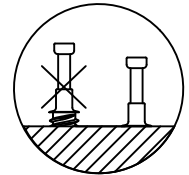

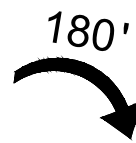
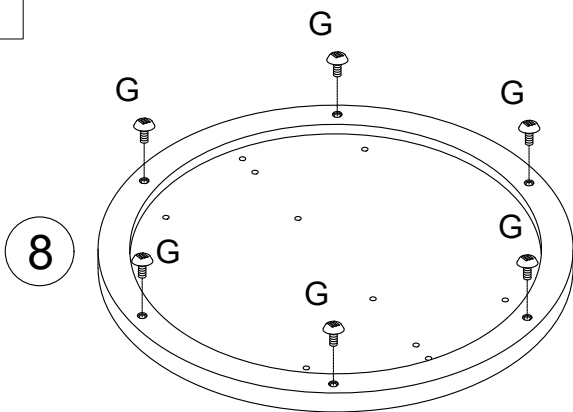

8

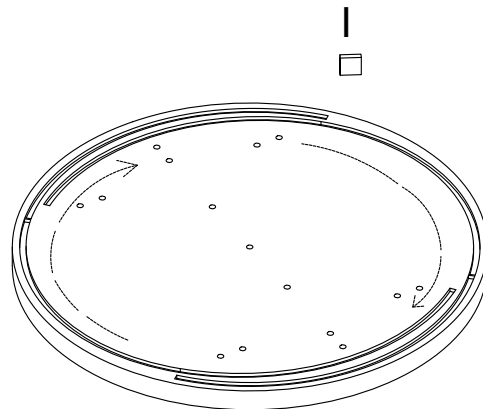

lubricate the sliding groove with wax block



G	x6	I	x1
			

9

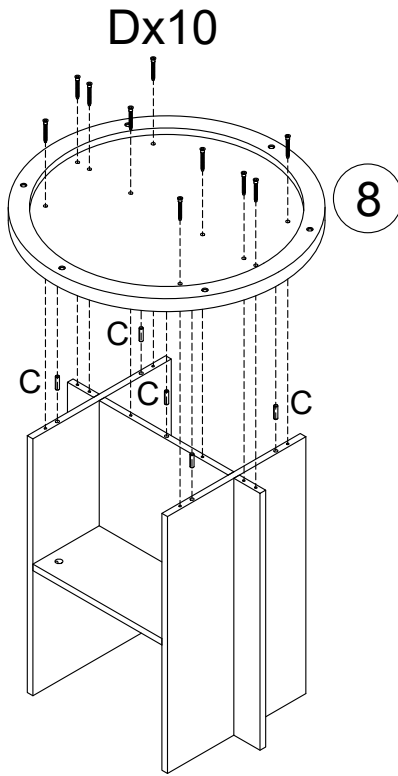
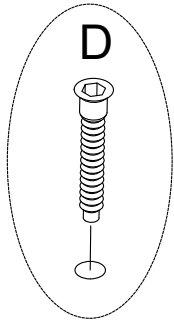

D	x10	C	x5
Ø7x38mm		Ø8x30mm	

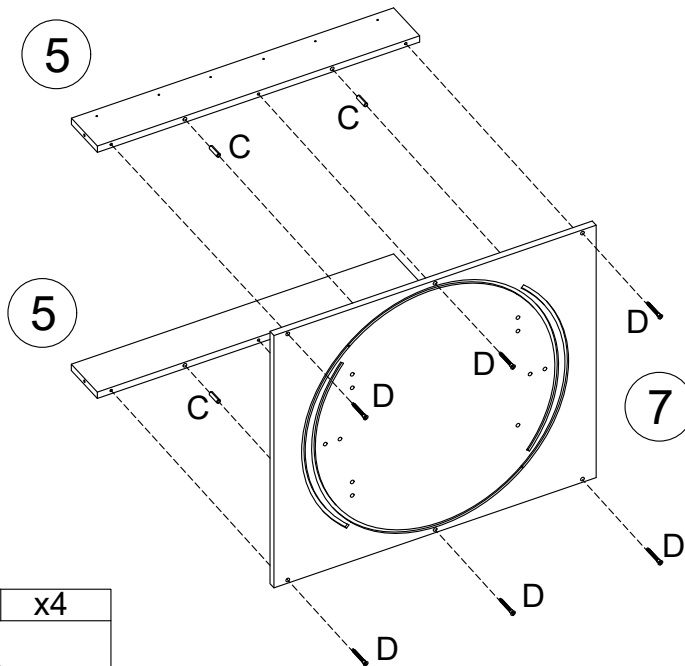

10



D	x6	C	x4
Ø7x38mm		Ø8x30mm	

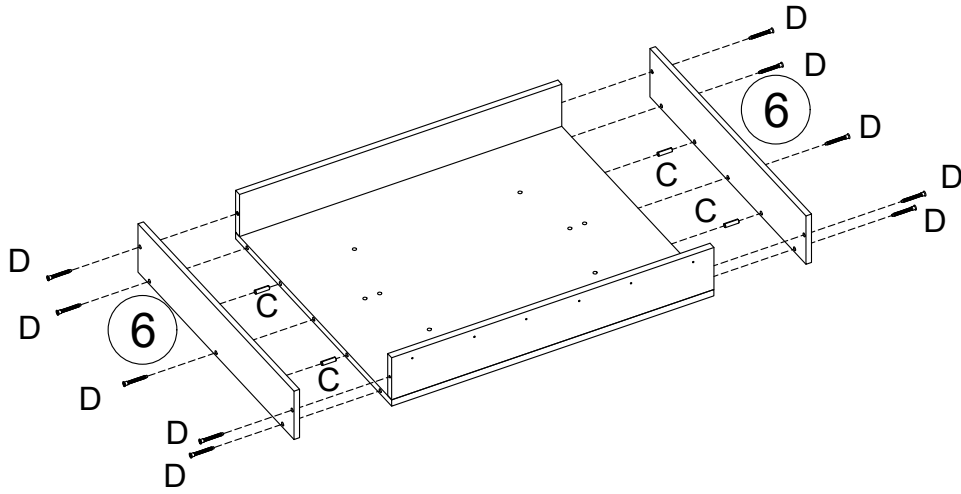

11

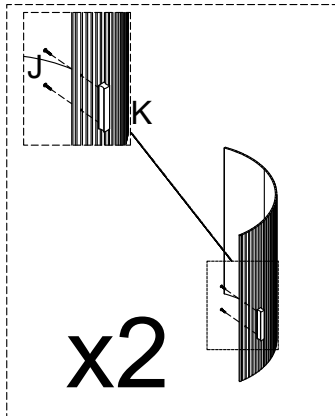

D	x10	C	x4
			
Ø7x38mm		Ø8x30mm	

12



J	x2
	
K	x4
	
M4x8mm	

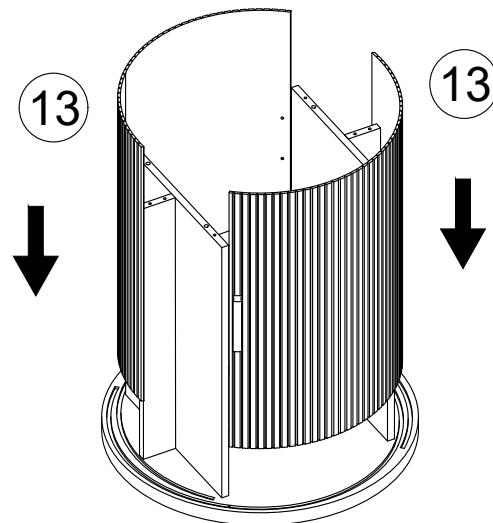

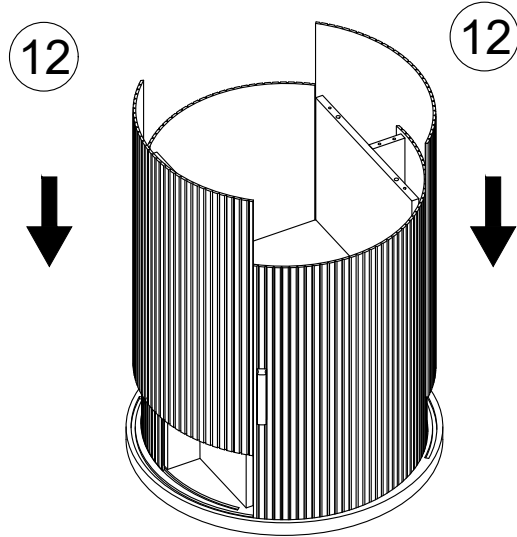

13

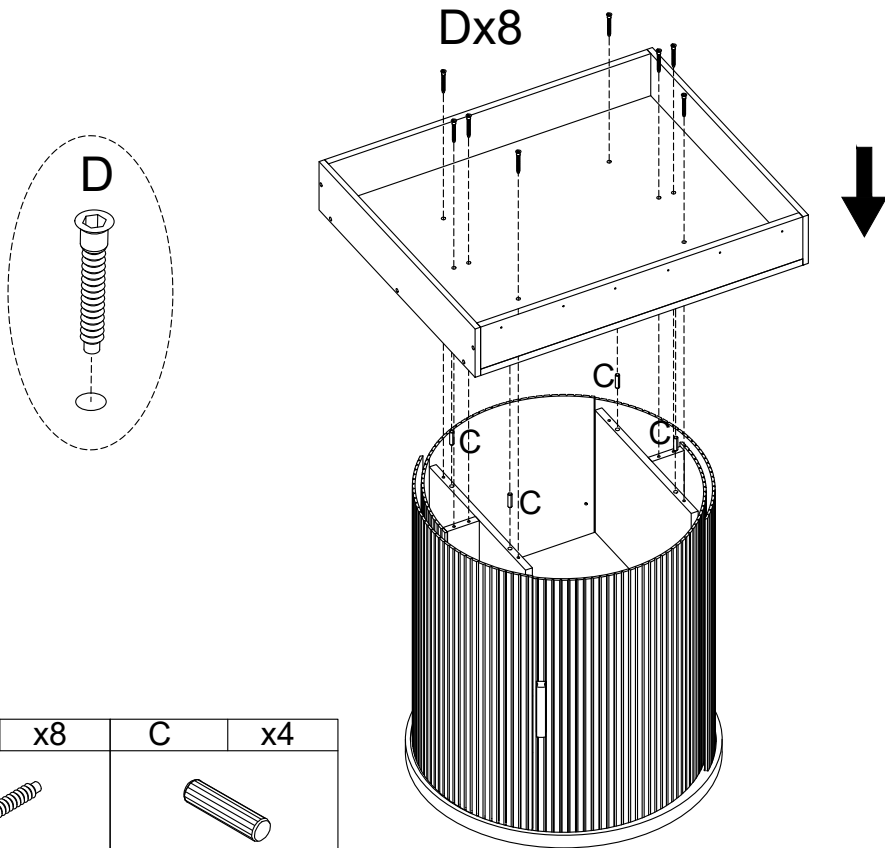

14



D	x8	C	x4
			
Ø7x38mm		Ø8x30mm	

15

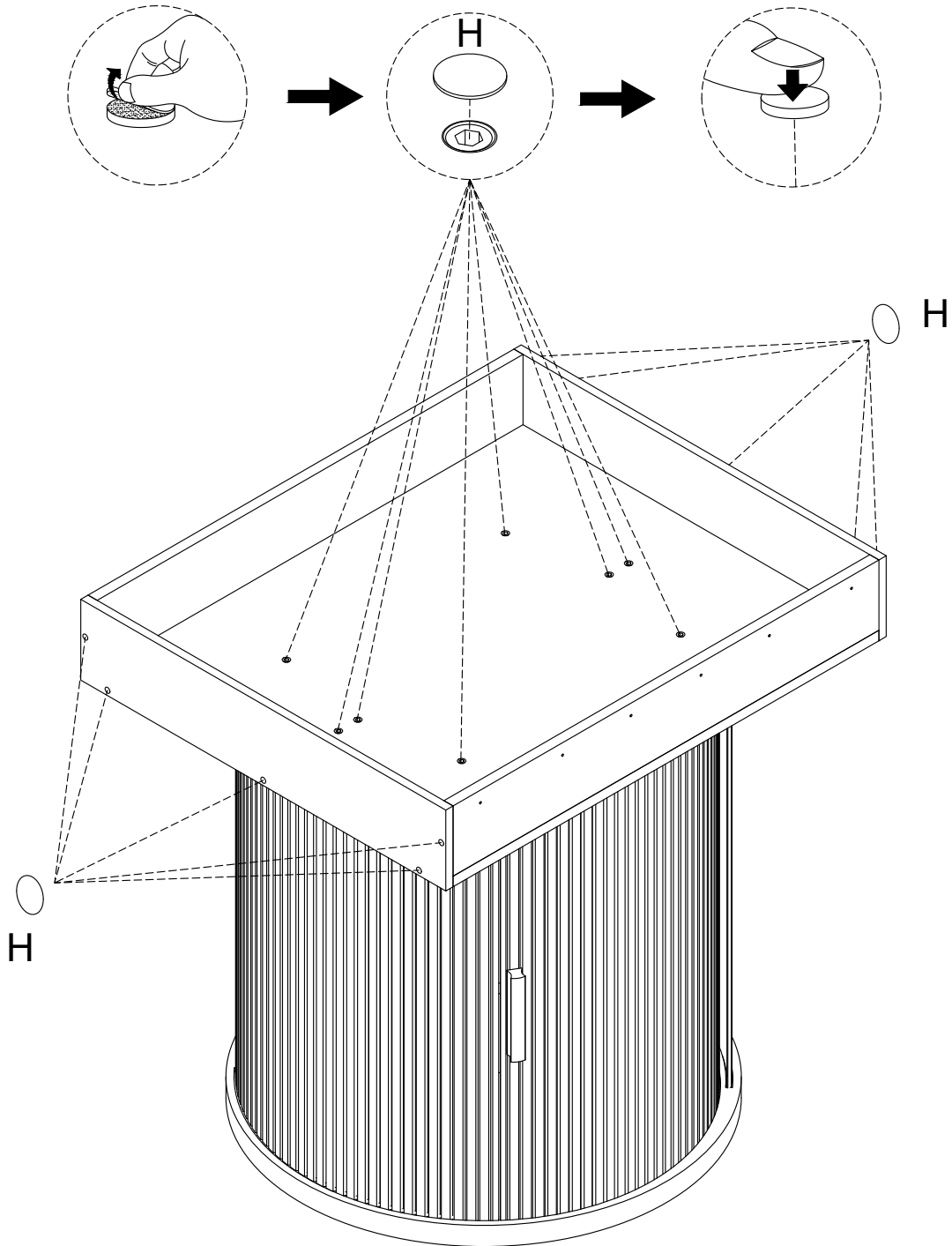

H	x18
Ø20mm	

16

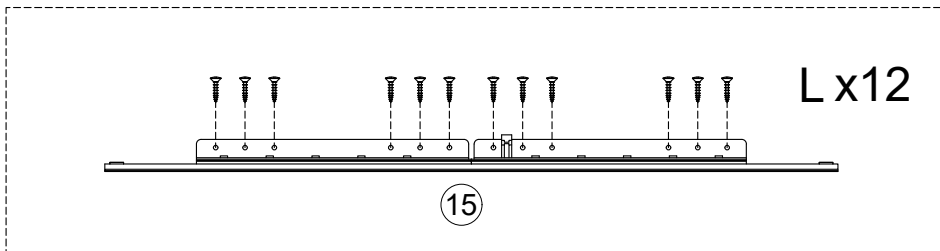
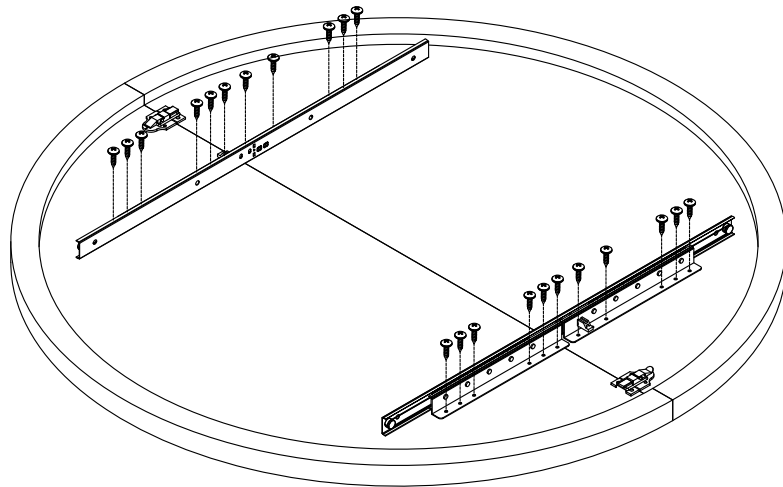
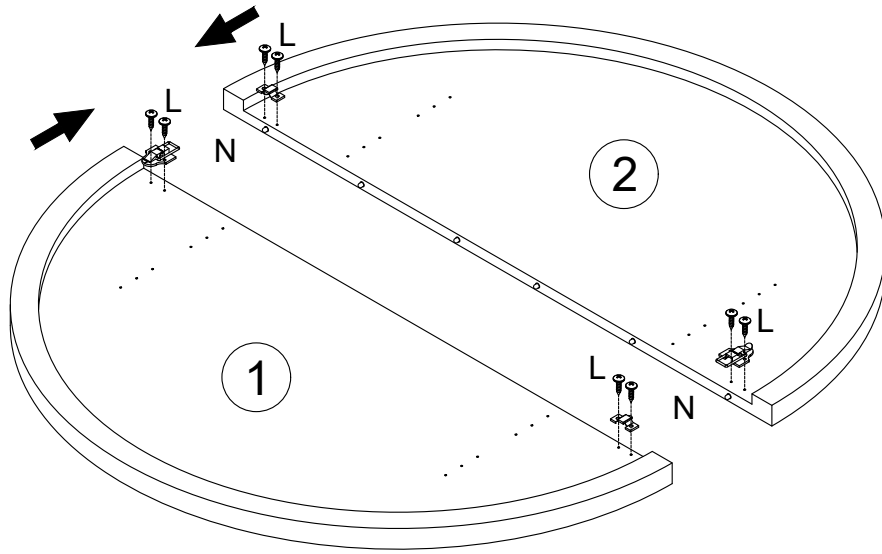

x2

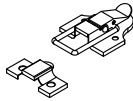
L	x32	N	x2
			
Ø3.5x14mm			

17

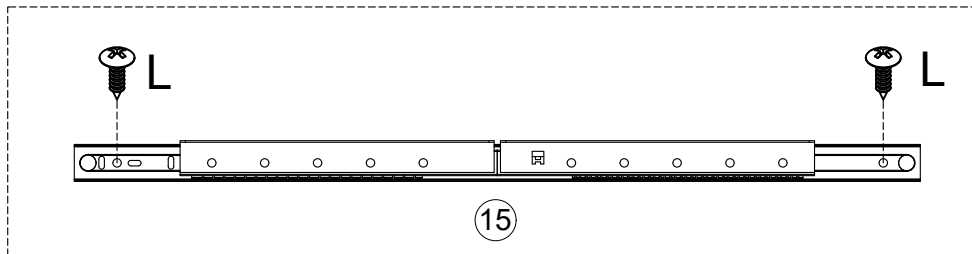
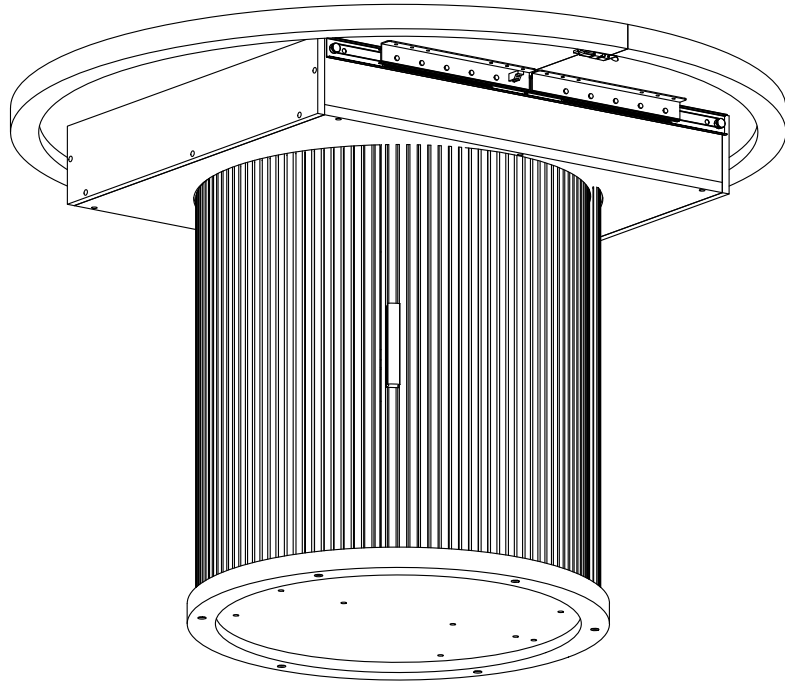

x2

L	x4
	
Ø3.5x14mm	

18

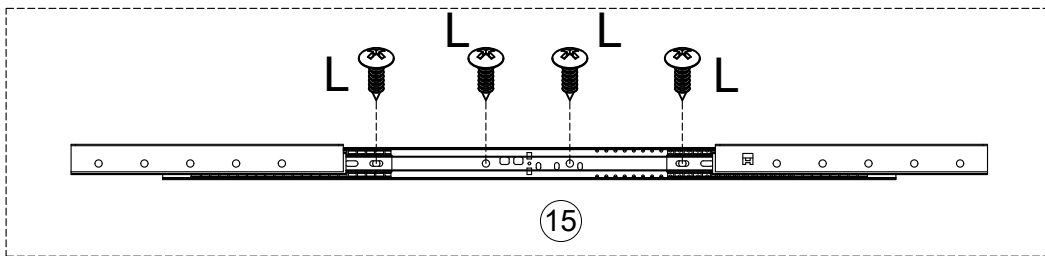
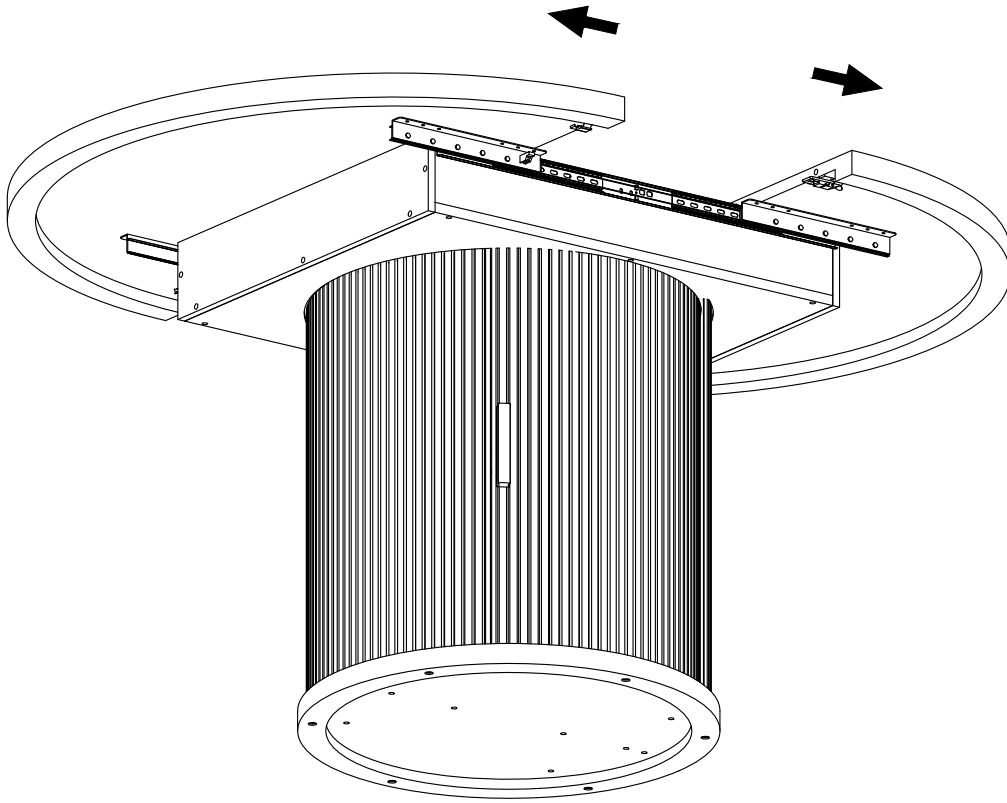



x2

L	x8
	
Ø3.5x14mm	

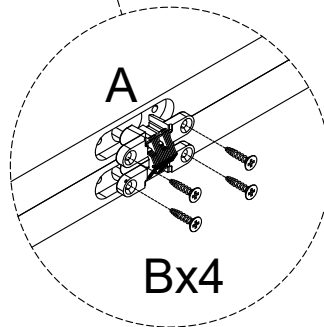
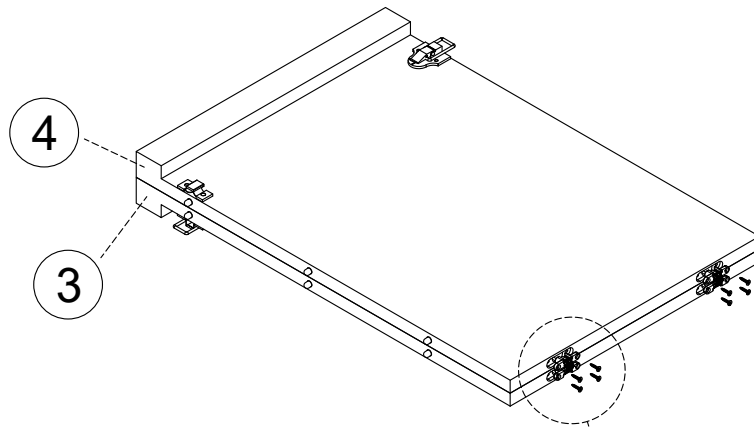
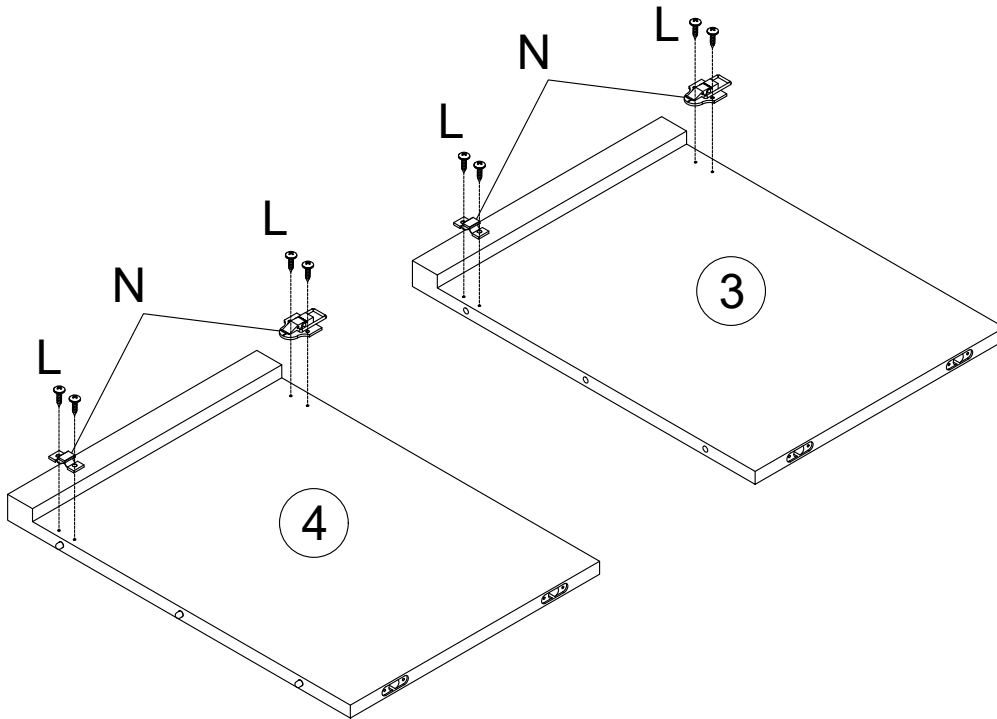
19

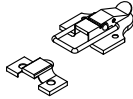
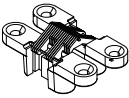

L	x8	N	x2
			
Ø3.5x14mm			
A	x2	B	x8
			
		Ø3.5x20mm	

20

