

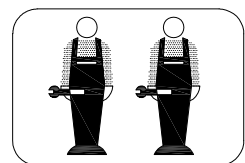

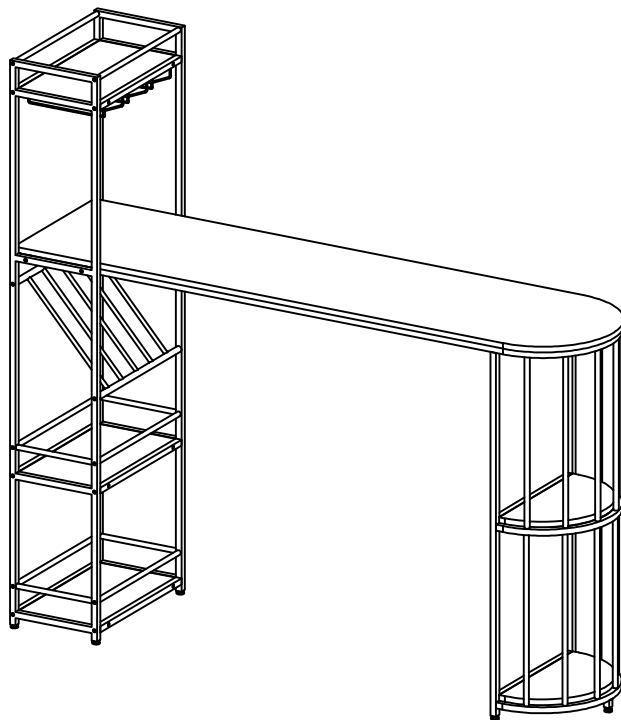

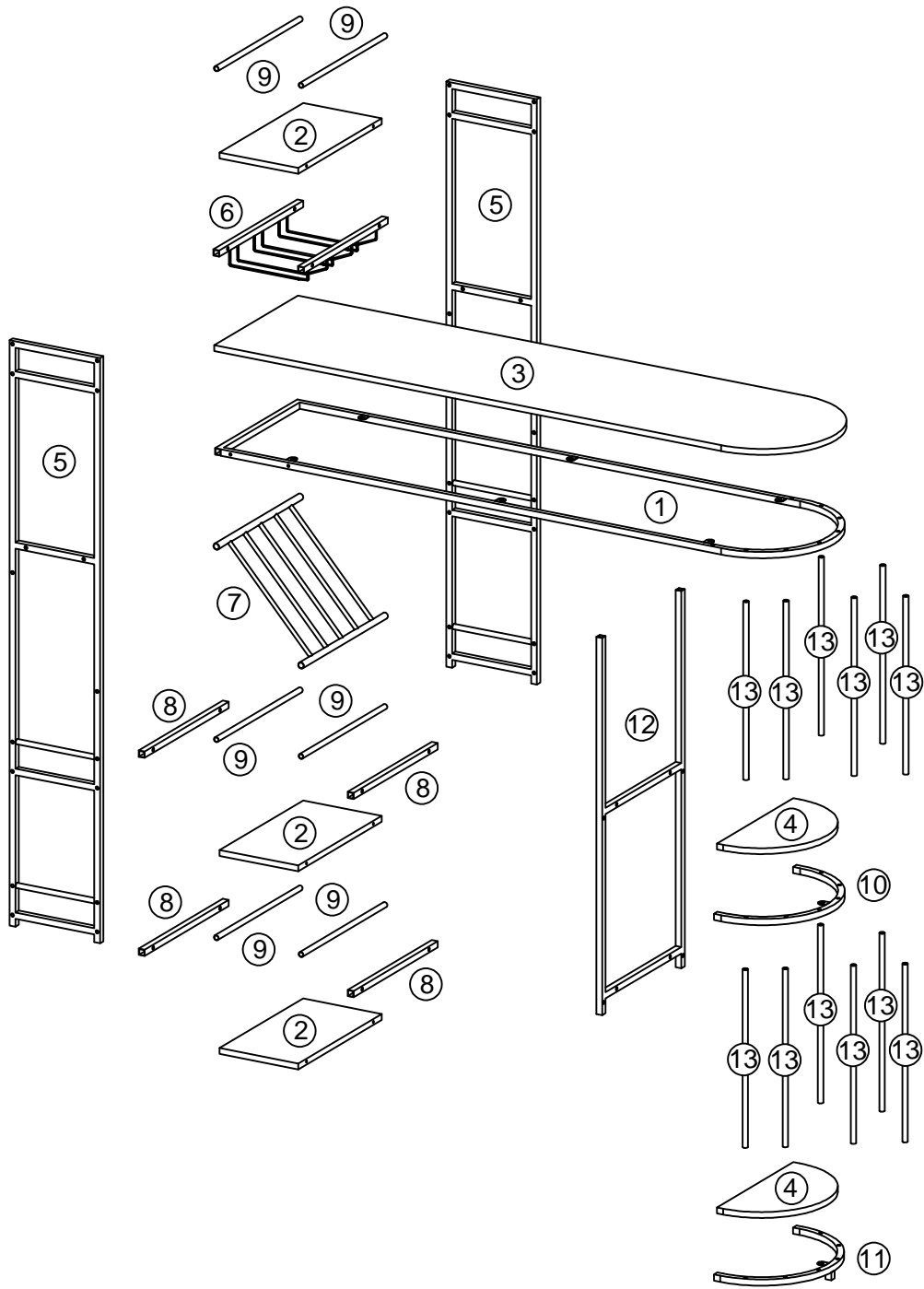





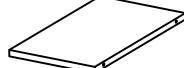

ASSEMBLY INSTRUCTIONS

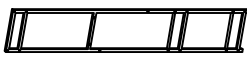
WF322556

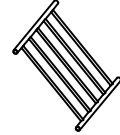
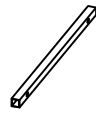









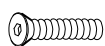

Part List

			
①×1pc	②×3pcs	③×1pc	④×2pcs
			
⑤×2pcs	⑥×1pc	⑦×1pc	⑧×4pcs
			
⑨×6pcs	⑩×1pc	⑪×1pc	⑫×1pc
			
⑬×12pcs			

Hardware List

				
M6×12mm	M6×35mm	φ7×40mm	4×35mm	M6×40mm
(A)×8pcs	(B)×50pcs	(C)×16pcs	(D)×2pcs	(E)×6pcs
				
φ16	φ6×30mm			
(F)×4pcs	(G)×2pcs	(H)×2pcs	(I)×7pcs	(J)×2pcs

Step 1



φ7×40mm

Ⓒ ×12pcs

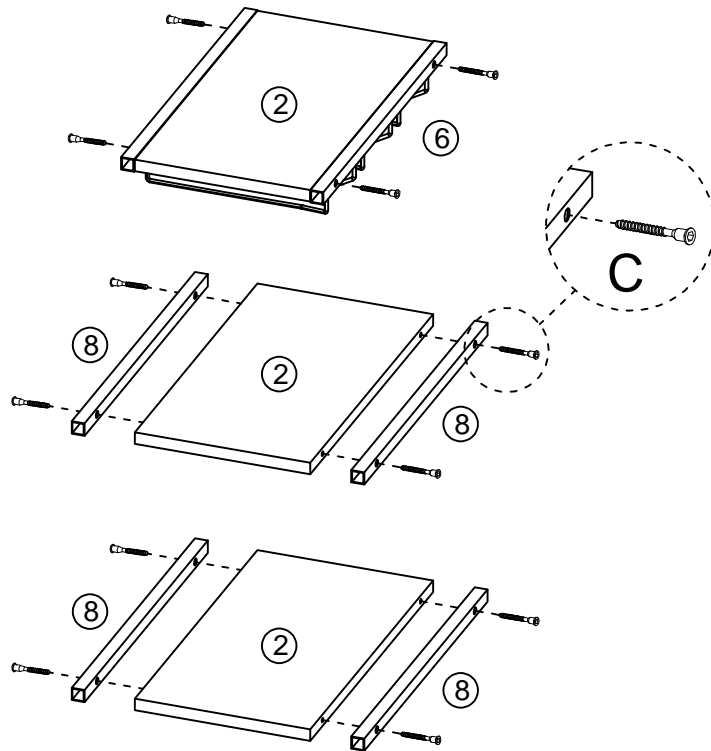



Step 2

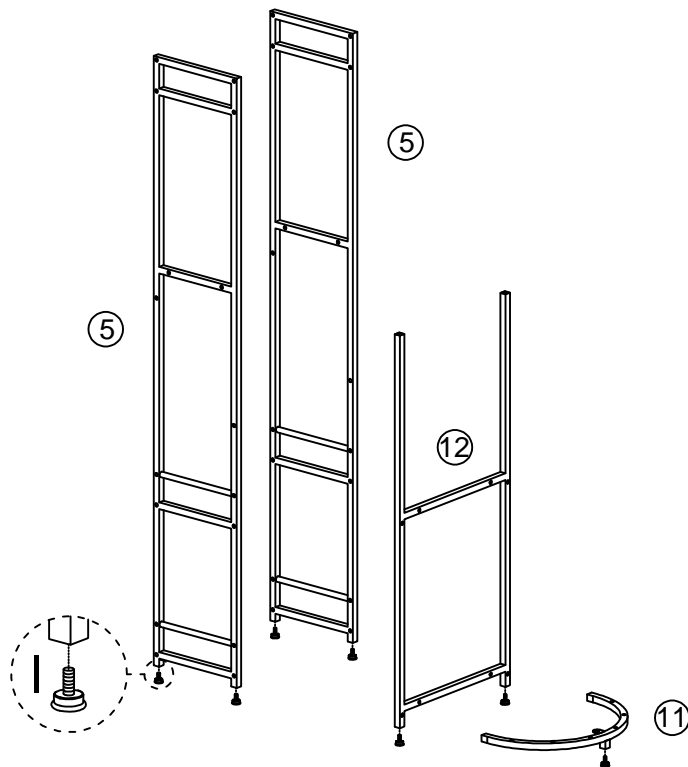

① ×7pcs



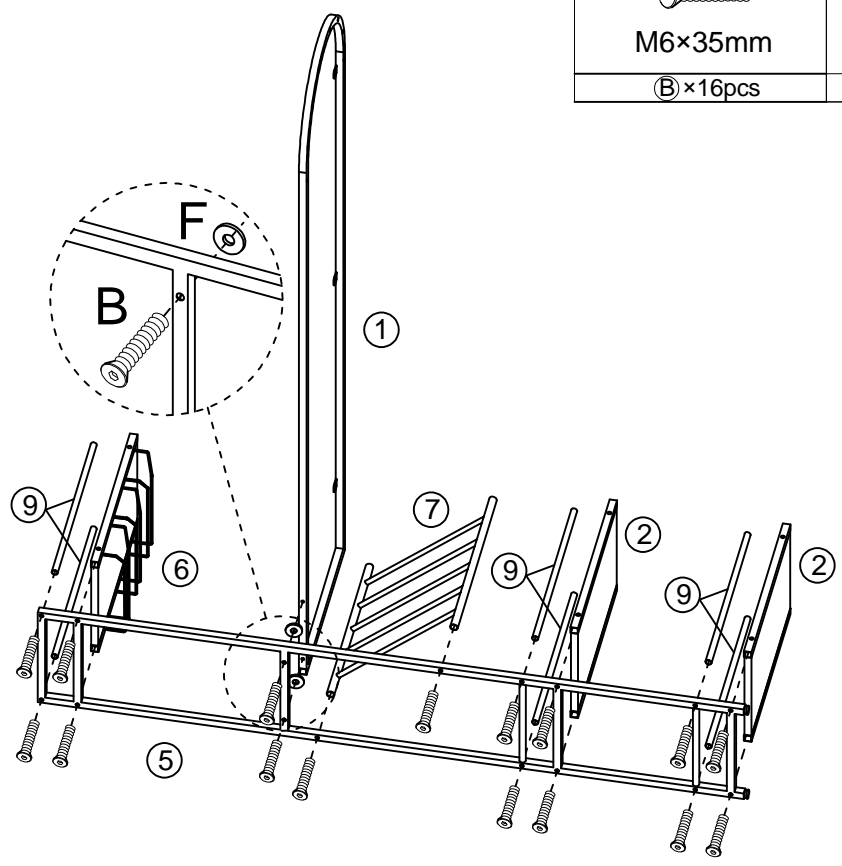

Step 3

	
M6×35mm	φ16
(B)×16pcs	(F)×2pcs



Step 4

	
M6×35mm	φ16
(B)×16pcs	(F)×2pcs

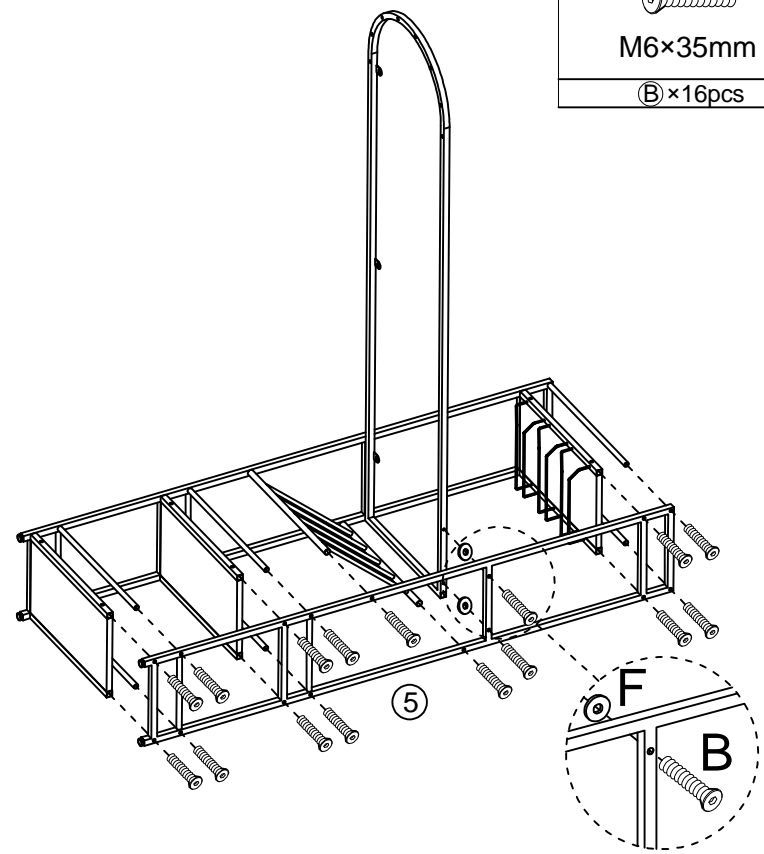

Step 5

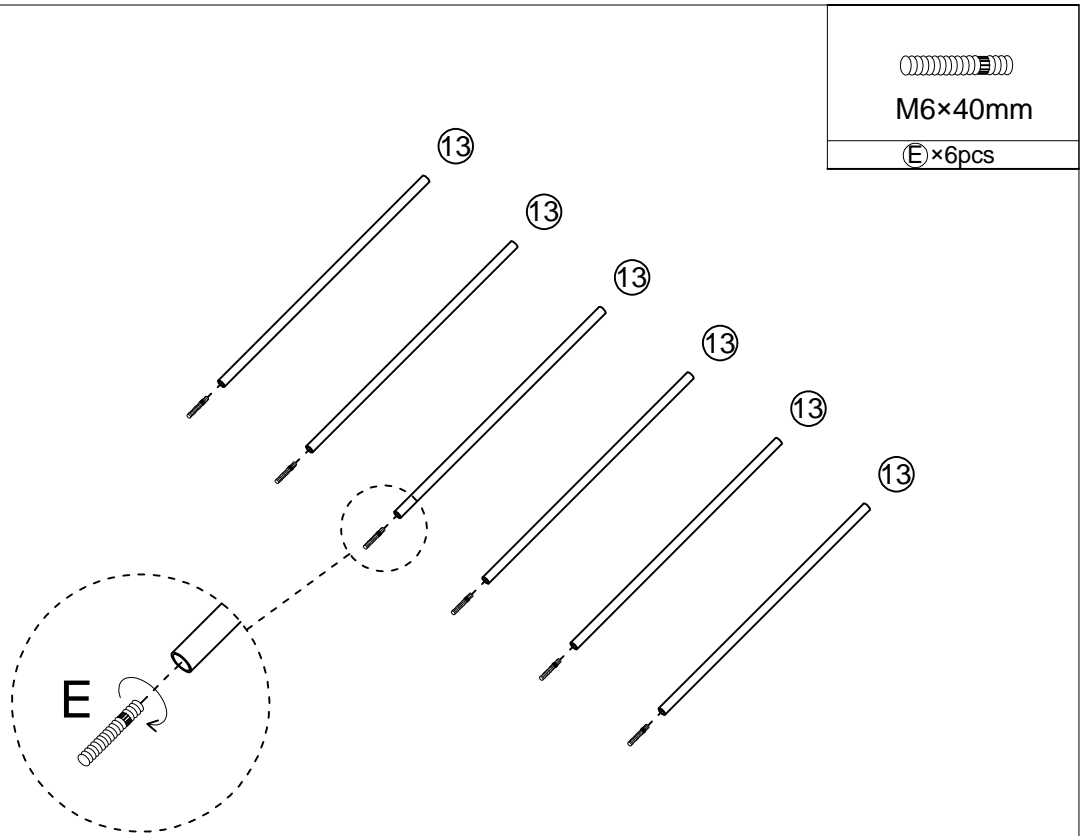

Step 6

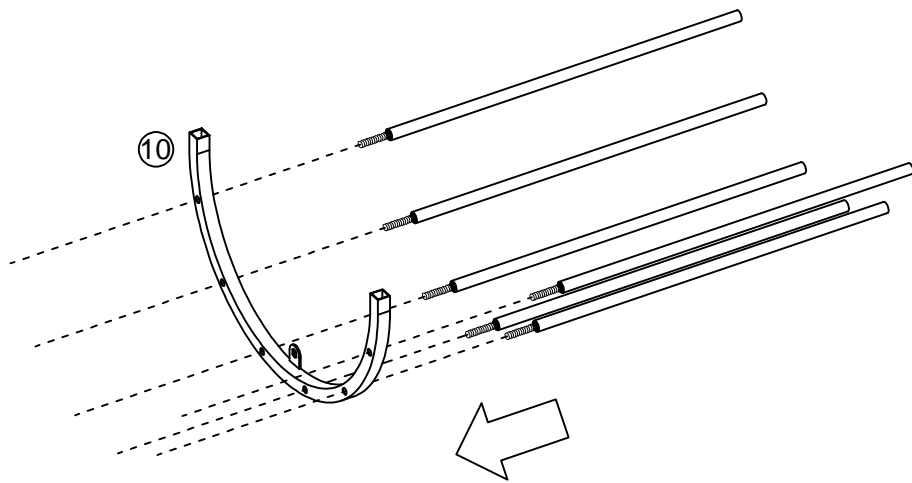

Step 7

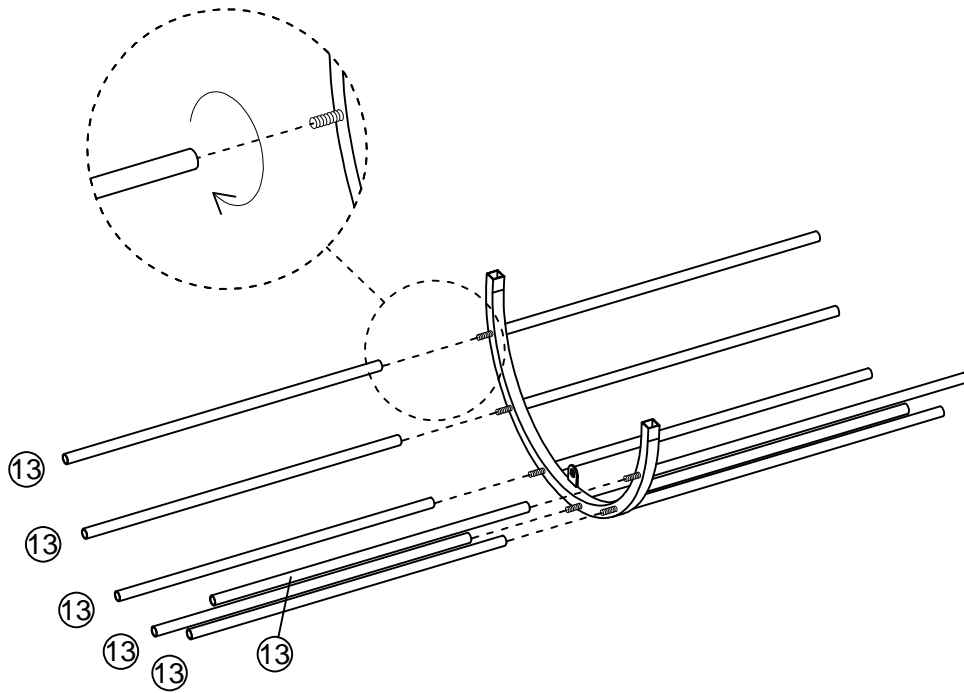

Step 8

M6×35mm
Ⓑ×6pcs

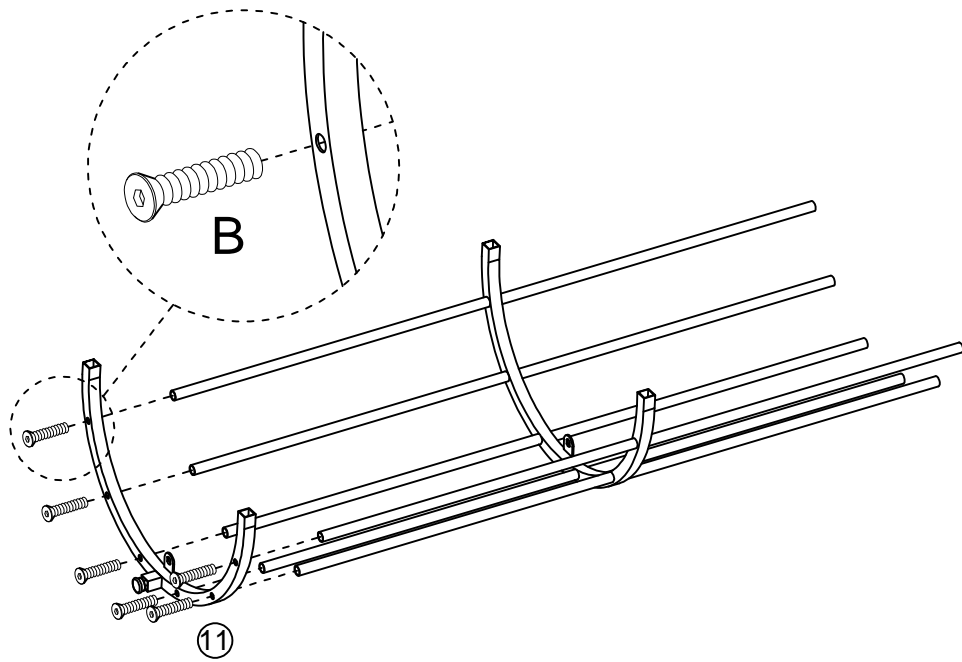

Step 9



φ7×40mm

Ⓒ×4pcs

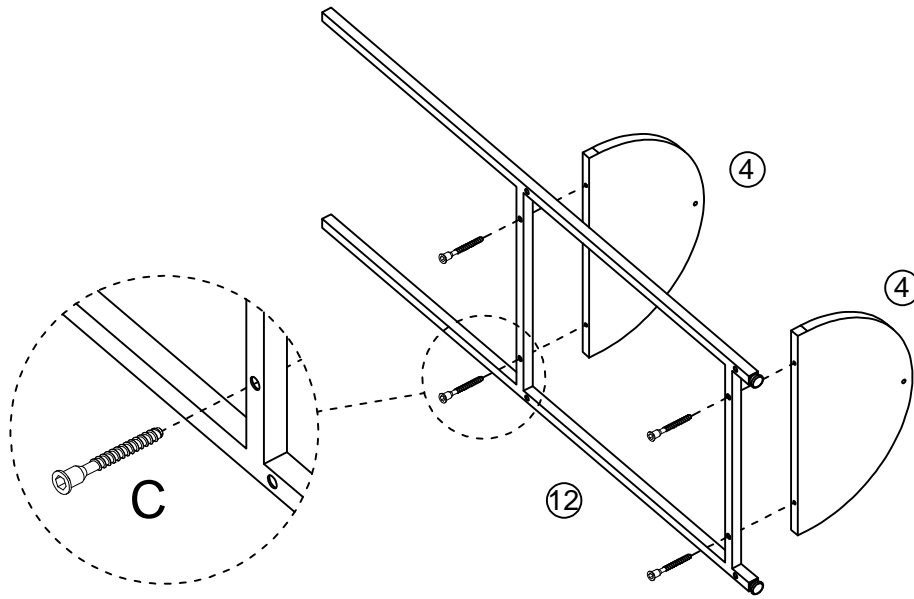

Step 10

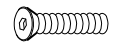

M6×35mm

Ⓑ×4pcs

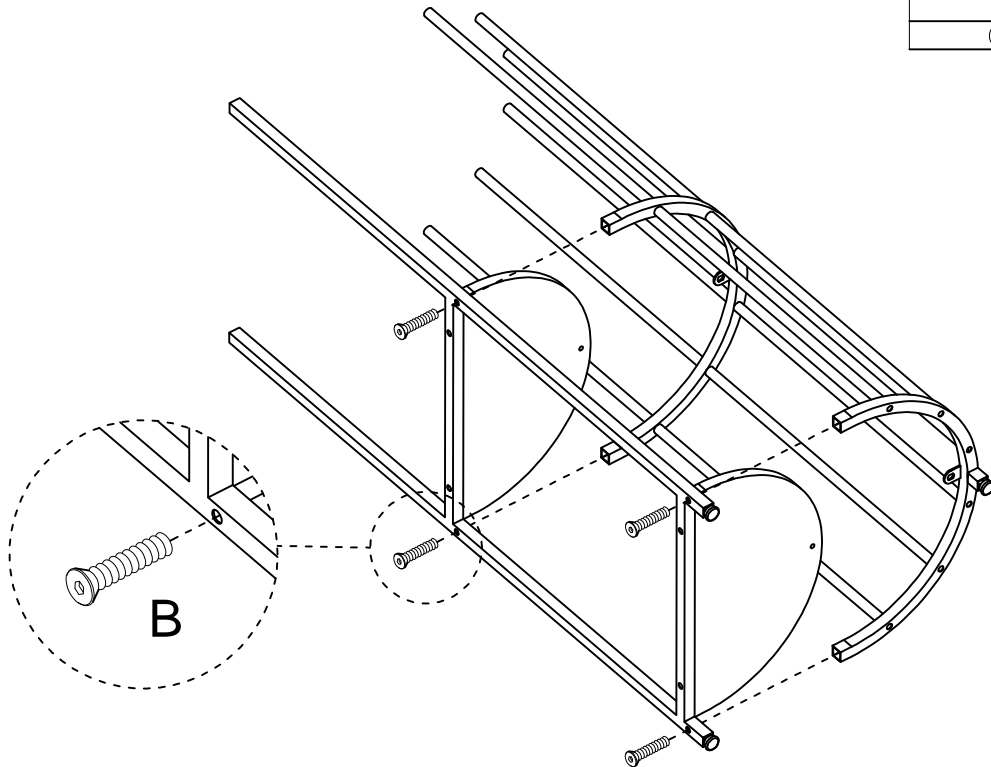

Step 11



M6×12mm

Ⓐ ×2pcs

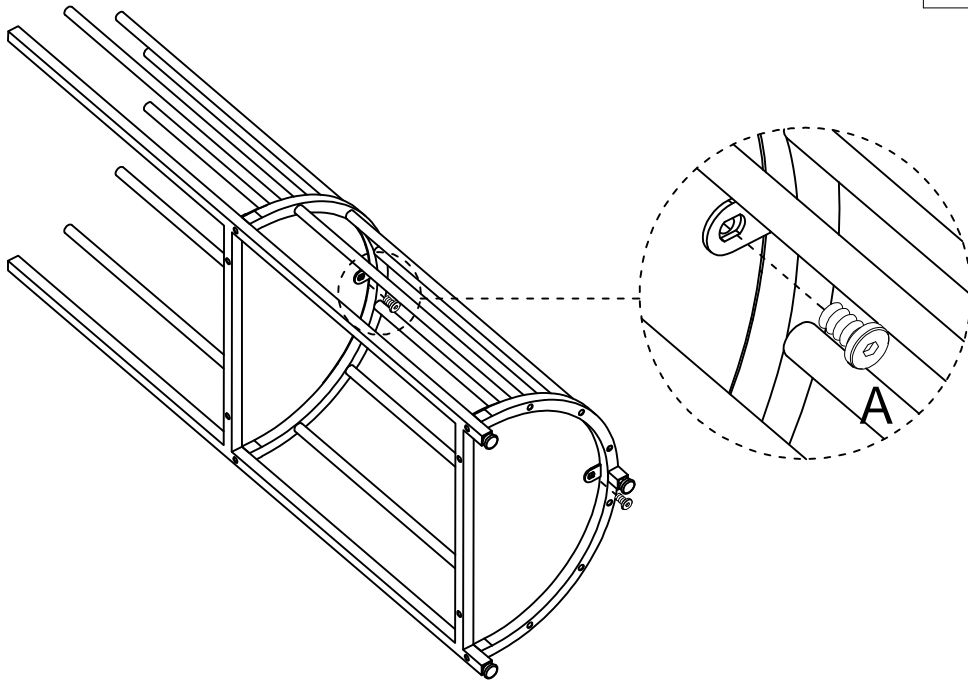

Step 12

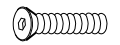

M6×35mm

Ⓑ ×8pcs

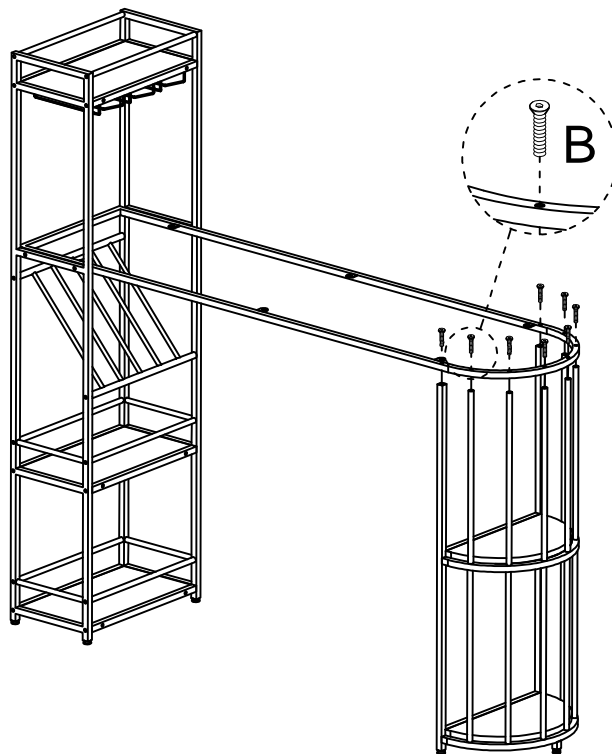

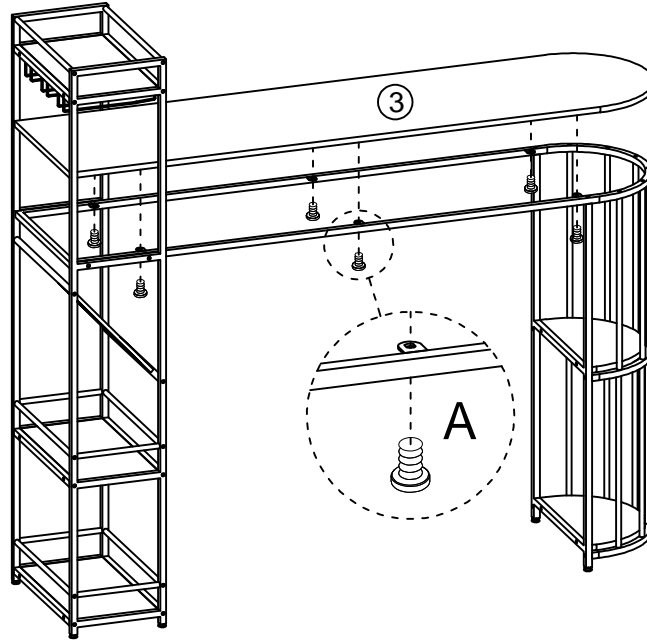

Step 13

M6×12mm
A ×6pcs



Step 14

 4×35mm D ×2pcs	 φ6×30mm G ×2pcs	 H ×2pcs
--	---	--

