

Parts and Damage Replacement Procedure

1. Please inspect your purchase immediately.
2. This procedure covers product purchased from an authorized Reseller and was received in its originally sealed carton.
3. If you find a part missing or damaged, you have a 30-day window in which to order a replacement part from the date on your purchase receipt.
4. You have 3 ways to do this. You will need a copy of your purchase receipt.
 - a. By Fax: Fax the parts order form below and along with your receipt
 - b. By Email: Email the order form and along with your receipt
 - c. By Mail: Fill out the parts order form below and along with a copy of your receipt send it to
5. Once this order is sent in, you will be notified if the part(s) you are requesting can or cannot be shipped within 7-10 business days.

**A COPY OF YOUR PURCHASE RECEIPT OR INVOICE MUST BE ATTACHED TO THIS ORDER FORM.
NO ORDERS WILL BE PROCESSED WITHOUT PROOF OF PURCHASE.**

NAME: _____
ADDRESS: _____ (No Post Office Boxes)
CITY: _____ STATE: _____ ZIP: _____
PHONE: _____ FAX: _____
EMAIL: _____

REASON FOR REPLACEMENT/PLEASE CHECK APPROPRIATE BOX.

- Damaged /scratched, cracked, broken, crushed, etc.
- Mechanical malfunction/ drawer glides, swivel mechanisms, lid stays, etc.
- Missing pieces
- Unfinished surface
- Wrong color
- Other

IF MORE THAN ONE MODEL NUMBER IS LISTED ABOVE, PLEASE SPECIFY THE EXACT MODEL NUMBER OF YOUR ITEM IN THE SPACE PROVIDED BELOW.

Model Number	Part Letter Code	Quantity

ASSEMBLY INSTRUCTIONS

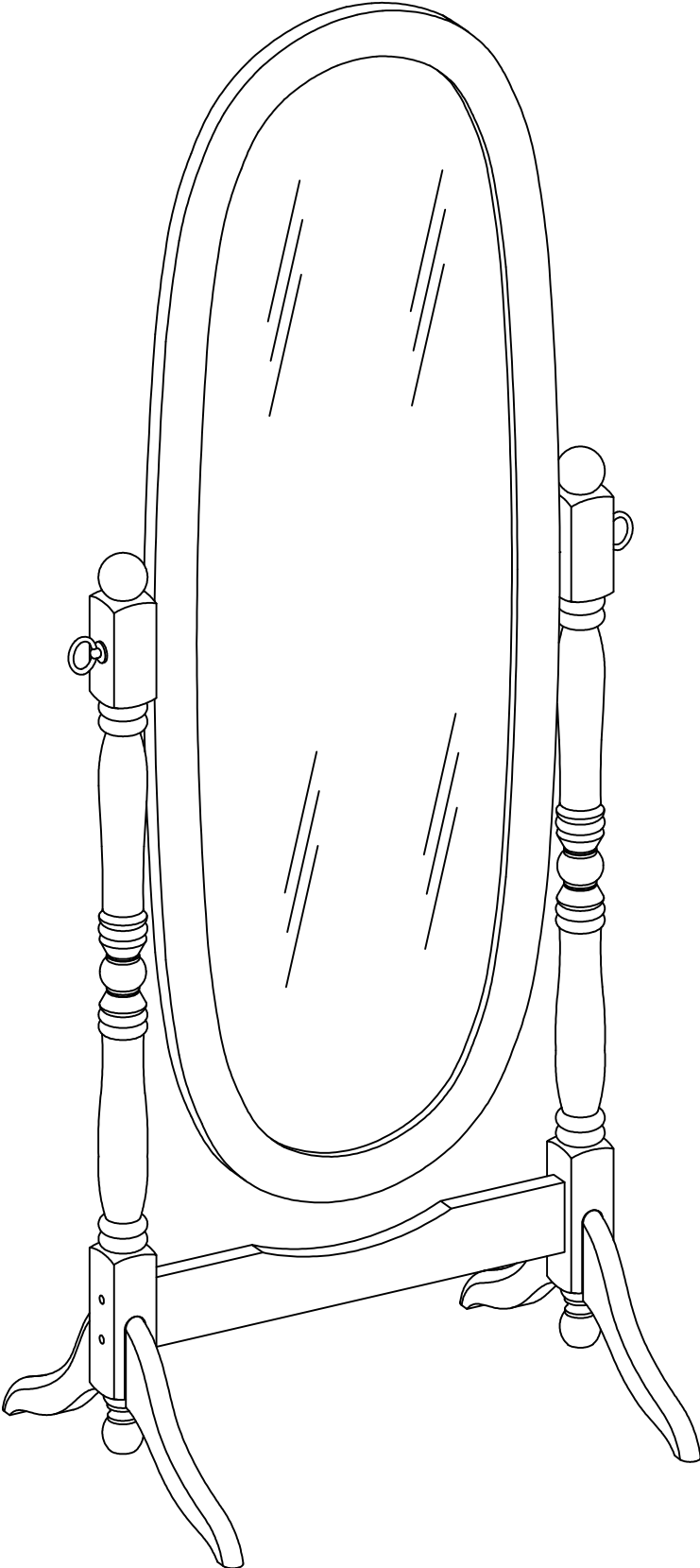

ASSEMBLY INSTRUCTIONS

Parts List

1. MIRROR
1 piece

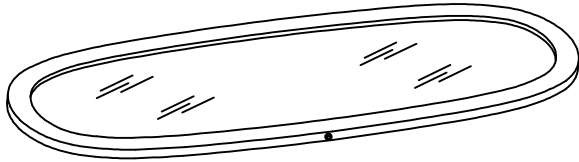

2. PILASTER LEG
2 pieces

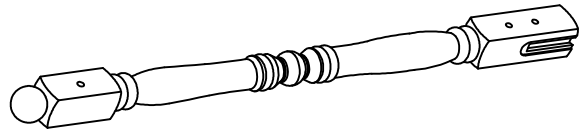

3. CROSSBAR
1 piece



4. BRANCH LEG
4 pieces

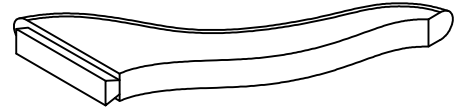

Hardware List

5. LEG LOCKING BRANCH
2 pieces

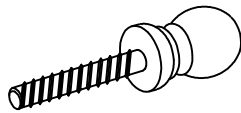

6. TYPE BOLT
2 pieces

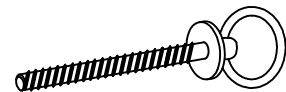

7. BOLT
4 pieces



8. WASHER
2 pieces



ASSEMBLY INSTRUCTIONS

STEP 1

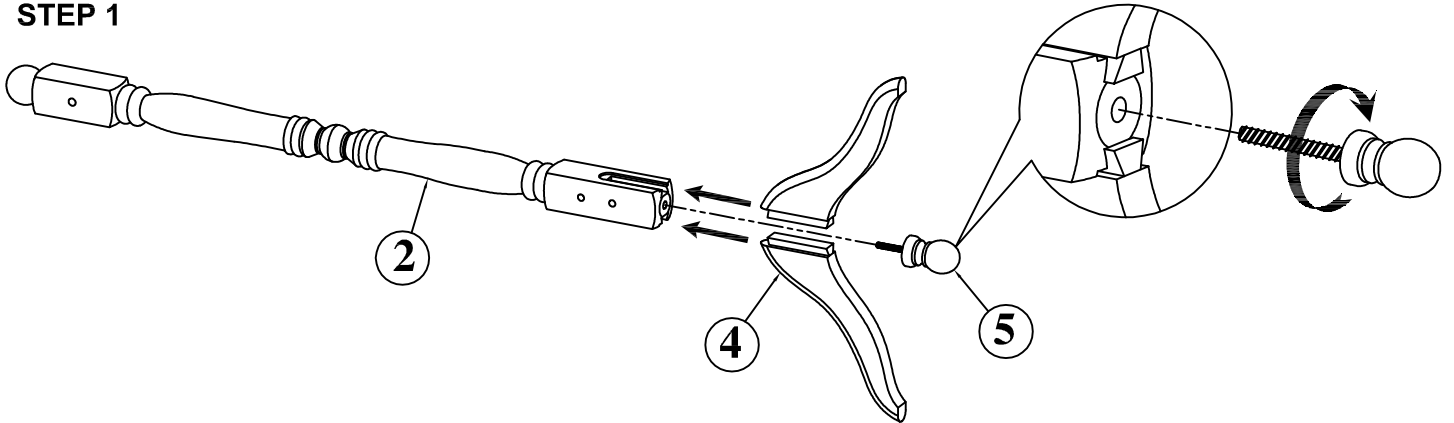

STEP 3

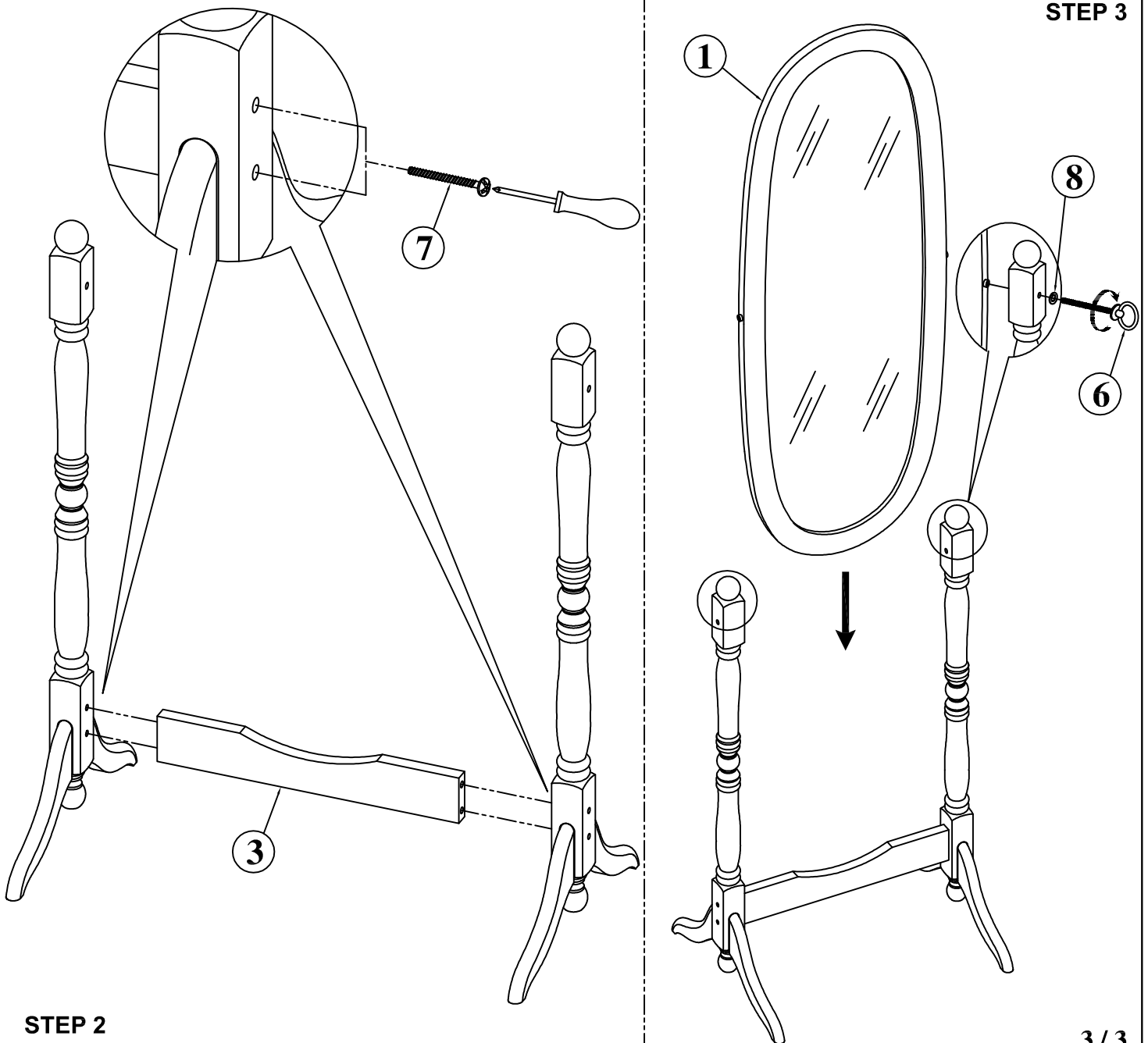

STEP 2