

Assembly Instructions

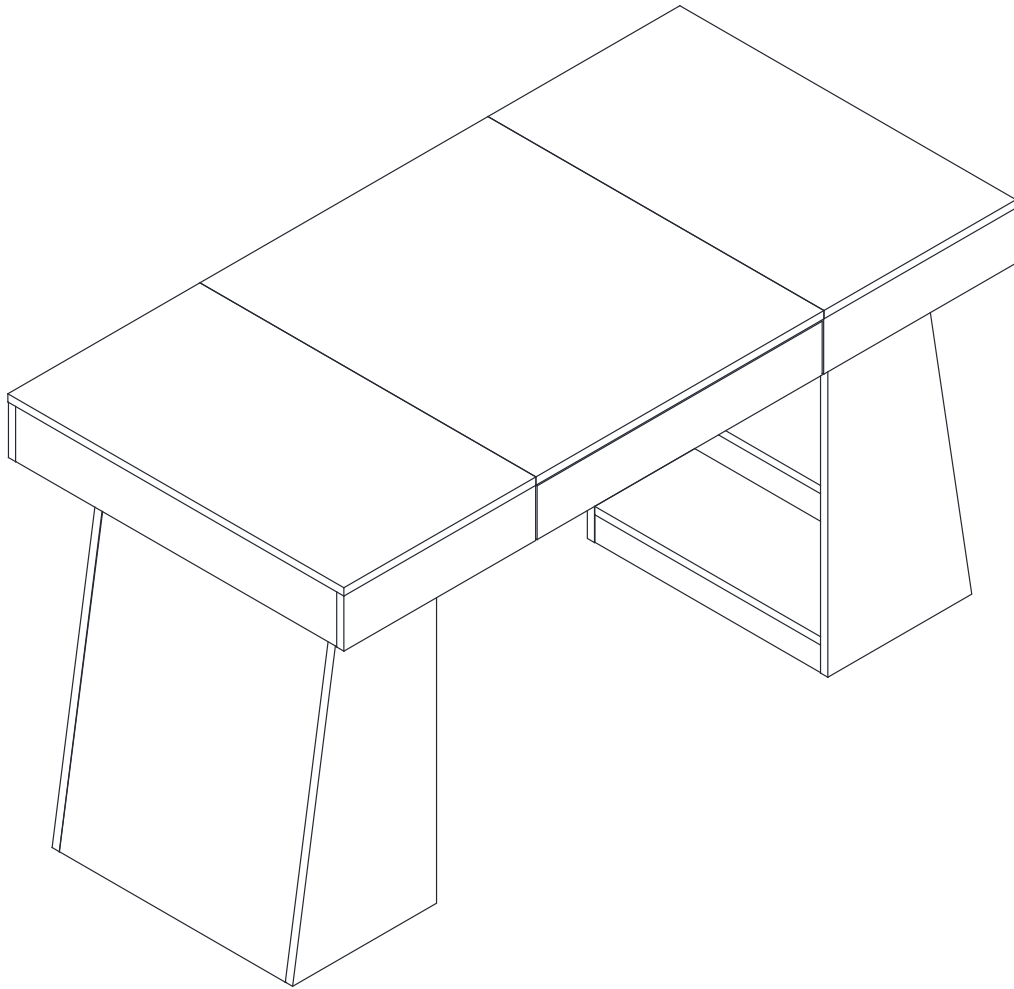

Office Table

Model No.
HOGA-SL0097

Contact Us

We're here to help you.

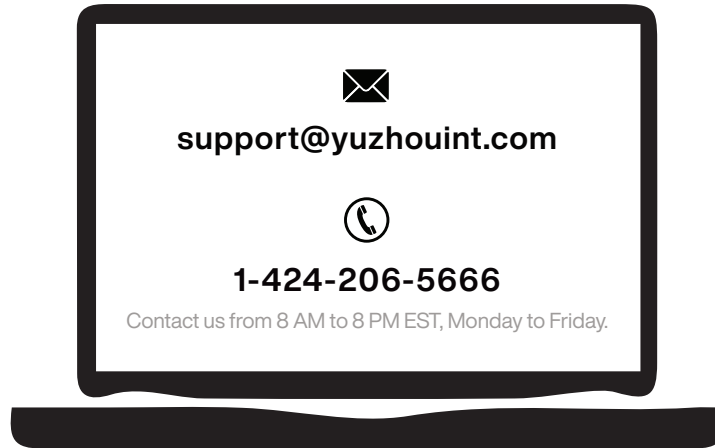

Your satisfaction is our top priority. If you encounter any issues with this product, such as missing or damaged parts, we're here to help. Please retain the original packaging and take photos of the packaging and the product, then contact us as soon as possible.

Warm Tips

1. Carefully read these instructions and keep them for future reference.
2. Check the parts list and confirm everything's there before starting assembly.
3. When assembling, put all parts on a soft, smooth surface like a carpet to avoid scratches.
4. Don't fully tighten screws until all parts are confirmed in place to avoid misalignment.

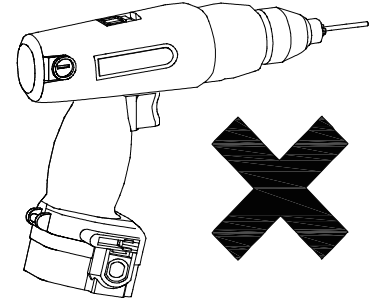
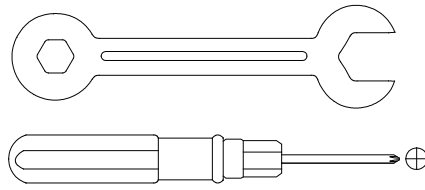
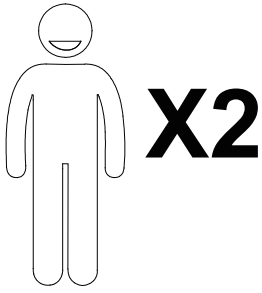

We recommend using hand tools for assembly.

If an electric screwdriver is used, reduce power and torque to avoid damage to the product.

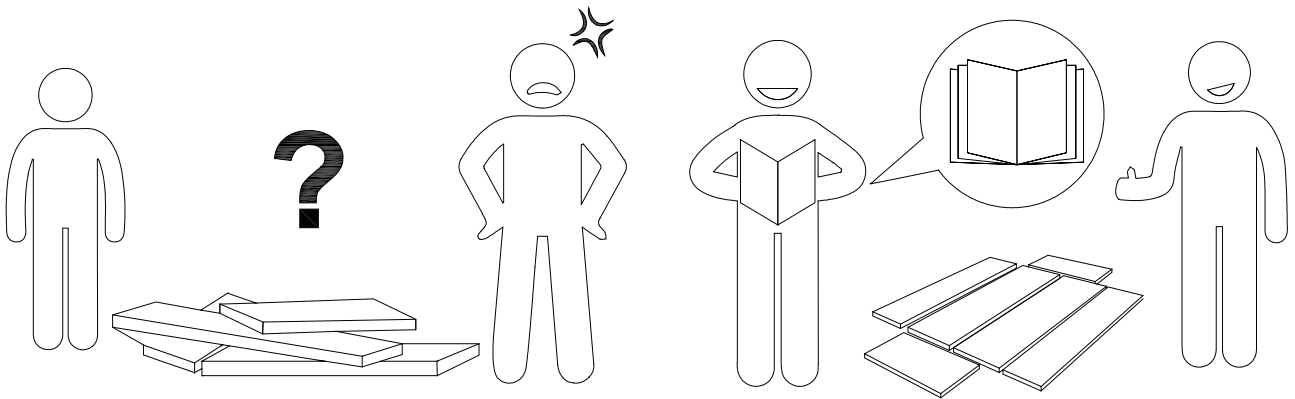

AVOID SCRATCHES

In order to avoid scratching, this furniture should be assembled on a soft surface, such as a rug.

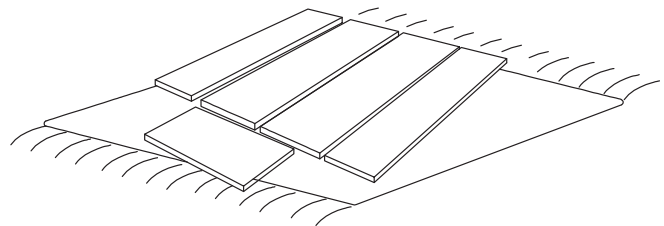
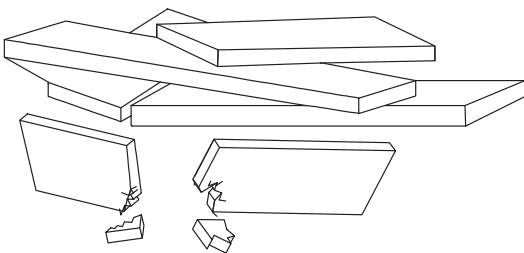

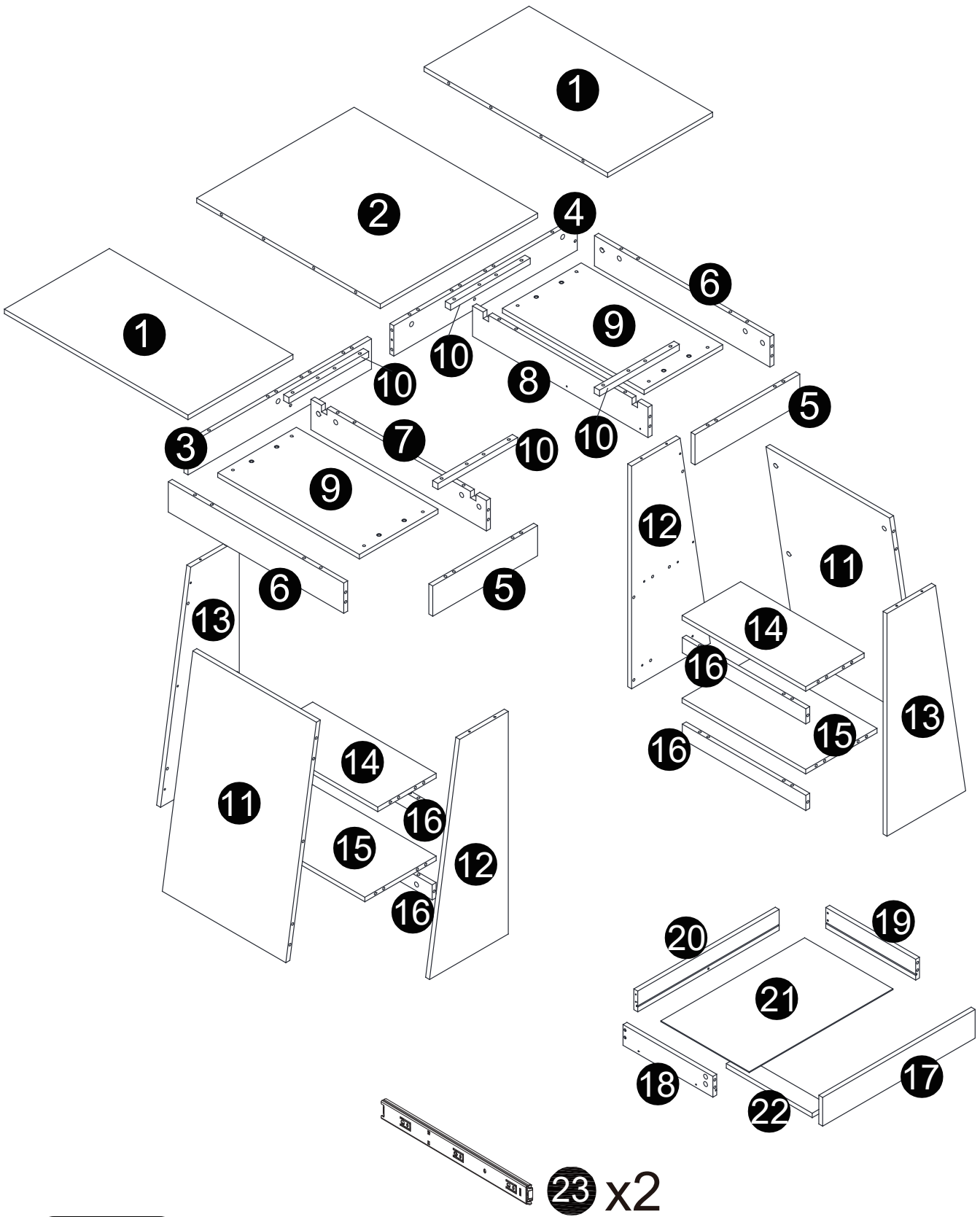





⚠ Caution

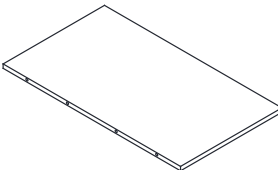
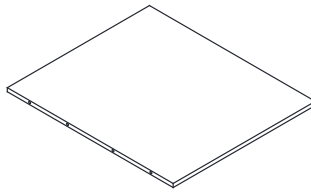
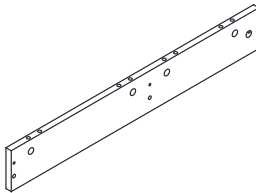
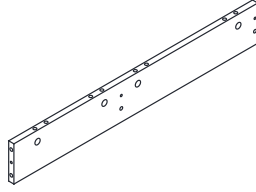
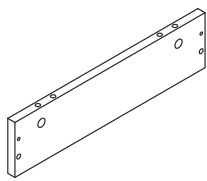
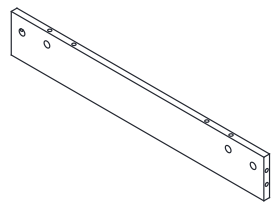
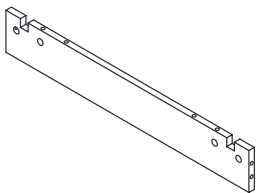
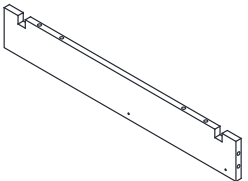
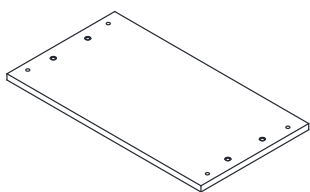
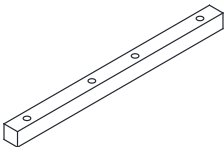
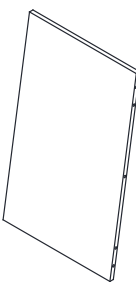

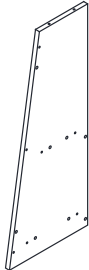
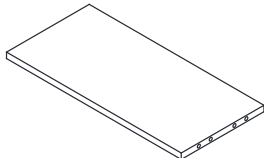
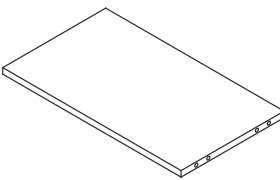
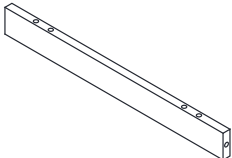
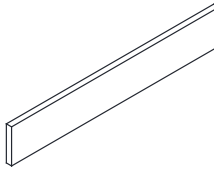
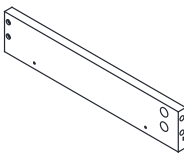
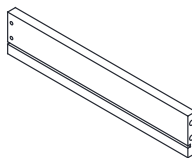
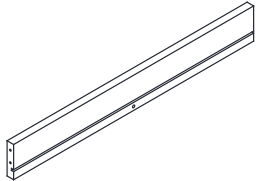
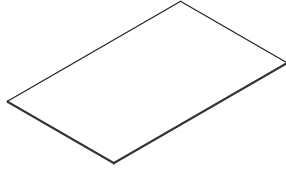
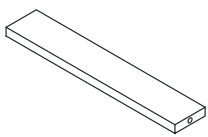
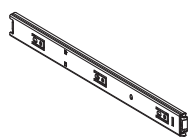
Make sure all parts are included. Most board parts are labeled or stamped on the raw edge. Contact us for a free replacement if you encounter any damaged or missing parts.

Parts List

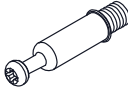
<p>1</p>  <p>2 pcs</p>	<p>2</p>  <p>1 pc</p>	<p>3</p>  <p>1 pc</p>	<p>4</p>  <p>1 pc</p>
<p>5</p>  <p>2 pcs</p>	<p>6</p>  <p>2 pcs</p>	<p>7</p>  <p>1 pc</p>	<p>8</p>  <p>1 pc</p>
<p>9</p>  <p>2 pcs</p>	<p>10</p>  <p>4 pcs</p>	<p>11</p>  <p>2 pcs</p>	<p>12</p>  <p>2 pcs</p>
<p>13</p>  <p>2 pcs</p>	<p>14</p>  <p>2 pcs</p>	<p>15</p>  <p>2 pcs</p>	<p>16</p>  <p>4 pcs</p>
<p>17</p>  <p>1 pc</p>	<p>18</p>  <p>1 pc</p>	<p>19</p>  <p>1 pc</p>	<p>20</p>  <p>1 pc</p>
<p>21</p>  <p>1 pc</p>	<p>22</p>  <p>1 pc</p>	<p>23</p>  <p>2 pcs</p>	

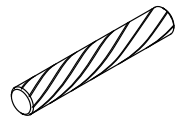
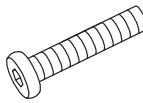
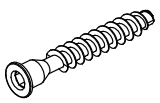
Hardware List

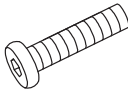
A	B	C	D	E	F
					
M6x35mm	ø15x12mm	ø8x30mm	ø8x40mm	M6x30mm	M7x38mm
69+2pcs	69+2pcs	68+1pcs	10+1pcs	16+1pcs	8+1pcs

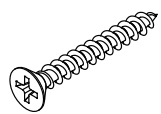
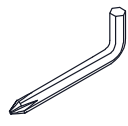
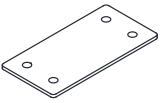
G	H	I	J	K	L
					
M6x25mm		M3.5x12mm	M4x35mm	M4	
8+1pcs	8+1pcs	8+1pcs	5+1 pcs	1pc	1pc

M

M6x12mm
4+1pcs

Installation of Cams and Pins

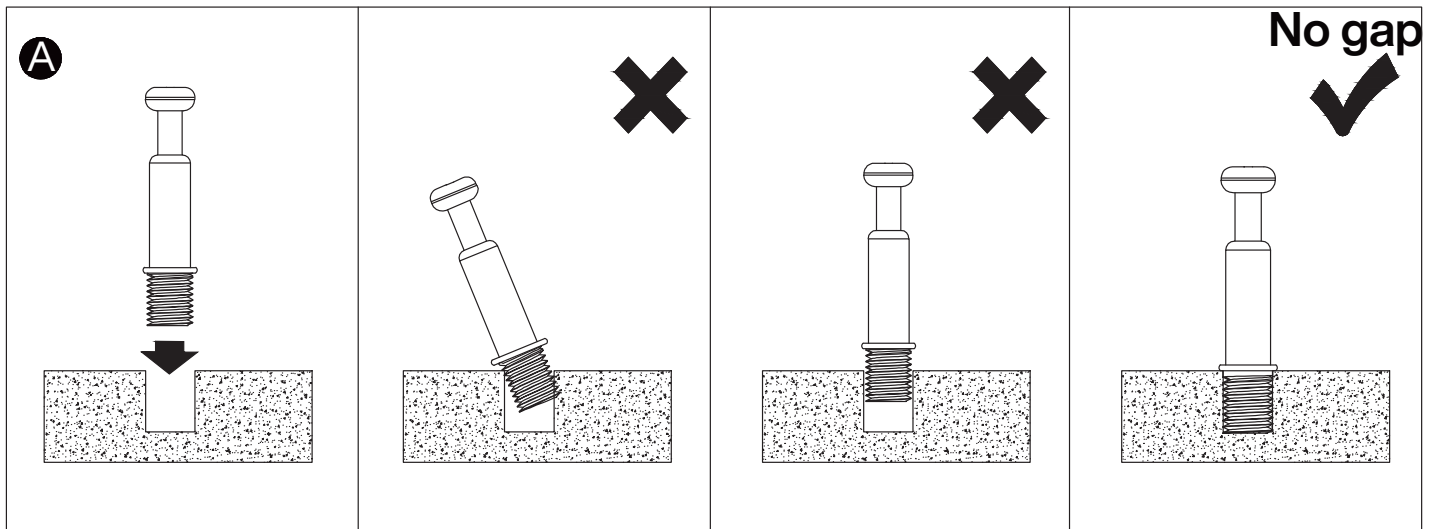
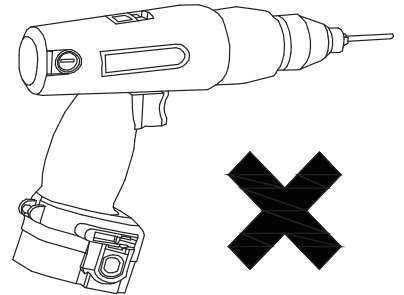
Read each step carefully before starting. Each step of instruction should be performed in the correct order. If these steps are not followed in sequence, assembly difficulties may occur.

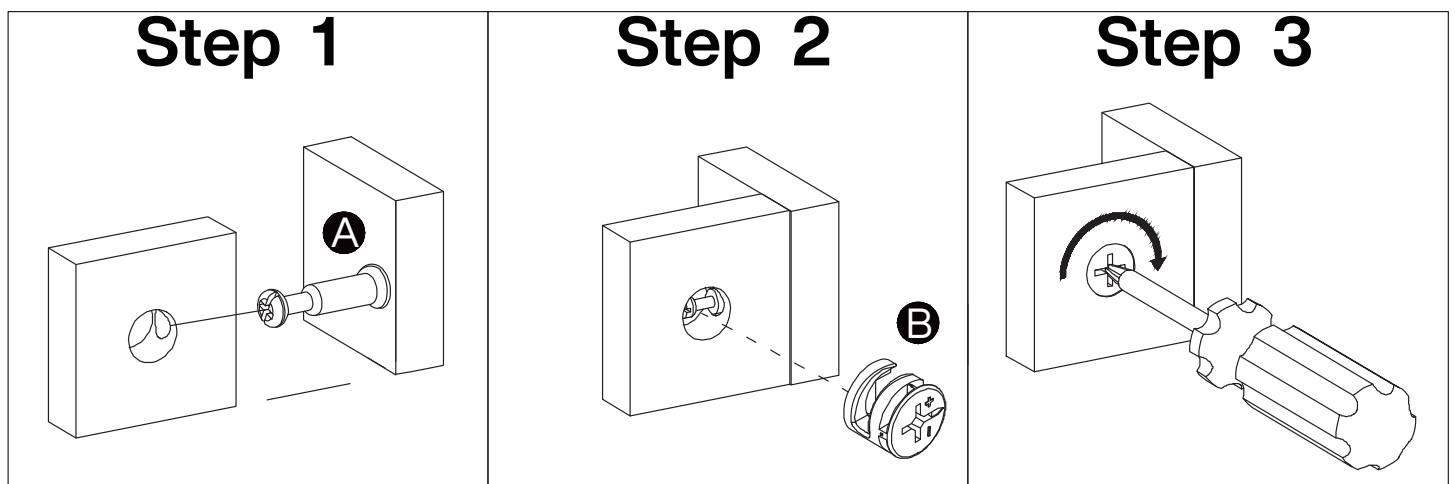

Screw the pin into the hole. Set the cams correctly by aligning the head of the cams with the lock pins. Lock the cam by turning the cam head with a screwdriver until it is tightened. Please do not use an electric screwdriver to assemble the unit.



Please split component "23" into "23-1" and "23-2" before assembling the slide and then proceed to the next step of assembly

Step 1

Pull apart component "23" to each side, and then gently push up the lever of component "23-2"

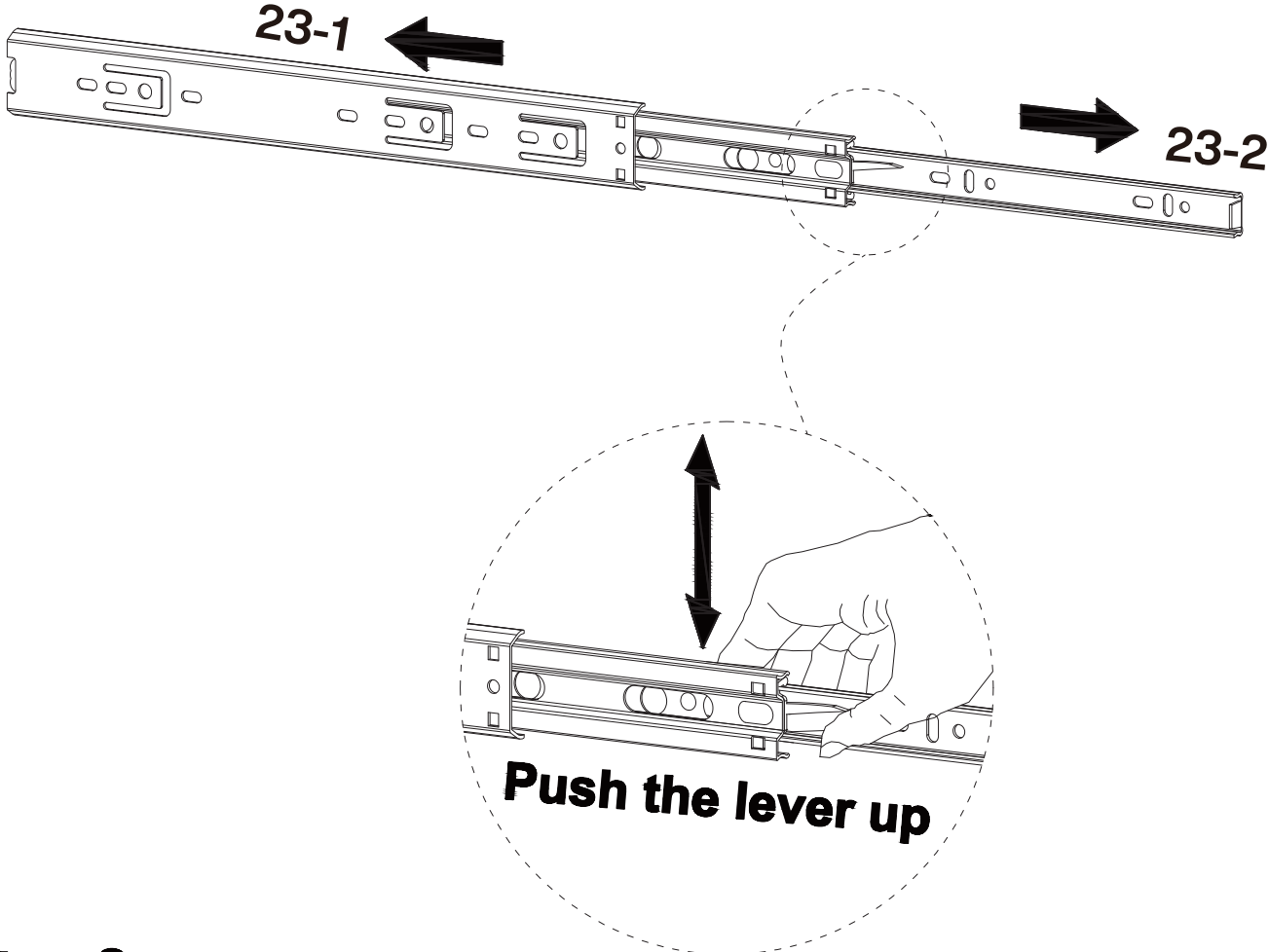

Step 2 Split component "23-1" and "23-2"

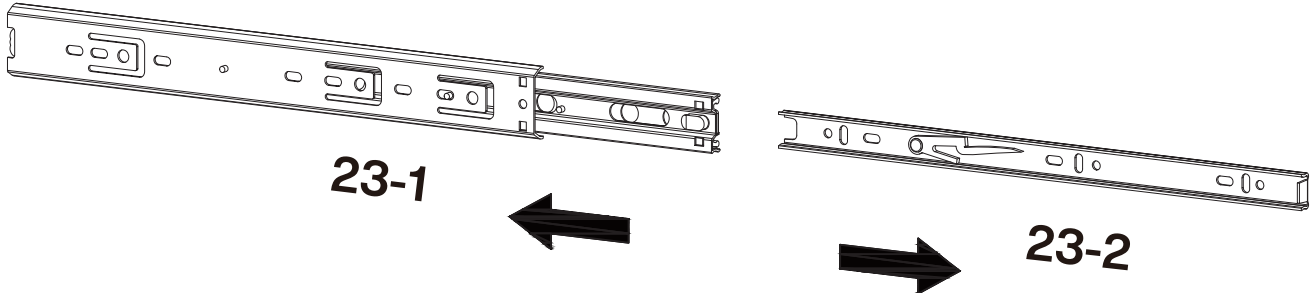



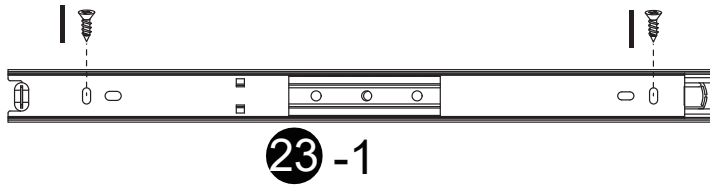

1

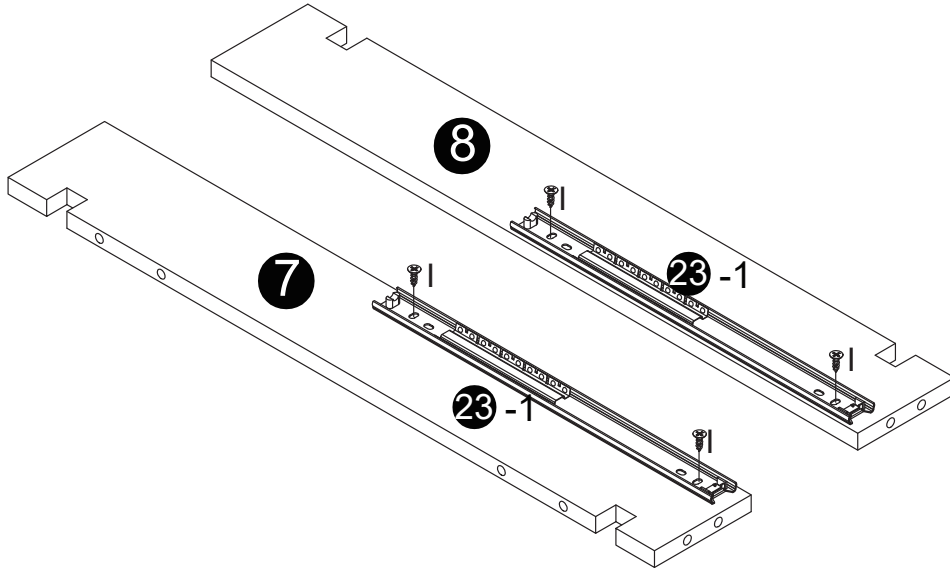

I

Ø3.5x12mm
4 pcs



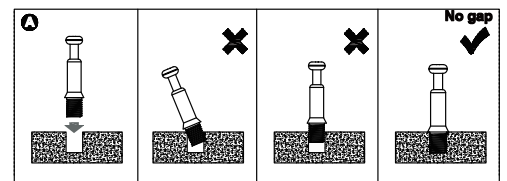
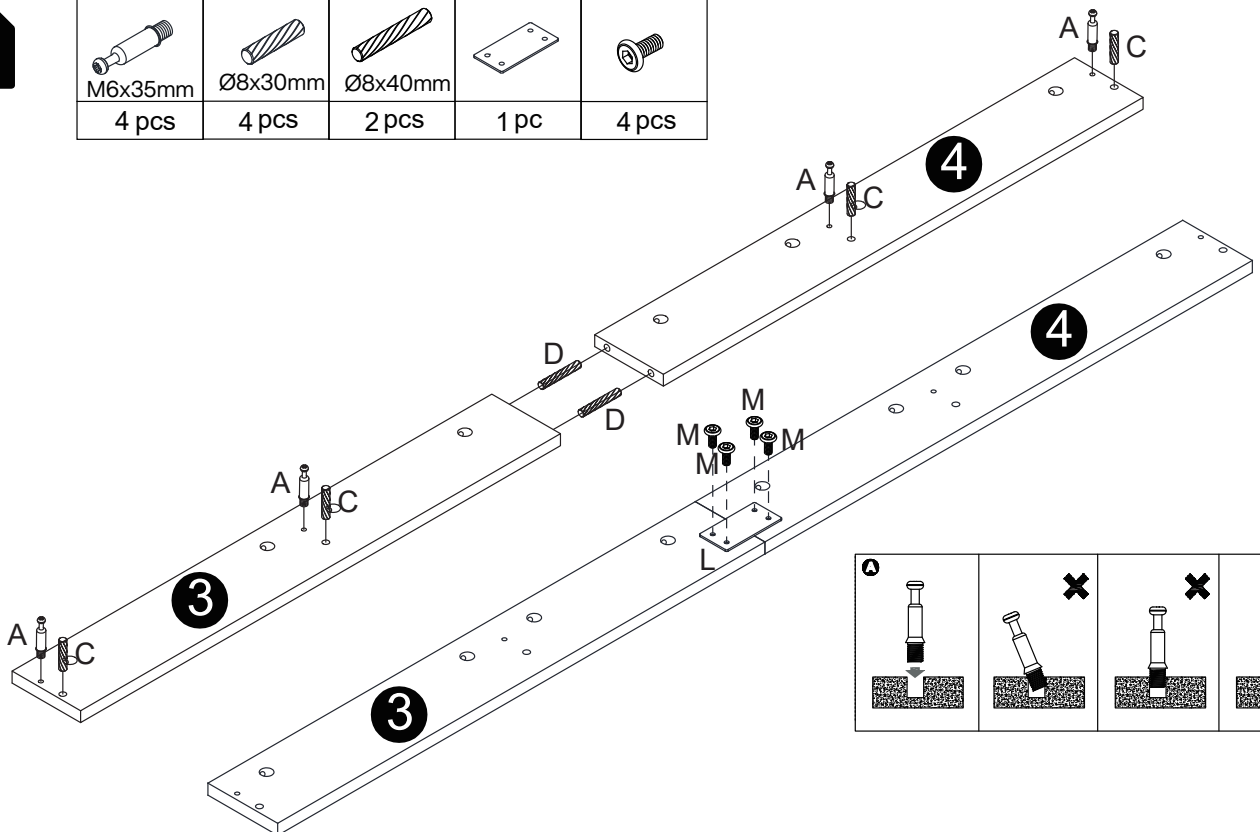

2

A	C	D	L	M
				
M6x35mm 4 pcs	Ø8x30mm 4 pcs	Ø8x40mm 2 pcs	1 pc	4 pcs

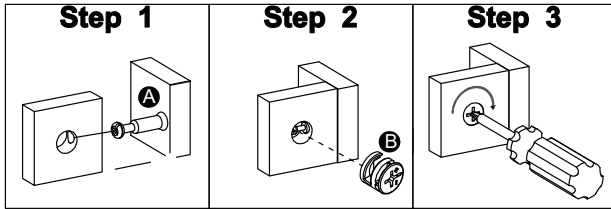

3



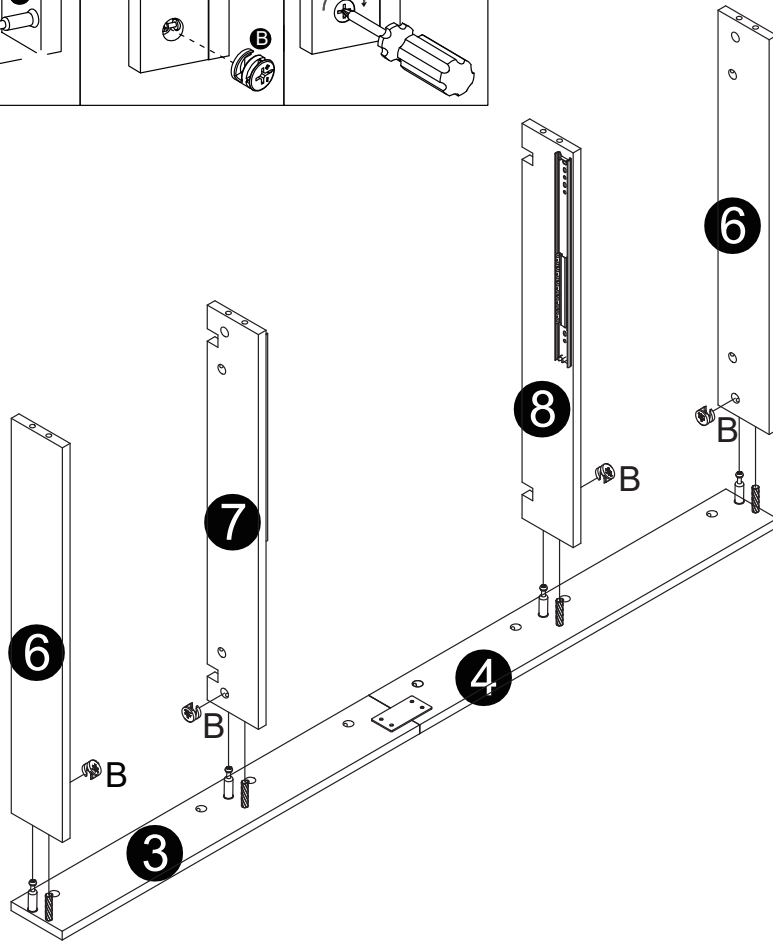

B

Ø15x12mm
4 pcs

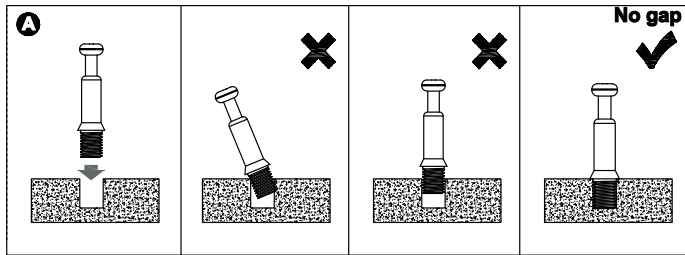



4

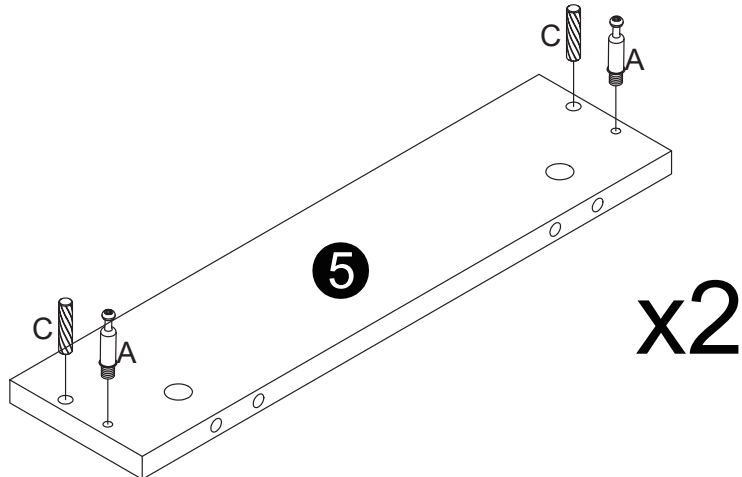

A	C
	
M6x35mm	Ø8x30mm
4 pcs	4 pcs

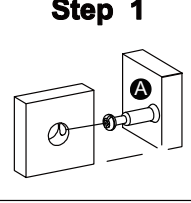
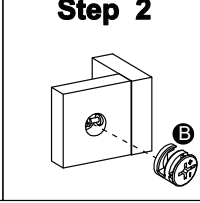
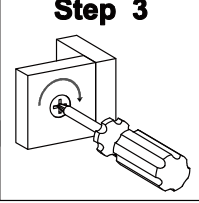

5

Step 1 	Step 2 	Step 3 	B  Ø15x12mm 4 pcs
--	---	--	--

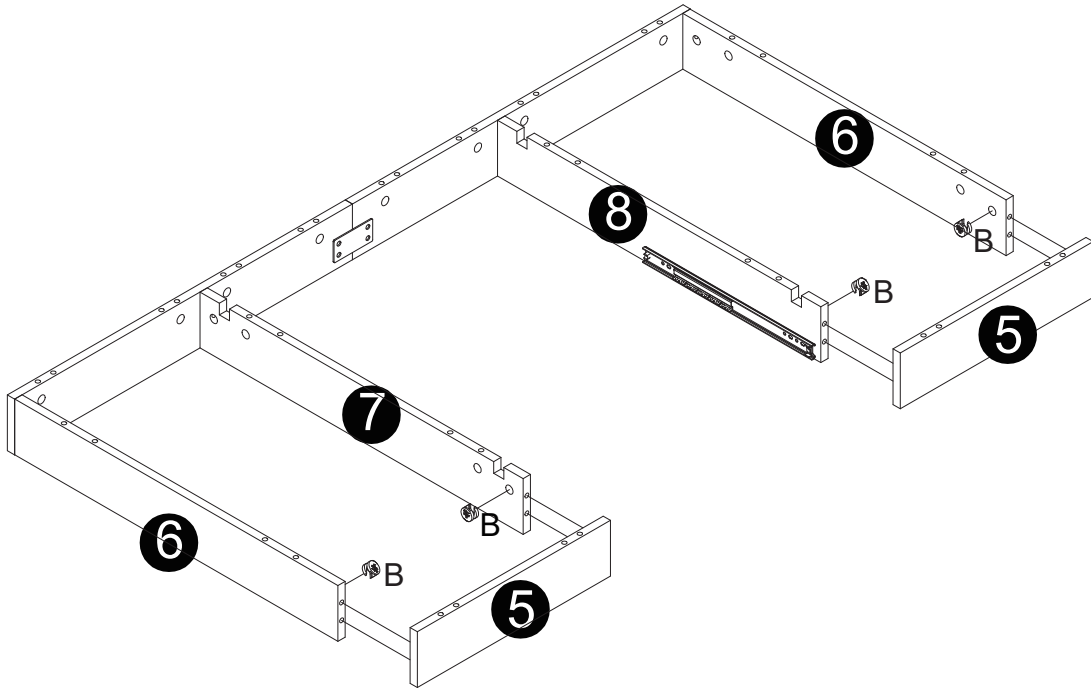

6

D

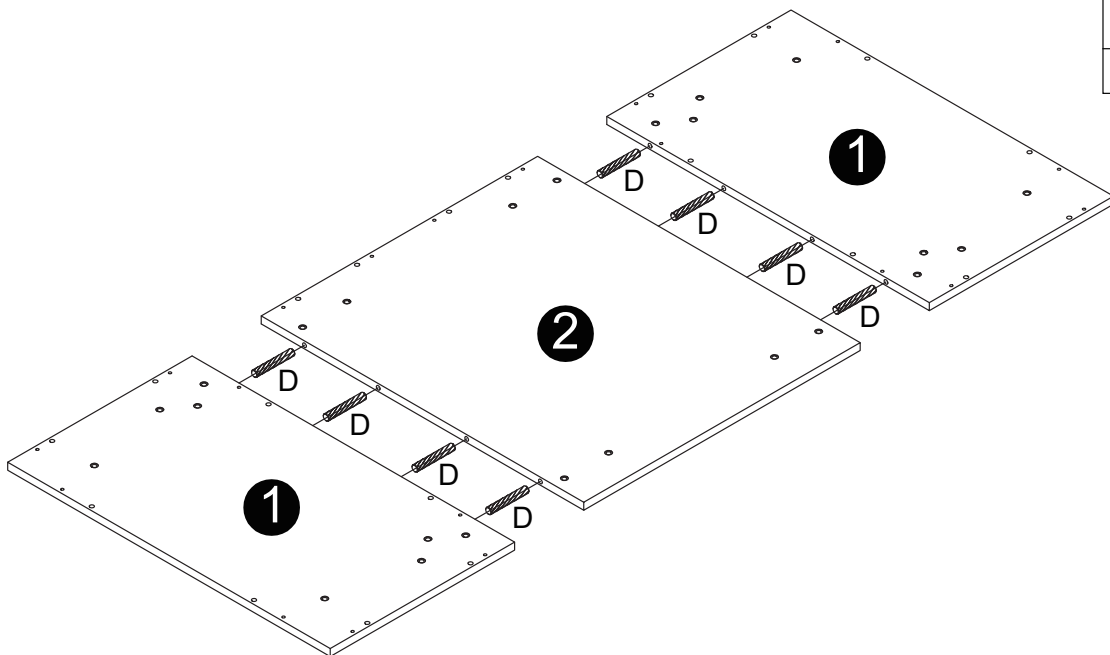
8 pcs



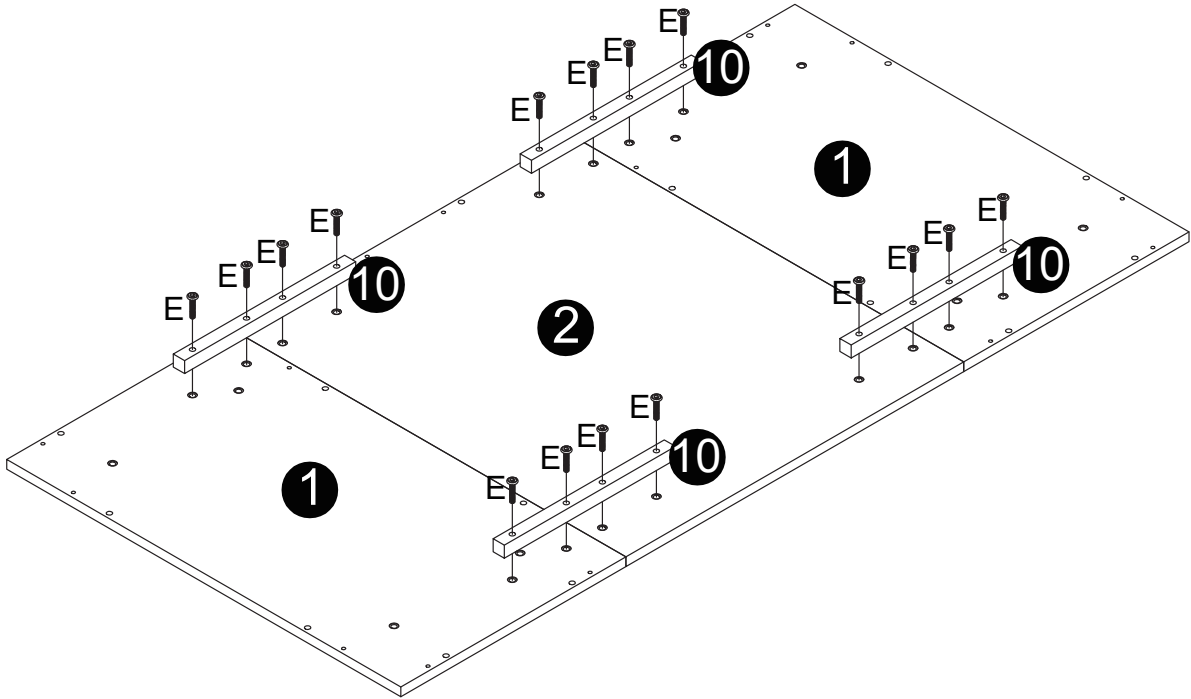

7

E

M6x30mm
16pcs

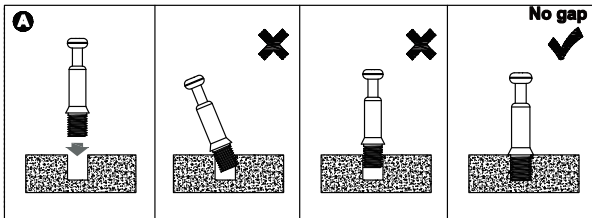

8

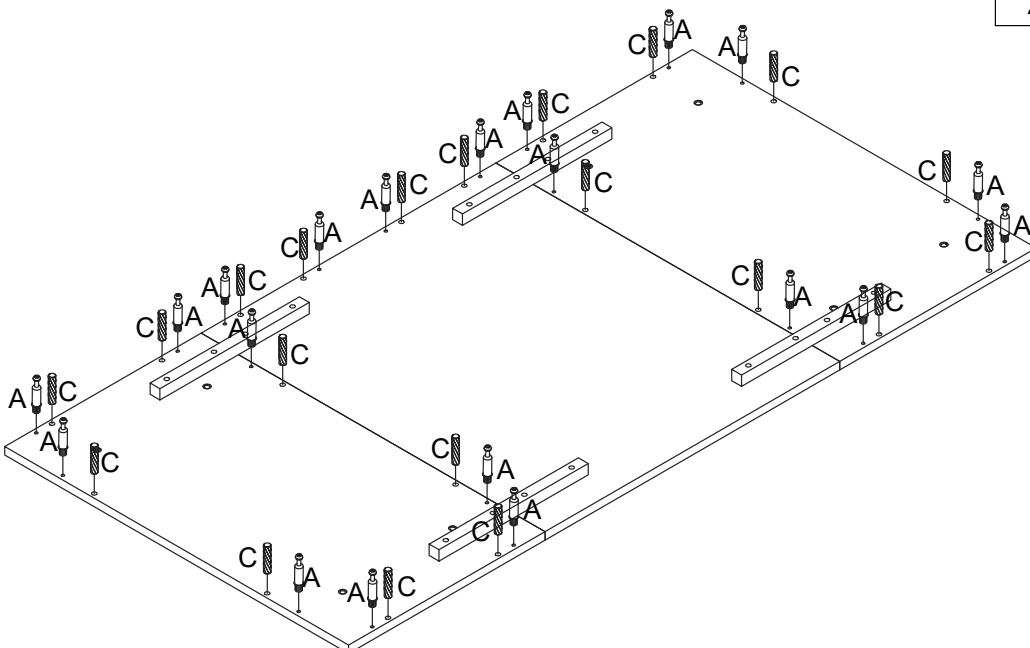

A	C
	
M6x35mm	Ø8x30mm
20pcs	20pcs



9

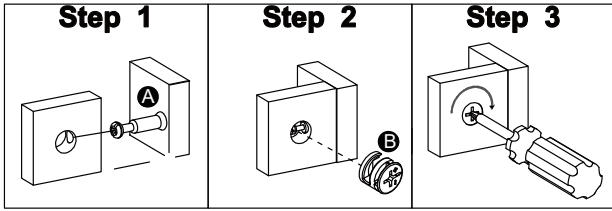

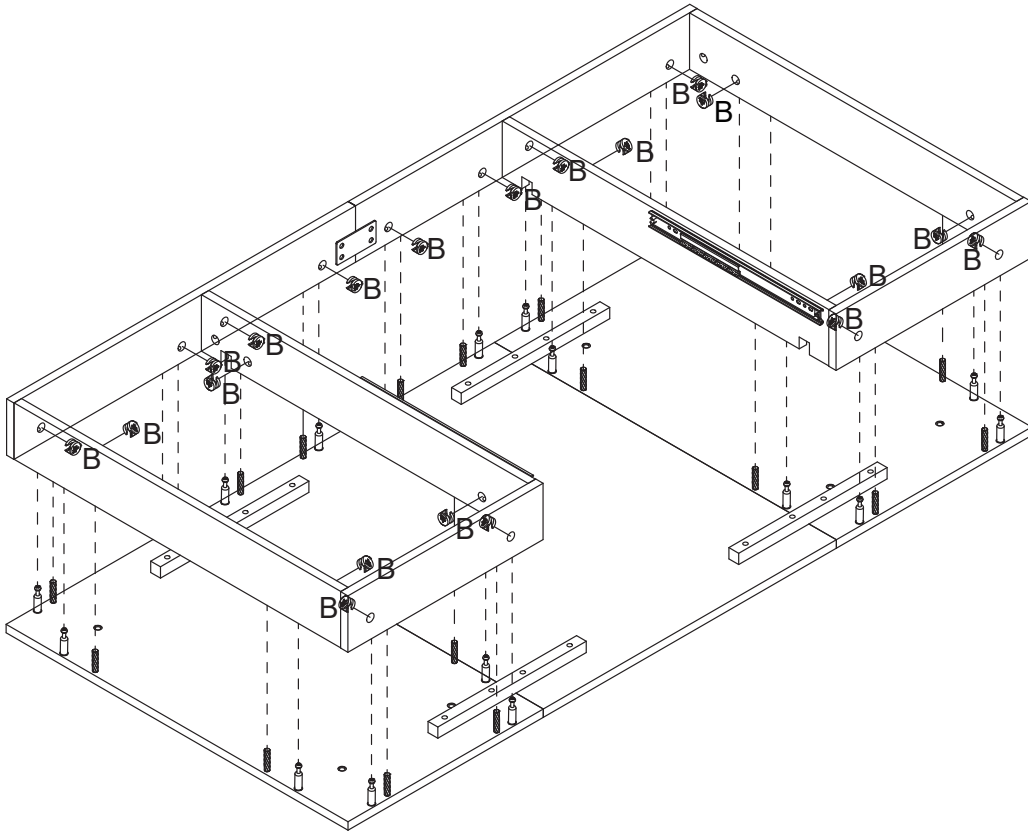

B

Ø15x12mm
20 pcs

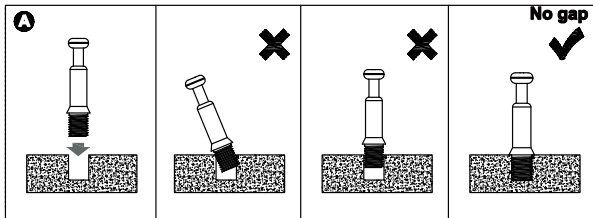

10

x2



A	C
	
M6x35mm	Ø8x30mm
8 pcs	8 pcs

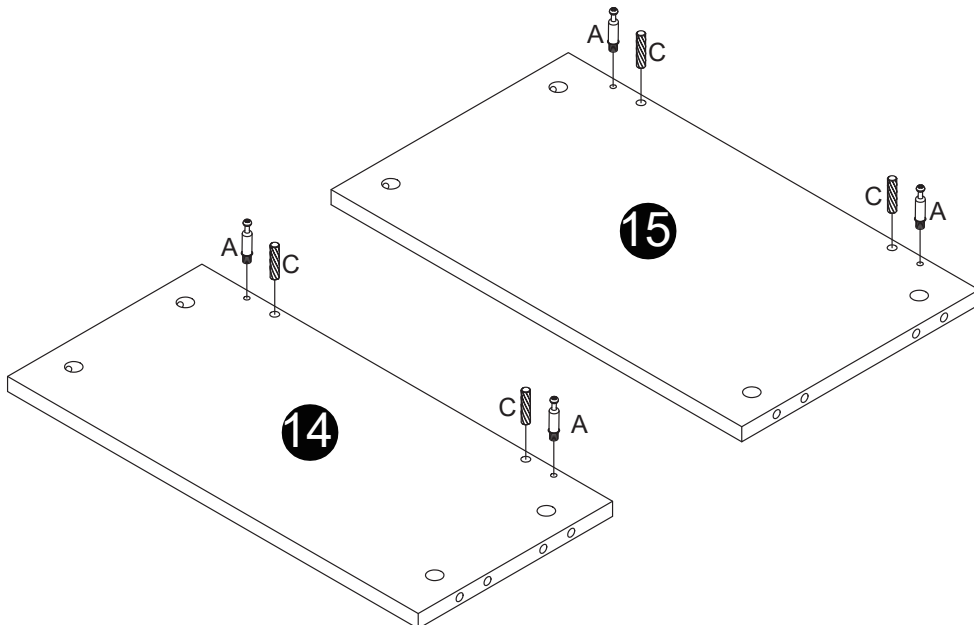

11

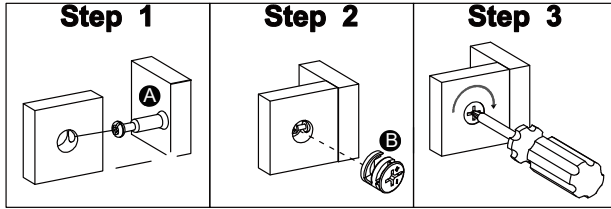

B
Ø15x12mm
8 pcs

x2

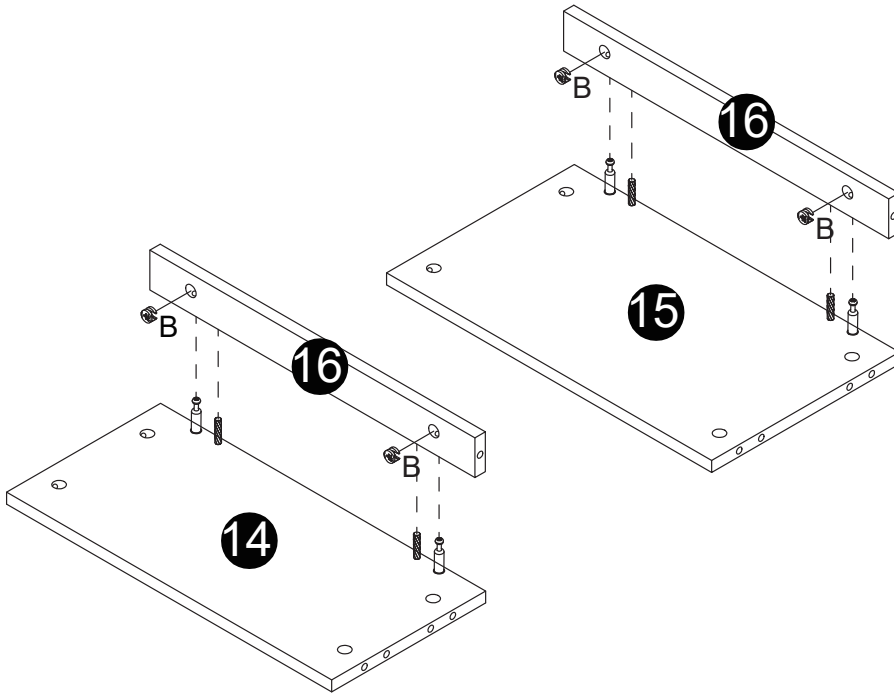

12

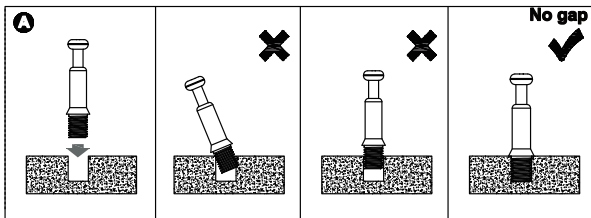

A	C
M6x35mm	Ø8x30mm
28 pcs	32 pcs

x2

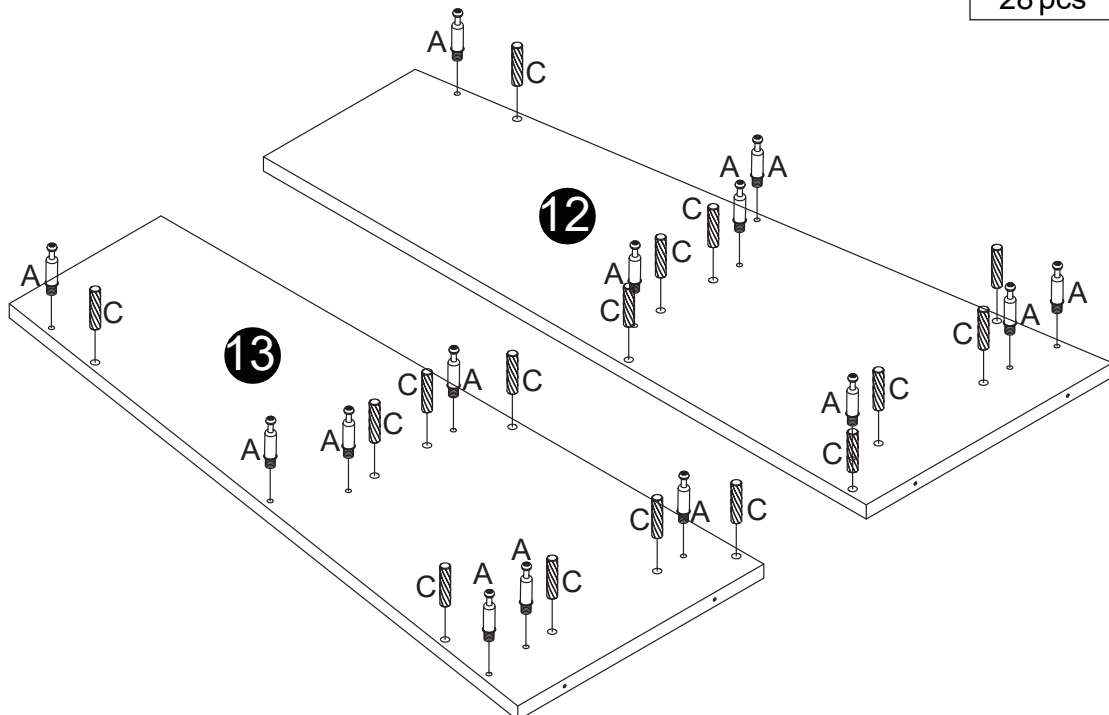

13

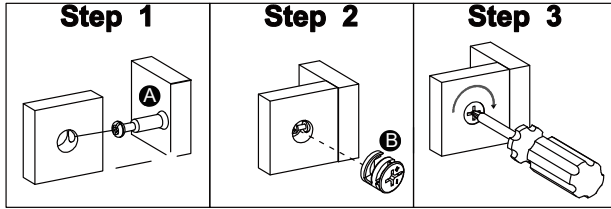

B
Ø15x12mm
6 pcs

x2

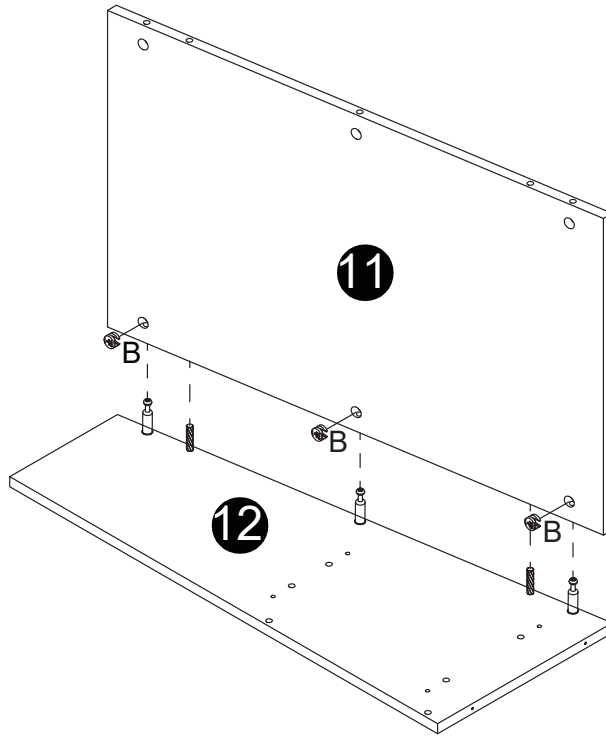

14

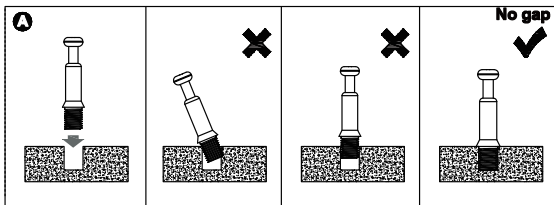

B
Ø15x12mm
8 pcs

x2

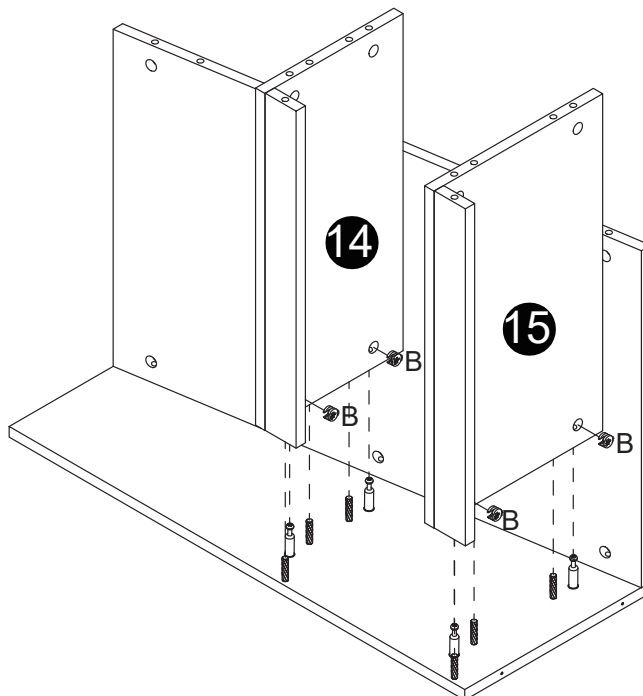

15

x2

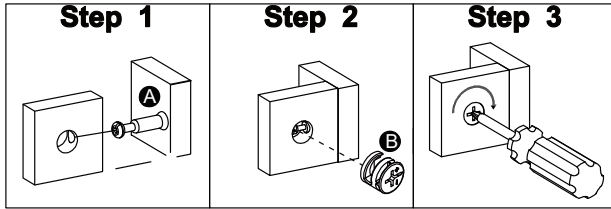

B
Ø15x12mm
14 pcs

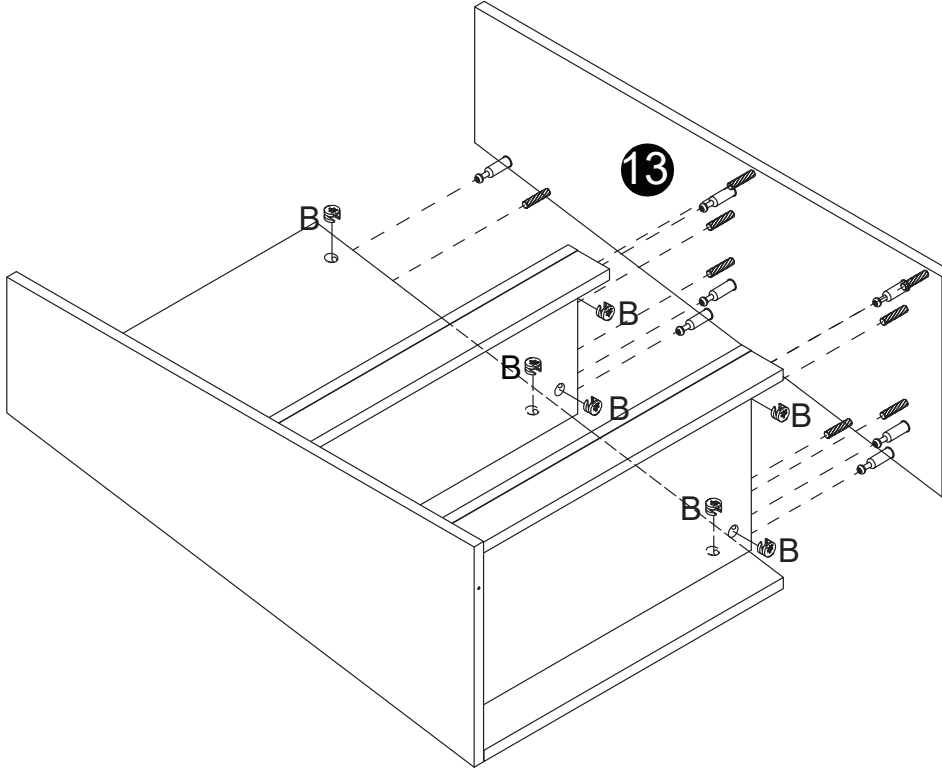

16

x2

H
8 pcs

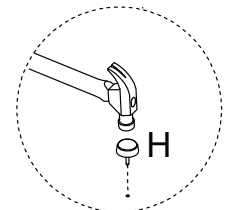
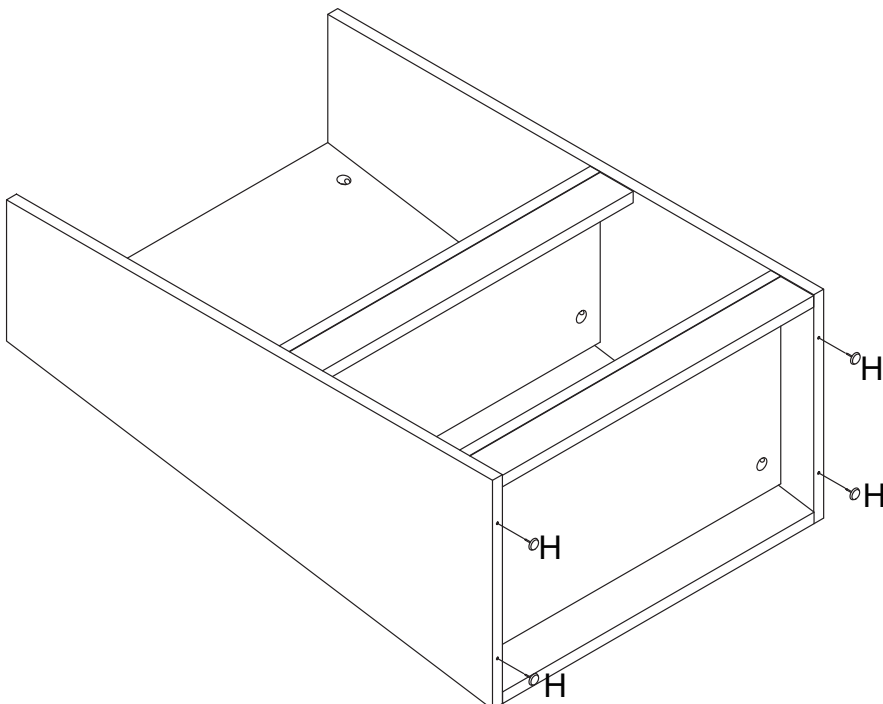

Caution! Tap lightly

17

x2

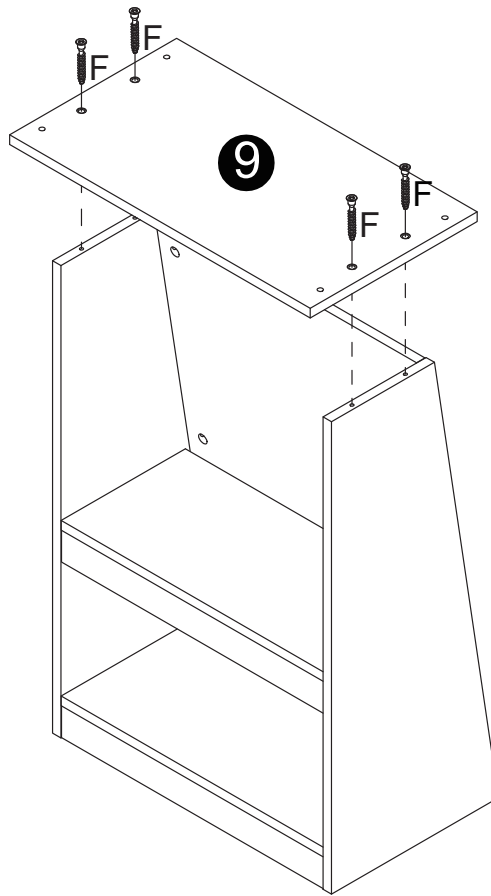

F

M7x38mm
8 pcs

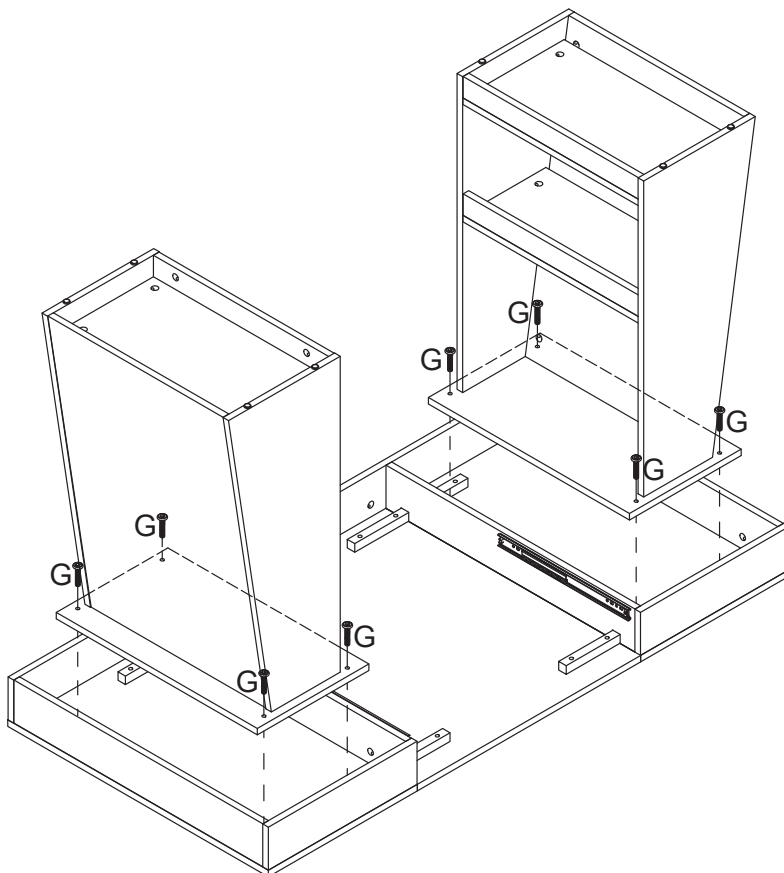
18



G

M6x25mm
8 pcs

19

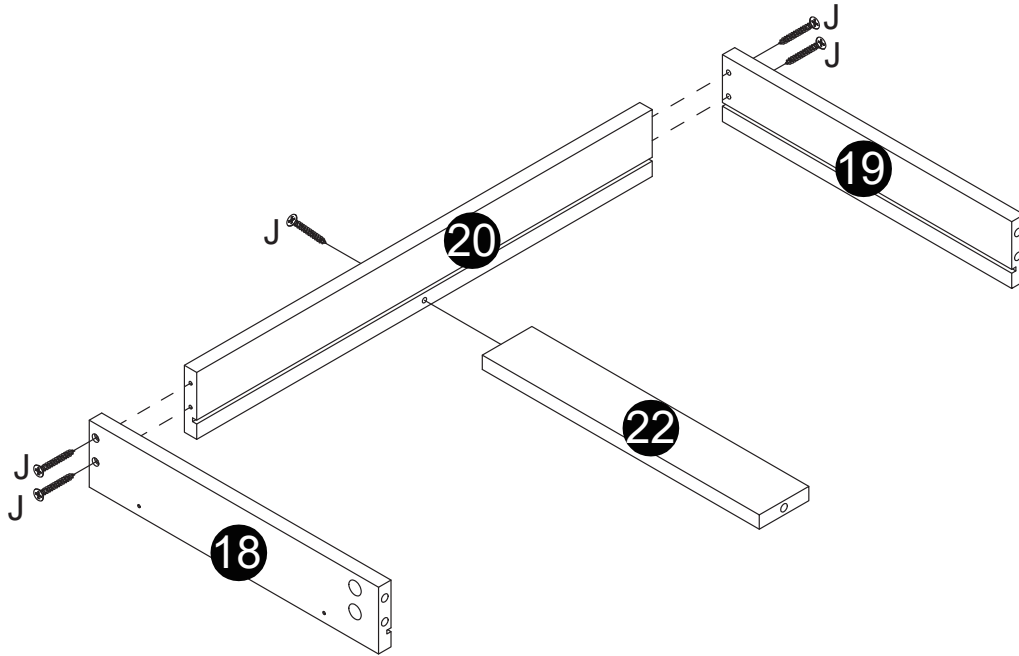
J

M4x35mm
5 pcs

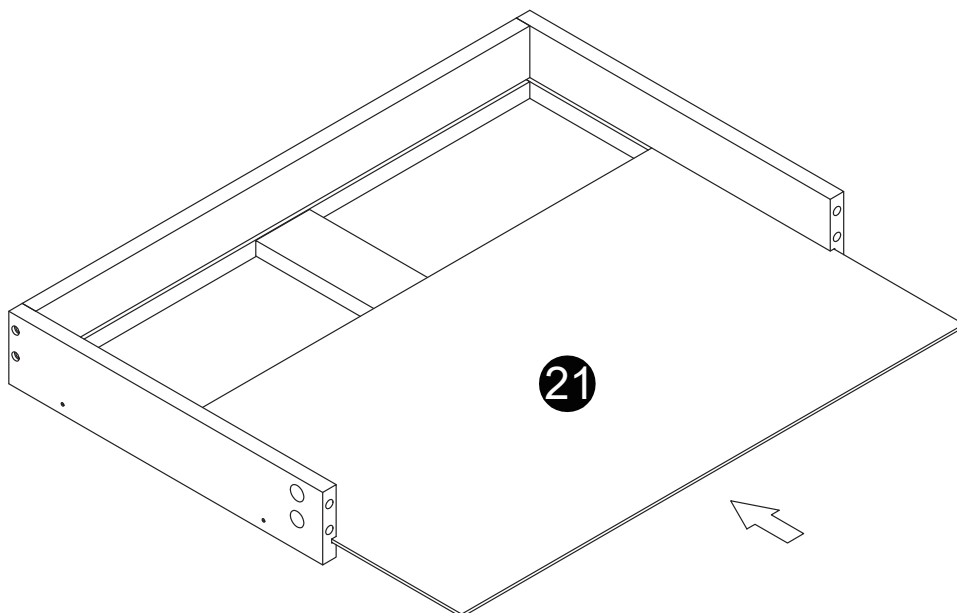



20

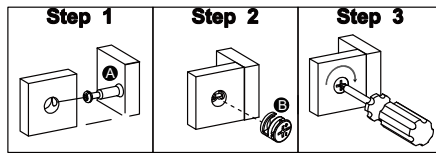
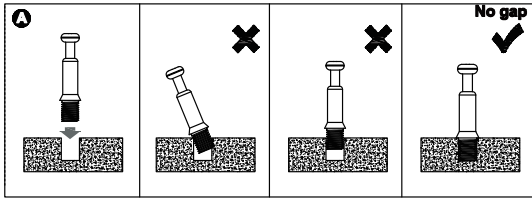

21



A	B
	
M6x35mm	Ø15x12mm
5 pcs	5 pcs

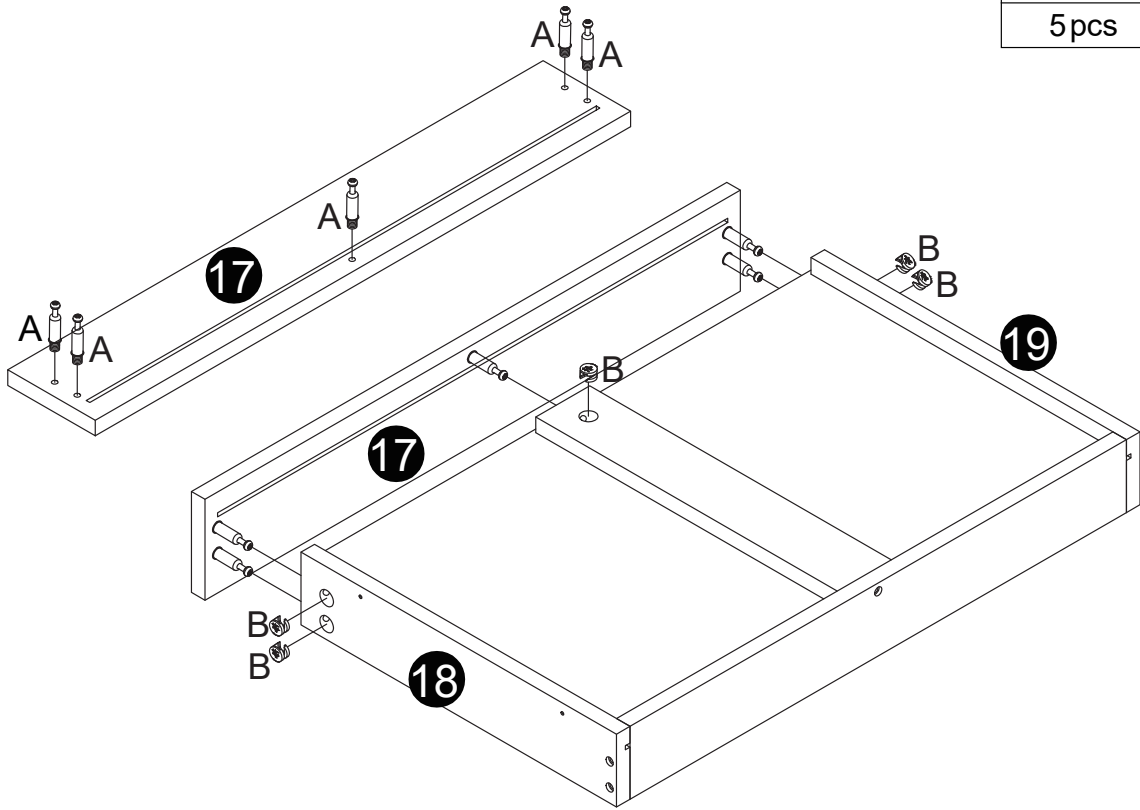

22

I

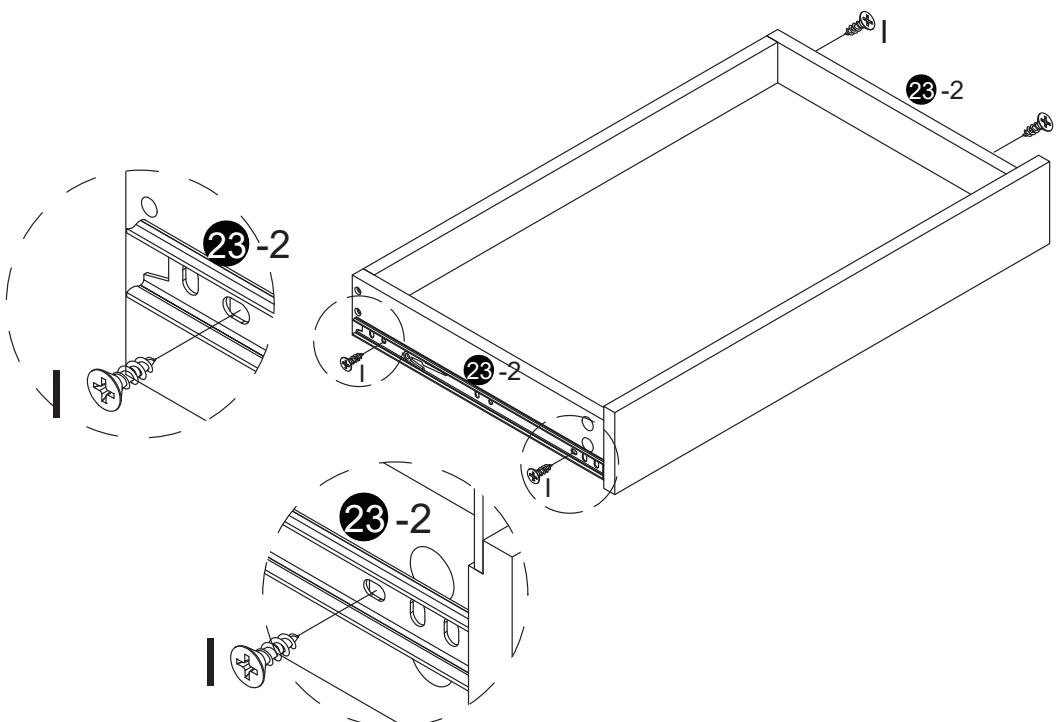
3.5x12mm
4 pcs

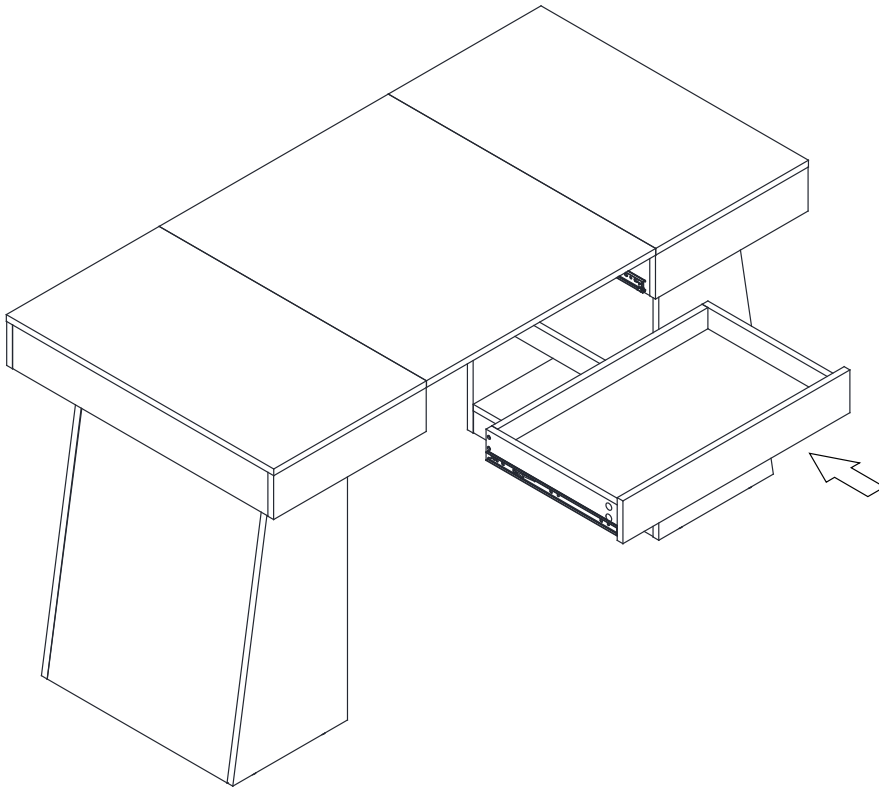

23

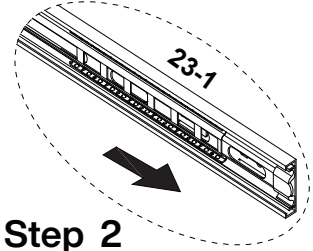

Step 1



Step 2

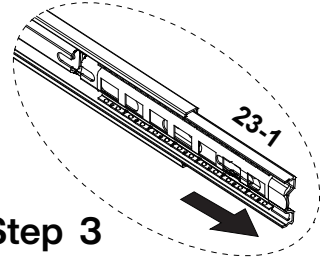

Step 3

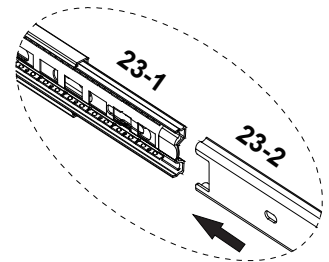

Before installation, slide the inner iron pieces of #23-1 to the outermost side. Then align it with #23-2 and gently push it inward to complete the slide installation.

24

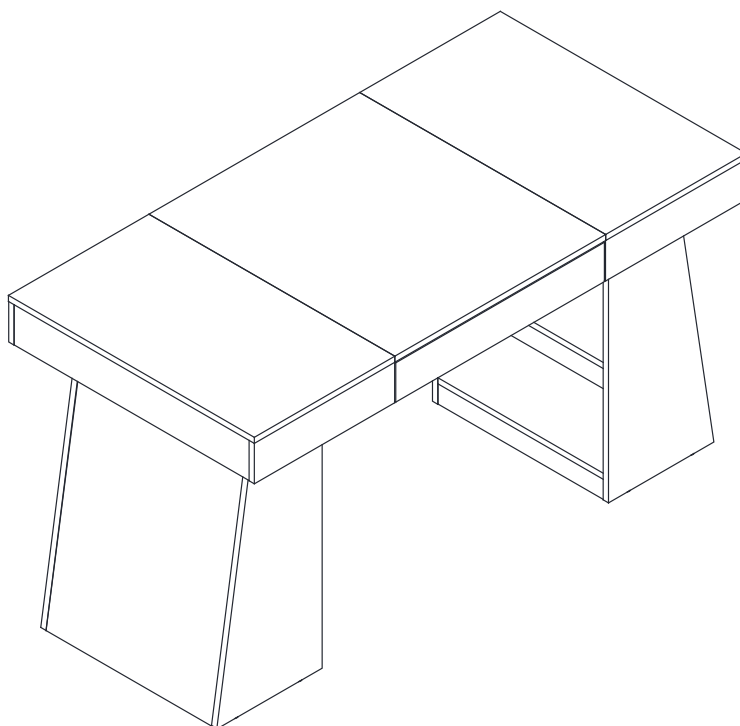

Thank you for your support!

