

Air Gap Kit With Air Gap Cap
K1037

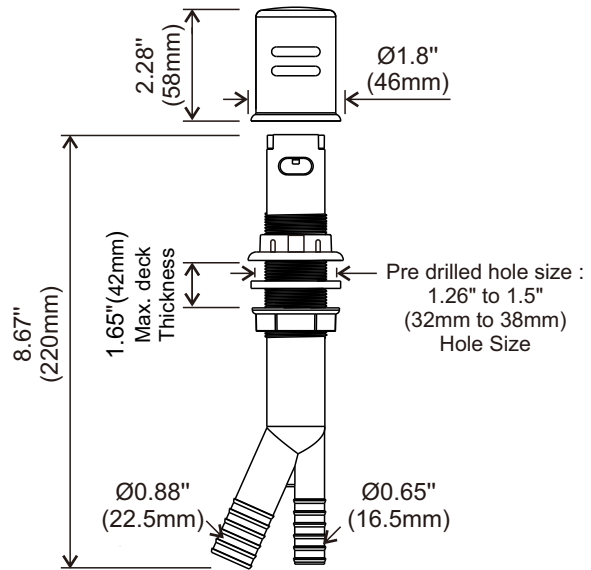
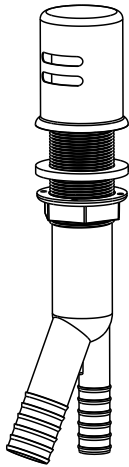

unit:inch (mm)

- | | | |
|---|---|---|
| <p>1</p> <p>Cap
Collar
Cap Body</p> <p>1. Remove cap and collar from Cap body.</p> | <p>2</p> <p>Ø7/8"
Ø5/8"
Screwdriver (not with)
Hose (not with)</p> <p>2. Attach 5/8" dishwasher drain hose to 5/8" leg .
Secure with hose clamp.</p> | <p>3</p> <p>Screwdriver (not with)
Hose (not with)</p> <p>3. Attach 7/8" garbage disposal hose or side inlet sink trap drain hose to 7/8" leg.
Secure with hose Clamp.</p> |
| <p>4</p> <p>4. Thread the Air Cap from below through the countertop.</p> | <p>5</p> <p>Collar</p> <p>5. Tighten the nut and collar. Please note that the exposed height of the drain should not exceed 56mm (2.2 ").</p> | <p>6</p> <p>Cap</p> <p>6. Adjust the cap of the exhaust hole on the cover, place cap over the body collar.</p> |