

ASSEMBLY INSTRUCTION FOR ACME FURNITURE

Thank you for purchasing the quality product. Be sure to check all packing material carefully for small parts which may have come loose inside the carton during shipment. Separate, identify and count all parts and metal hardware. Compare with all parts list to be sure all parts are present. If any part(s) are missing or damaged, please contact your local furniture dealer. For efficient and speedy service, please indicate the model number and code letter of part(s) needed.

*****Do not fully tighten screws until fully assembled*****

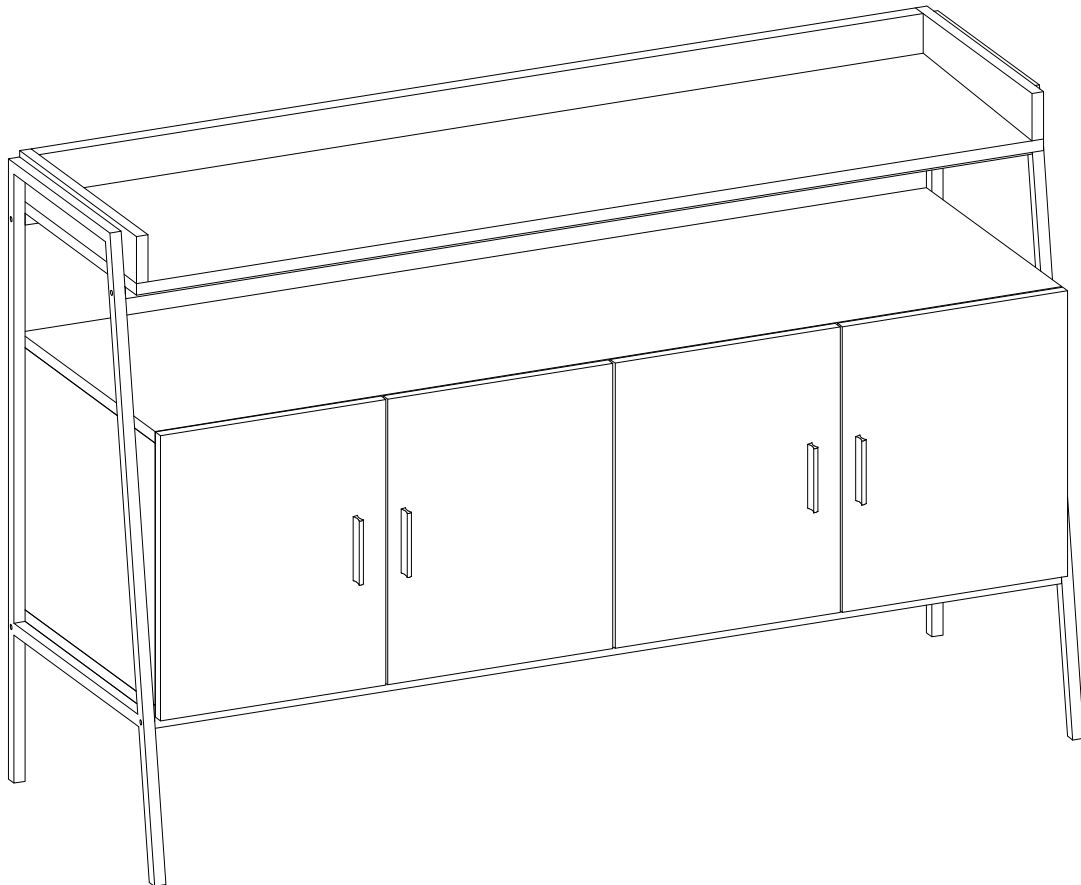

Attention:

*** Some number parts listed on the instruction sheet may not be in parts bag as they may already be assembled. Carefully check parts and packing materials prior to ordering replacements.

General Assembly Guidelines

- I. Ensure that all parts and hardware are available before beginning assembly.
- II. Follow each step carefully to ensure the proper assembly of this product.
- III. Two people are recommended for ease in the assembly of this product.
- IV. The three main types of hardware used to assemble this product are: wood dowels, screws and bolts.
- V. The provided glue is to secure wood dowels in place. When first inserting dowels, locate the appropriate hole for the dowel, place a small amount of glue in the hole and insert the dowel. Wipe away excess glue immediately.

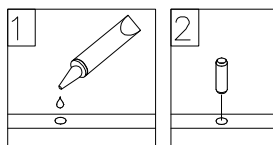

In future assembly steps when dowels are necessary to attach assembly parts together, place a small amount of glue on the end of the dowel before attaching parts together. Wipe away excess glue immediately.

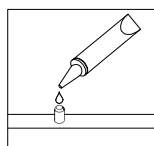

- VI. A Phillips head screwdriver is required for the assembly of this product.

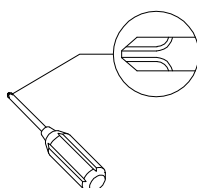

- VII. Power tools should not be used to assemble this product.

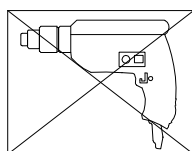

- VIII. Drill may be needed for securing product to wall.

- IX. Concealed hinges are three-way adjustable.

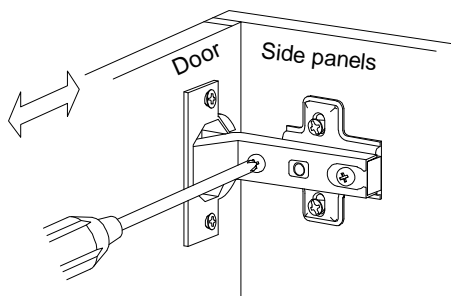

Horizontal
by screw adjustment

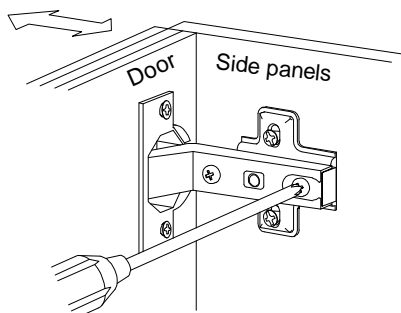

In-and-Out
by loosening the hinge-arm
mounting screw or via cam
adjustment

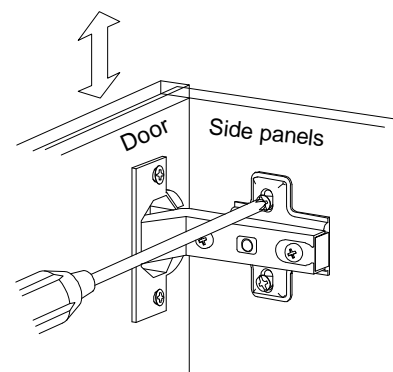





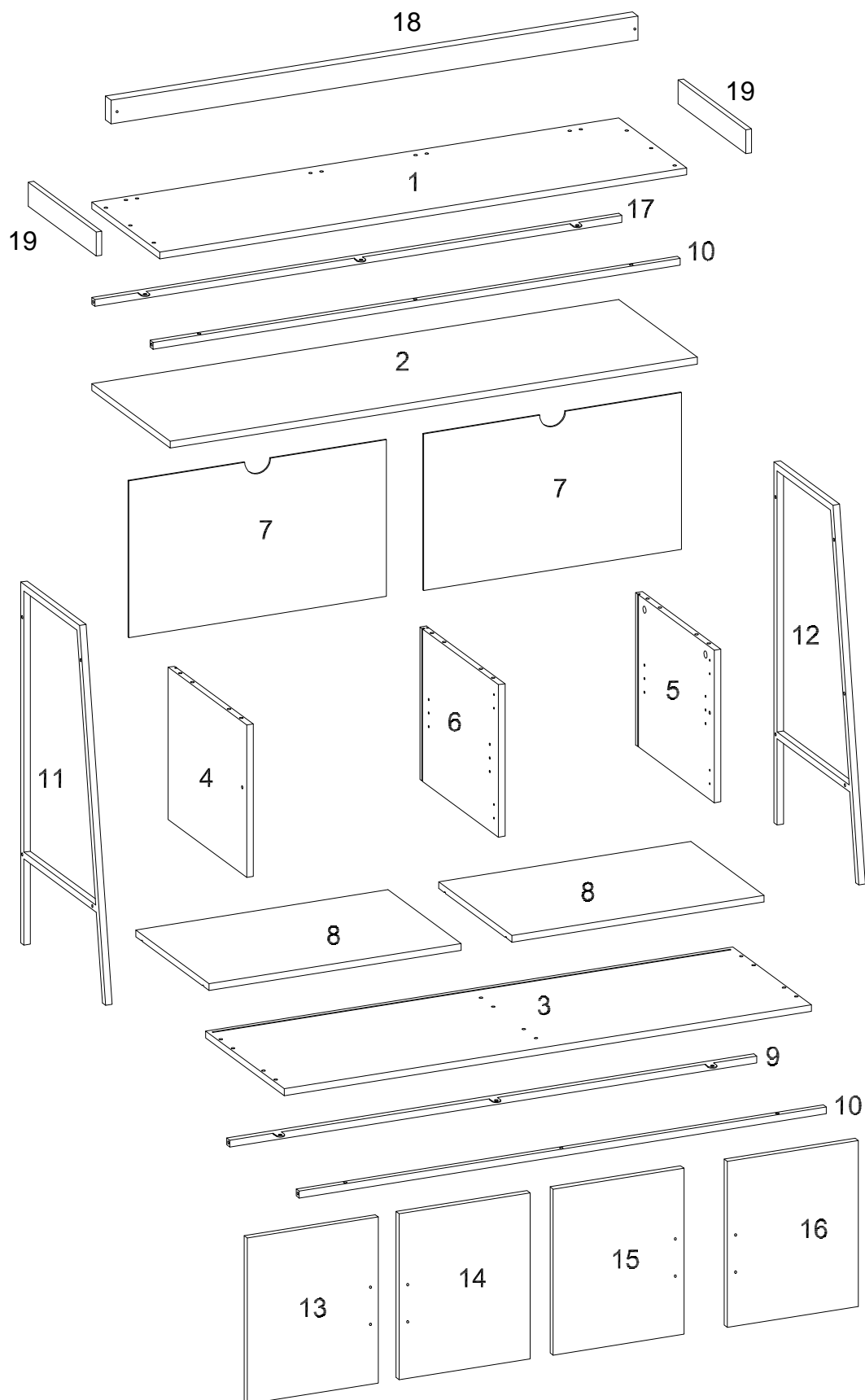

















Vertical
Via slots in the mounting
plate or via cam adjustment

Parts List



Hardware List

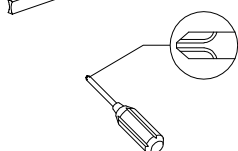

A		Ø8x30mm	Wooden dowel	18 pcs
B		Ø6x35mm	Cam bolt	6 pcs
C		Ø15x11mm	Cam lock	6 pcs
D		Ø30mm	Sticker	6 pcs
E		Ø6x50mm	Screw	6 pcs
F		Ø1/4x12mm	Bolt	8 pcs
G		Ø1/4x25mm	Bolt	16 pcs
H			Plastic wedge	8 pcs
I		Ø4x16mm	Screw	8 pcs
J		Ø3x17mm	Screw	8 pcs
K			Hinge	4 pcs
L			Hinge	4 pcs
M		Ø3.5x14mm	Screw	32 pcs
N		4mm	Hex Key	1 pc
O		Ø3.5x35mm	Screw	10 pcs
P		Ø8x5x16mm	Shelf support pin	8 pcs
Q			Glue tube	1 pc
R			L shape Bracket	2 pcs
S		Ø4x30mm	Screw	2 pcs
T			Anchor	2 pcs
U			Washer	2 pcs
V			Handle	4 pcs



Philips head screwdriver required for assembly
(not included)

*The hardware quantities listed above are required for proper assembly.
Some extra hardware may also have been included.*

Step 1

A x 6	O x 10
	
Ø8x30mm	Ø3.5x35mm

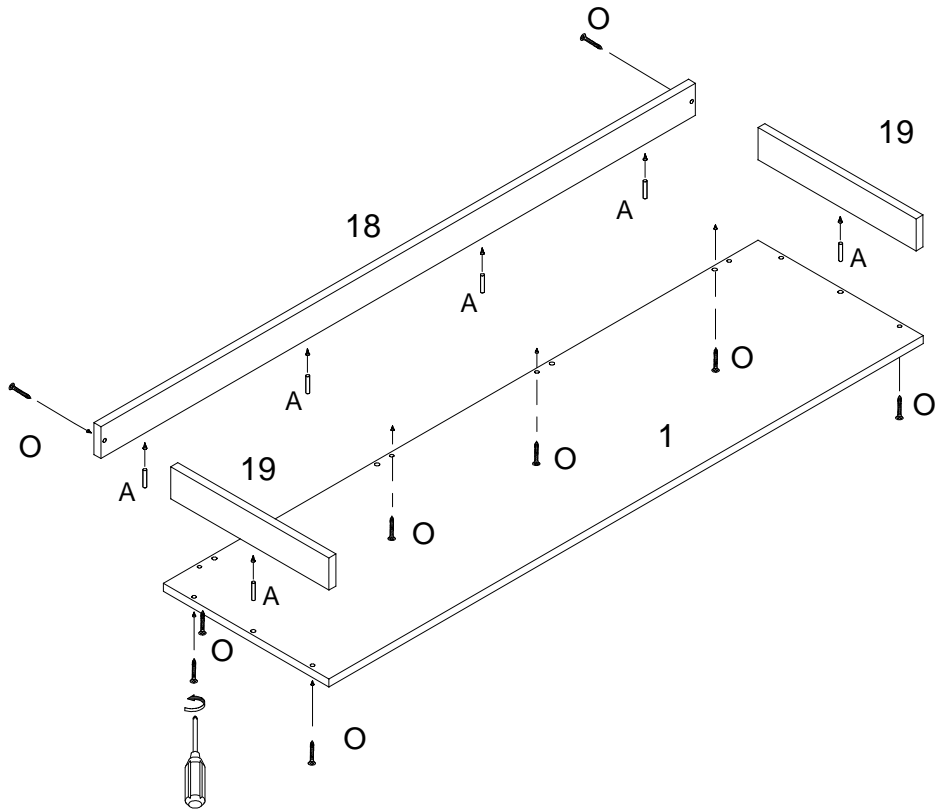

Step 2

B x 6

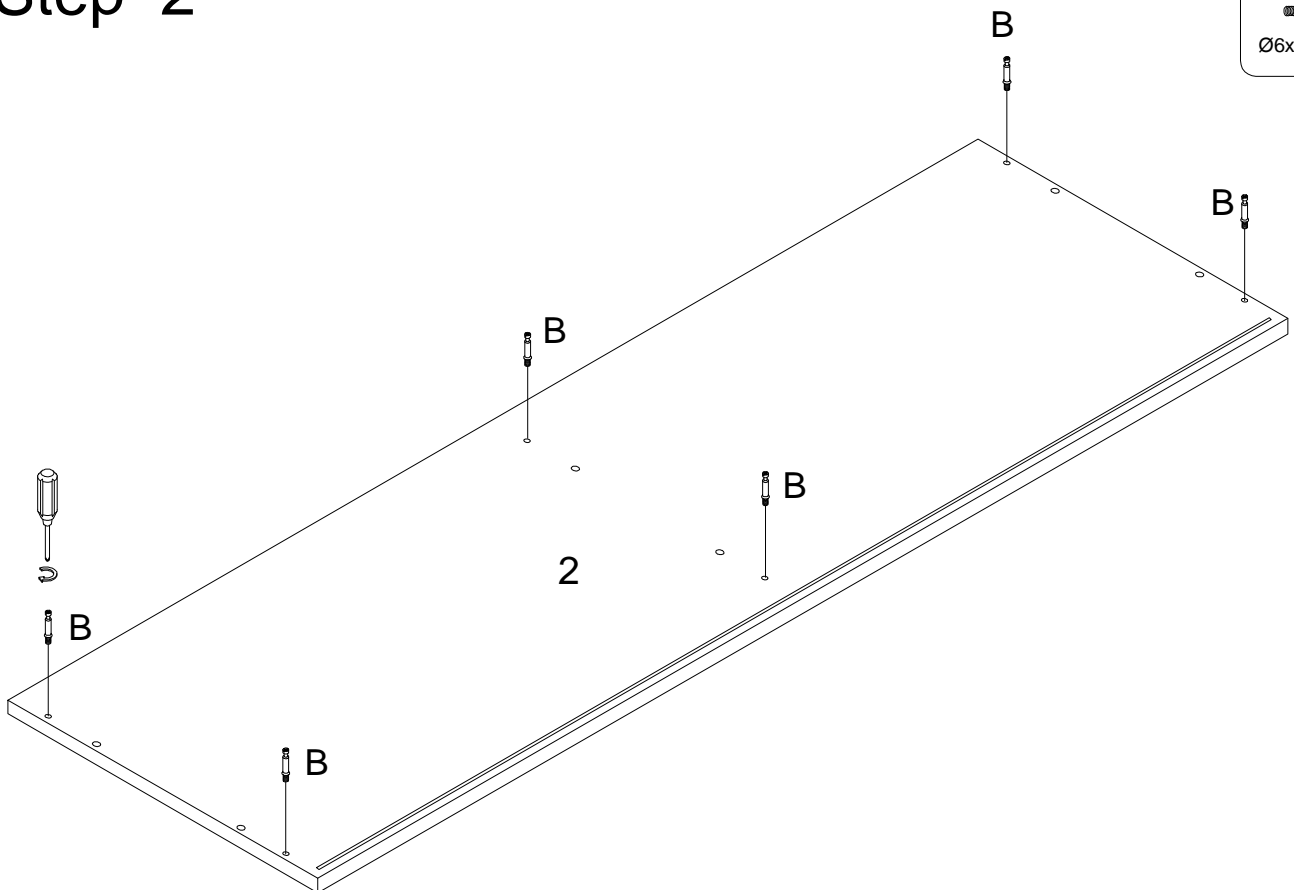
Ø6x35mm



Step 3

A x 12



Ø8x30mm

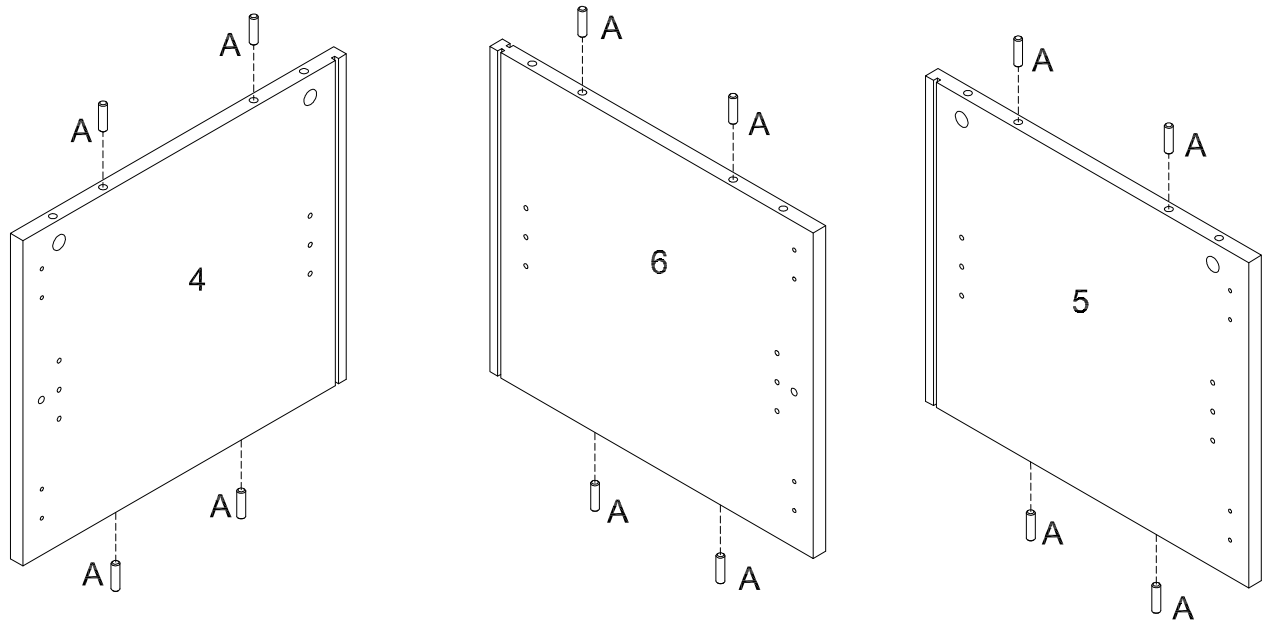

Step 4

E x 6



Ø6 x50mm

N x 1



4mm

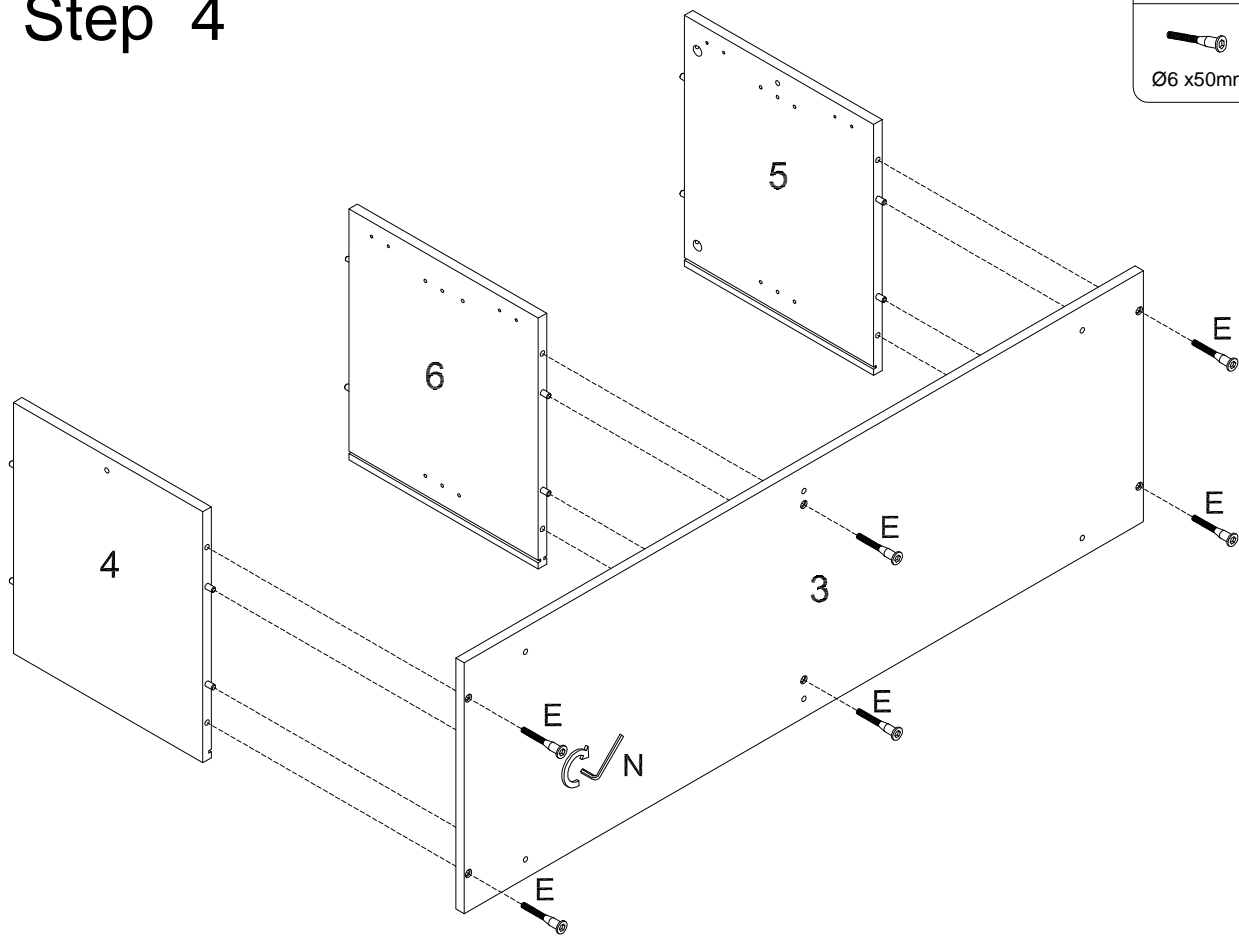

Step 5

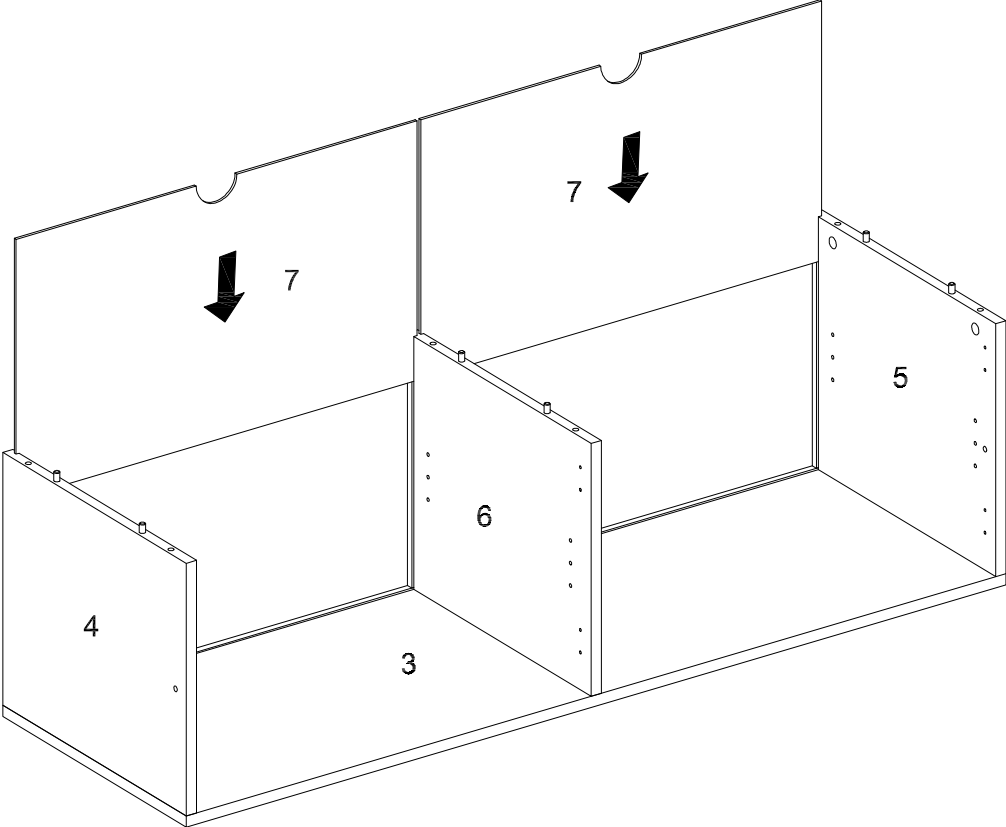

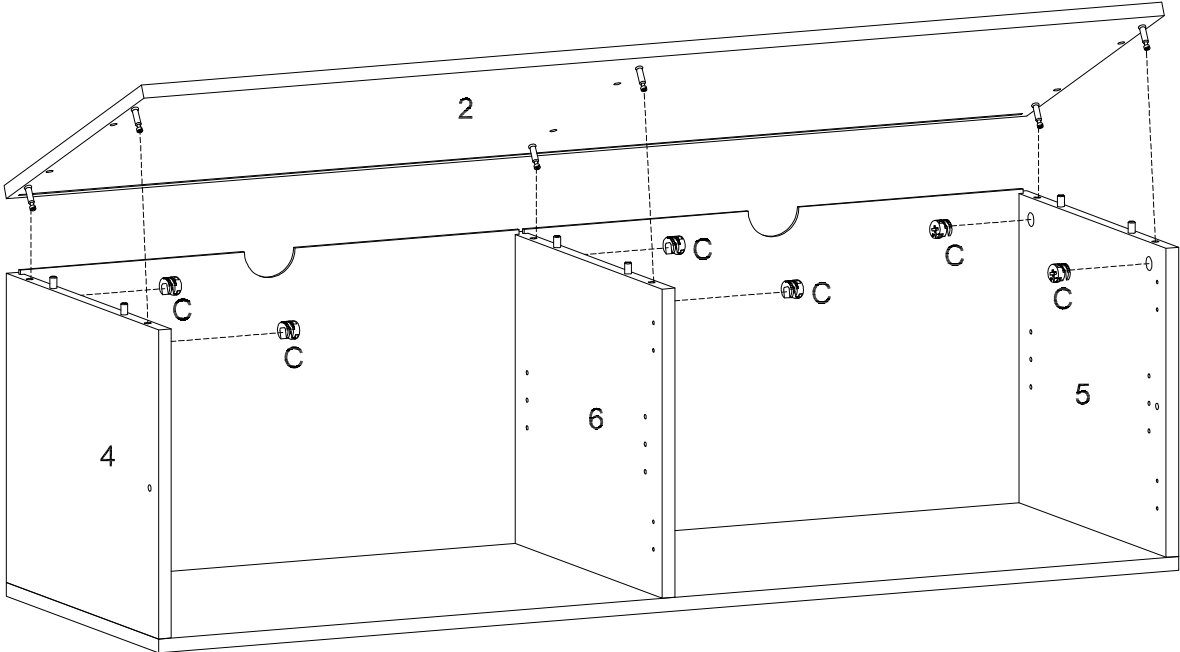

Step 6

C x 6

Ø15x11mm



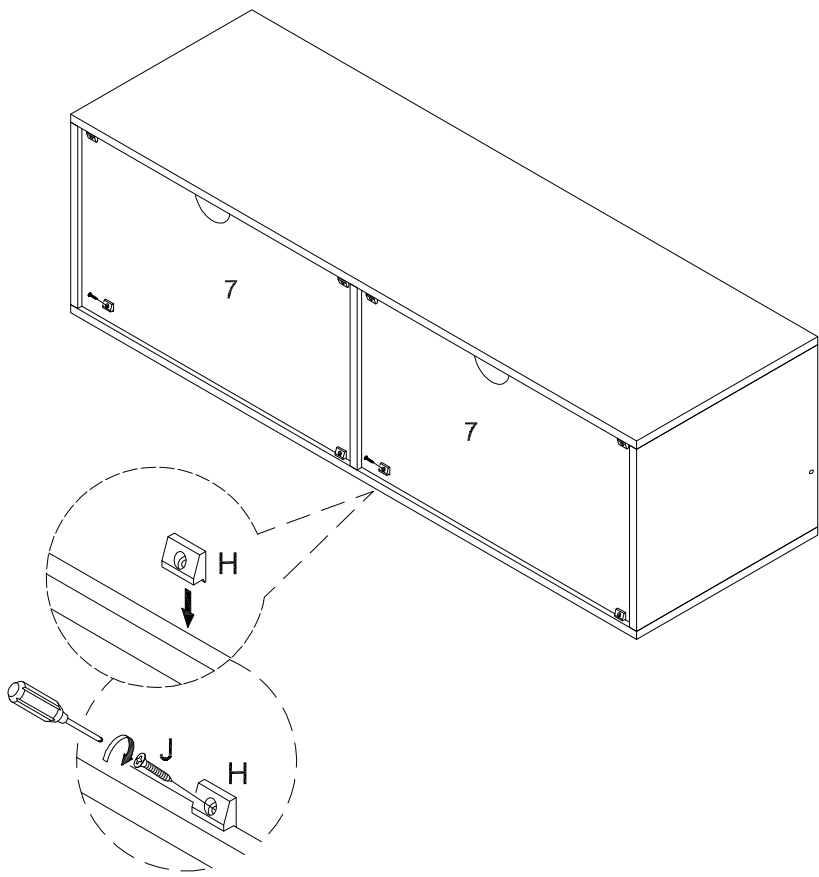

Step 7

H x 8	J x 8
	
	Ø3x17mm



Step 8

F x 3	G x 3	N x 1
		
Ø1/4"x12mm	Ø1/4"x25mm	4mm

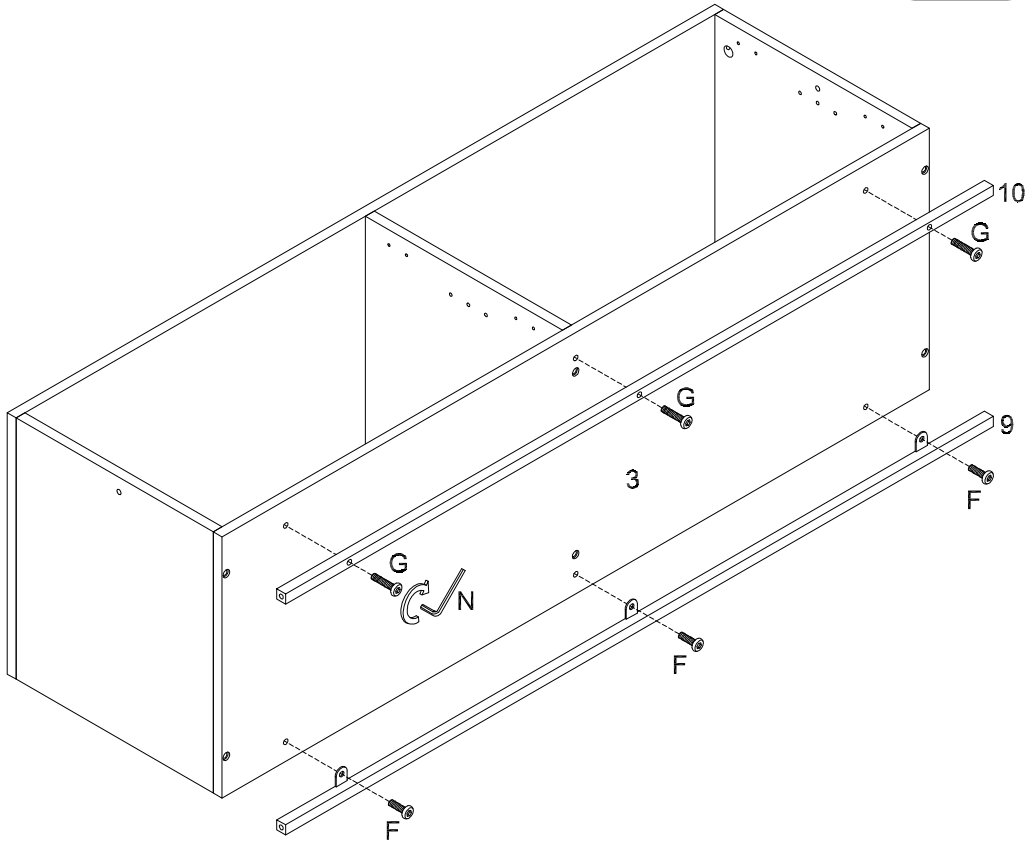

Step 9

F x 5
Ø1/4"x12mm

G x 3
Ø1/4"x25mm

R x 2

N x 1
4mm

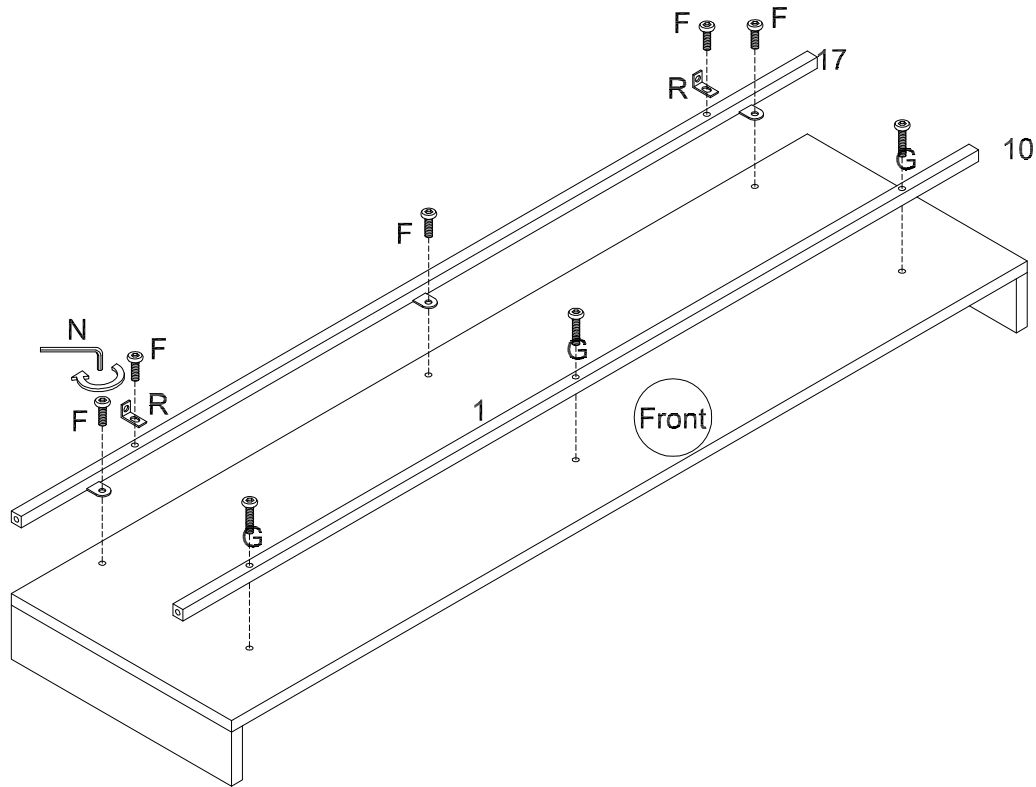



Step 10

G x 5
Ø1/4"x25mm

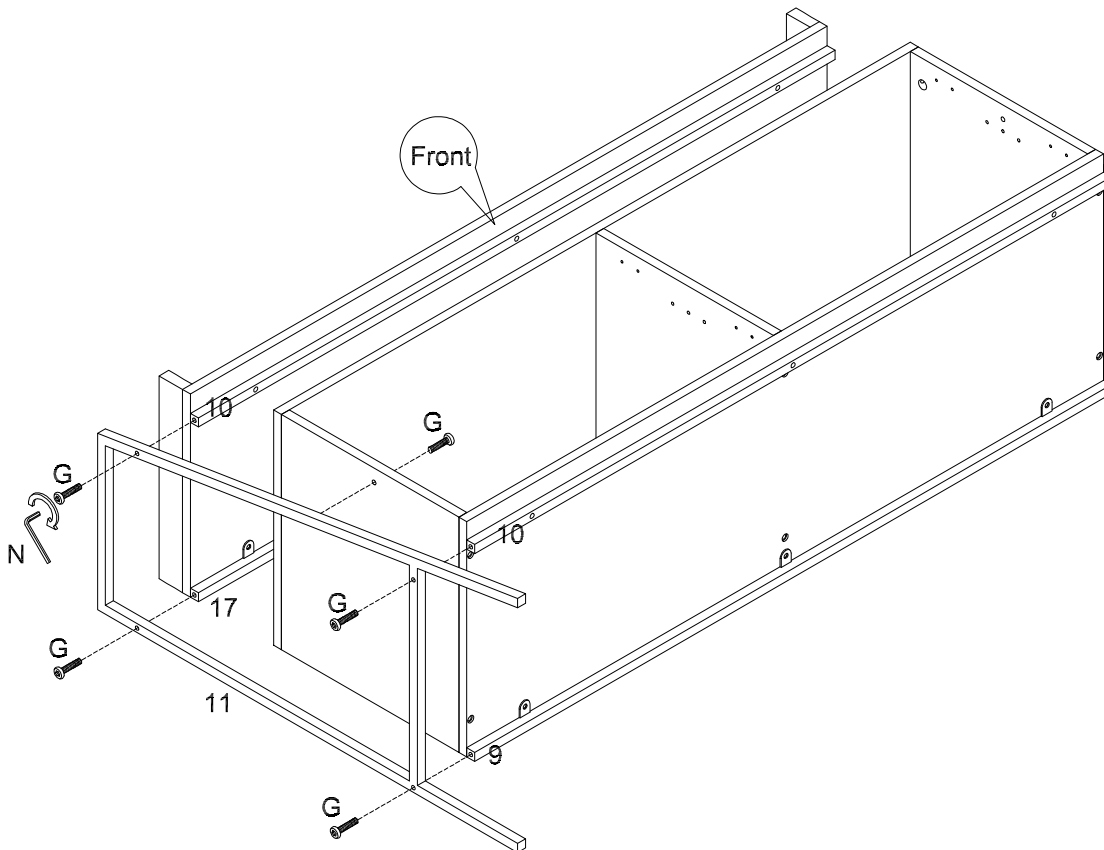
N x 1
4mm



Step 11

G x 5	N x 1
	
Ø1/4"x25mm	4mm

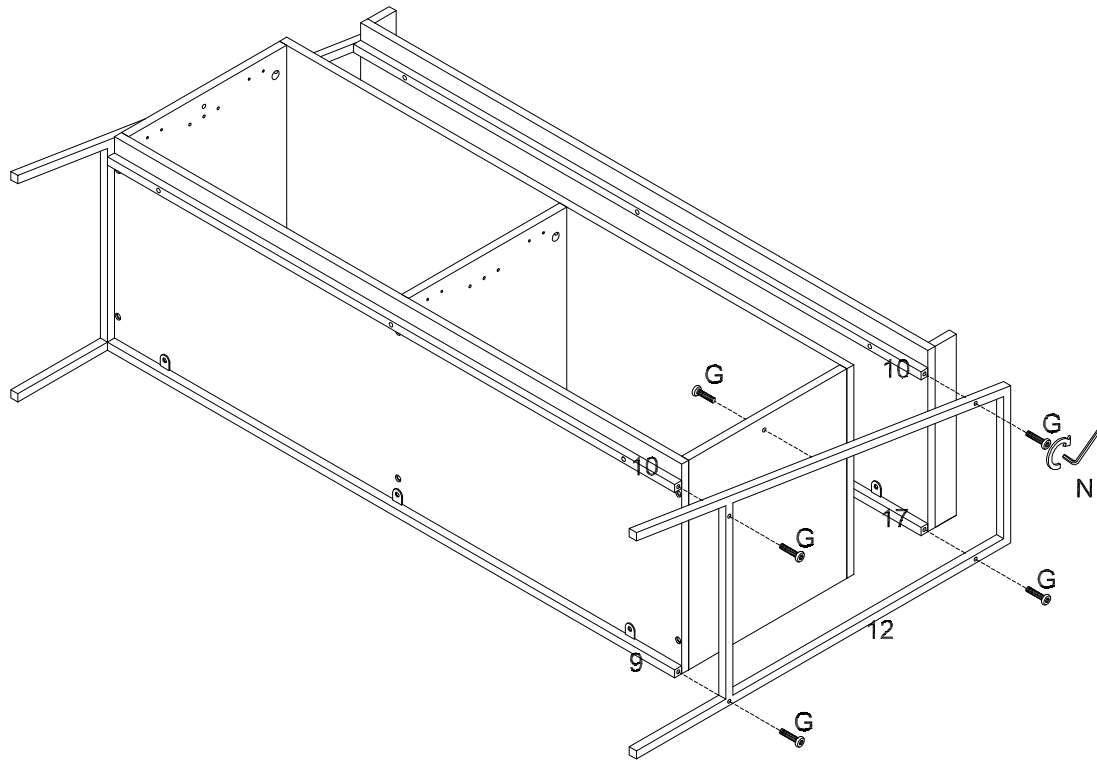

Step 12

D x 6

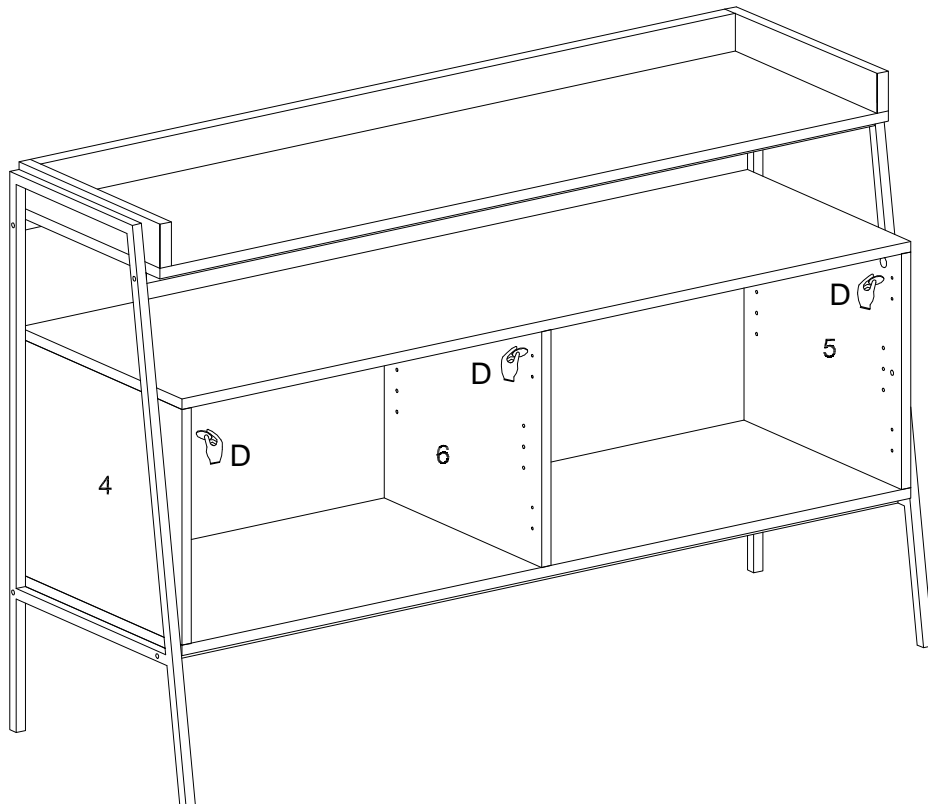

Step 13



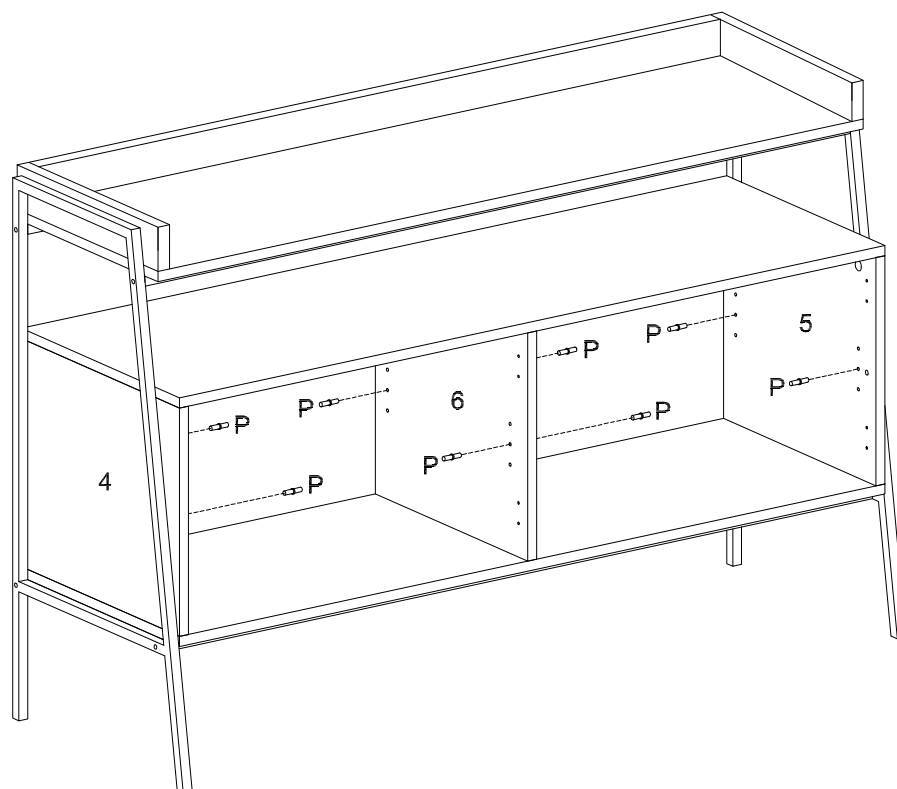

P x 8

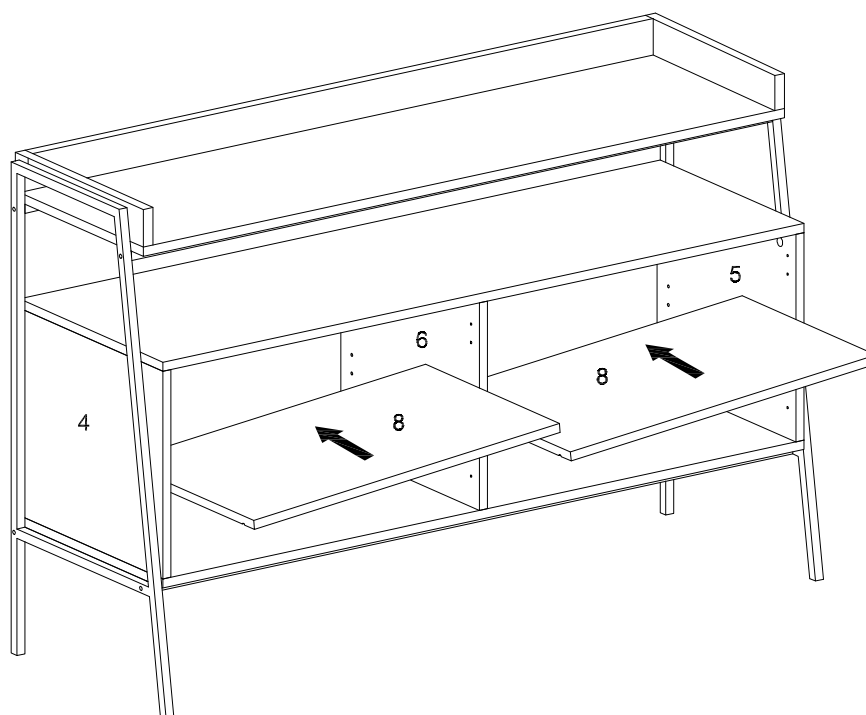

Step 14





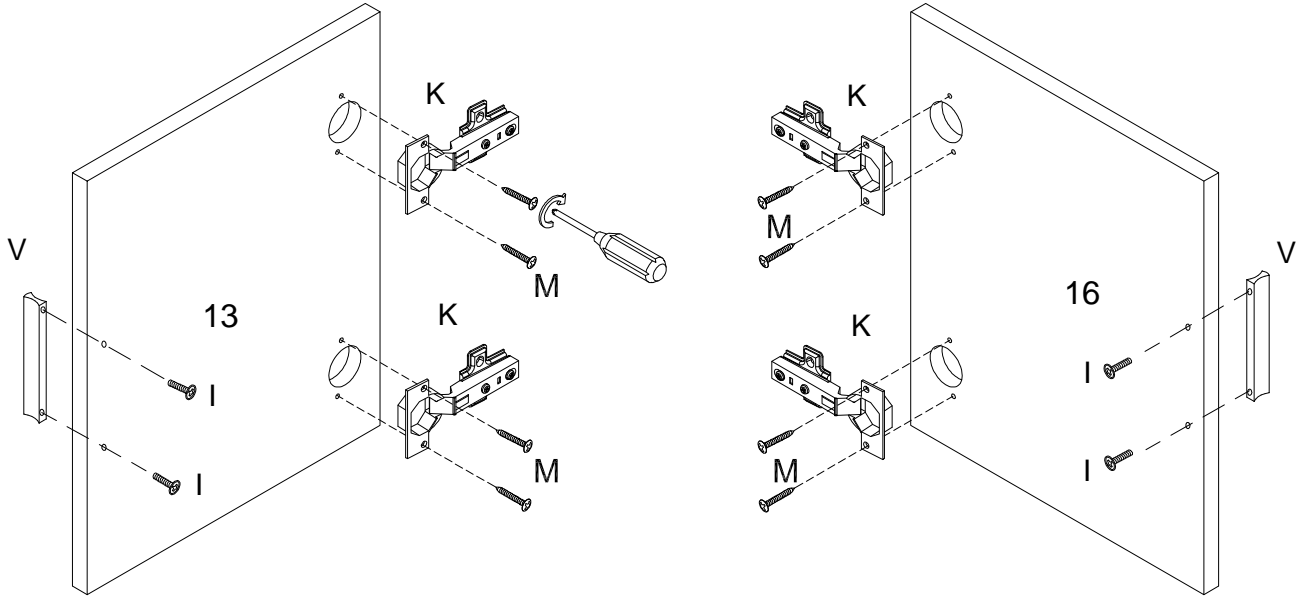

Step 15

I x 4  Ø4x16mm	M x 8  Ø3.5x14mm	K x 4 	V x 2 
--	---	--	--



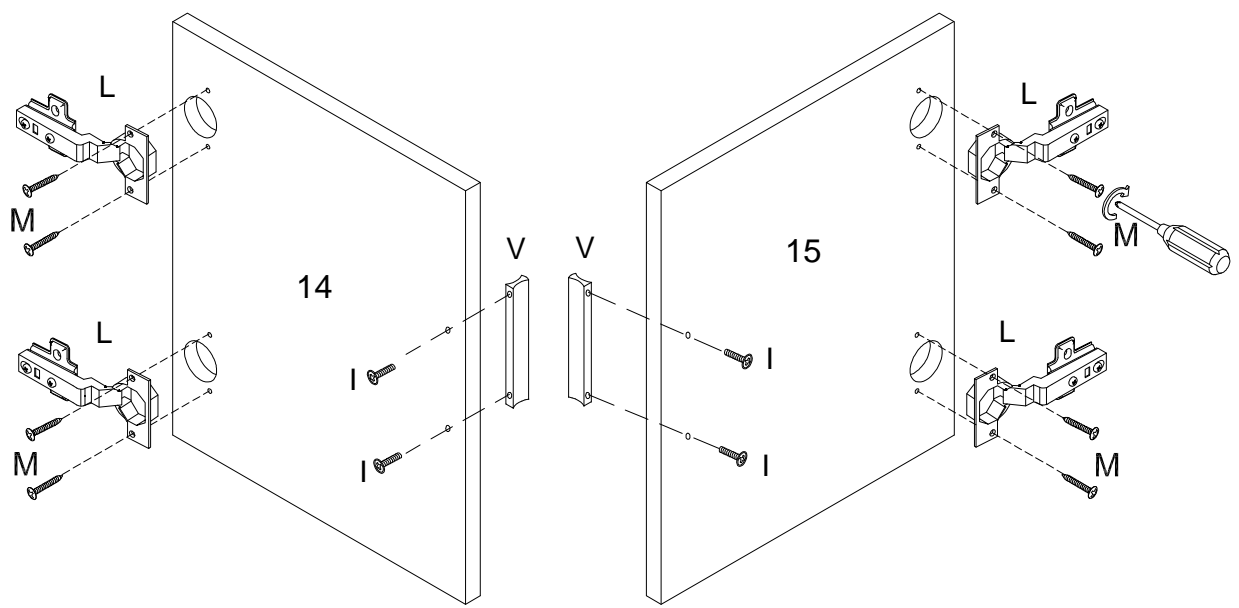

Step 16

I x 4  Ø4x16mm	M x 8  Ø3.5x14mm	L x 4 	V x 2 
--	---	--	--



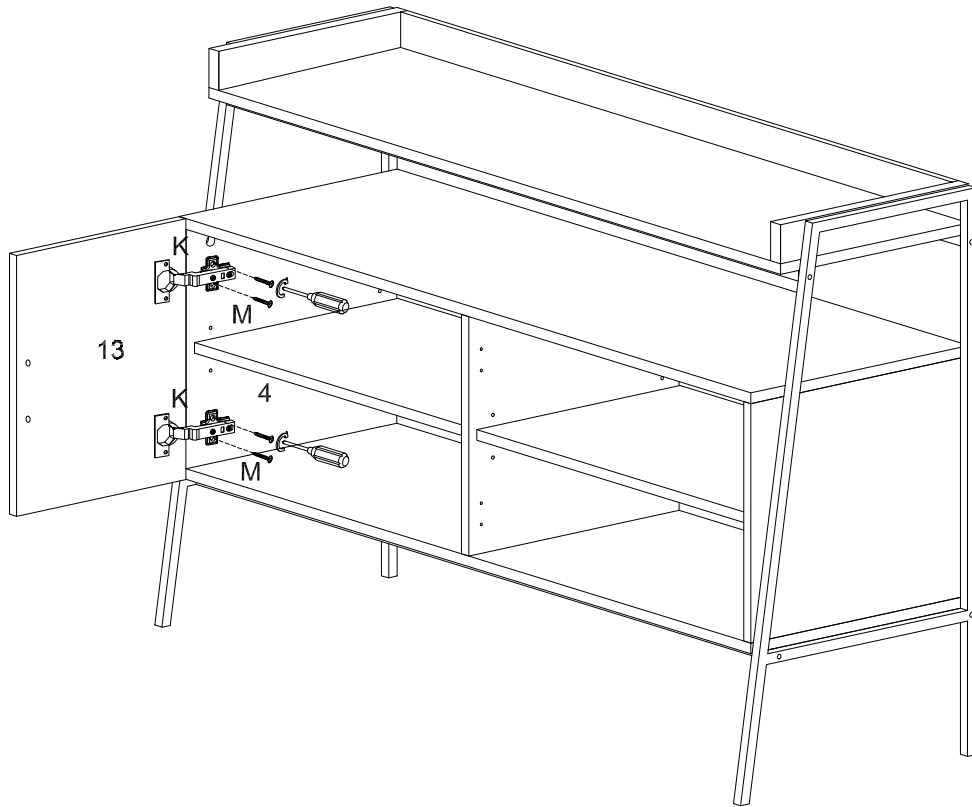

Step 17

M x 4	K x 2
 Ø3.5x14mm	



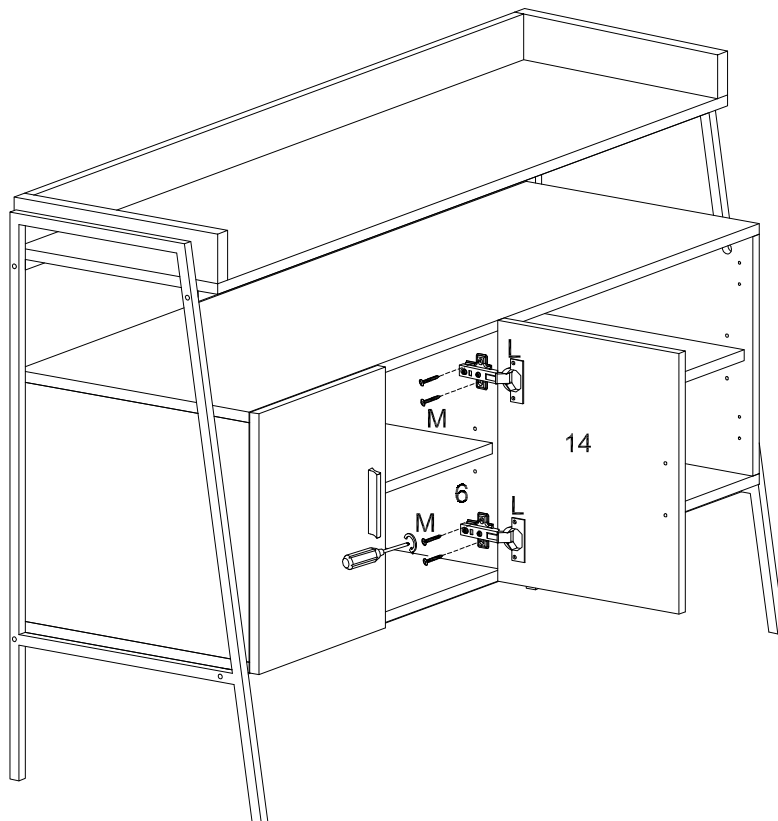

Step 18

M x 4	L x 2
 Ø3.5x14mm	



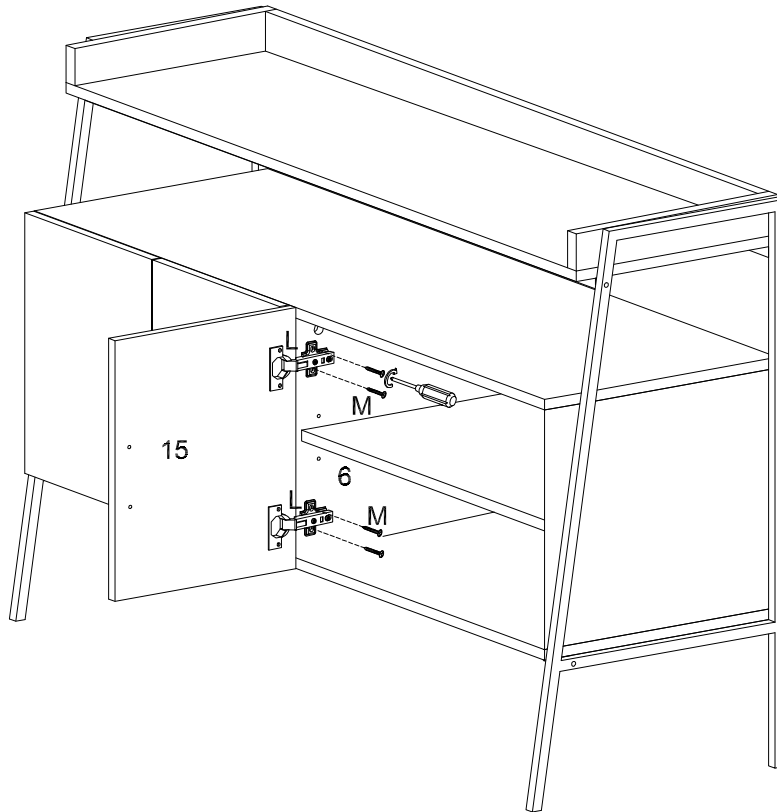

Step 19

M x 4	L x 2
	
Ø3.5x14mm	





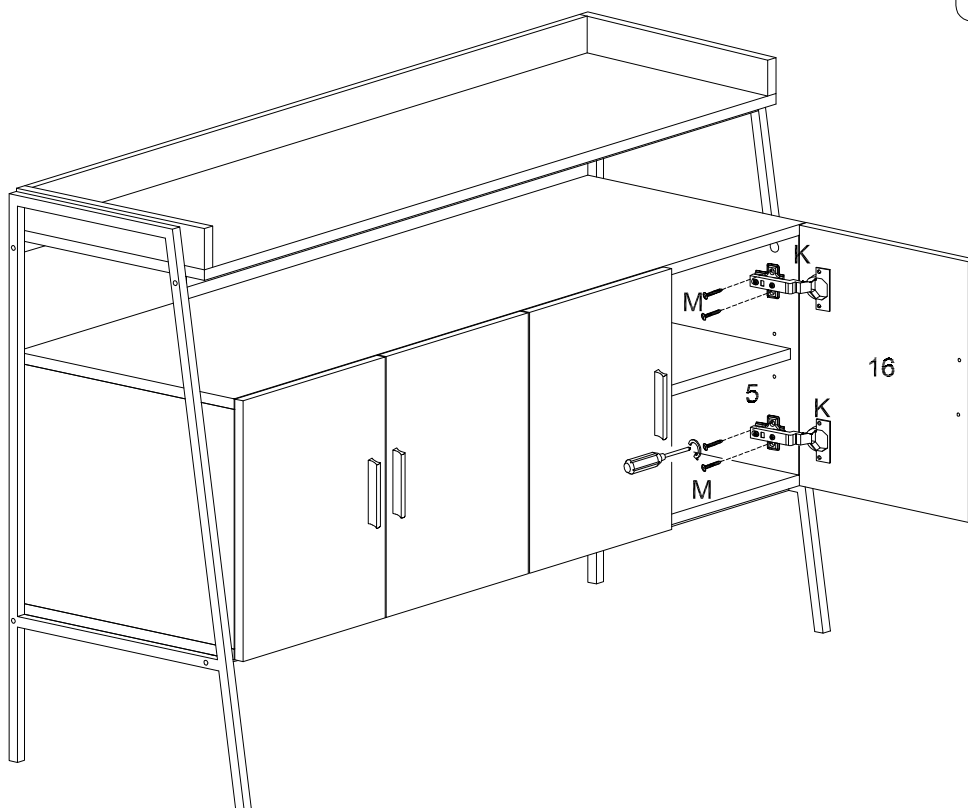

Step 20

M x 4	K x 2
	
Ø3.5x14mm	





Step 21

R x 2	S x 2	T x 2	U x 2
	 Ø4x30mm		

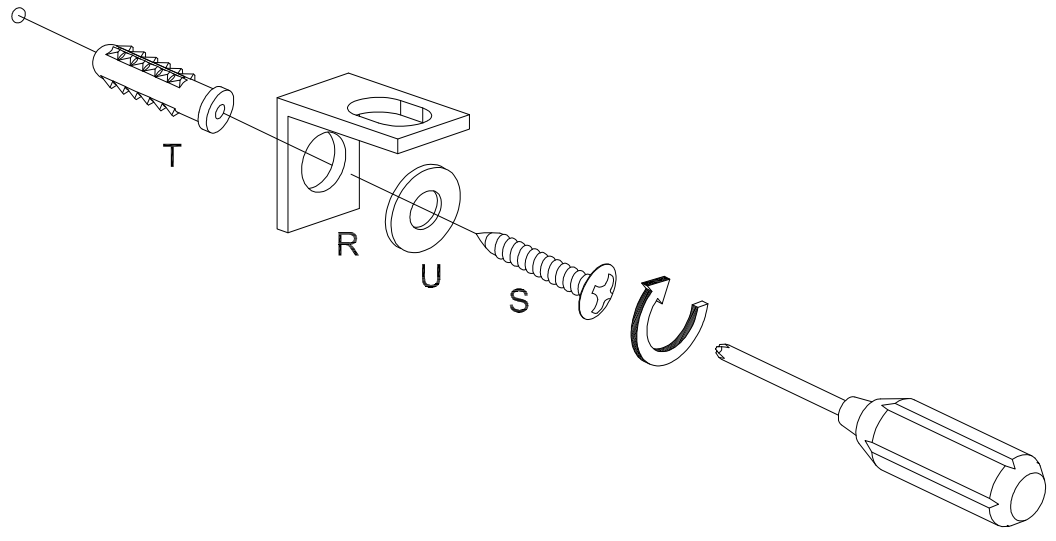
Wall

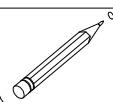

1	2
	

Step 22

