













# ASSEMBLY INSTRUCTION













Thank you for purchasing this quality product. Be sure to check all packing material carefully for small parts which may have come loose inside the carton during shipment. Separate, identify and count all parts and hardware. Compare with the parts list to be sure all parts are present.

**"DO NOT TIGHTEN SCREWS UNTIL COMPLETELY ASSEMBLED"**

## IMPORTANT:

PLEASE READ INSTRUCTION BEFORE STARTING THE ASSEMBLY

BOX 1 HARDWARES LIST				
ITEM	DESCRIPTION	DRAWING	SIZE	QTY
A	JCBB SCREW		M8 X 20MM	8PCS
B	JCBC SCREW		M6 X 15MM	6PCS
C	JCBC SCREW		M6 X 50MM	6PCS
D	SPRING WASHER		M6 X 12MM	6PCS
E	FLAT WASHER		M6 X 19MM	6PCS
F	SCREW		M4 X 32MM	8PCS
G	L - KEY		M5 X 65MM	1PC
H	L - KEY		M4 X 100MM	1PC
BOX 2 HARDWARES LIST				
I	JCBC SCREW		M8 X 35MM	20PCS
J	SPRING WASHER		M8 X 13MM	20PCS
K	FLAT WASHER		M8 X 22MM	20PCS
L	L - KEY		M5 X 65MM	1PC

BOX 1 PARTLIST			
ITEM	DESCRIPTION	DRAWING	QTY
1	HEADBOARD CUSHION		1PC
2	HEADBOARD LEG (R)		1PC
3	HEADBOARD LEG (L)		1PC
4	FOOTBOARD CUSHION		1PC
5	FOOTBOARD LEG		2PCS
7	SLAT		2PCS
8	CENTER SUPPORT		4PCS
9	SUPPORT LEGS WITH HANGERBOLT/LEVELER		8PCS
BOX 2 PARTLIST			
10	WALL PANEL (R)		1PC
11	WALL PANEL (L)		1PC
12	SUPPORT RAIL (LONG)		4PCS
13	SUPPORT RAIL (SHORT)		2PCS
BOX 3 PARTLIST			
6	SIDE RAIL (L/R)		2PCS

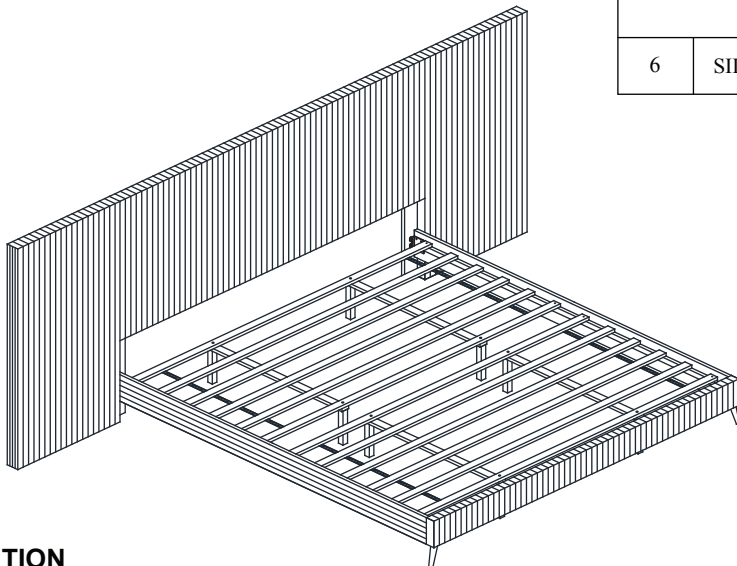

## ATTENTION

\*\*\* Some number parts listed on the instruction sheet may not be in parts bag as they may already be assembled. Carefully check parts and packing materials prior to ordering replacements.

# ASSEMBLY INSTRUCTION

STEP 1

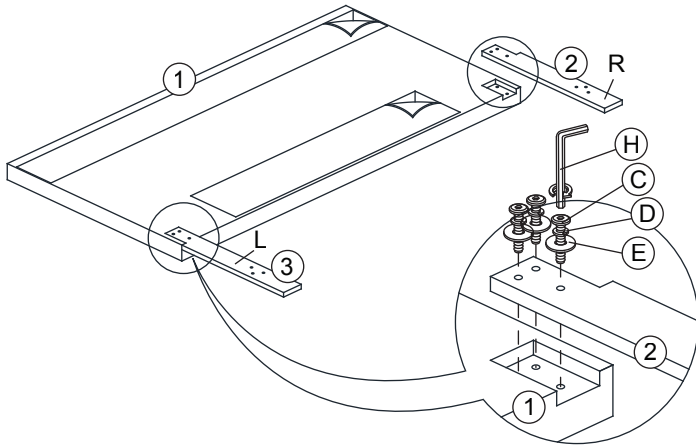

REMARK : Headboard leg with label facing backward.

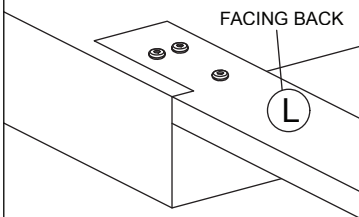

STEP 2

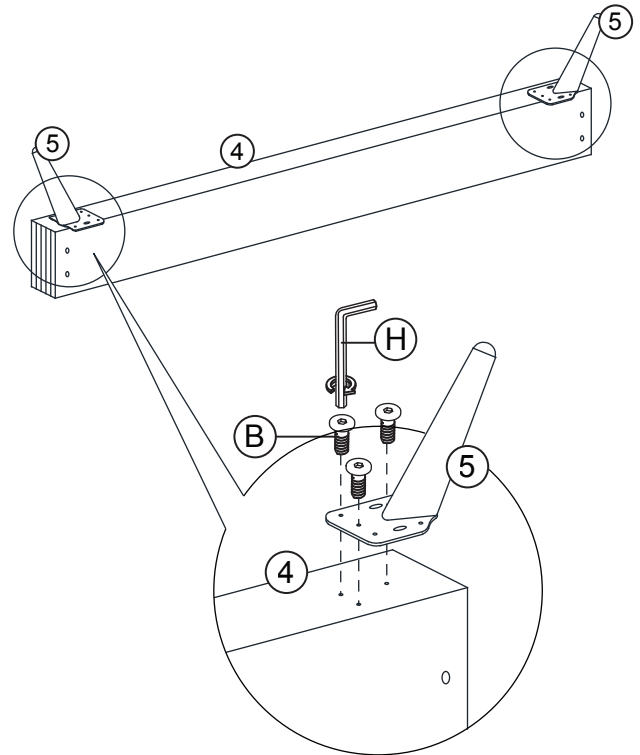

STEP 3

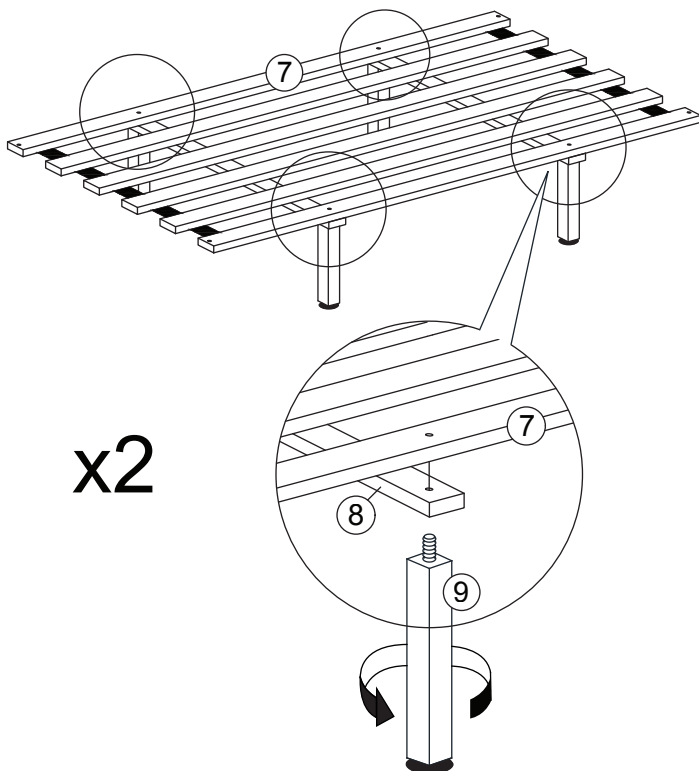

STEP 4

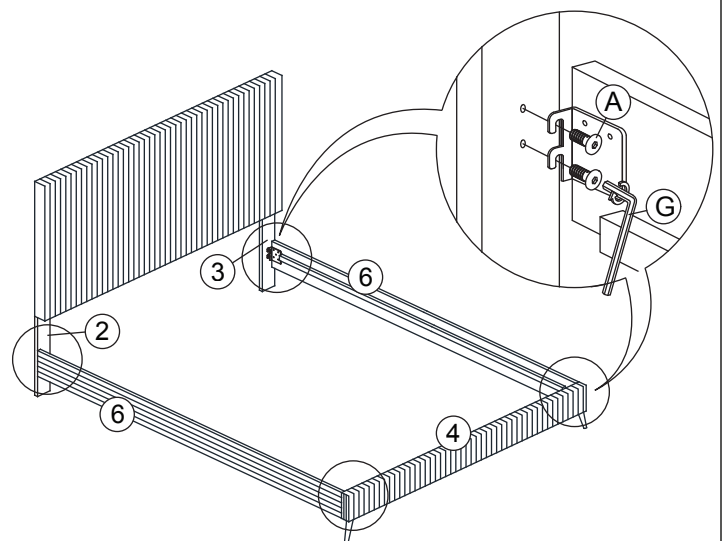

ASSEMBLY COMPLETED

# ASSEMBLY INSTRUCTION

STEP 5

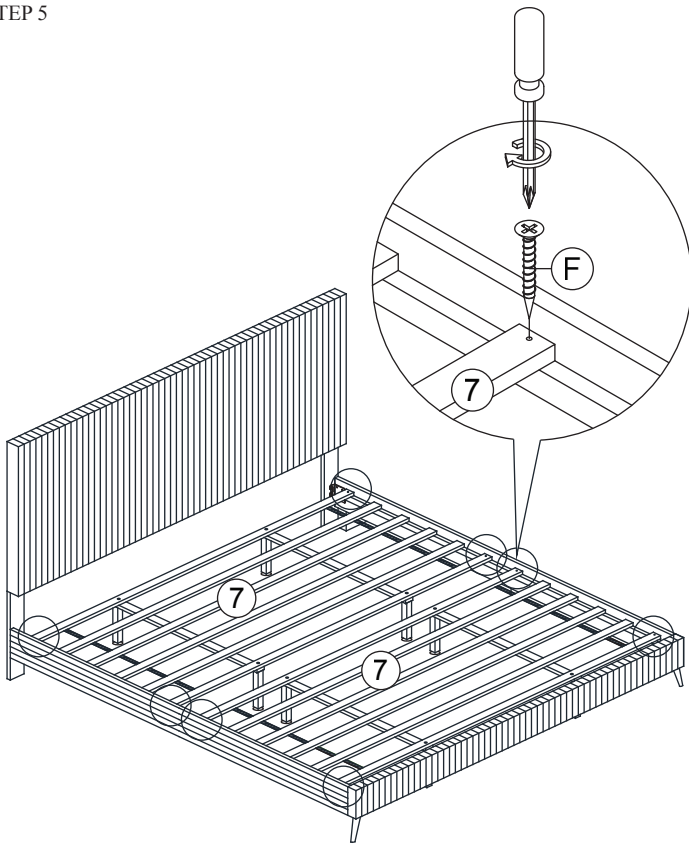

STEP 6

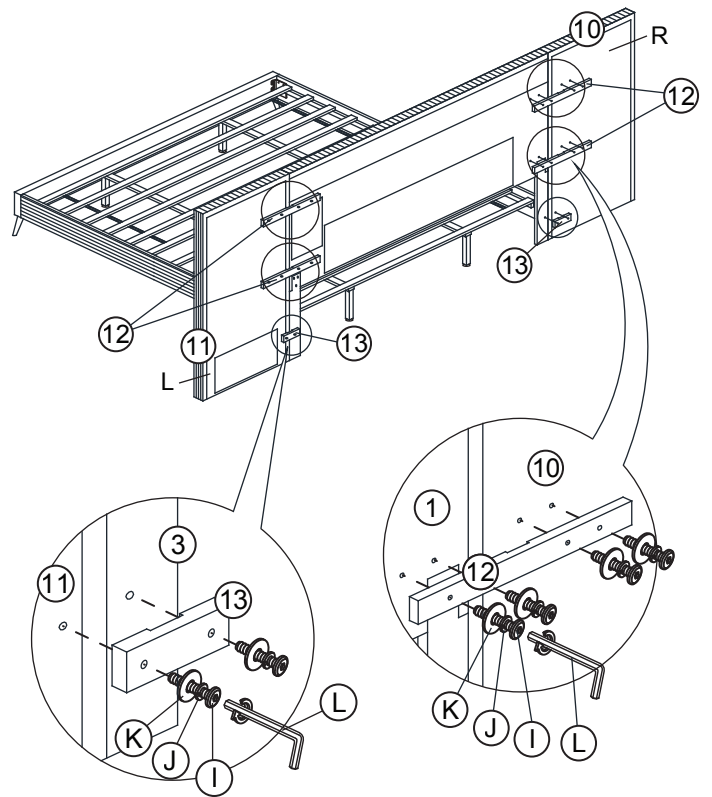

STEP 7

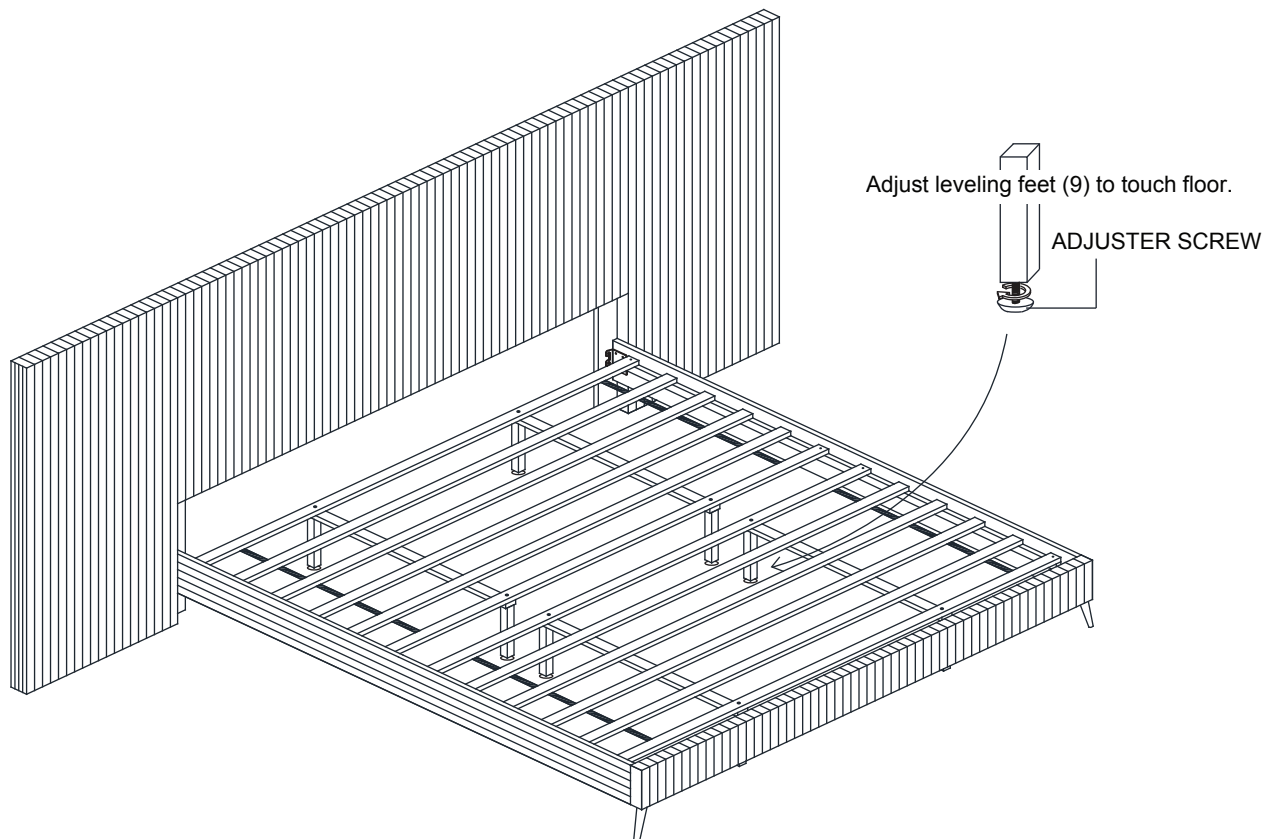

ASSEMBLY  
COMPLETED