

MR020 MANUAL

Manual Recliner Chair Swivel Glider
with Massage and Heat

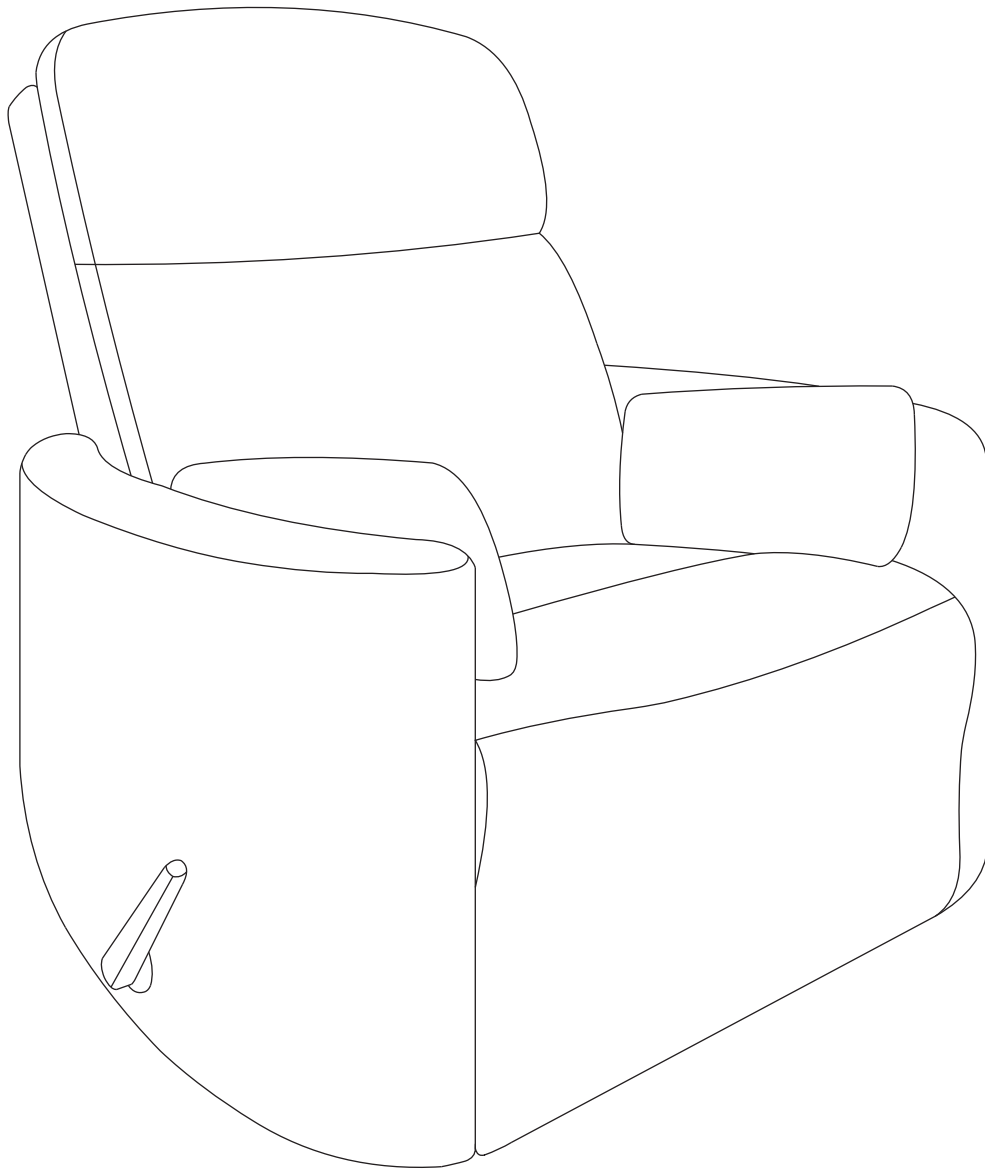

1. ASSEMBLE GUIDE

Thank you very much for choosing our product!



Please take time to read these instructions thoroughly and follow each step carefully for safe and easy operation. Keep this manual for future reference, especially for the safety information.

Also, it is better for you to assemble the chair in cooperation with 2-person, having a second person to help you makes it even easier.

Please read and understand this manual before any assembly. Before beginning assembly of product, make sure all parts are present. Compare parts with packaging contents list.

If any part is missing, damaged and any questions, please feel free to contact us.

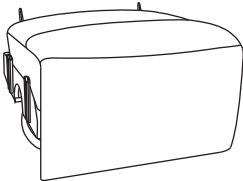
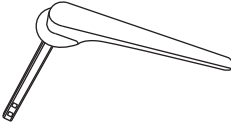
2. PARTS LIST

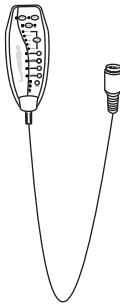
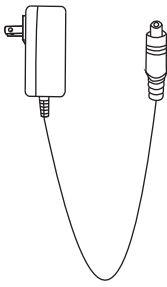
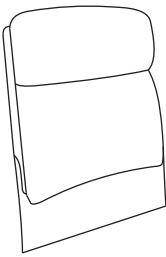
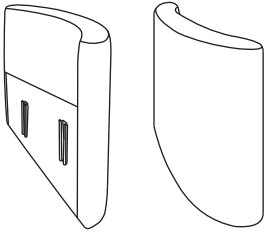
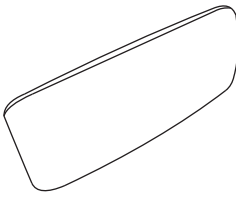
BOX 1			
Part	A	B	C
Description			
Qty	1PC	1PC	1PC
Part	D	E	
Description			
Qty	1PC	1PC	
BOX 2			
Part	Description		Qty
F			1PC
BOX 3			
Part	G	H	
Description			
Qty	2PCS	2PCS	

3. ASSEMBLY STEPS

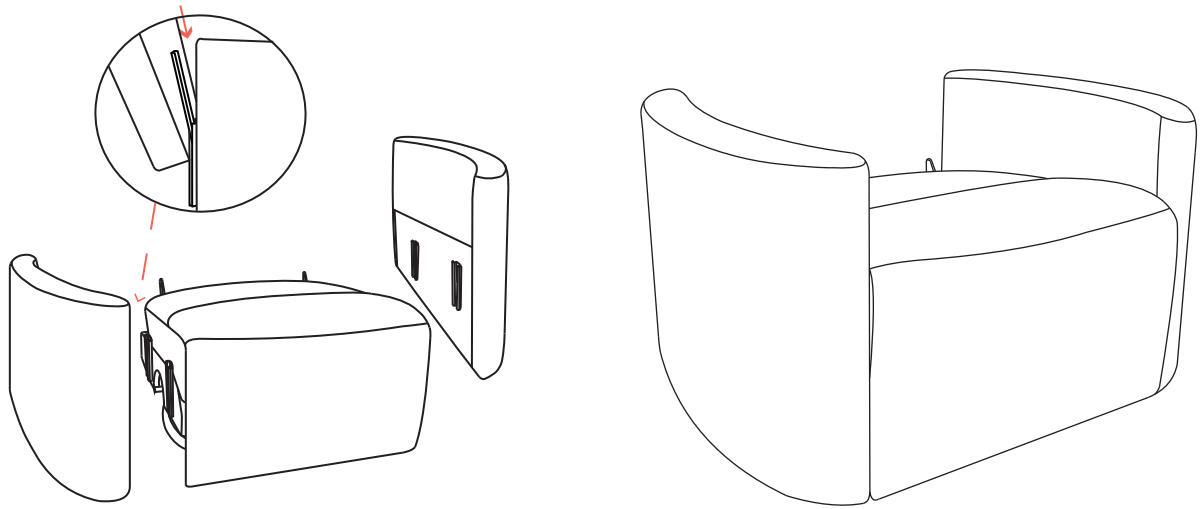

Step1: Insert the pins to secure the left and right armrests to the seat.

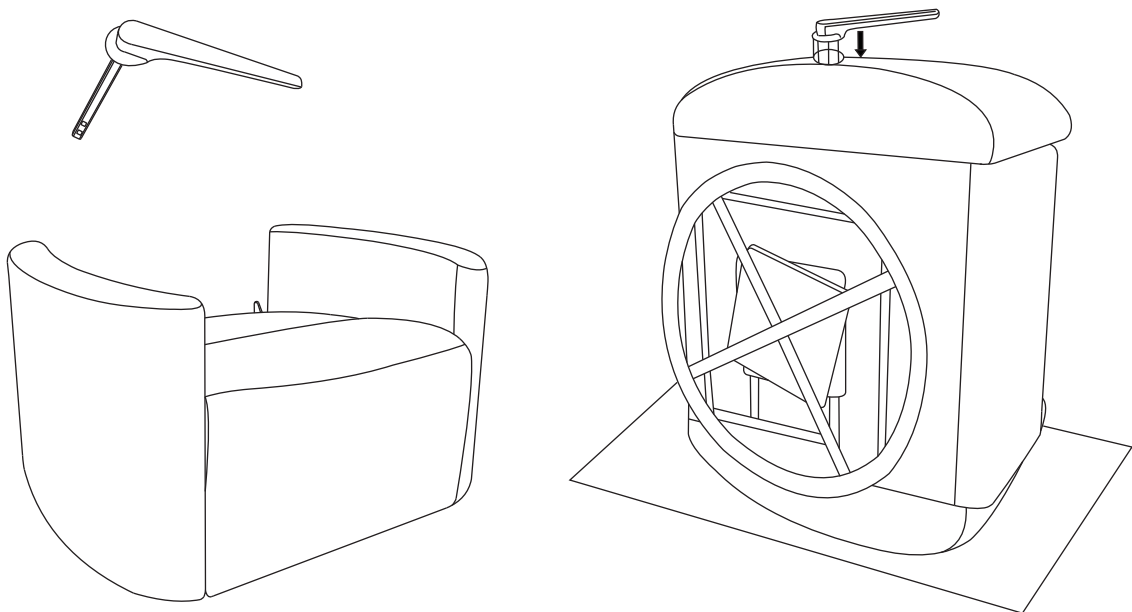

Step2: Place the seat on its side and insert the hand crank into the base.

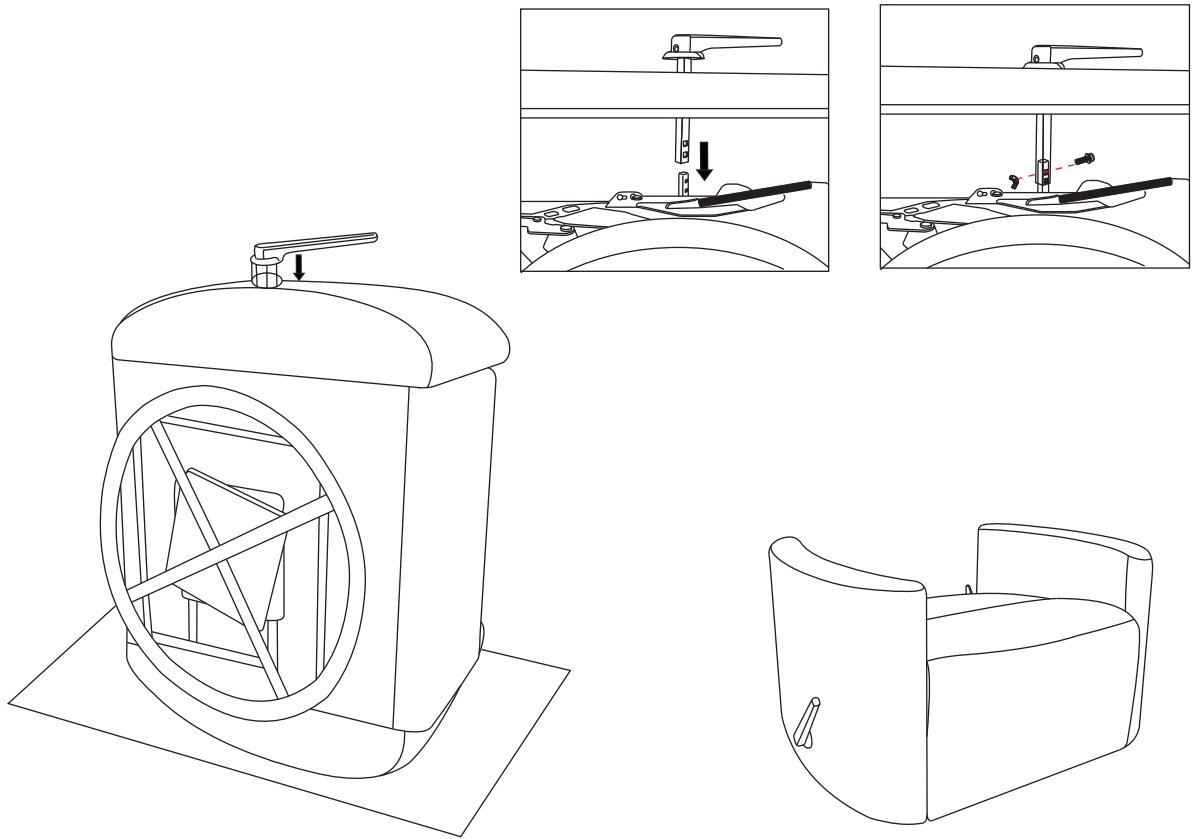

Step3: Secure the hand crank to the seat with the screw and tighten the nut. **Note:** There are two screws inside the accessory box, you only need to install one for normal use, the other is free and can be used as a spare.

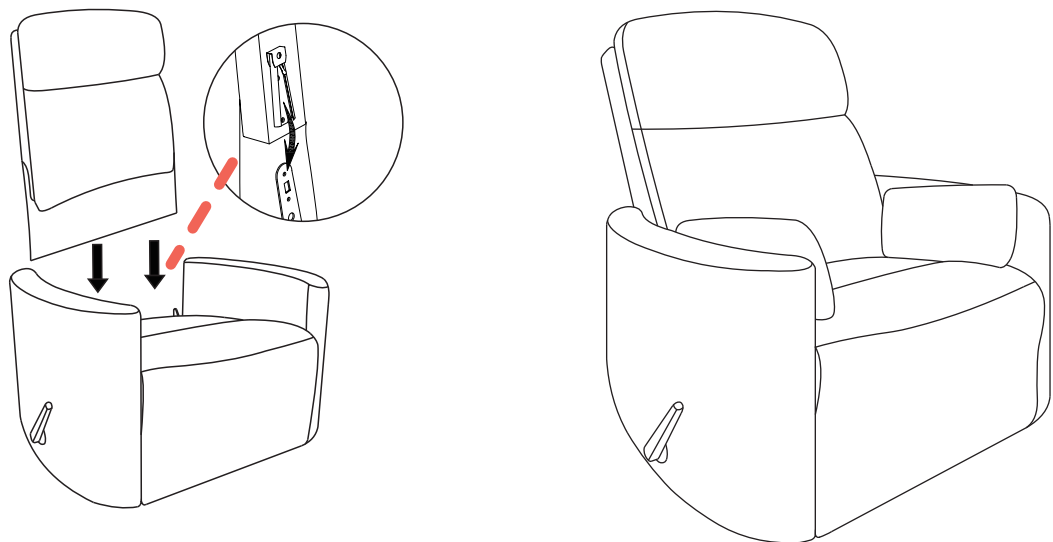

Step4: Insert the backrest into the seat, assembly is complete.

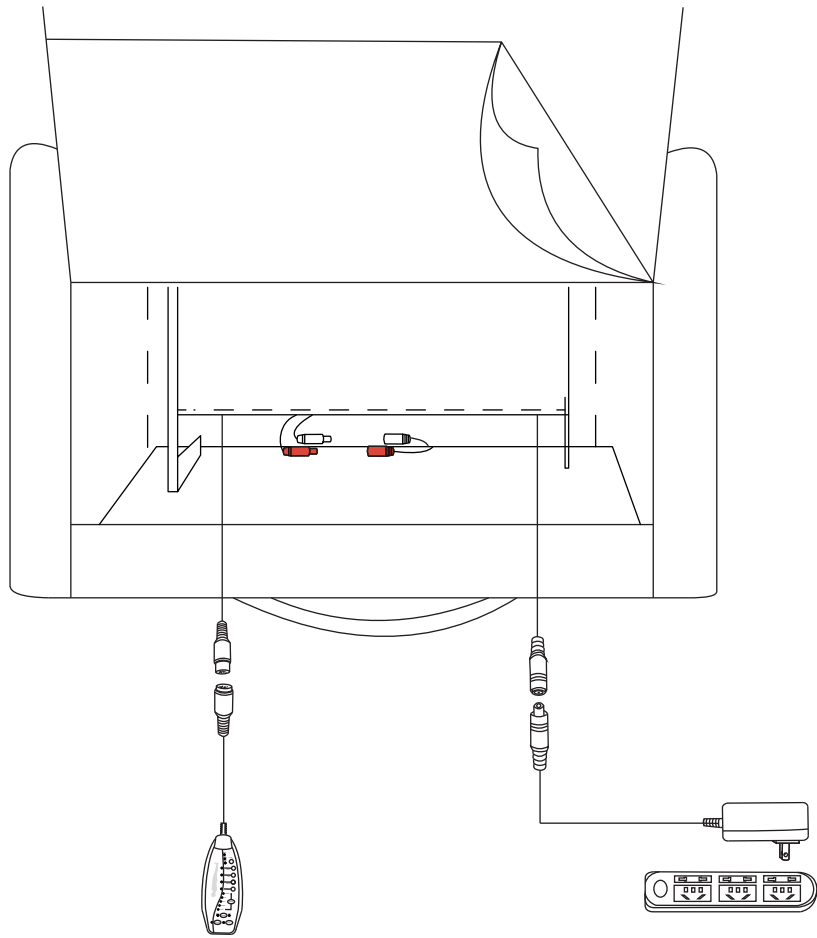

Step5: connect the remaining power cables one by one as shown in the diagram. Please note: The USB socket in the bottom of the recliner armrest.

4. OPERATING INSTRUCTIONS

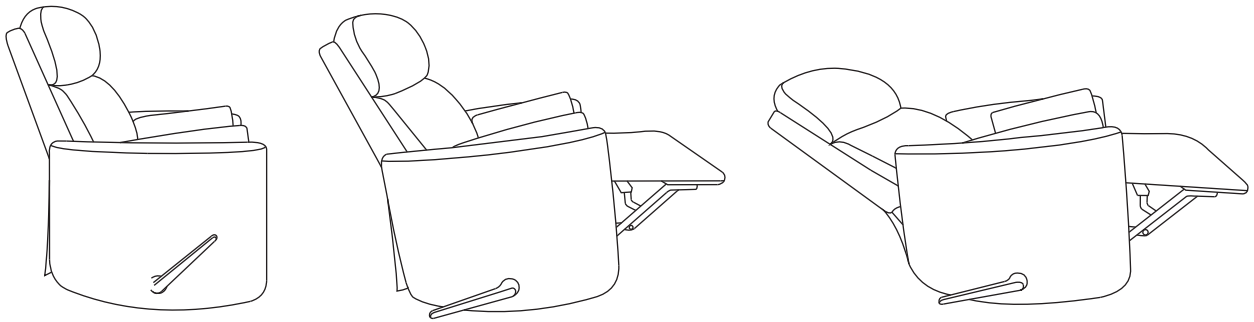

Push the hand crank backwards to open the footrest and forwards to close it.

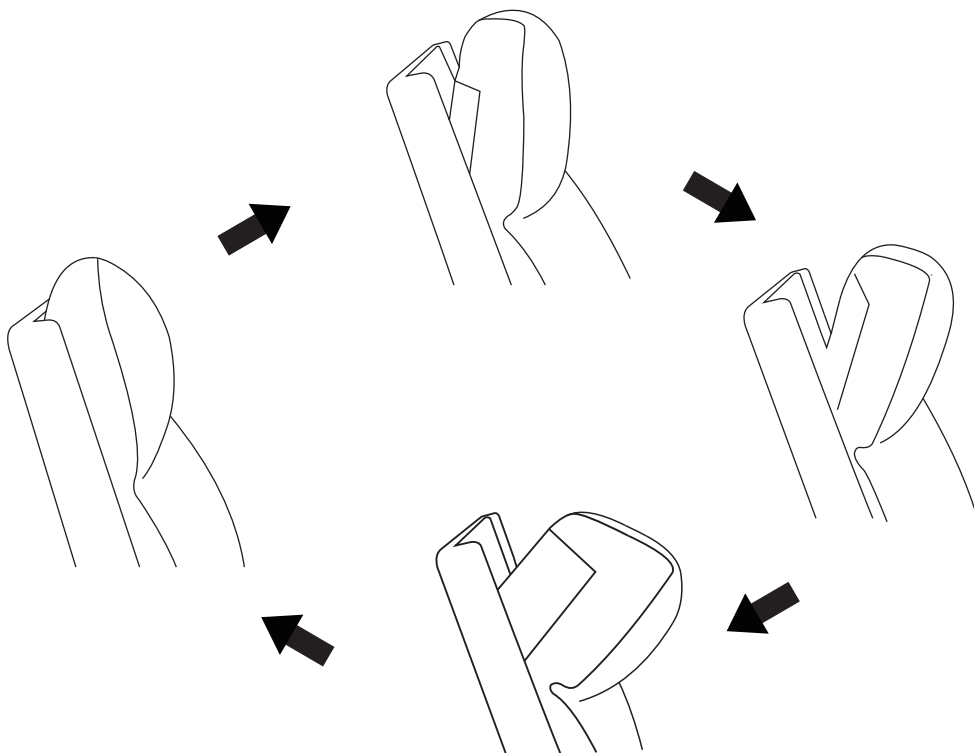

Push the hand crank backwards to open the footrest and forwards to close it.

5. TROUBLESHOOTING

1. What should I do if my shipment is damaged or products received are defective?

We're sorry to hear that! Please contact us on the Amazon platform and provide a detailed description of the damage, as well as photos (or videos, where appropriate) showing the damage. We will do our best to resolve the issue as soon as possible.

2. Can replacement parts be ordered?

Just write to our customer service team on Amazon and let us know your order ID. and we will be happy to provide further assistance.

3. Who do I contact for repair queries?

Easy! Just email us at Amazon and provide a detailed description of the fault as well as photos.

4. How do I claim my warranty?

You can write to us to specify your inquiry, and we will be able to assist you further.

6. What should I do if I want to return the product?

We offer 30-day return policy upon product received. To initiate a return request, please message us through Amazon and with your reason of returning so we can facilitate the request and assist you further. For more details on the return policy, please refer to Return section.

6. PRODUCT CARE

- Dust regularly with a soft, dry cloth to prevent soil build-up. Keep away from heat to avoid glazing, melting or scorching. Use a professional cleaning service to clean the fabric.

7. WARNING

- This product is not intended for institutional or commercial use.
- FALL HAZARD - To prevent death or serious injury, always keep child within arm's reach.
- Avoid placing this item in direct sunlight to prevent fading.
- Check this product for damaged hardware, loose joints, missing parts or sharp edges before and after assembly and frequently during use.

customer service

Any Problem Please Contact Us

- If you have any questions, please provide the order number and related pictures to show the problem through Amazon email. We will reply to you within 24 hours, and solve the problem as soon as possible.



Amazon Message