



NOTE:

This brochure contains IMPORTANT safety info. Please read and keep for future reference.

MAINTAINANCE AND WARNING

- 1.Keep furniture away from heat sources.
- 2.Do not clean furniture with harsh cleaner or polishes.Do not use detergents,solvents,abrasives,spray packs or leather cleaner. Use non-color mild soa with warm water to clean spills(Mix 1:10 soap to water).
- 3.Do not place furniture under direct sunlight,material will possibly fade over time.
- 4.Do not use on site dry cleaning machine.Children should not climb or jump on the furniture.
- 5.Do not write on furniture that is not protectedby a padded barrier.
- 6.Not for commercial use,only for residential use.

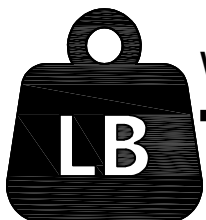

Weight Limitation

LB 70 LBS

EXPLOSIVE VIEW

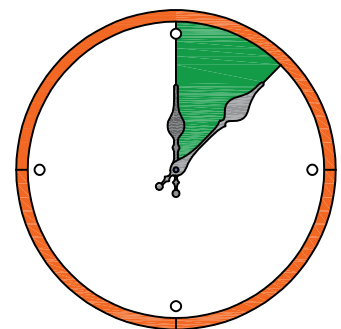
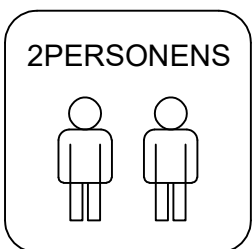
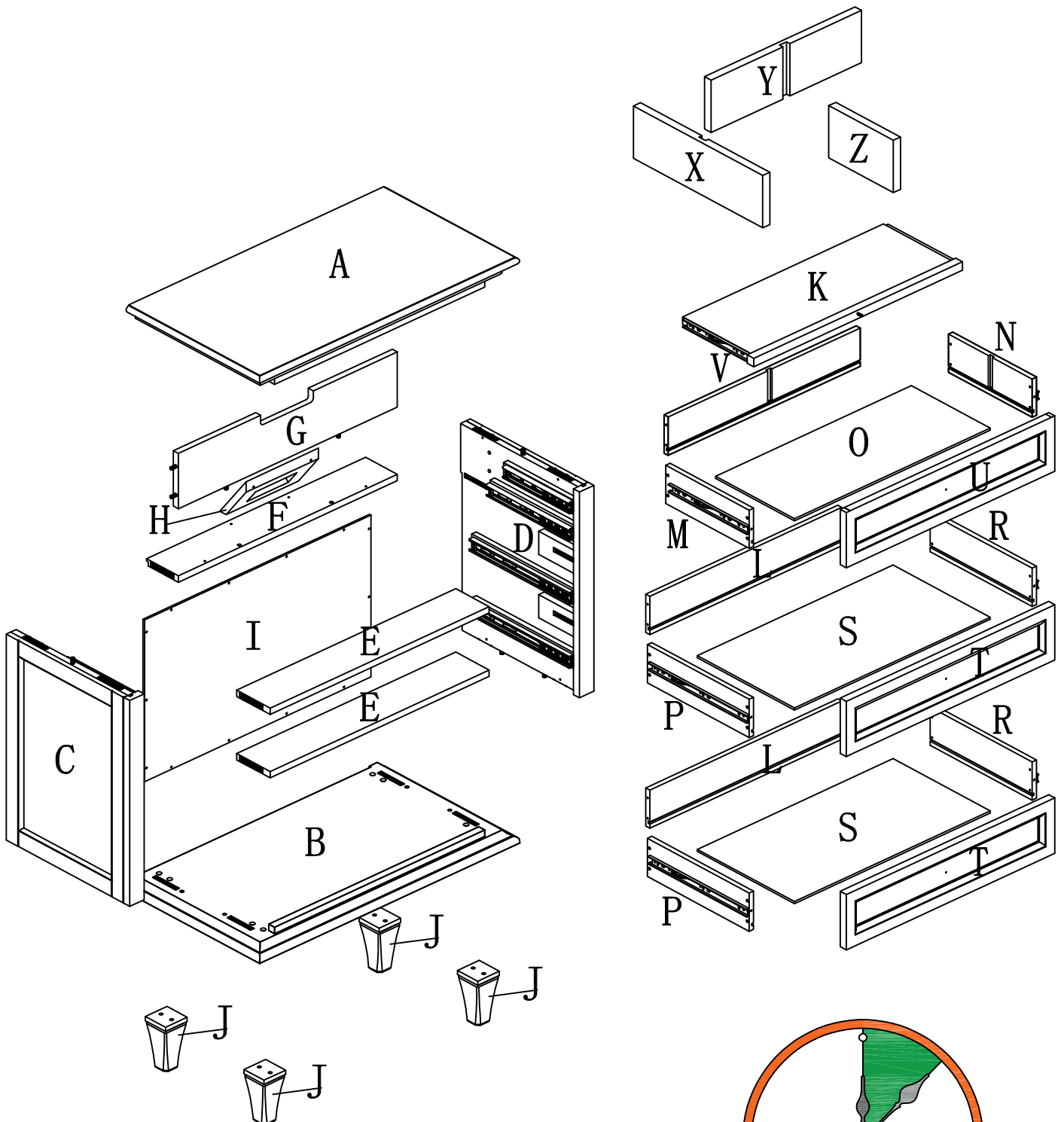

Around 80 min



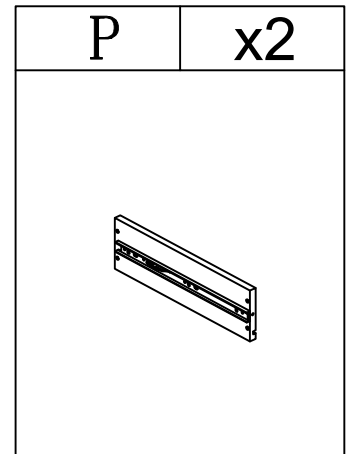
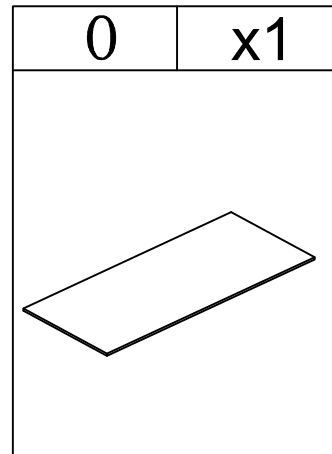
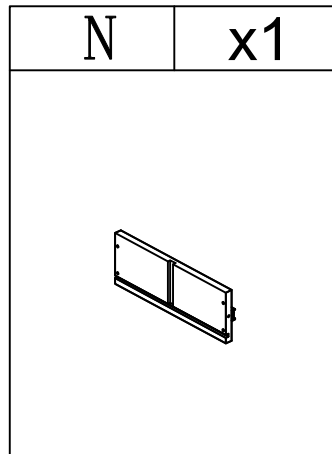
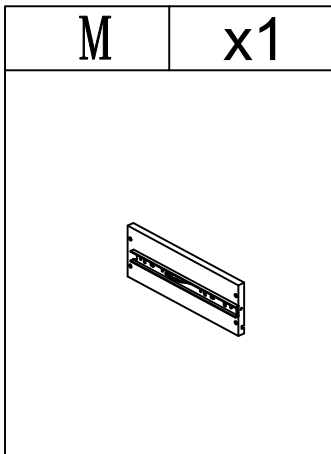
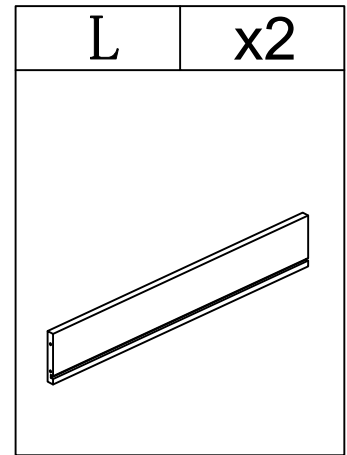
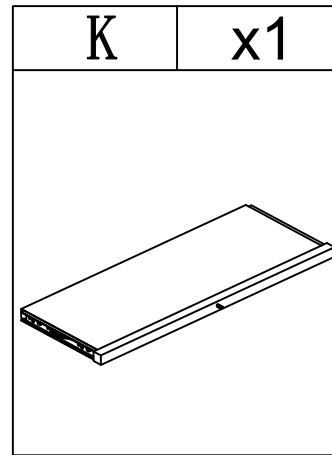
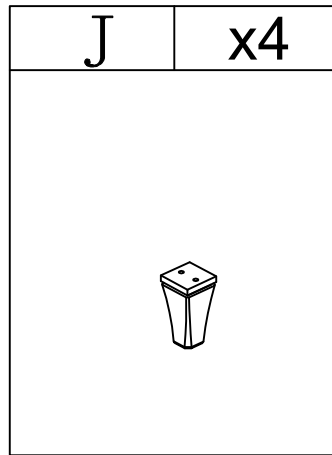
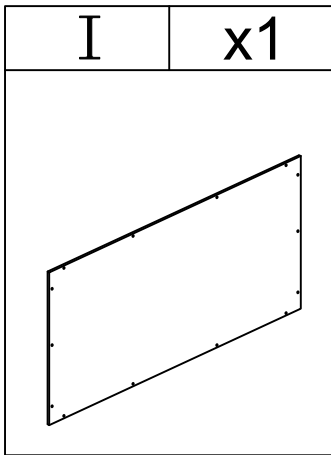
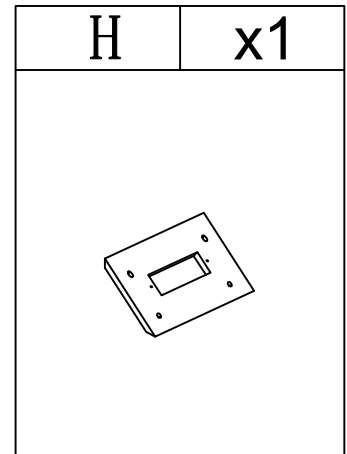
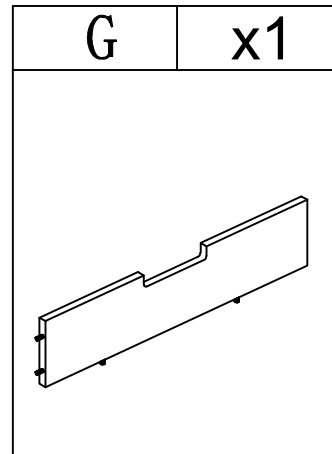
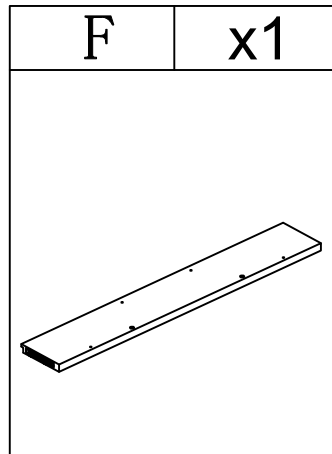
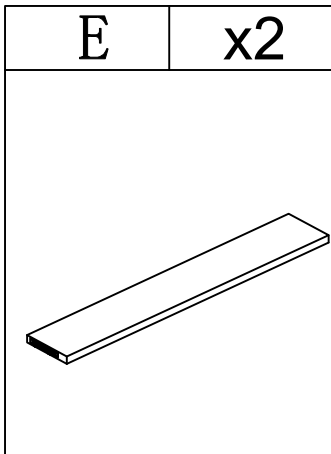
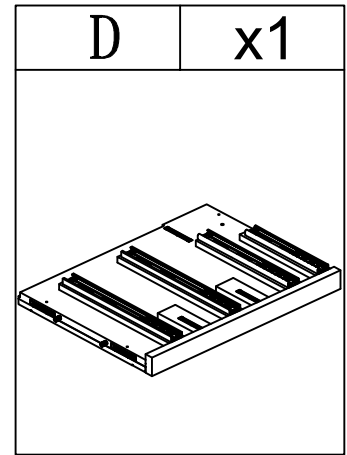
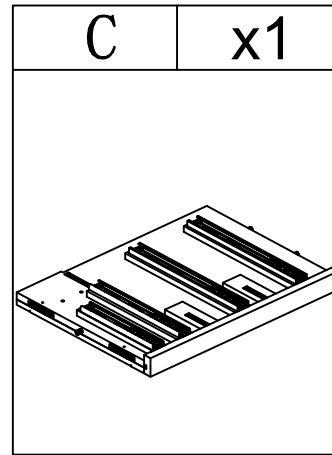
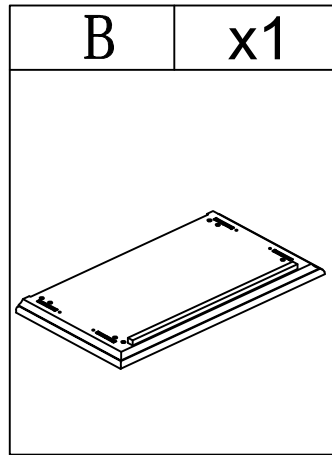
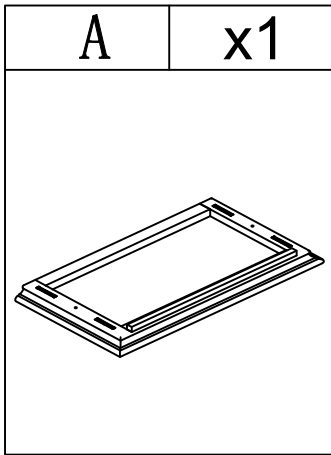



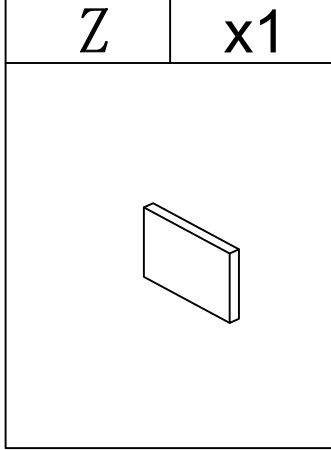
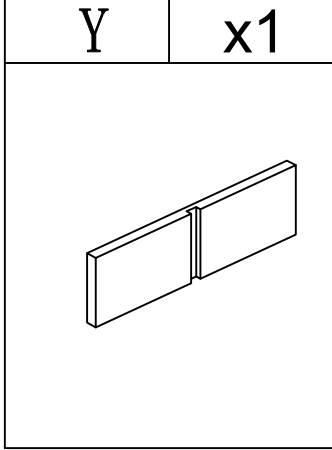
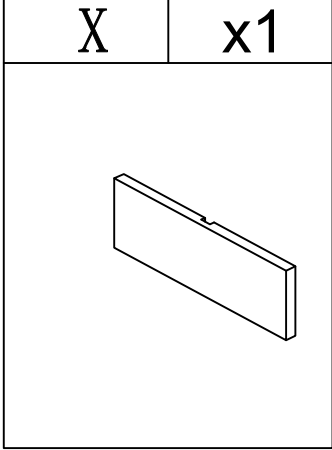
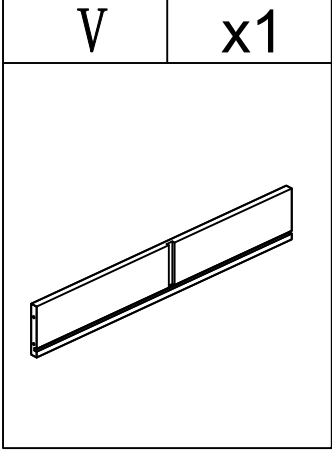
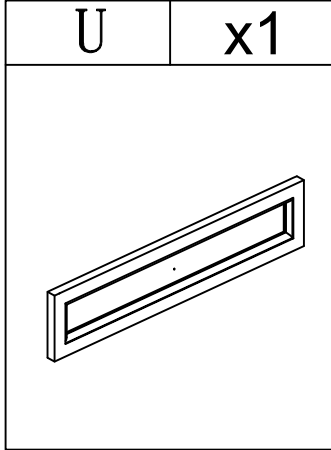
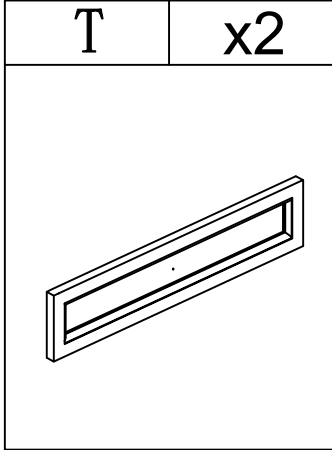
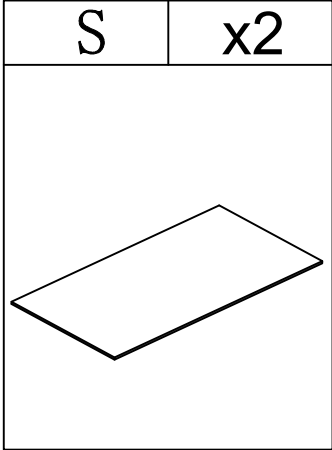
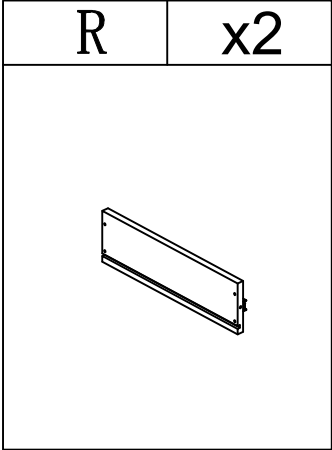

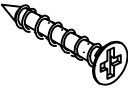

PARTS LIST 1



PARTS LIST 2



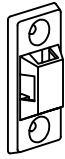

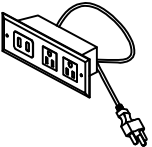
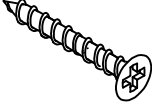
HARDWARE LIST

#1	x30	#2	x14	#3	x2	#4	x3	#5	x2	#6	x8
											
Ø4*25MM		Ø3*15MM		Ø3*20MM		Ø5/32"*18MM		Ø3*12MM		1/4"*2"	
#7	x1	#8	x3	#10	x2	#11	x2	#12	x1	#13	x1
											
Ø15*12MM		Ø27*22MM									
#16	x2										
											
Ø4*39MM											

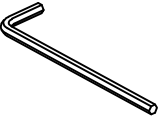
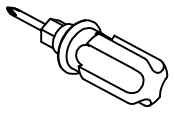
TOOL LIST

#14	x1	#15	x1
			
M6			

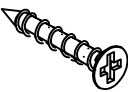
HARDWARE SPARE LIST

#1	x3	#2	x1	#6	x1
					
Ø4*25MM		Ø3*15MM		1/4"*2"	

ASSEMBLY INSTRUCTIONS

STEP-1

1. Insert part (G) into part (F), make sure all holes aligned and use screw #1 to attach them, tighten screw #1 with screwdriver #15.

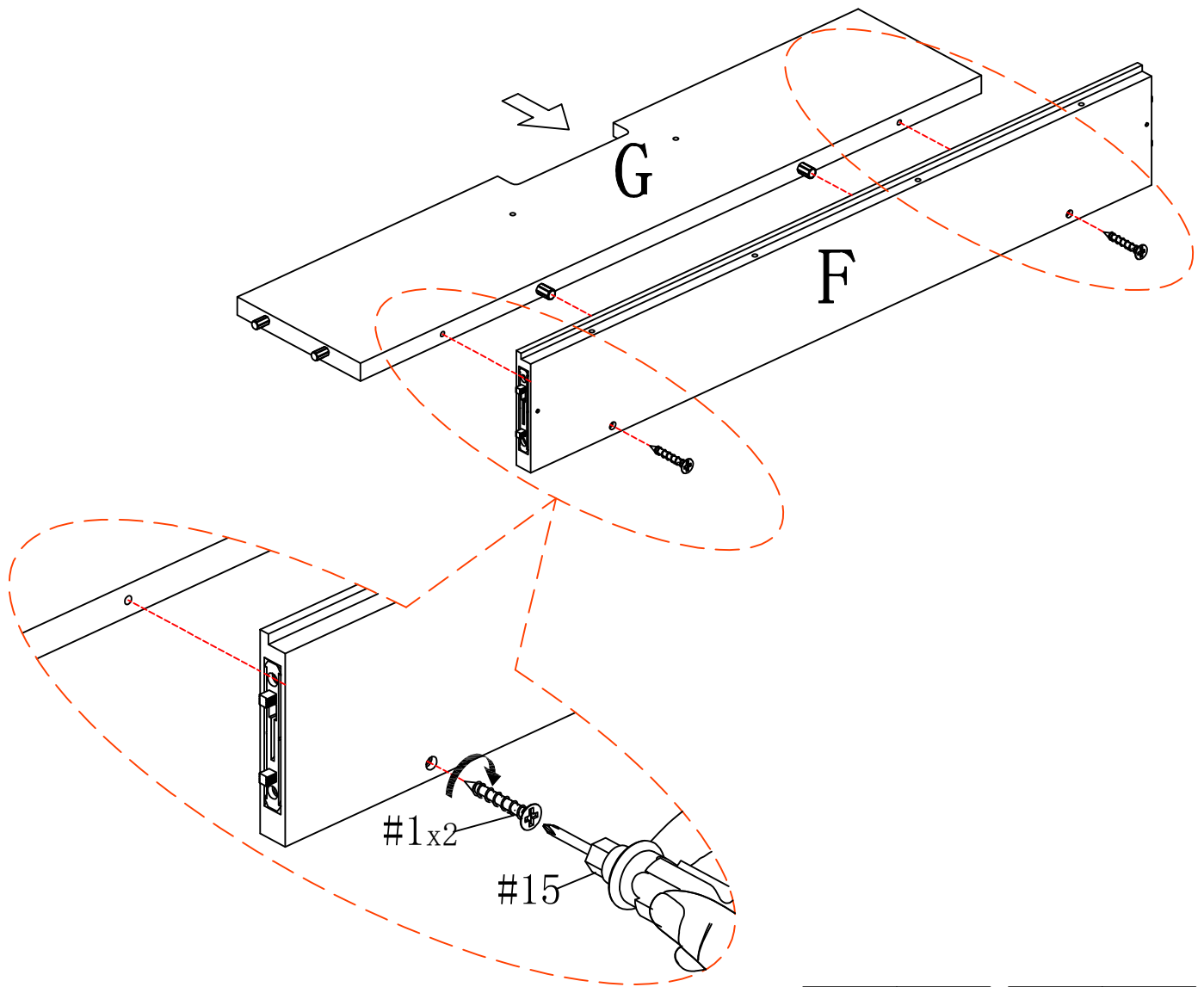

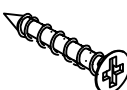
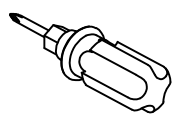
#1	x2	#15	x1
			
Ø4*25MM			

ASSEMBLY INSTRUCTIONS

STEP-2

1. Insert part (G&F&E) into part (C/D), make sure all holes aligned and then tighten it with allen key #14 as picture show.

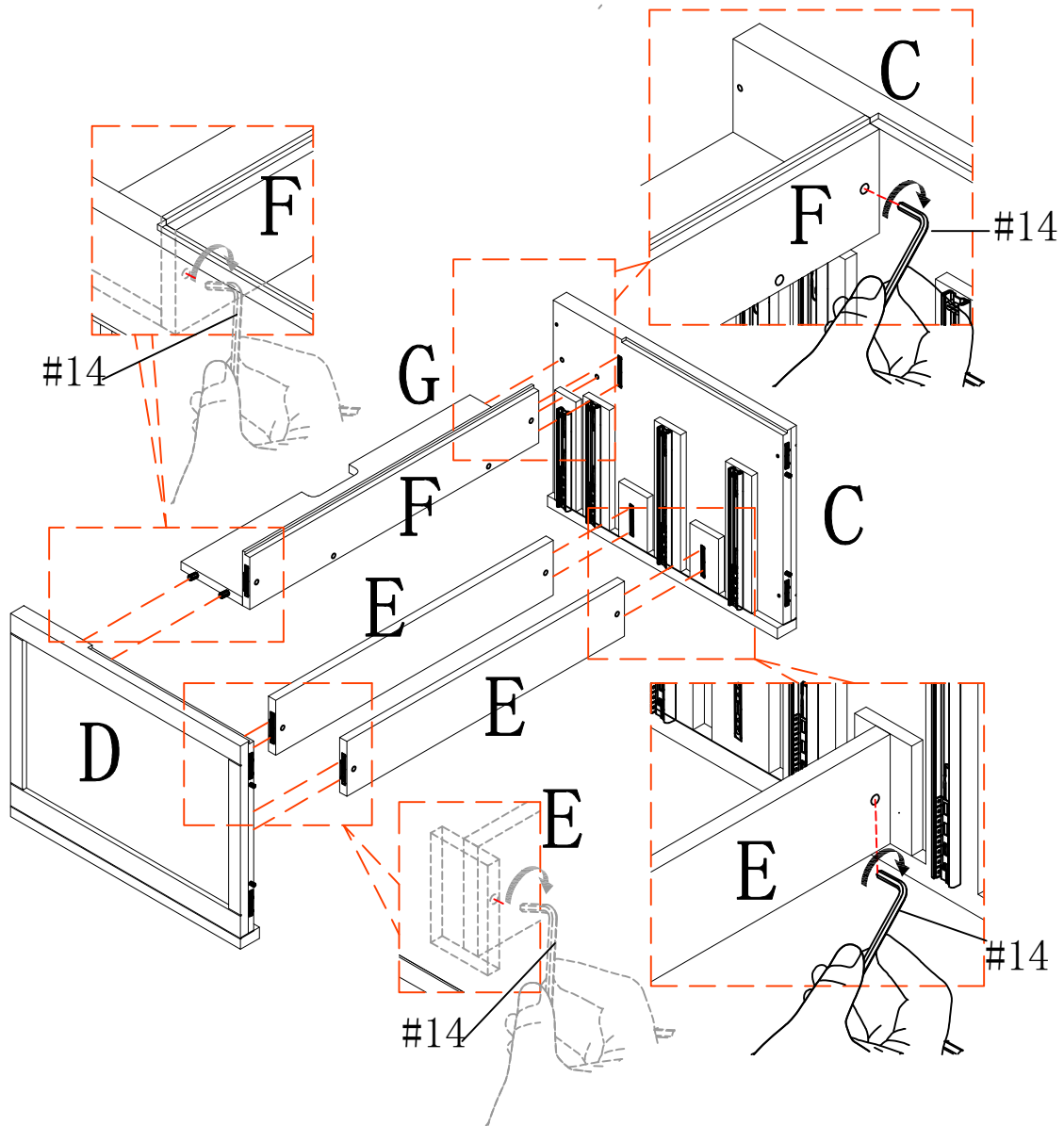

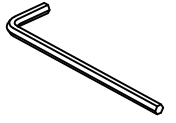

#14	x1
	
M6	

ASSEMBLY INSTRUCTIONS

STEP-3

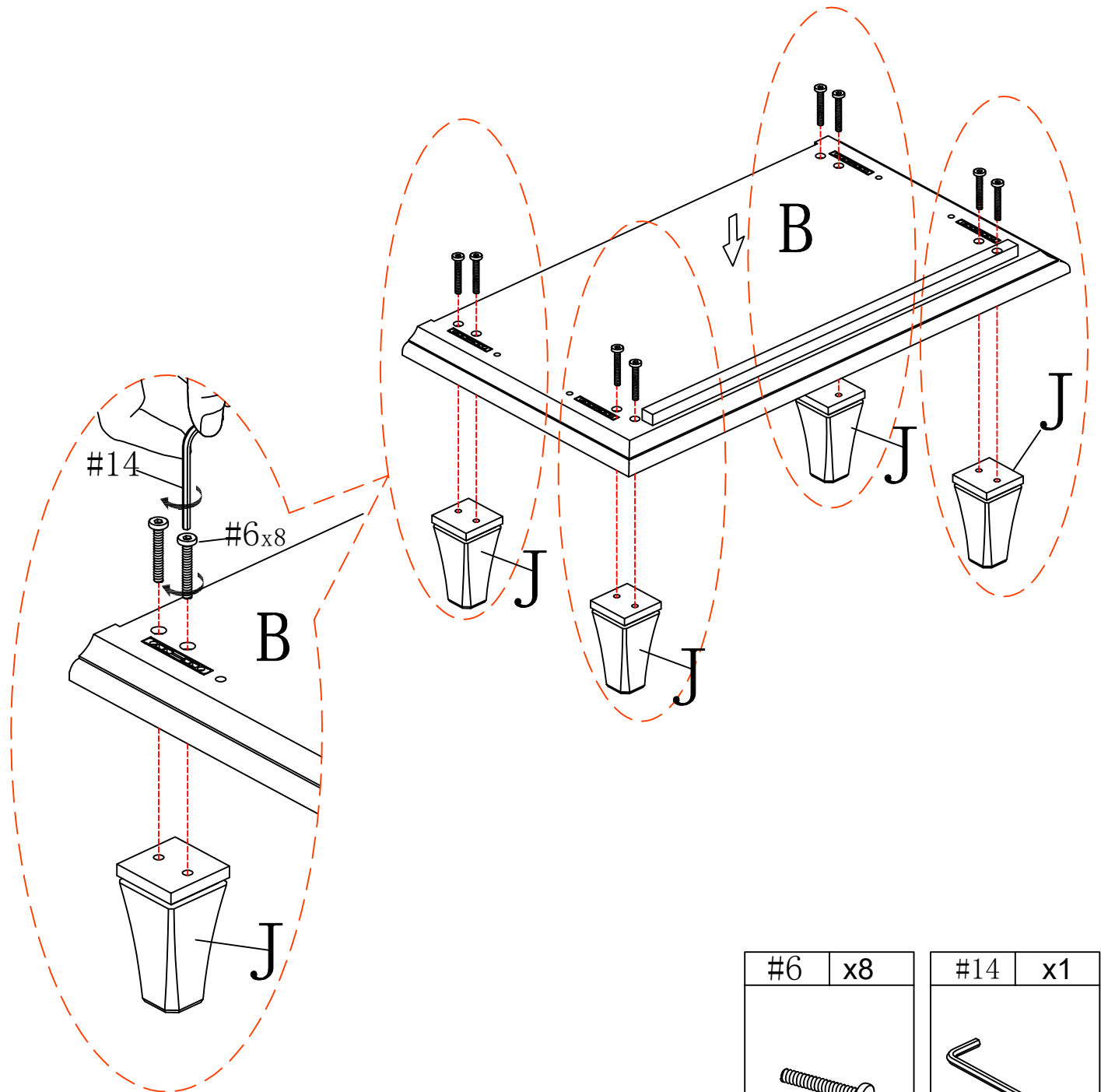
1. Insert screw #6, install leg (J) on of bottom panel (B), then tighten the screw with an Allen key #14.

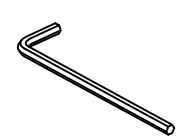

#6	x8	#14	x1
			
1/4"*2"		M6	

ASSEMBLY INSTRUCTIONS

STEP-4

1. Insert preassembled step 3 into the corresponding hole of bottom panel (B), make sure all holes aligned and use allen key #14 to tighten it as picture show.

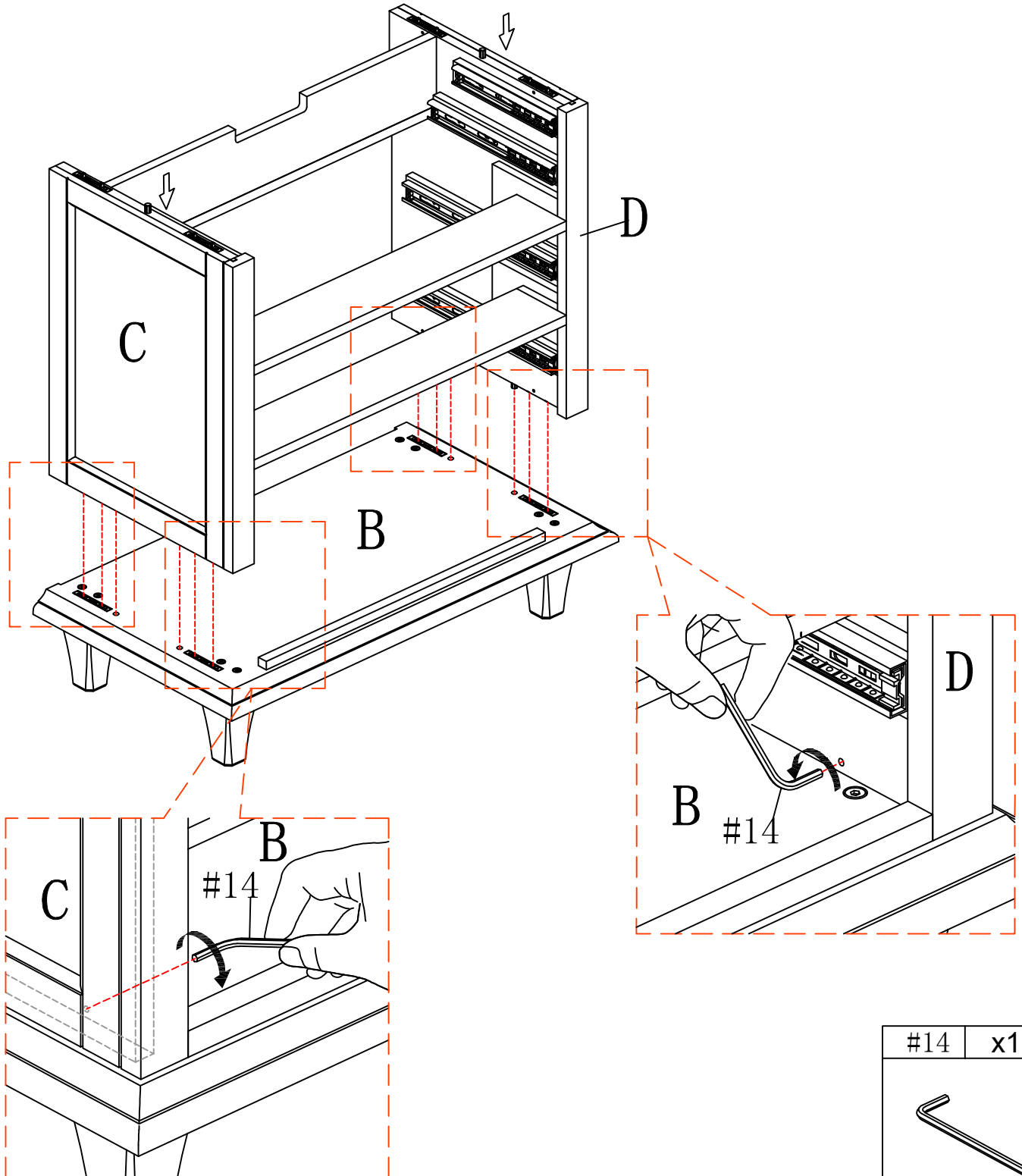

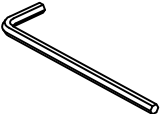
#14	x1
	
M6	

ASSEMBLY INSTRUCTIONS

STEP-5

1.insert back panel(I) into the groove of preassembled step 5,make sure all holes aligned and use screw #2 to attach them , tighten screw #2 with screwdriver#15.

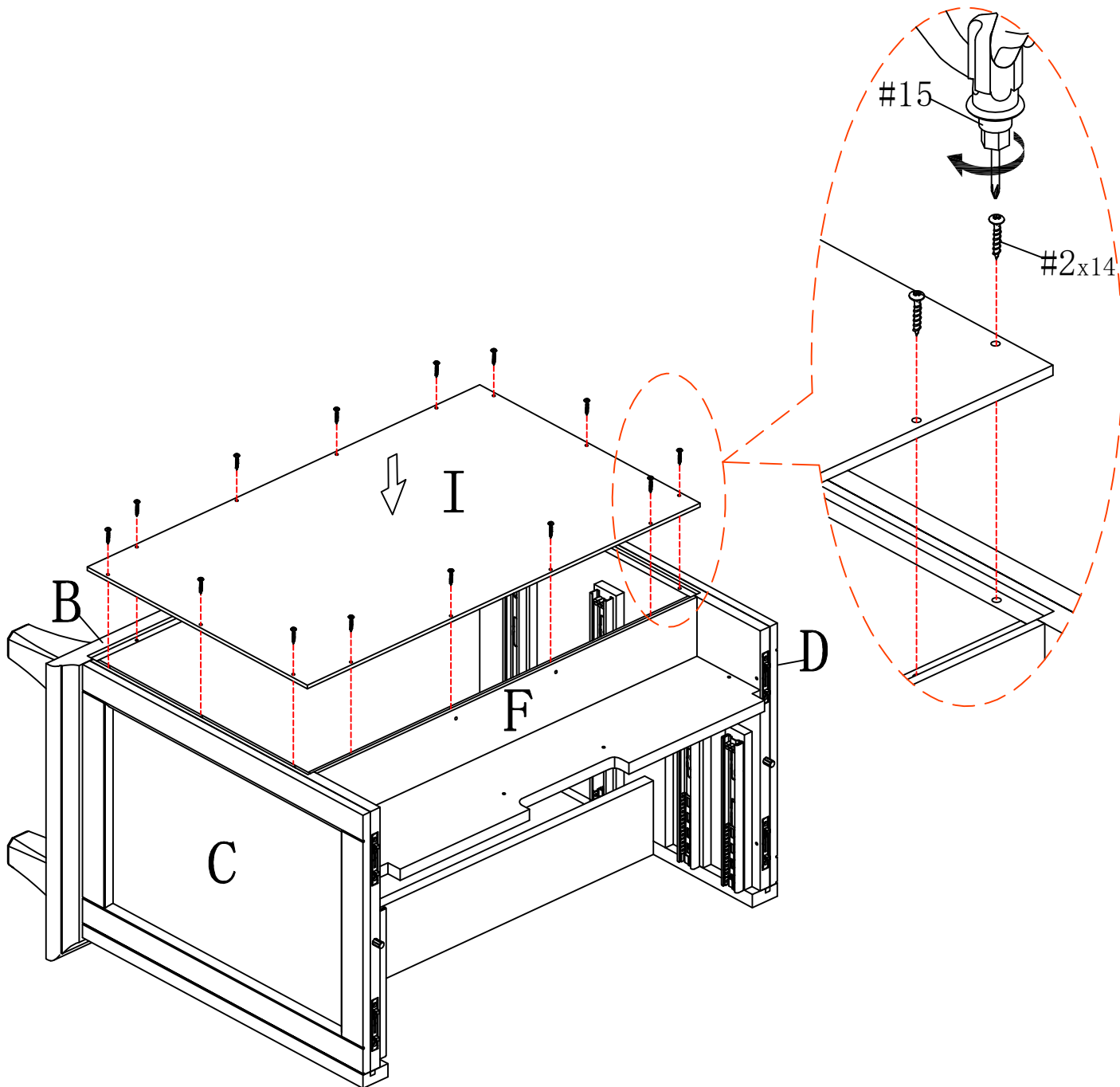

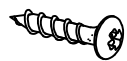
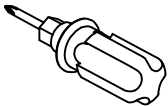
#2	x14	#15	x1
			
Ø3*15MM			

ASSEMBLY INSTRUCTIONS

STEP-6

1.insert part (H) into the preassembled step 6,make sure all holes aligned and use screw #1 to attach them , tighten screw #1 with screwdriver#15.

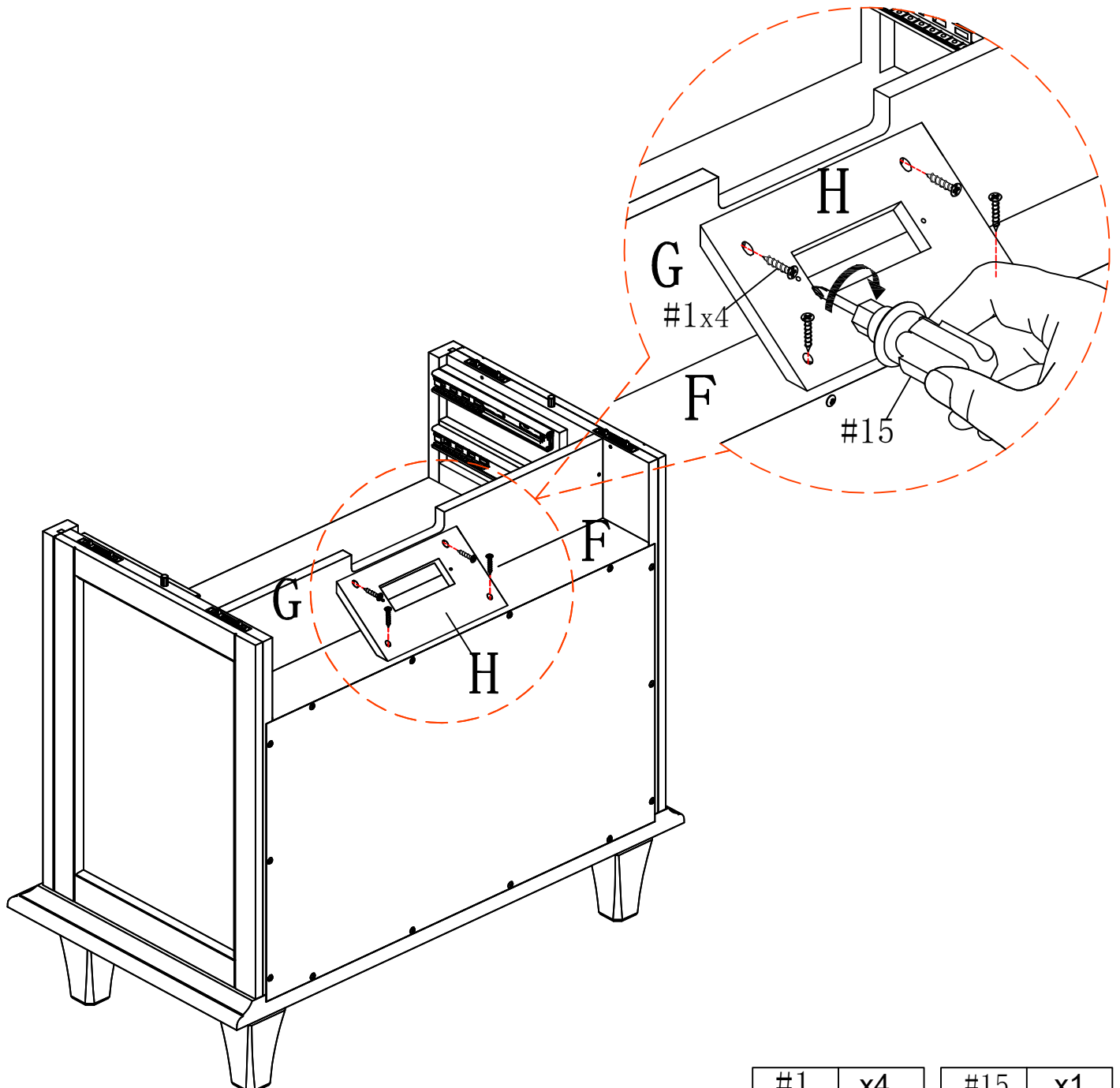

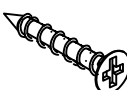
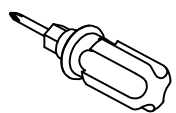

#1	x4	#15	x1
			
Ø4*25MM			

ASSEMBLY INSTRUCTIONS

STEP-7

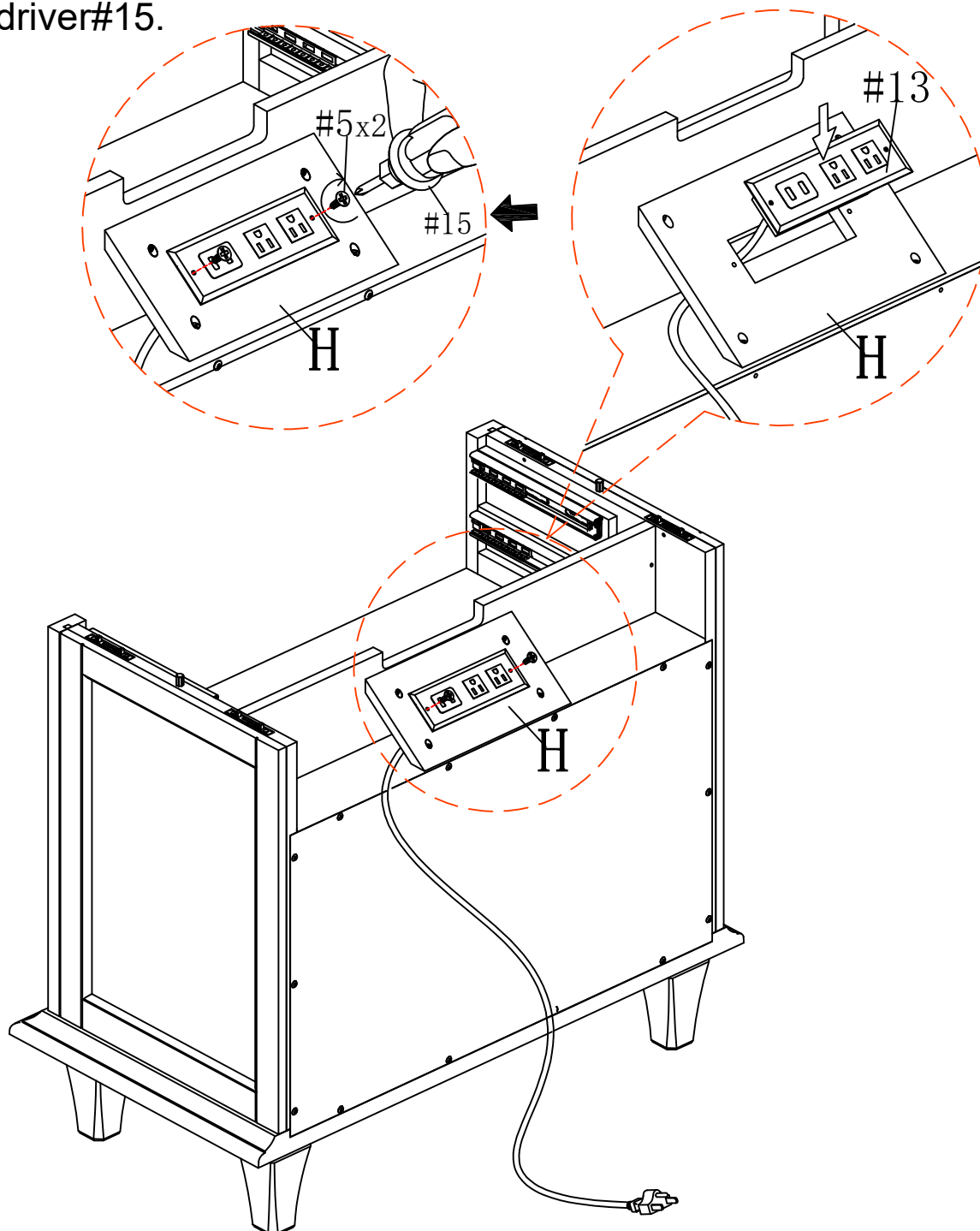
1.insert part #13 into the preassembled step 7,make sure all holes aligned and use screw #5 to attach them , tighten screw #5 with screwdriver#15.

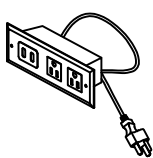

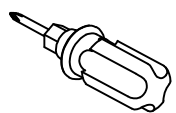
#13	x1	#5	x2	#15	x1
					
		Ø3*12MM			

ASSEMBLY INSTRUCTIONS

STEP-8

1. Insert top panel (A) into the corresponding hole of preassembled step 8 , make sure all holes aligned and use allen key #14 to tighten it as picture show.

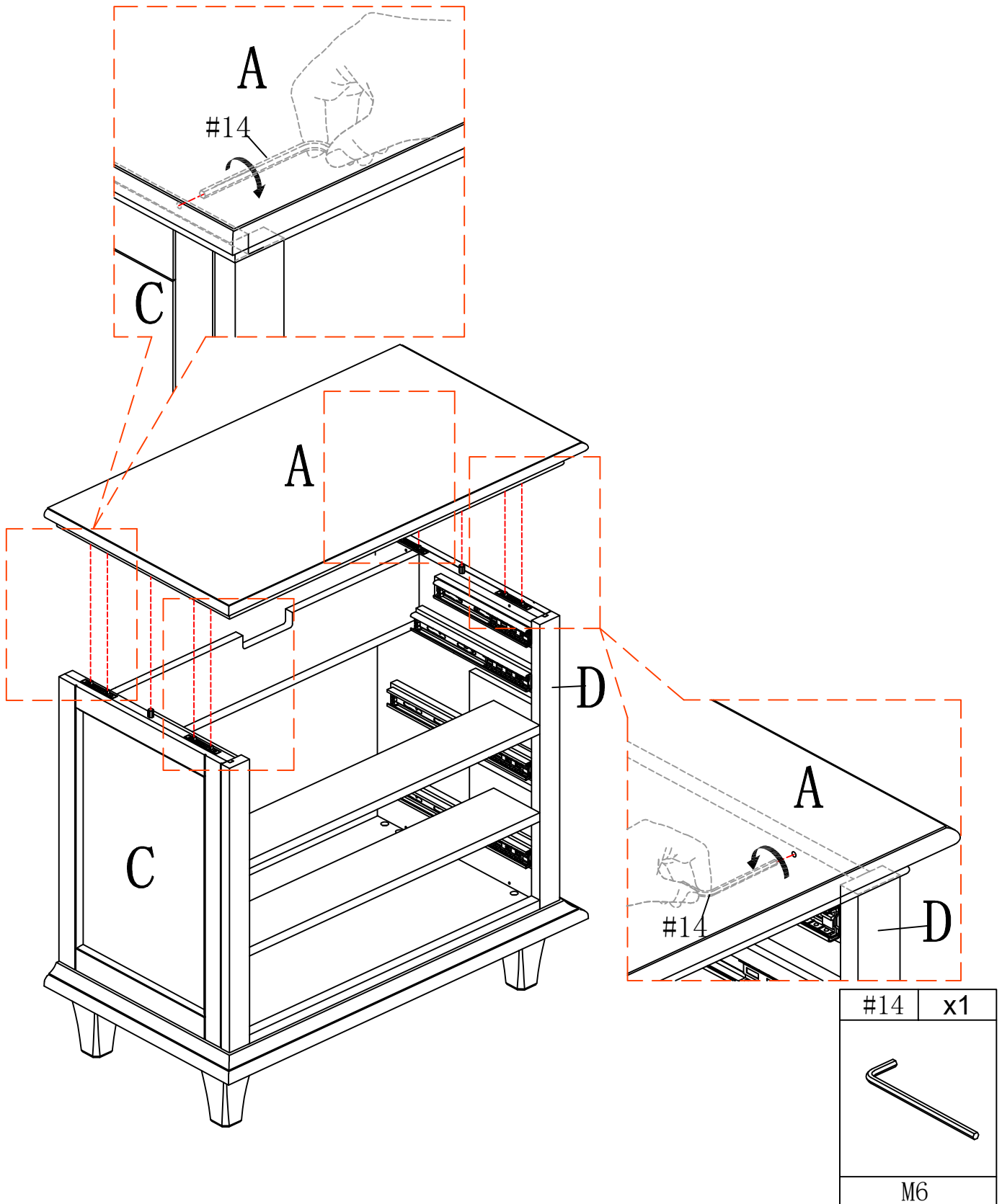

ASSEMBLY INSTRUCTIONS

STEP-9

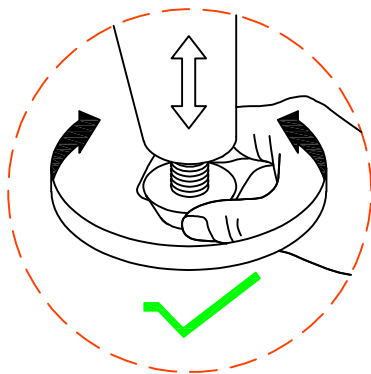
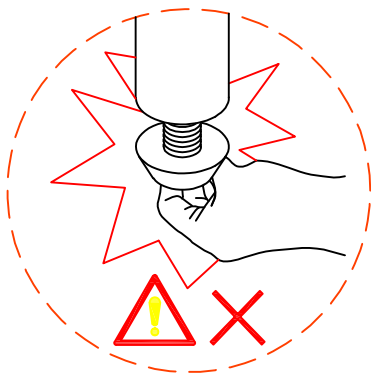
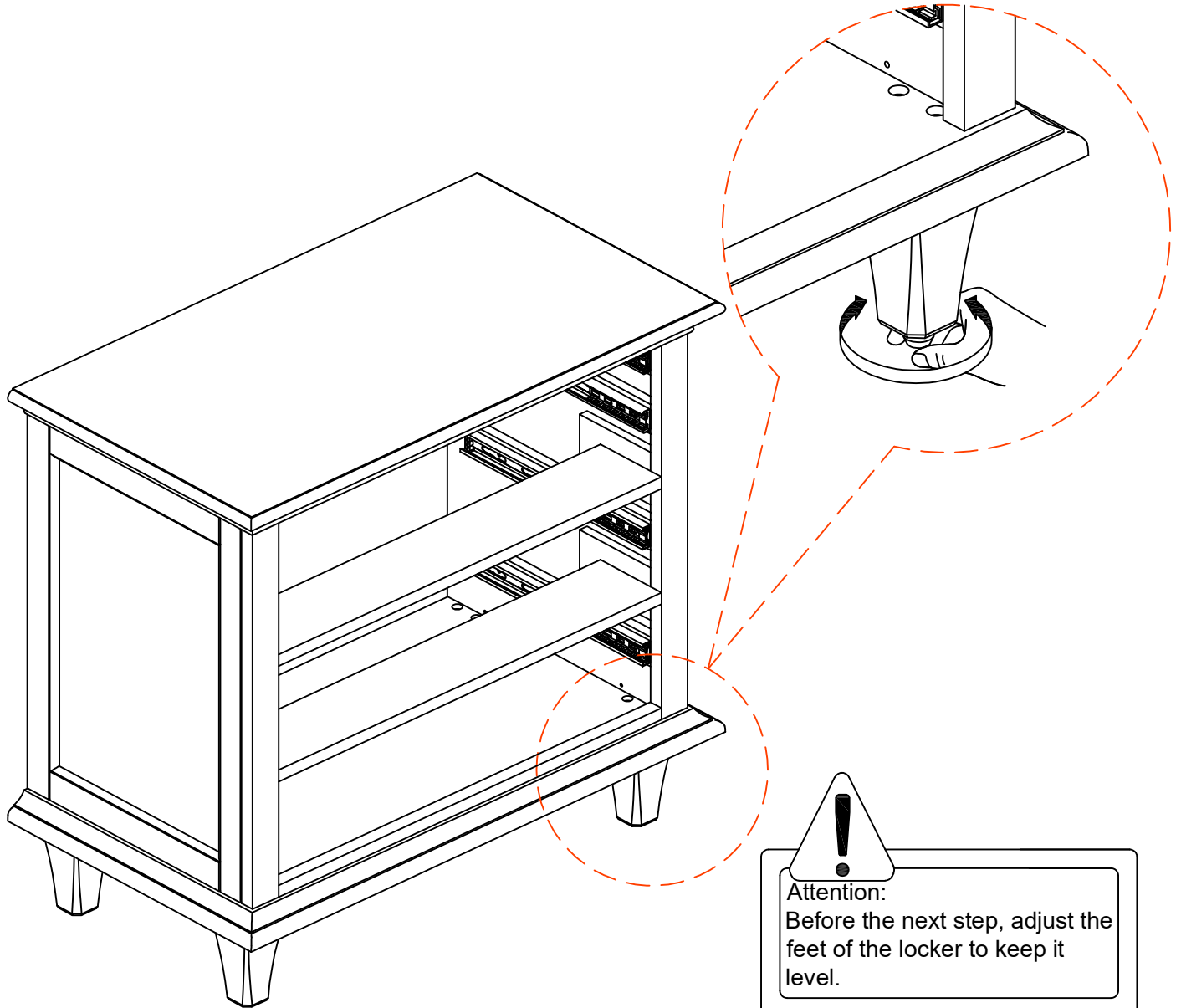

ASSEMBLY INSTRUCTIONS

STEP-10

1. Connect part (M&N) to part(U) using screw #1 and tighten it with screwdriver #15. Slide in the part (O) into the groove in part (M&N). make sure they are also in groove in part (U).

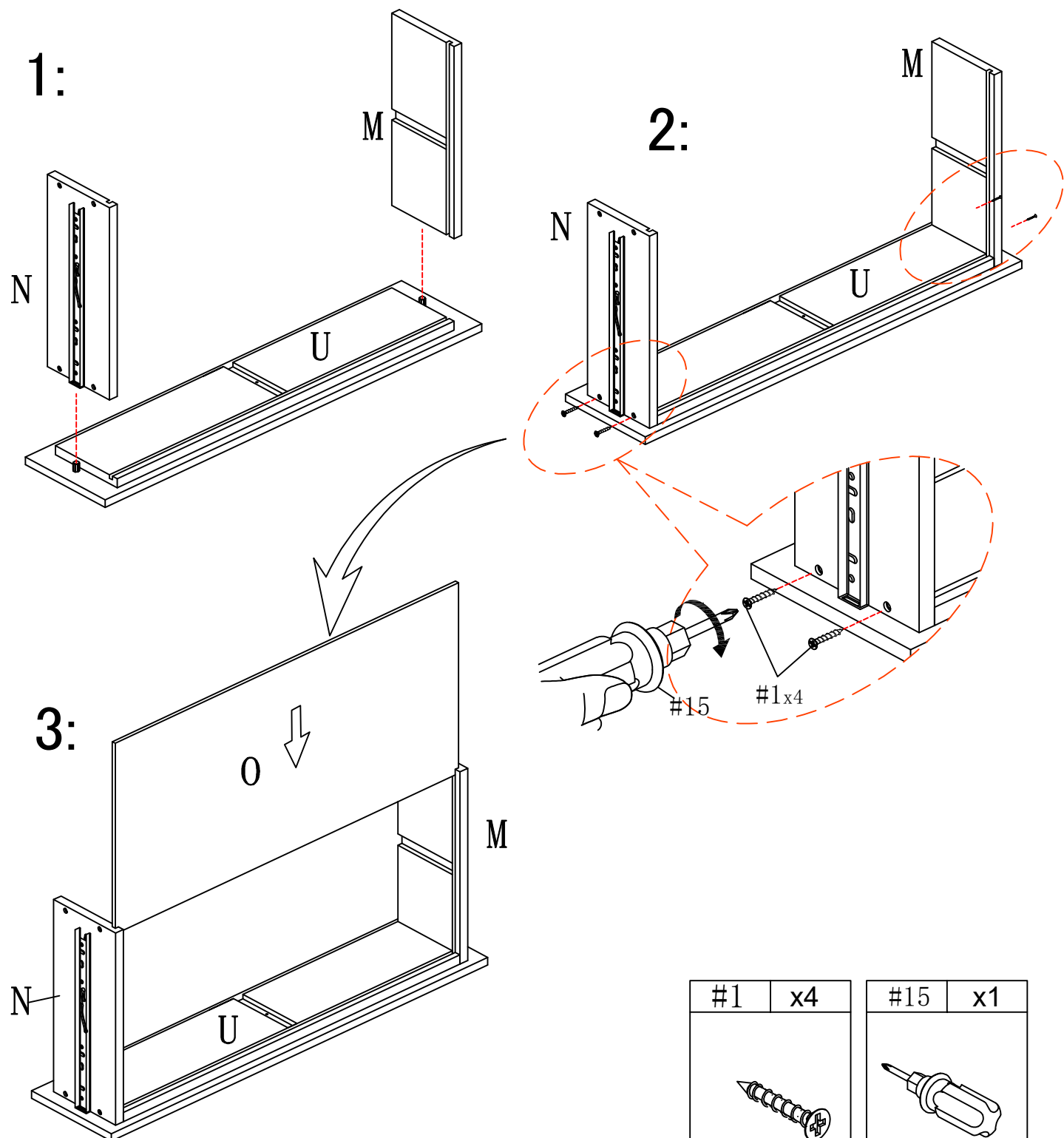

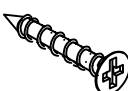
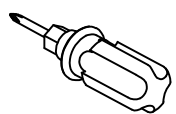

#1	x4	#15	x1
			
Ø4*25MM			

ASSEMBLY INSTRUCTIONS

STEP-11

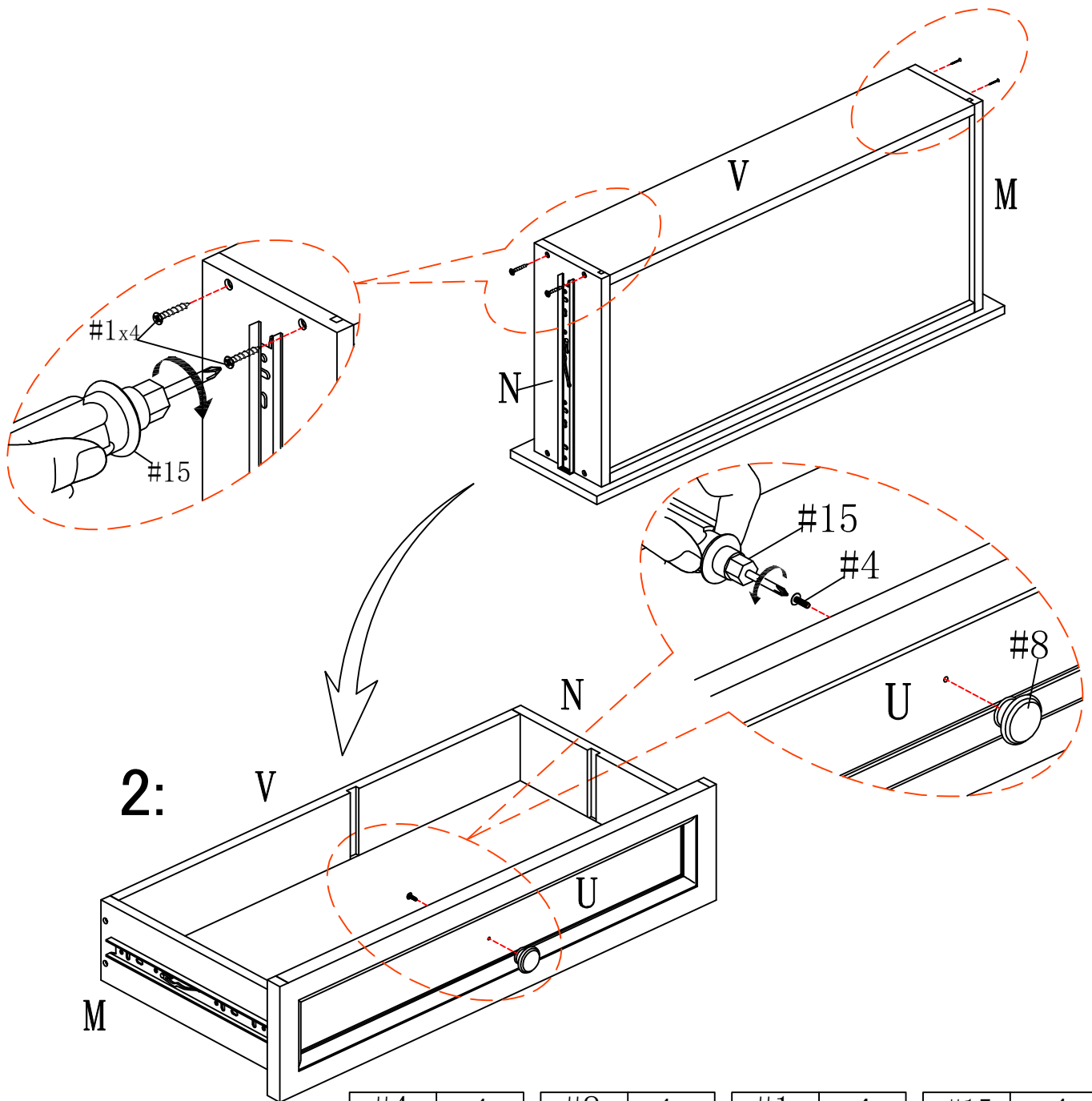
1. Connect the (V) and (M&N) using screw #1, and tighten it with screwdriver #15.
2. Install handle #8 to panel (U) using screw #4 and tighten it with screwdriver #15.

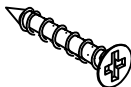
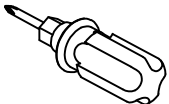

#4	x1	#8	x1	#1	x4	#15	x1
							
Ø5/32"*18MM		Ø27*22MM		Ø4*25MM			

ASSEMBLY INSTRUCTIONS

STEP-12

slide in the part (X) into the groove in part (V) . make sure it is also in groove in part (U).

slide in the part (Y) into the groove in part (X) . make sure it is also in groove in part (N).

slide in the part (Z) into the groove in part(Y) . make sure it is also in groove in part (U).

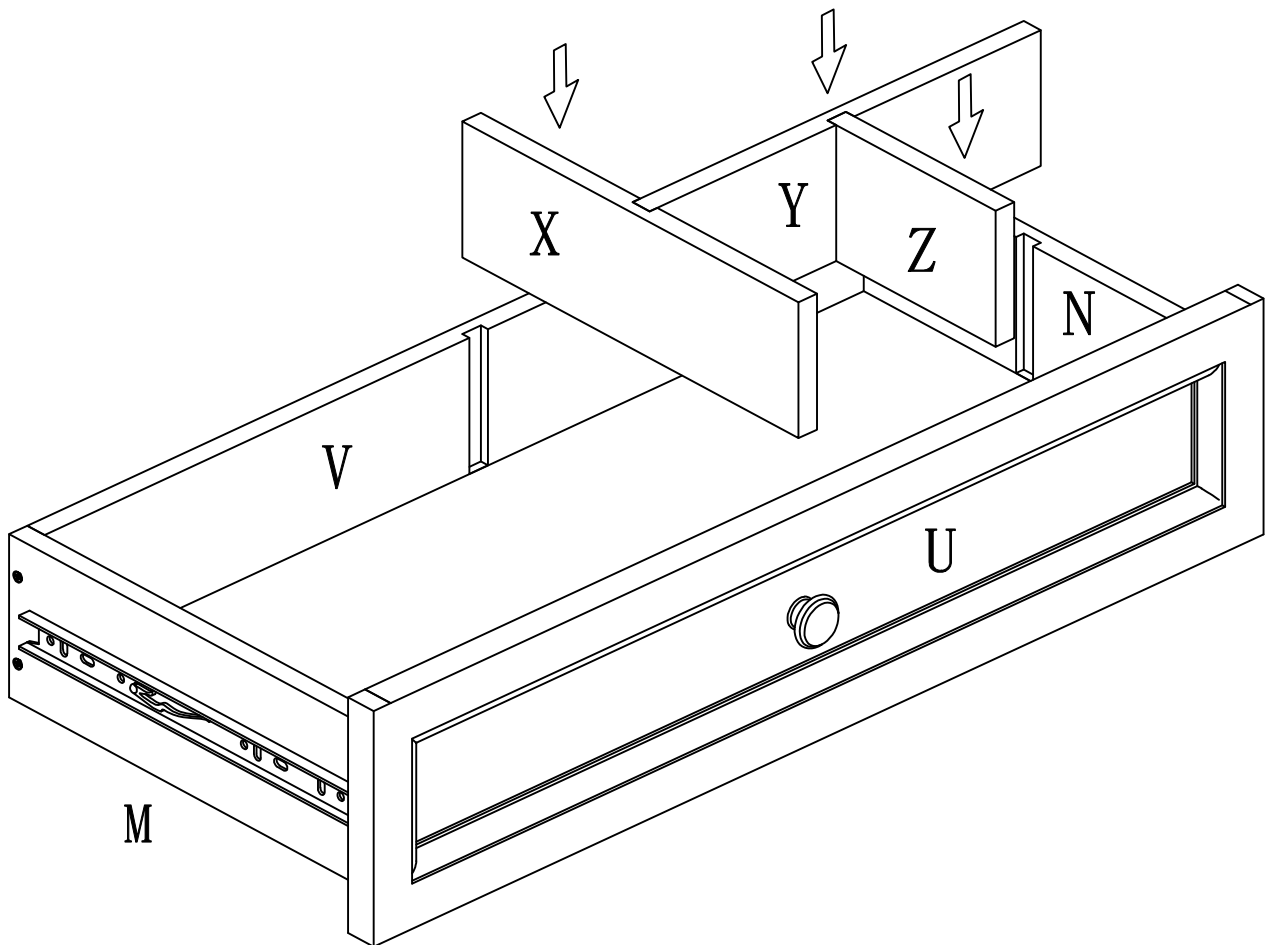

ASSEMBLY INSTRUCTIONS

STEP-13

1. Connect part (R&P) to part (T) using screw #1 and tighten it with screwdriver #15. Slide in the part (S) into the groove in part (R&P). make sure they are also in groove in part (T).

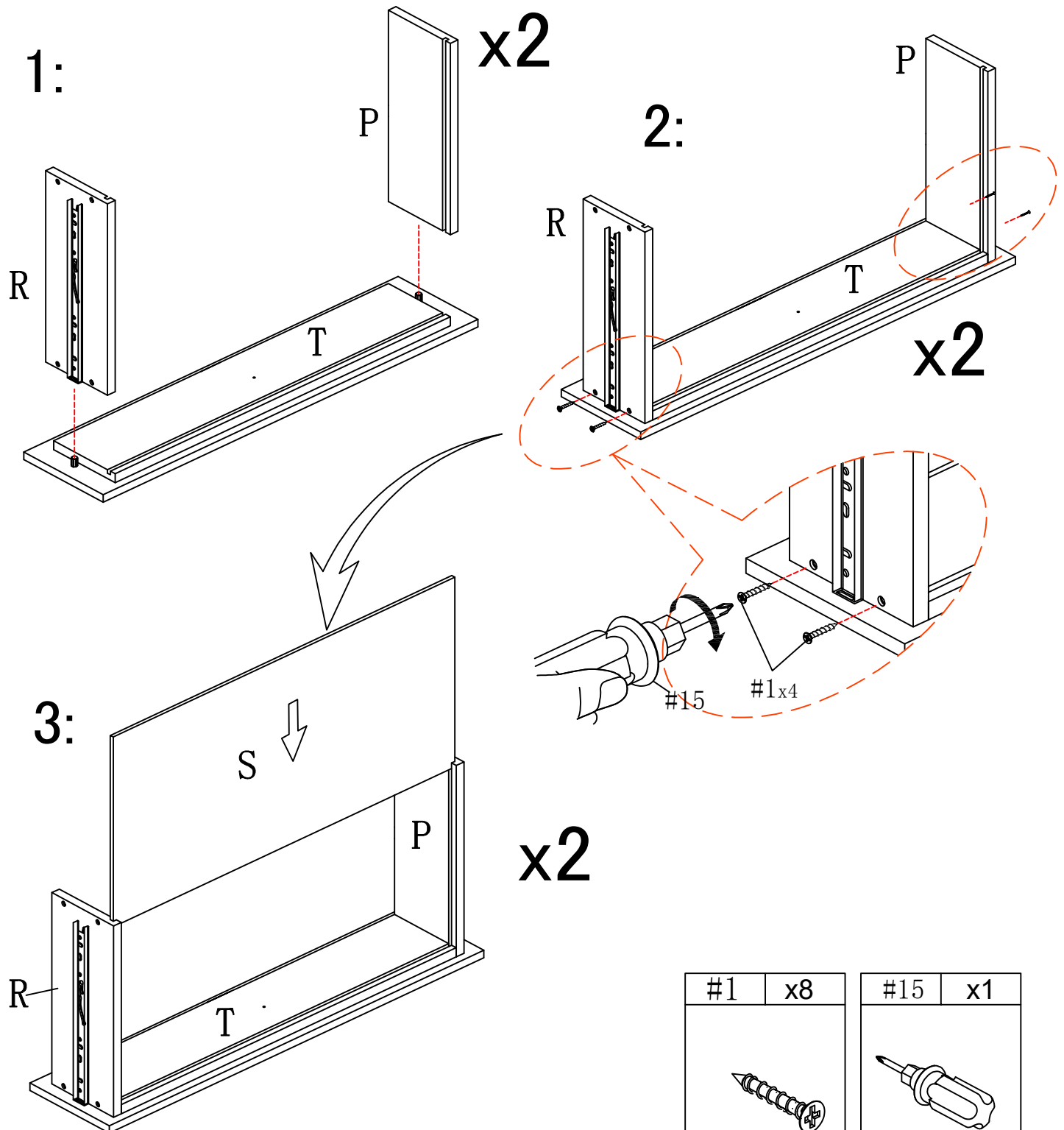

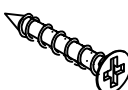
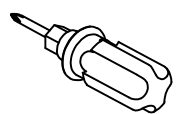

#1	x8	#15	x1
			
Ø4*25MM			

ASSEMBLY INSTRUCTIONS

STEP-14

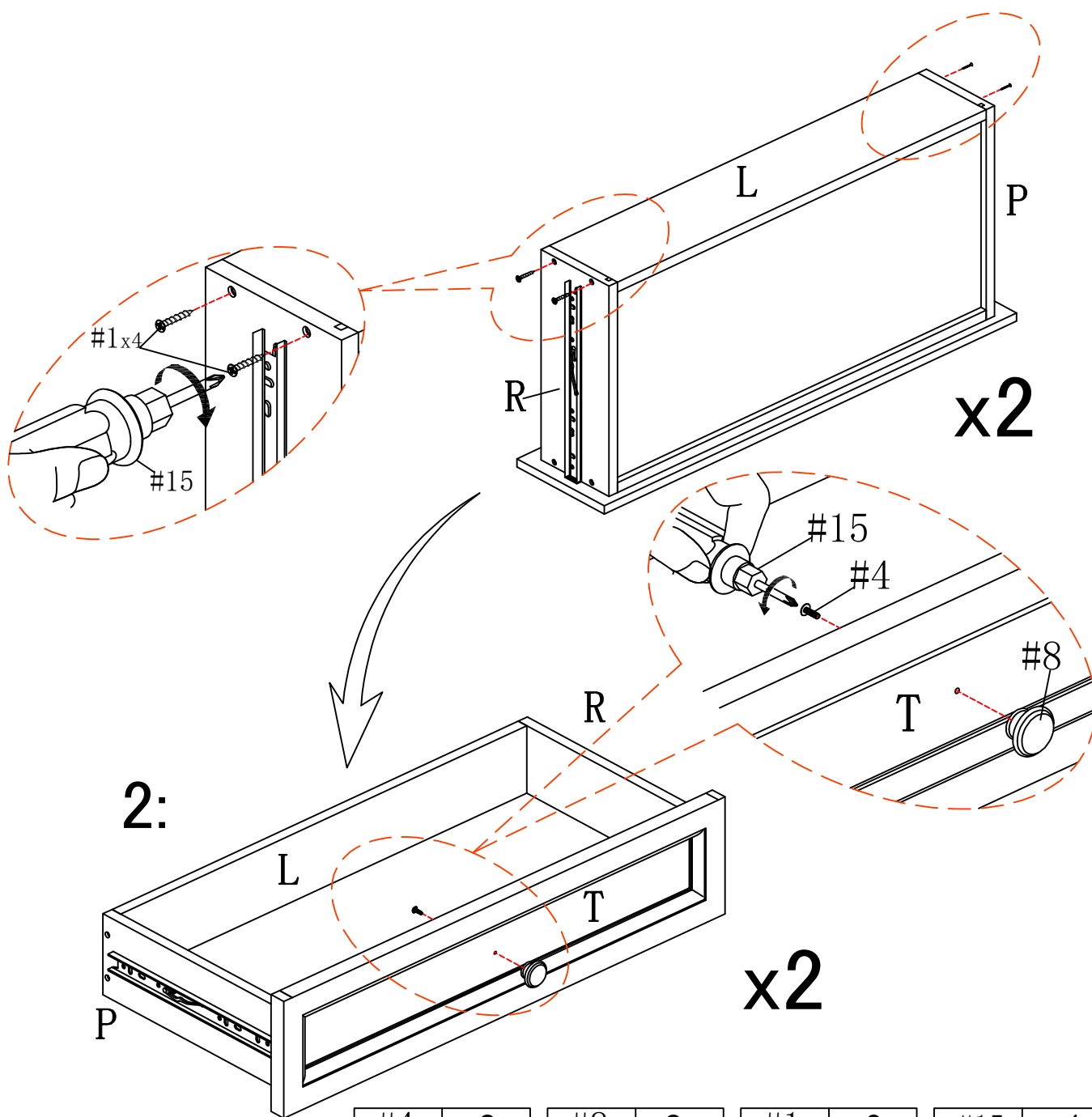
1. Connect the (L) and (R&P) using screw #1, and tighten it with screwdriver #15.
2. Install handle #8 to panel (T) using screw #4 and tighten it with screwdriver #15.

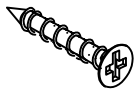
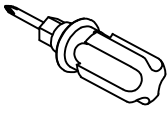

#4	x2	#8	x2	#1	x8	#15	x1
							
Ø5/32"*18MM		Ø27*22MM		Ø4*25MM			

ASSEMBLY INSTRUCTIONS

STEP-15

1. Install #7 handle clockwise onto panel (K).

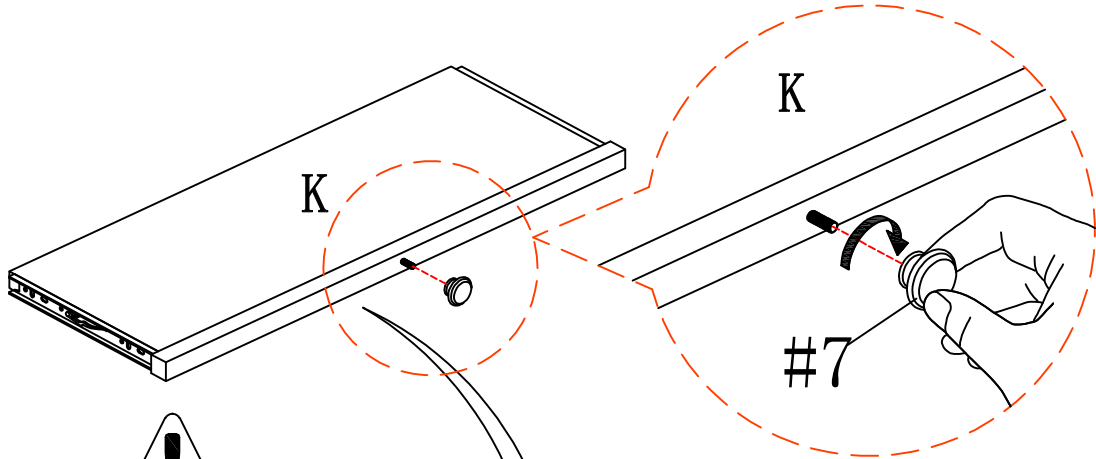

!
Attention: When installing the drawer, slide the steel ball slide rail of side panel to the most front as picture show.

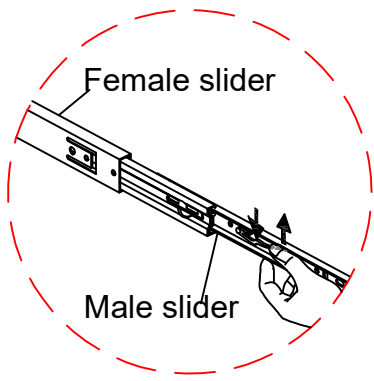

Schematic diagram of slide rail disassembly

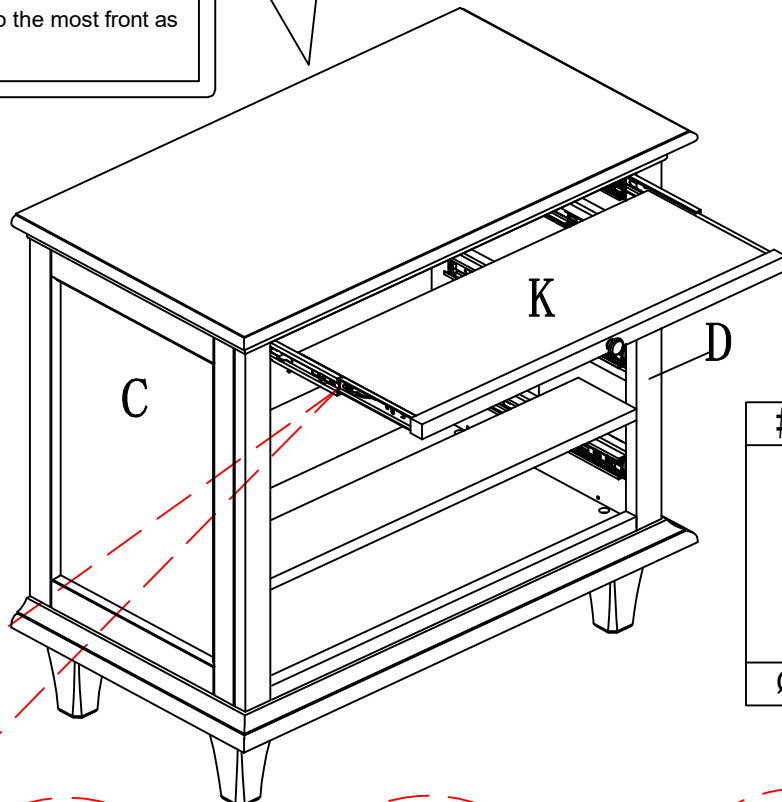

#7	x1
Ø15*12MM	

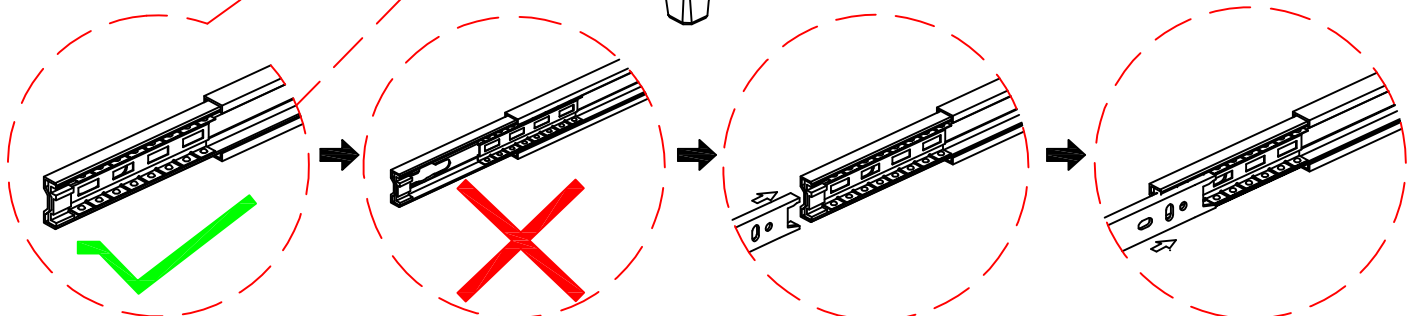

ASSEMBLY INSTRUCTIONS

STEP-16

1. Install drawer (U/T) to the body as picture.

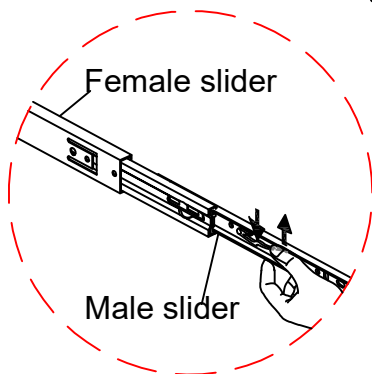
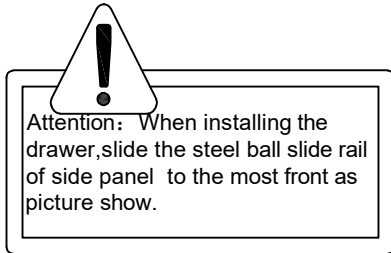

Schematic diagram of slide rail disassembly

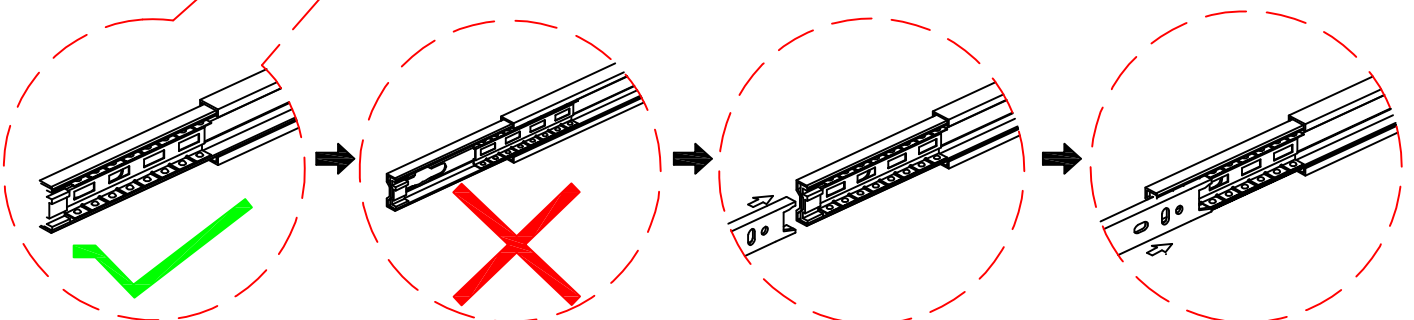
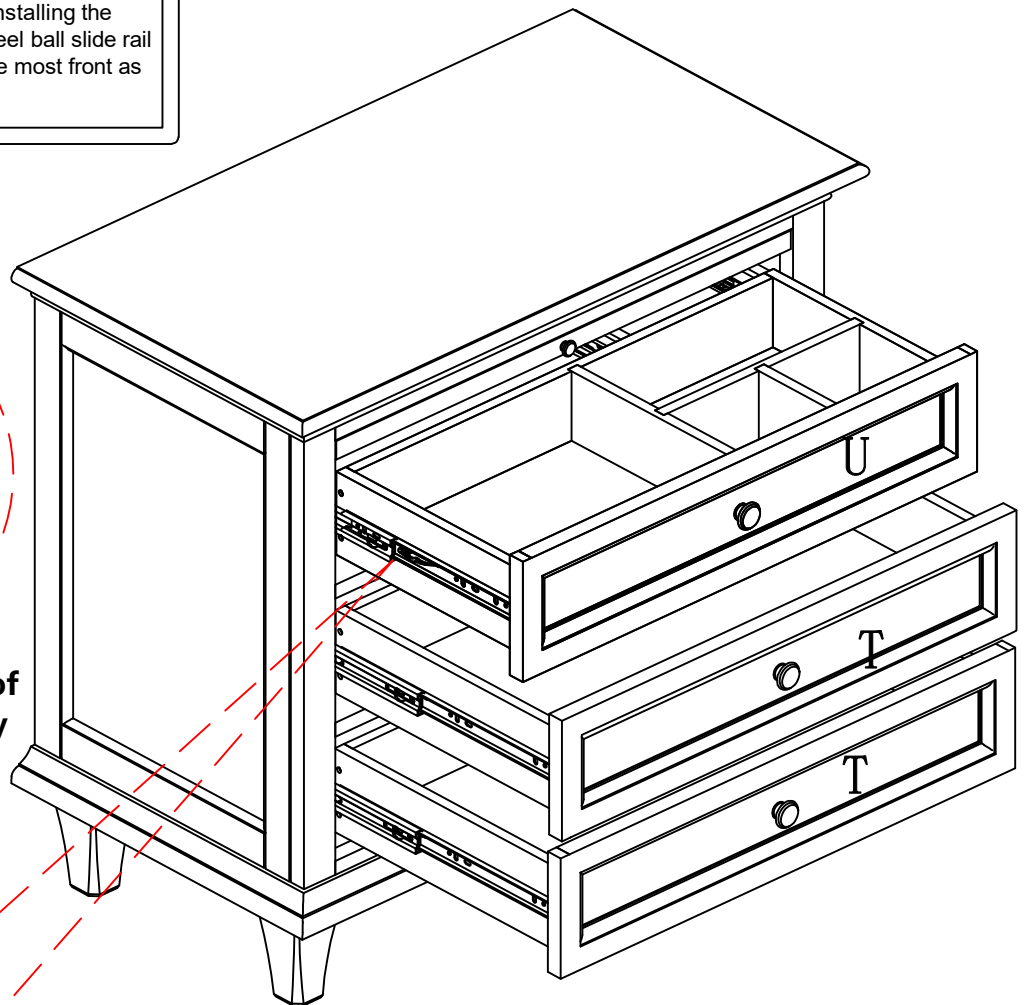



ASSEMBLY INSTRUCTIONS

STEP-17

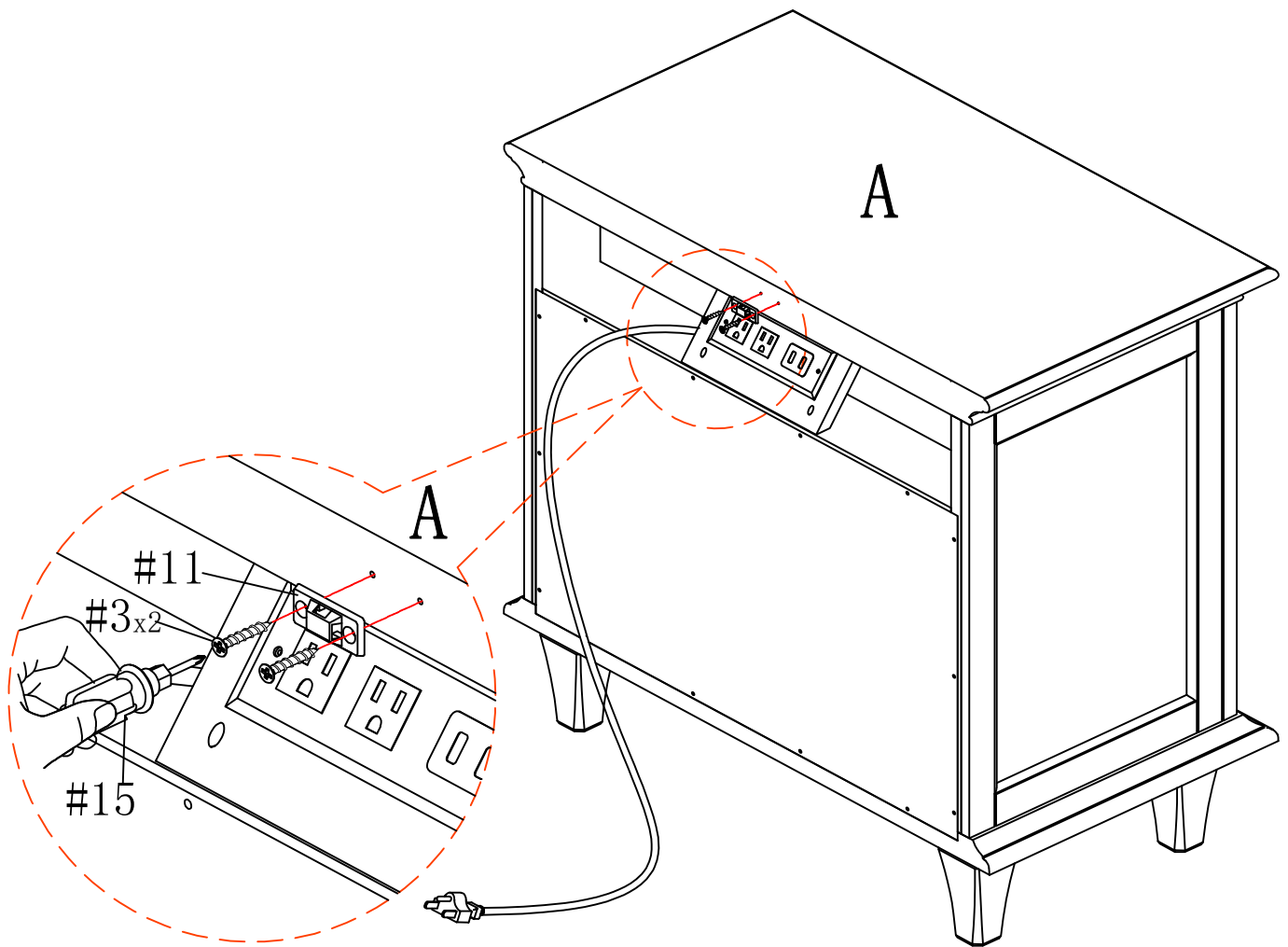

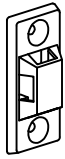
1. Use screw #3 to attach part #11 to top panel (A), tighten screw #3 with screwdriver #15.

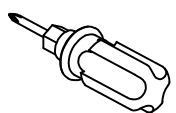

#11	x1	#3	x2	#15	x1
					
		Ø3*20MM			

ASSEMBLY INSTRUCTIONS

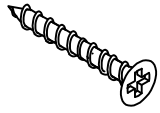
STEP-18

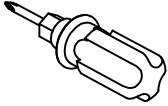
#16	x2	#10	x2	#11	x1	#15	x1
							
Ø4*39MM							

1. Install the anti-collapse device.
2. Mark the position on the wall, that corresponds to the location of part #11 on the top of panel (A); Drill and insert the expandable screw #10 by hammer.
3. Assemble the part #11 to the wall. Align the hole in the part #11 with the expandable screw #10, use screw #16 to attach it and tighten by screwdriver #15.

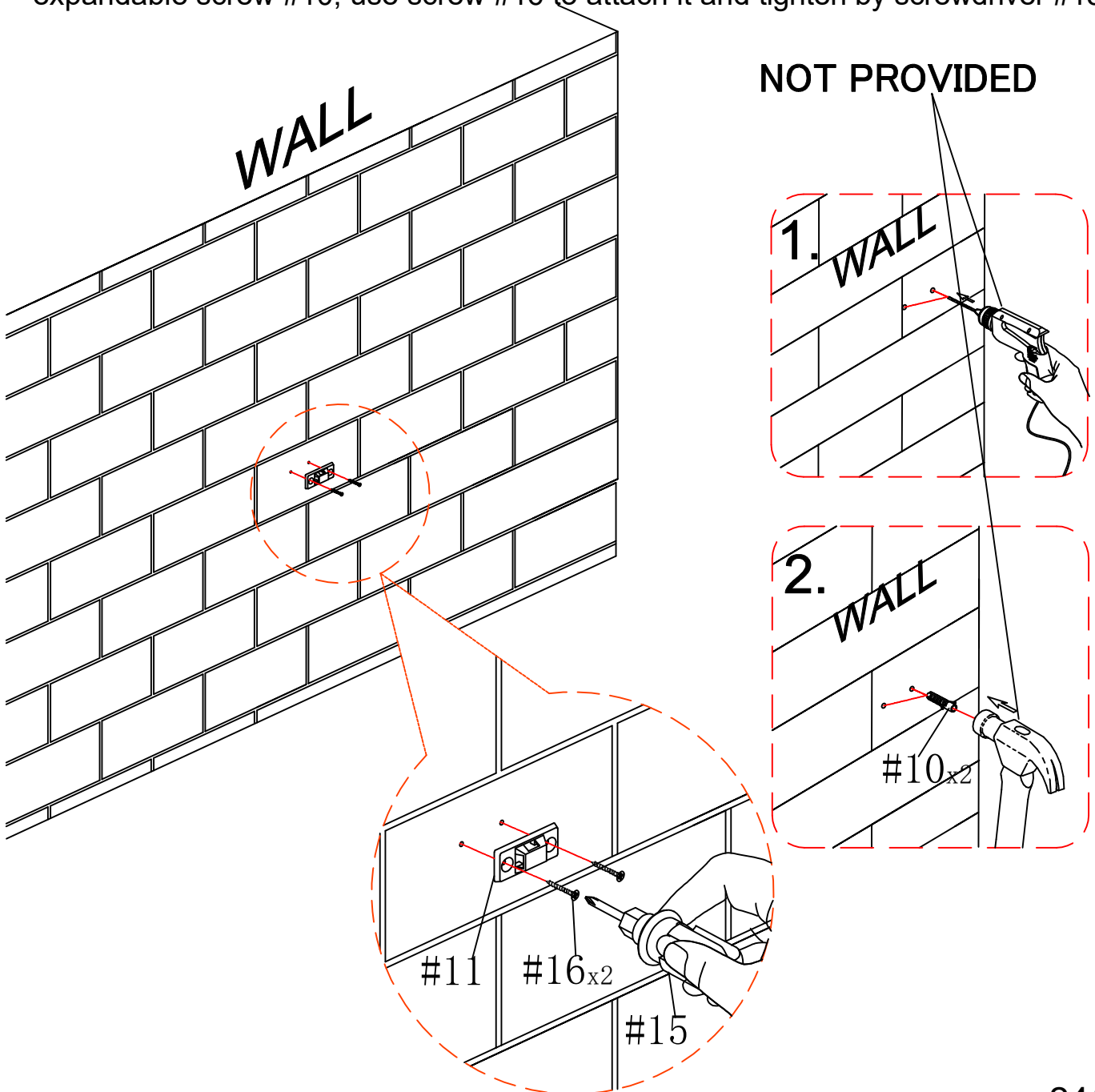

ASSEMBLY INSTRUCTIONS

STEP-19

1. Let the plastic belt #12 pass through the both part #10 and pull tightly.

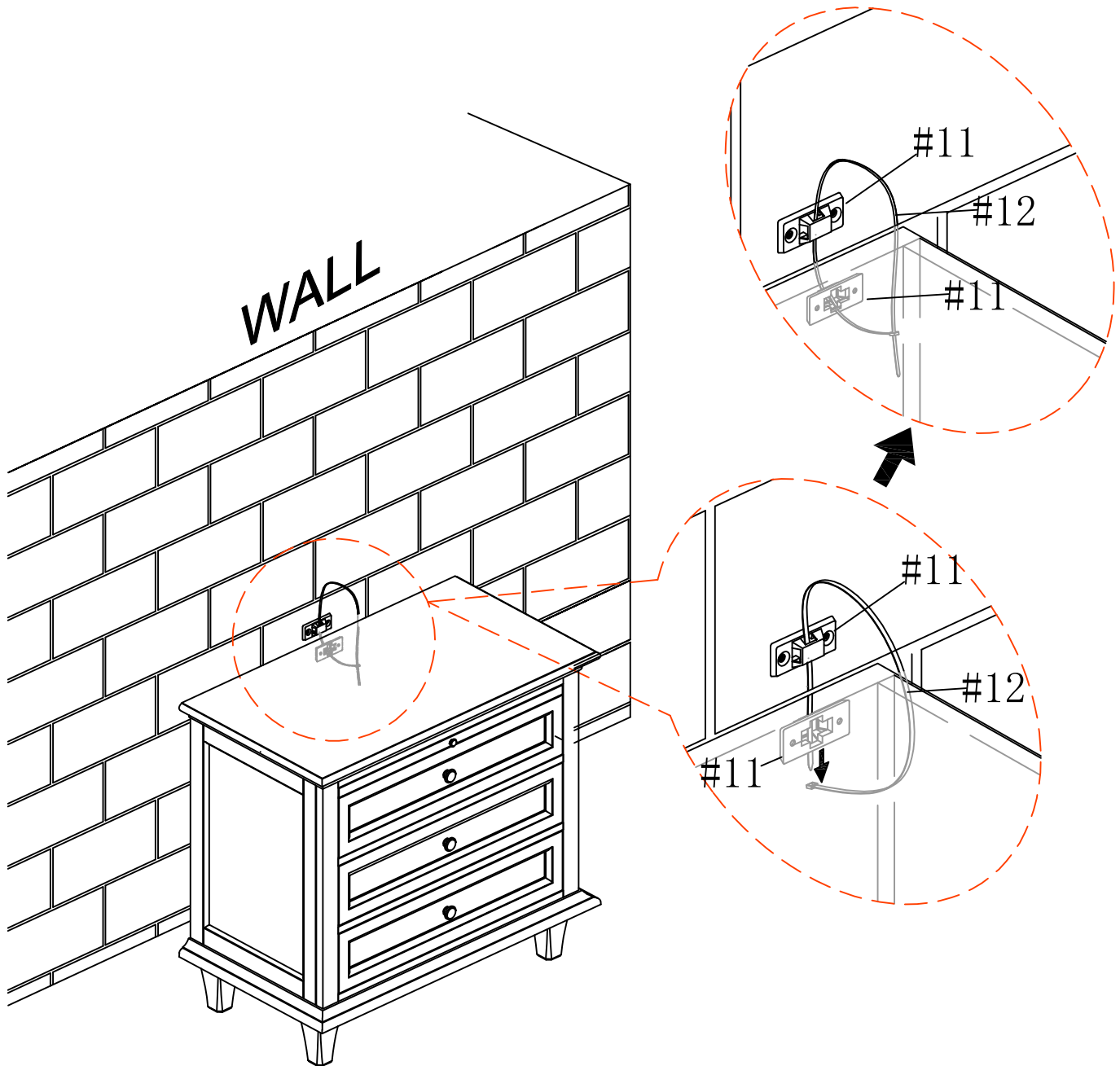
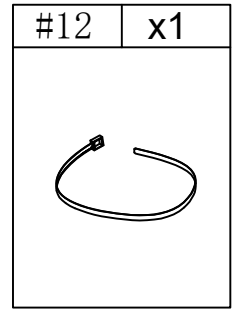

WARRANTY

1. We strive to offer high-quality products, and we also try our best to satisfy each and every customer that orders from us with product or service as needed.
2. We provide 30 days warranty starting from the time you receive the item. Each customer must provide a record of their order such as the order number, or item receipt for any items that are out of the warranty period you may also still receive.
3. Replacement parts by purchasing them with our company if they are available.