

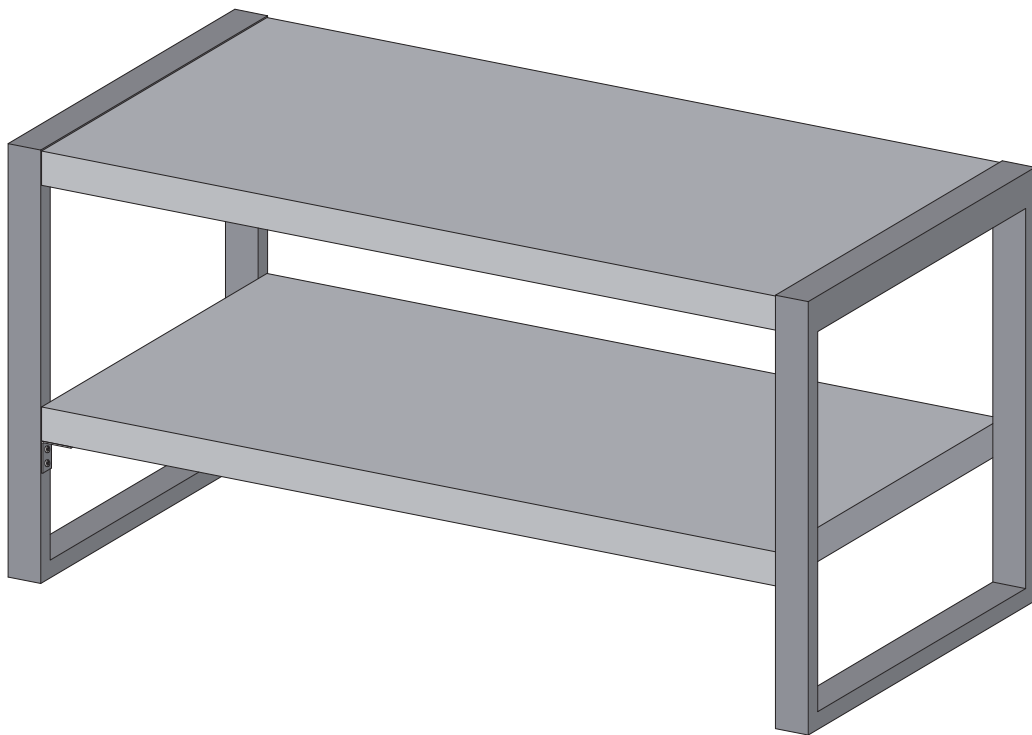

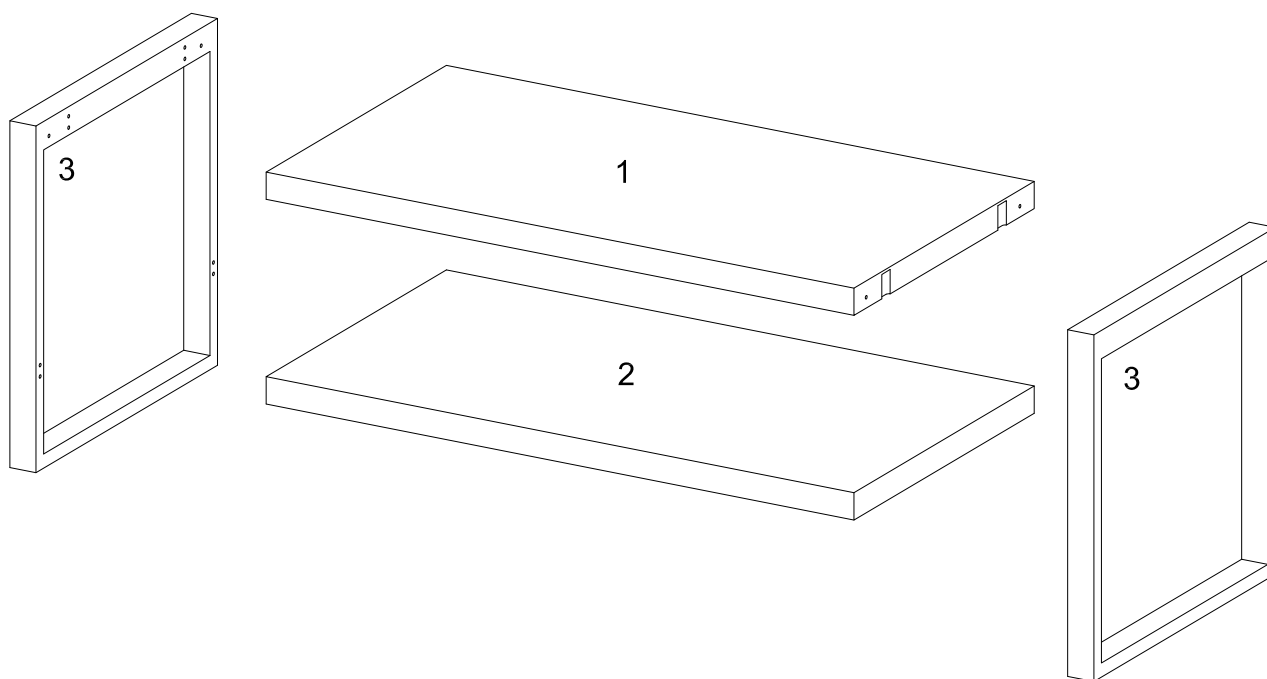



Assembly Instructions



Parts List



Hardware List

A		M6*12mm	Bolts	32 pcs
B			L-shape connector	8 pcs
C		M6*60mm	Bolts	4 pcs
D			Washer	4 pcs
E		M6	Wrench	1 pc

*The hardware quantities listed above are required for proper assembly.
Some extra hardware may also have been included.*

Step 1

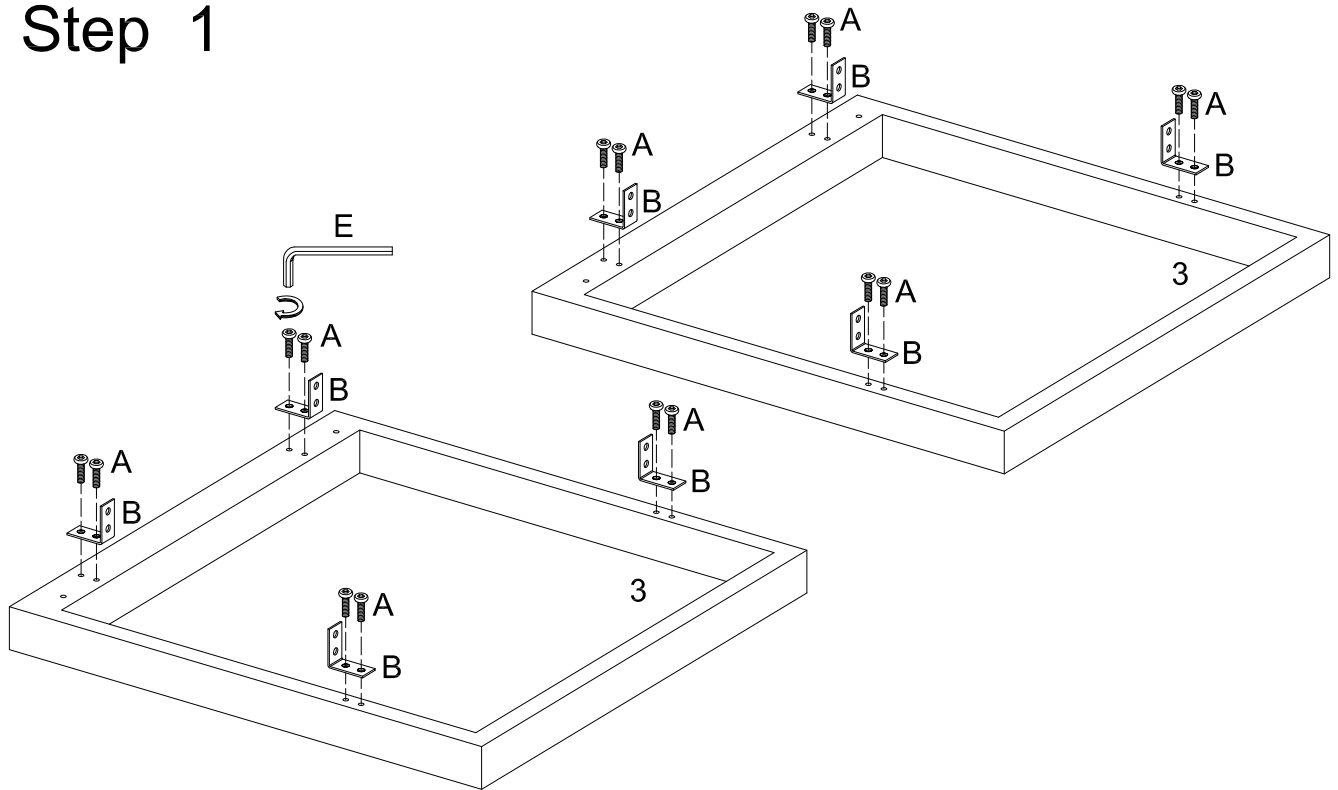

Place the Metal Frames (3) on the flat Surface, attached the L-shape connector (B) with the Bolts (A) and Wrench (E) as per diagram.

Step 2

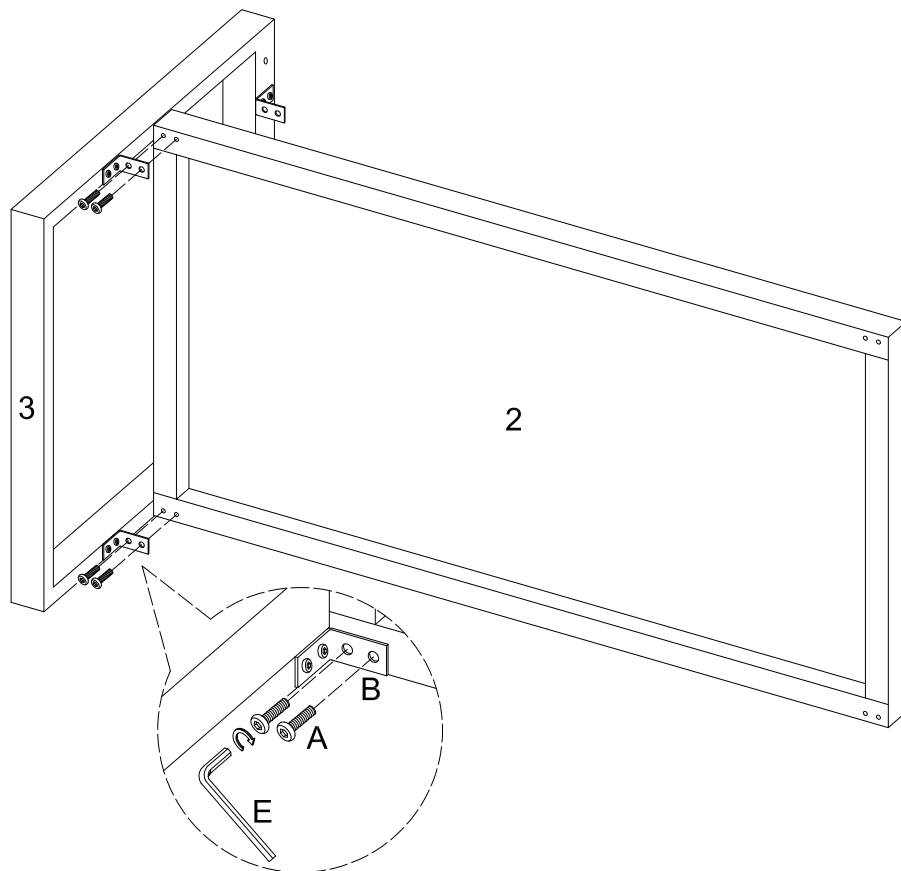

Attach the Lower Wooden Panel (2) to the Metal Frame (3) with Bolts (A), L-Shape Connector (B) and Wrench (E) for one side.

Step 3

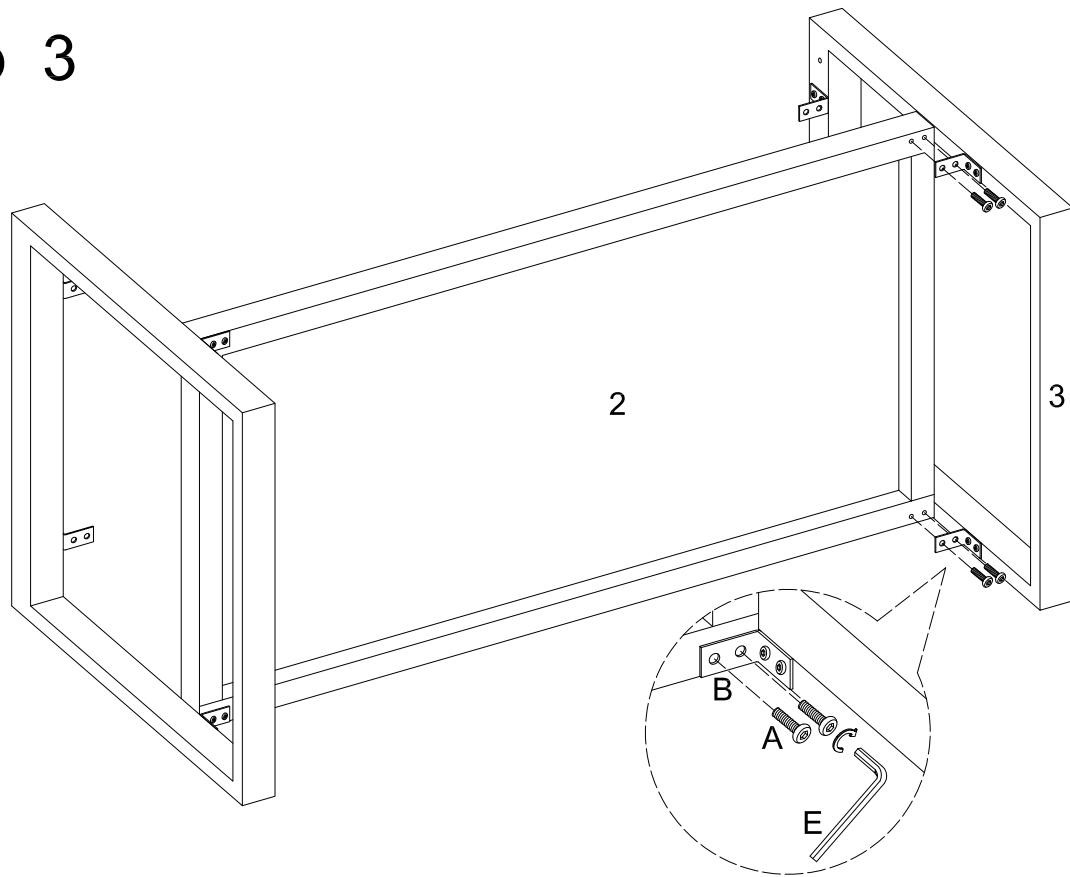

Repeat Step #2 for the other Metal Frame (3).

Step 4

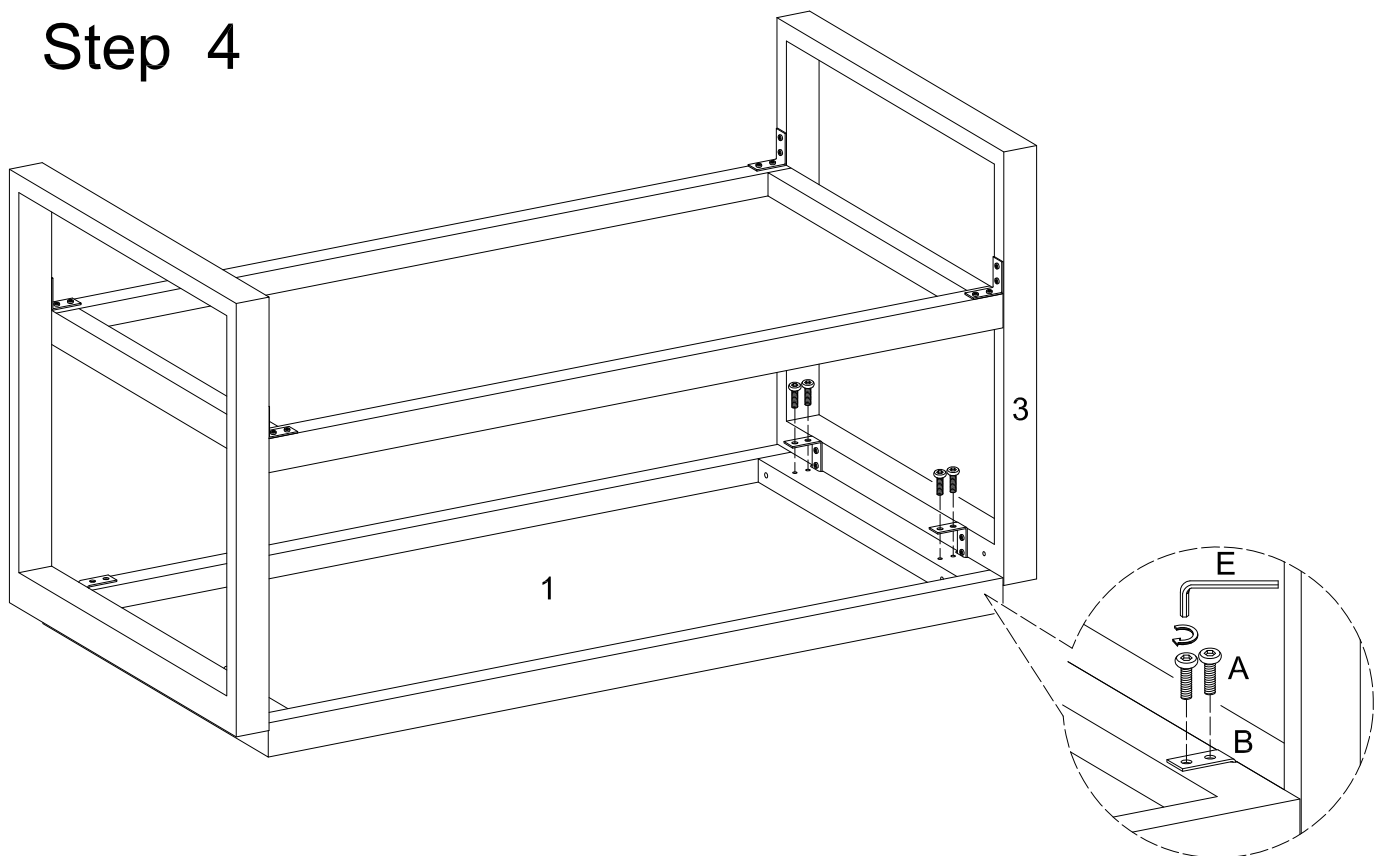

Up side down the Metal Frame (3) and the Wooden Panel (1) on a flat surface, Secure the wooden panel with the Bolts (A), the L-Shape Connector (B) and the Wrench (E).

Step 5

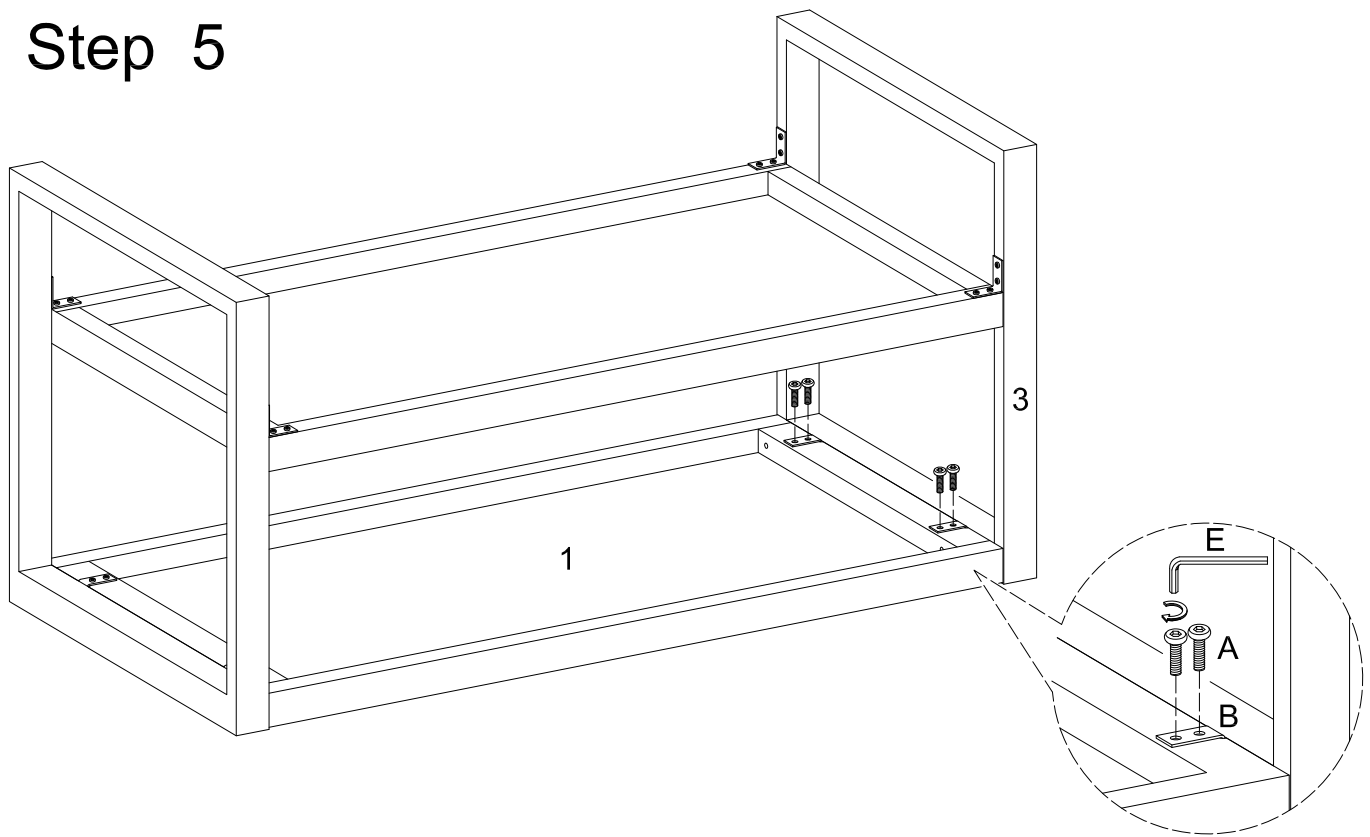

Repeat Step #4 for the other side

Step 6

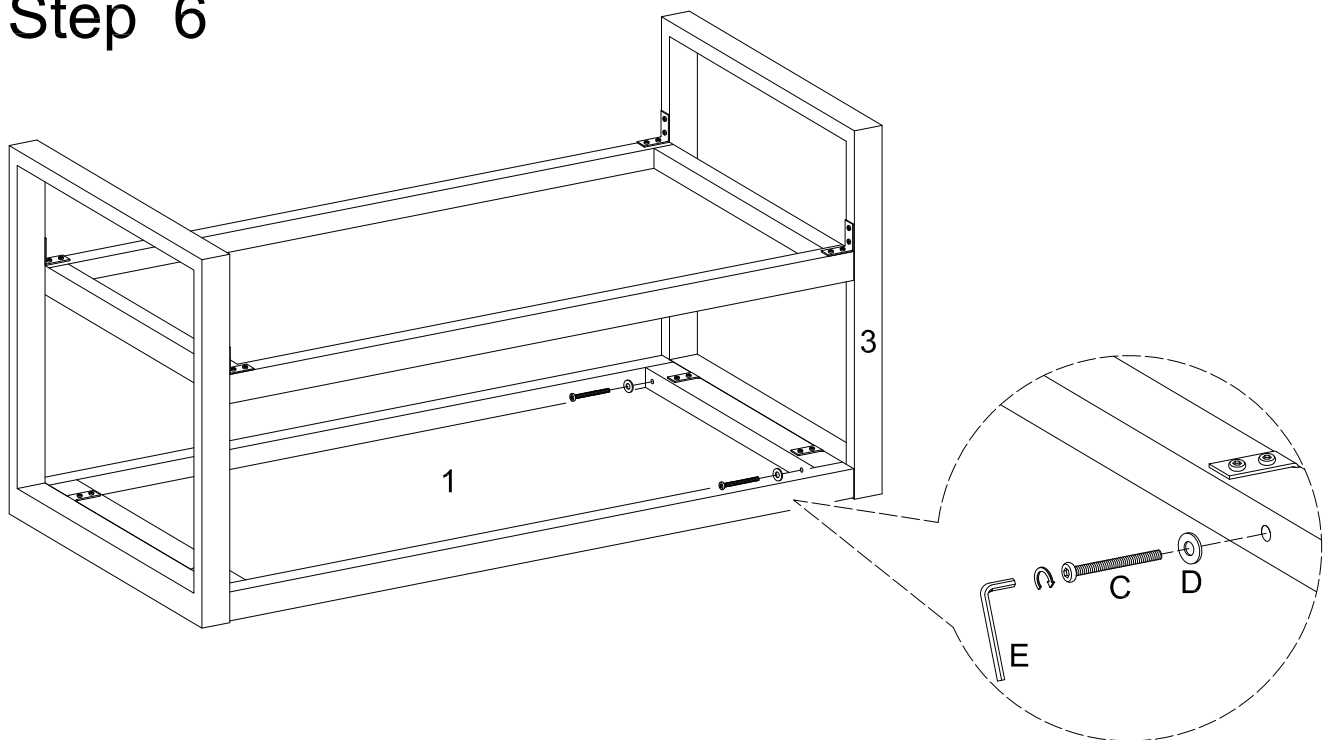

Use Washer (D), Bolts (C) and Wrench (E) to secure the Wooden Panel (1) to the Metal Frame (3).

Step 7

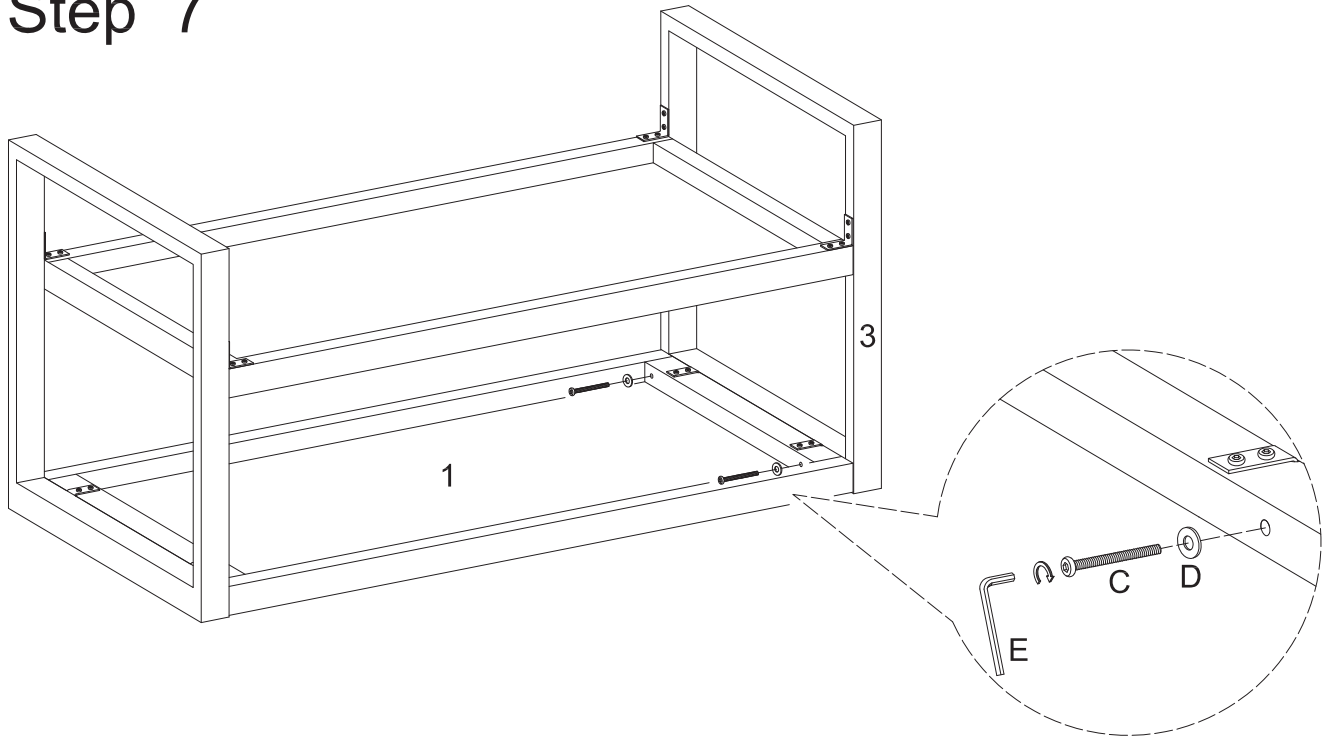

Repeat Step #6 for the other side.

Step 8

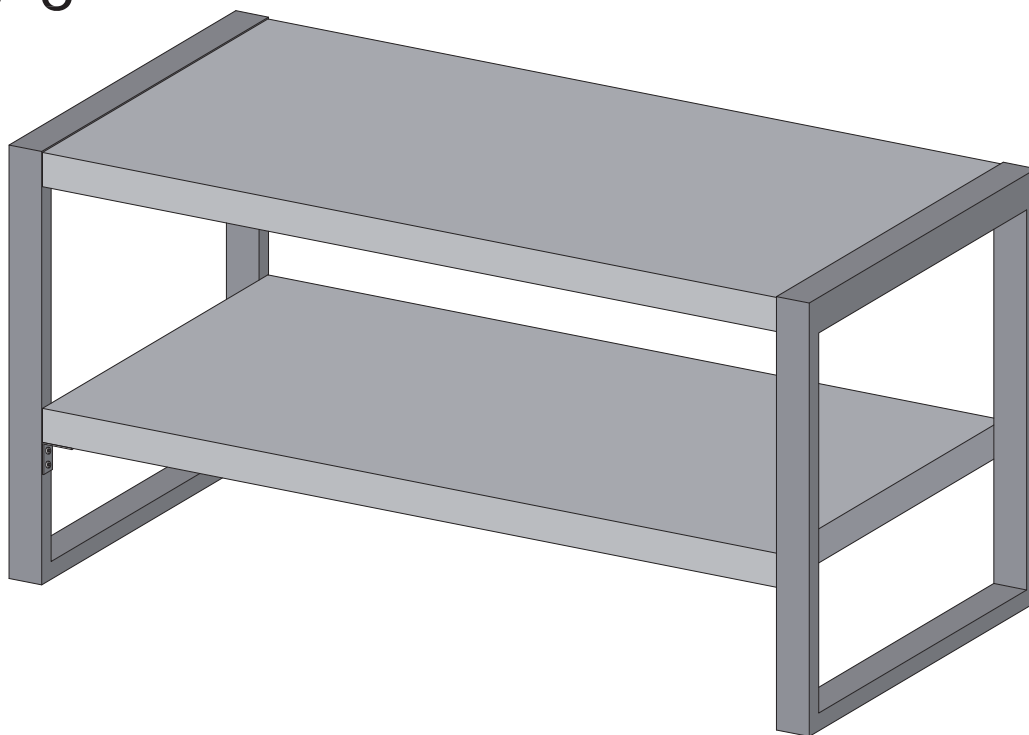

Final Assembly