

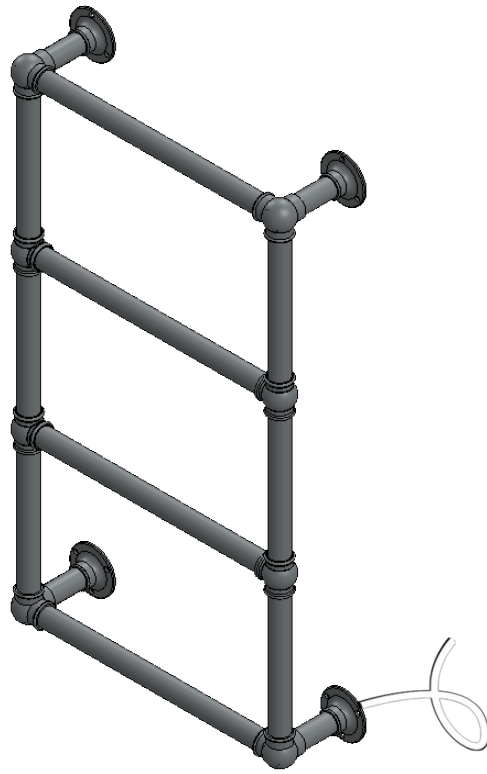

Handmade  
in the heart of  
BRITAIN



## Wollaston Electric 4 Rail

950 x 550 x 145mm

V1

02 August 2017

**WOLL-4-E-950-550-XX**

<b>UB</b> - UNLACQUERED BRASS	<b>CP</b> - POLISHED CHROME
<b>BB</b> - BRUSHED BRASS	<b>NP</b> - POLISHED NICKEL
<b>BN</b> - BRUSHED NICKEL	<b>LB</b> - LIGHT BRONZE
<b>LAB</b> - LIGHT ANTIQUE BRONZE	<b>MB</b> - MEDIUM BRONZE
<b>MAB</b> - MEDIUM ANTIQUE BRONZE	<b>DB</b> - DARK BRONZE
<b>DAB</b> - DARK ANTIQUE BRONZE	<b>GP</b> - GOLD PLATED
<b>AG</b> - ANTIQUE GOLD	<b>GM</b> - GUN METAL
<b>MWP</b> - MATT WHITE P.COAT	<b>MBP</b> - MATT BLACK P.COAT

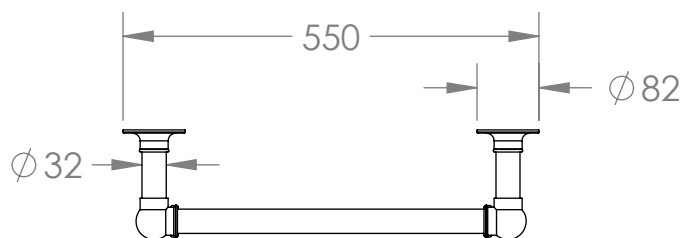
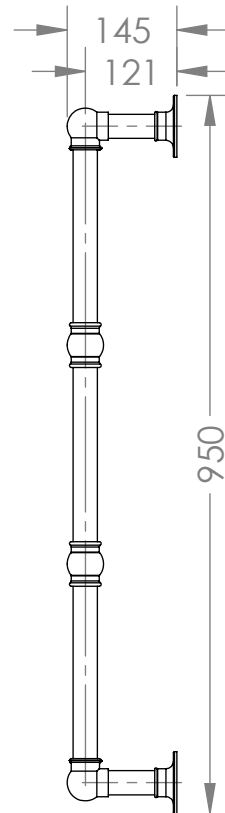
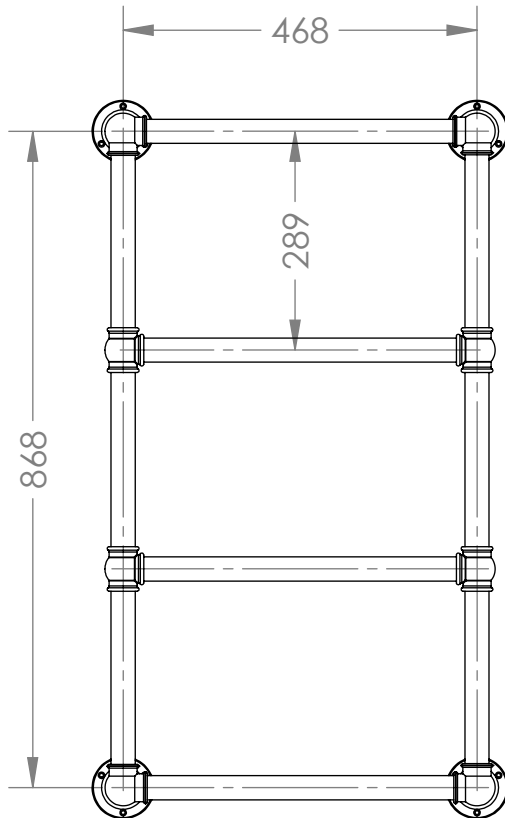

**THE STERLINGHAM<sup>CO.</sup>LTD.**

SCALE: 1:8

APPROX WEIGHT 6.08KG

MANUFACTURED FROM BRASS

Units 2 & 2A Stamford Street  
Amblecote, Stourbridge,  
Worcestershire  
England, DY8 4HR

Telephone : 01384 370901  
Fax : 01384 880159  
sales@sterlingham.co.uk  
www.sterlingham.co.uk

**For Electric Towel Warmers:**

Default cable exit is bottom right, 3m cable length - this can be modified, please state your requirements upon placing your order.