

# NIGHTSTAND SET OF 2

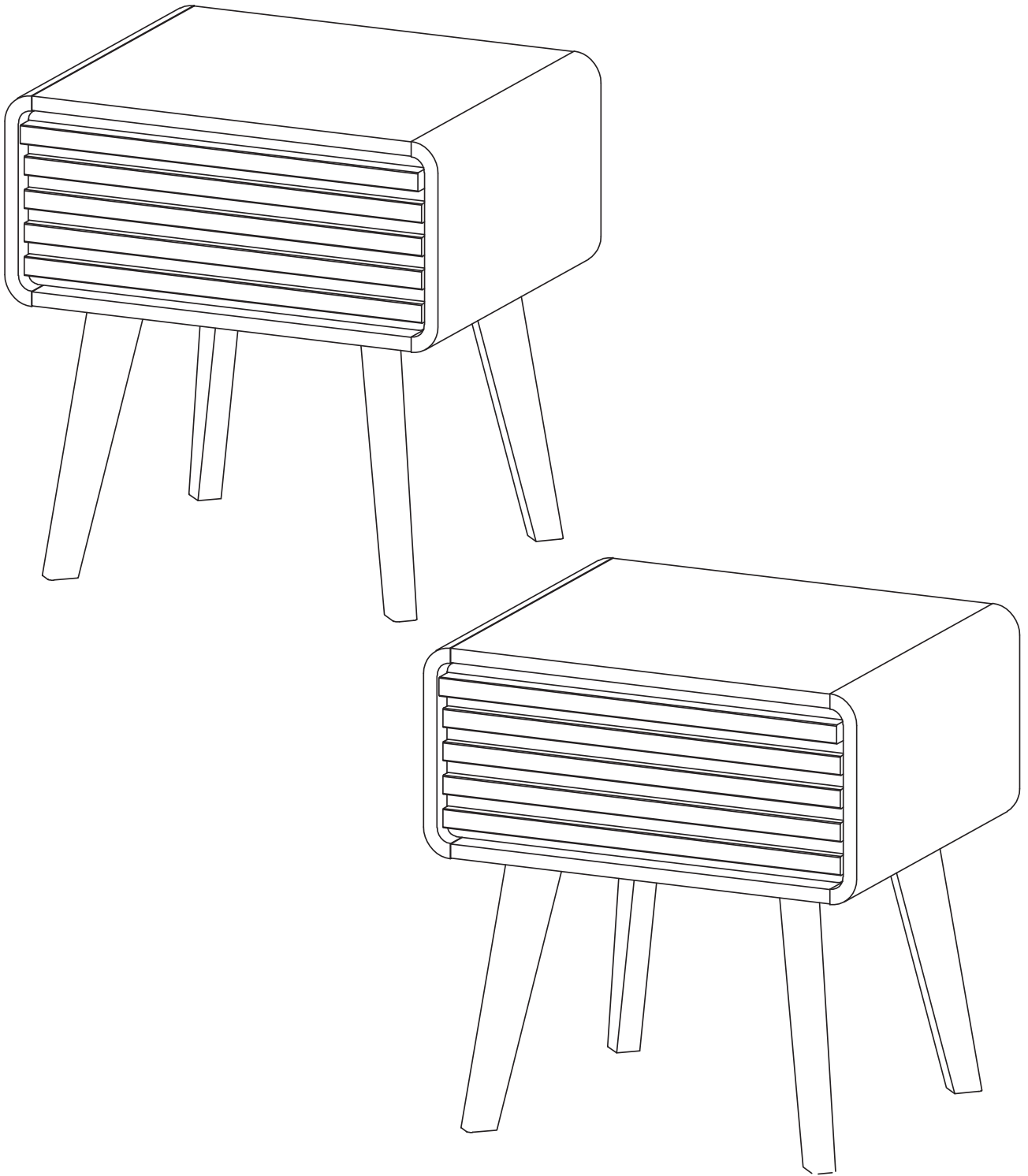

ASSEMBLY INSTRUCTIONS

# Join us!

We've got more for you. Be part and enjoy:

- Privileged Customer Care
- 10% Off Your Next Purchase (no min spend)
- 1-Year Free Warranty
- Early Access To Upcoming Launches

## Contact Us!

**For any enquiries or issues regarding your purchase, you can contact us directly.**

# Before you start...

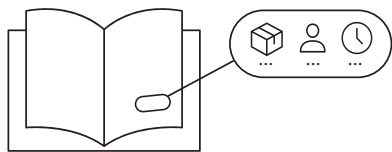

Ensure you have received all cartons and familiarize yourself with the workload. Make sure there are enough helping hands to assist you, and that you have allocated the time required to assemble your new product.

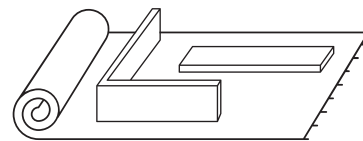

Make sure you have cleared enough space in your home for the assembly. We recommend protecting your floor with a mat or cardboard to avoid scratches during the assembly process.

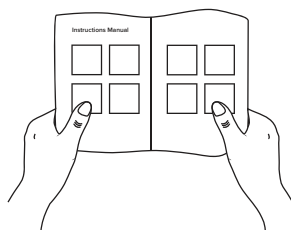

Read instructions carefully and check no parts are missing.

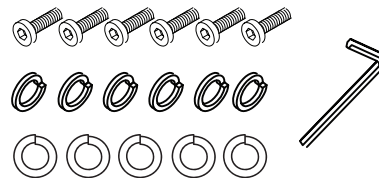

Lay out all hardware on a soft surface so you can easily identify them.

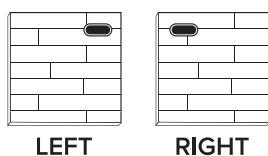

Carefully identify all components in order to differentiate which pieces are left and right.

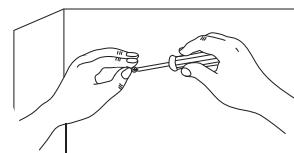

Install your new product carefully following the instructions. Don't skip ahead!

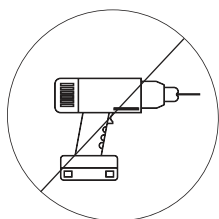

**DO NOT** over tighten screws or use a drill. It will damage the product.

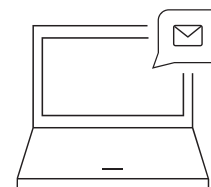







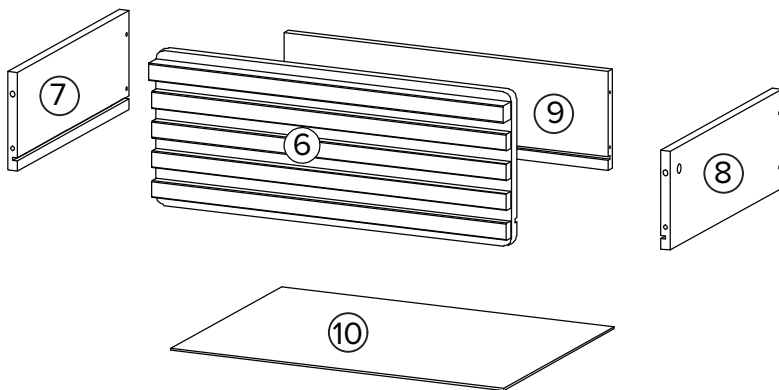
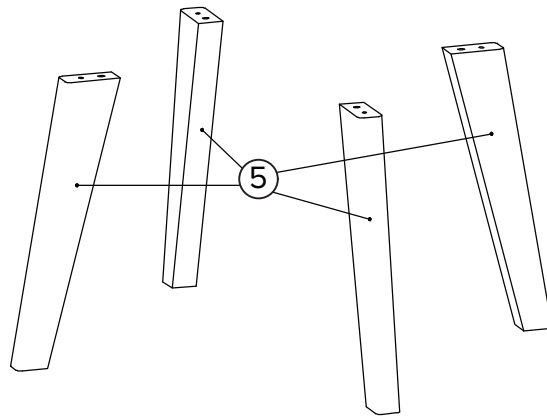
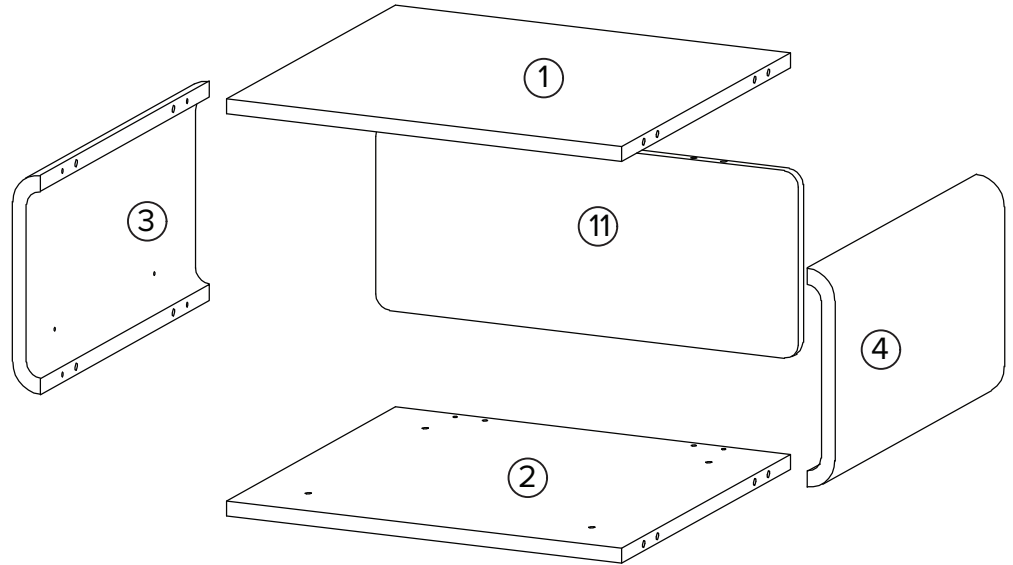

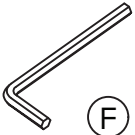

If you need further assistance with assembling your product, please contact us.



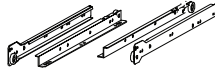

# Parts

- ① x2
- ② x2
- ③ x2
- ④ x2
- ⑤ x8
- ⑥ x2
- ⑦ x2
- ⑧ x2
- ⑨ x2
- ⑩ x2
- ⑪ x2





# Hardware x2

- |                          |   |   |                          |   |                                     |                          |   |                                     |
|--------------------------|---|---|--------------------------|---|-------------------------------------|--------------------------|---|-------------------------------------|
| <input type="checkbox"/> |    | Cambolt<br>Ø 6 x 35 mm<br><b>x14</b>    | <input type="checkbox"/> |    | Allen Key<br>L 4<br><b>x1</b>       | <input type="checkbox"/> |  | Screw<br>M 6 x 10.5 mm<br><b>x4</b> |
| <input type="checkbox"/> |    | Camlock Big<br>Ø 15 mm<br><b>x8</b>     | <input type="checkbox"/> |    | Screw<br>M 7 x 50 mm<br><b>x4</b>   | <input type="checkbox"/> |  | Floor Protector<br><b>x4</b>        |
| <input type="checkbox"/> |    | Camlock Small<br>Ø 12 mm<br><b>x6</b>   | <input type="checkbox"/> |    | Rail<br><b>x1</b>                   |                          |   |                                     |
| <input type="checkbox"/> |  | Dowel Big<br>Ø 8 x 30 mm<br><b>x12</b>  | <input type="checkbox"/> |  | Screw<br>M 3.5 x 13 mm<br><b>x6</b> |                          |   |                                     |
| <input type="checkbox"/> |  | Dowel Small<br>Ø 6 x 30 mm<br><b>x6</b> | <input type="checkbox"/> |  | Screw<br>M 8 x 39 mm<br><b>x4</b>   |                          |   |                                     |

-  There are inner box(es) that include components required to complete this assembly.
-  Please do not completely tighten all the hardware, until each assembly step is complete.
-  Before discarding the packaging, please use the checklist to ensure that you have all the parts required to assemble your product. Please kindly note you will need the original package if you want to return the product later.
-  If parts are missing or damaged, we will gladly ship your replacements parts free of charge. Please contact us.

  
**x1**

  
**x2**

  
**90 mins**

# Step 1

Ensure your floor is properly protected, then take out board No.1, No.2, No.11 and 4 pcs of leg No.5. We recommend using cardboard or foam to lift up the boards so as to avoid scratches due to assembly actions.

Screw cambolt A to board No. 1 and No.2 (don't over screw).

Please check carefully the different sizes for dowel D and dowel E. Follow the illustration for matching the correct size dowel to the correct position.

Plug in dowel D into side holes of board No.1 and No.2.

Plug in dowel E into side holes of board No. 11.

Plug in dowel D into 4 pieces of leg No.5 respectively.

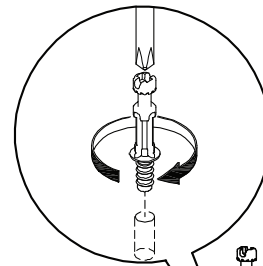
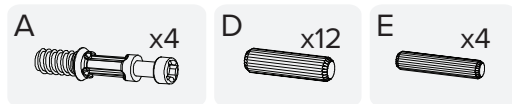
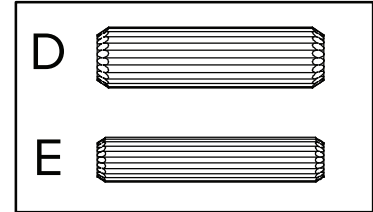

\*Don't screw too deep

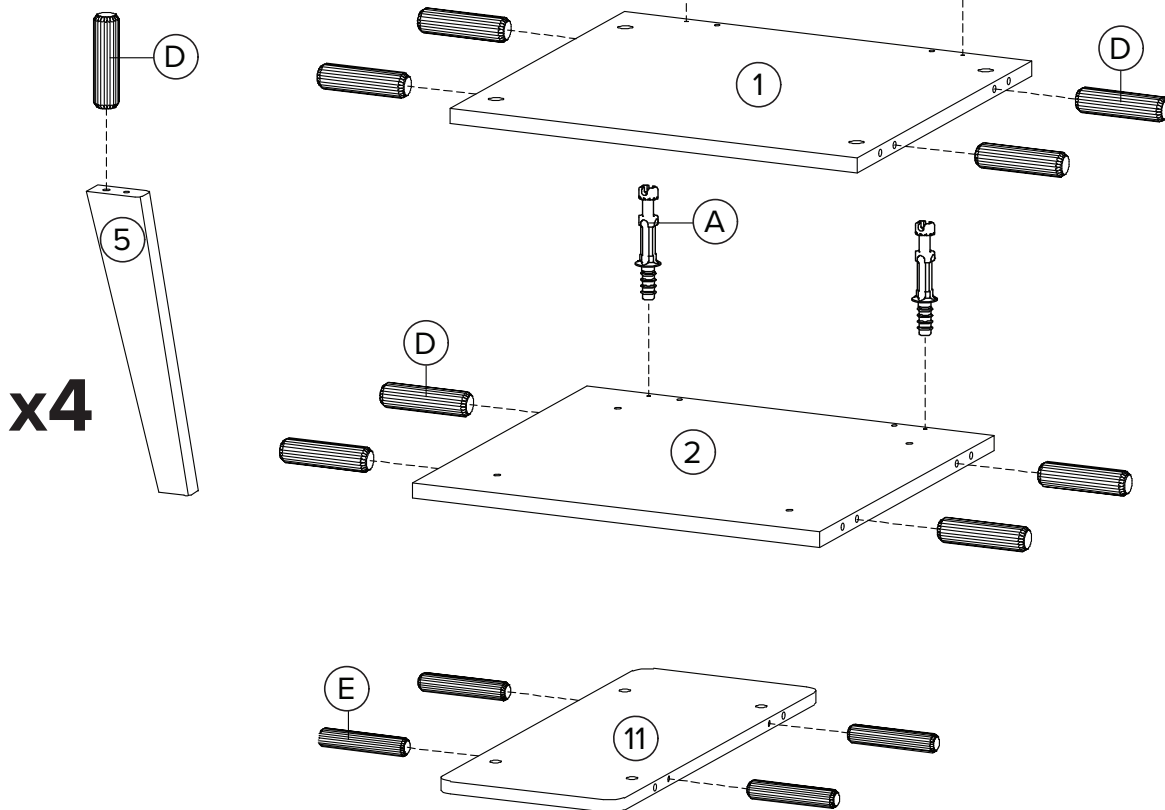
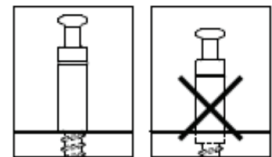

# Step 2

Take out board No.3 and No.4. Screw cambolt A into the indicated holes and tighten it.

Take out rail H and follow carefully the correct position according to the illustration. The roller of the rail must be positioned on the right position. Then use screw K to tighten it.

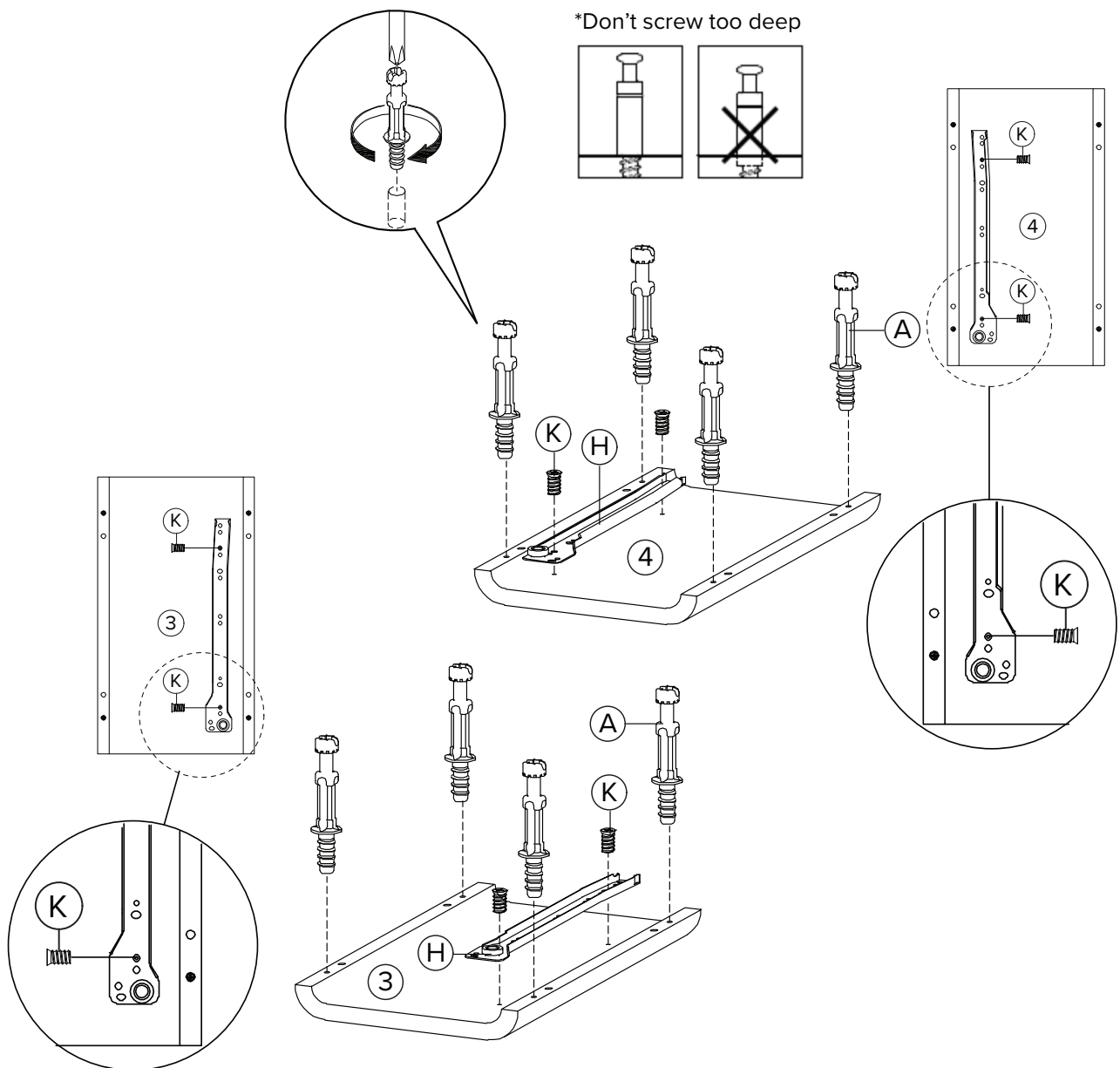

## Step 3

You may require an extra pair of hands to complete this step.

Hold and let board No.2 stand on the side. Install the 4 pcs of leg No.5 onto the board No.2 at four corners. Engage the dowel previously installed and then insert screw G and tighten to fix the legs.

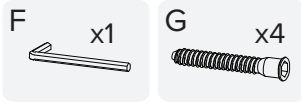
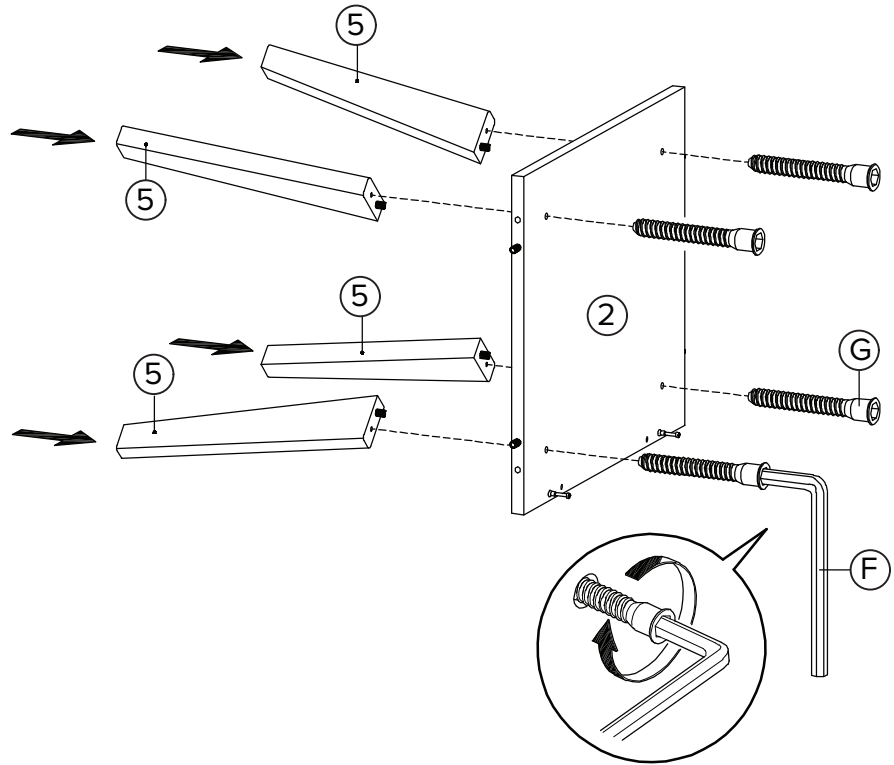

## Step 4

You may require an extra pair of hands to complete this step.

Install board No.11 in between board No.1 and No.2. Insert camlock C on board No.11, engage the previously installed cambolts from board No. 1 and 2, then slowly tighten the camlocks.

Please ensure all the boards are in place before fully tighten all camlocks.

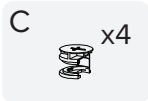
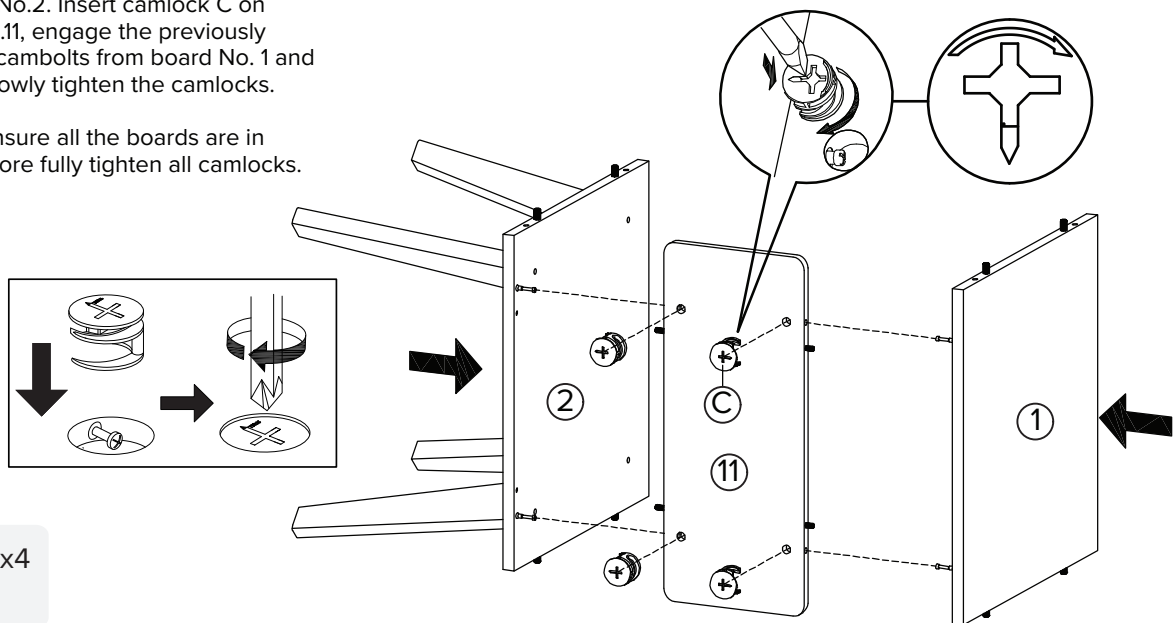

# Step 5

You may require an extra pair of hands to complete this step.

Install board No.4 to the side of table top body. Please take note carefully the correct position for placing the board No.4, according to the illustration.

Engage cambolts previously installed on board No.4 into holes on the table top body. Insert camlock B to the positions illustrated and tighten them with the Allen key provided.

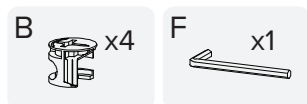
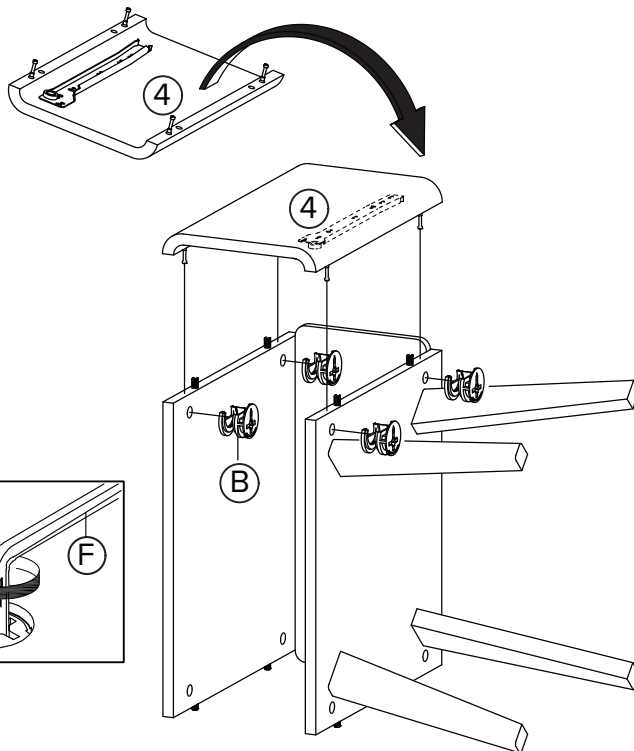

# Step 6

You may require an extra pair of hands to complete this step. Gently flip the table and let it stand with board No.4 facing the floor.

On the other side of table top body, install board No.3 with the position indicated in the illustration.

Engage cambolts previously installed on board No.3 into holes on the table top body. Insert camlock B to the positions illustrated and tighten them with the Allen key provided.

Peel the floor protector sticker L and attach to the end of the legs.

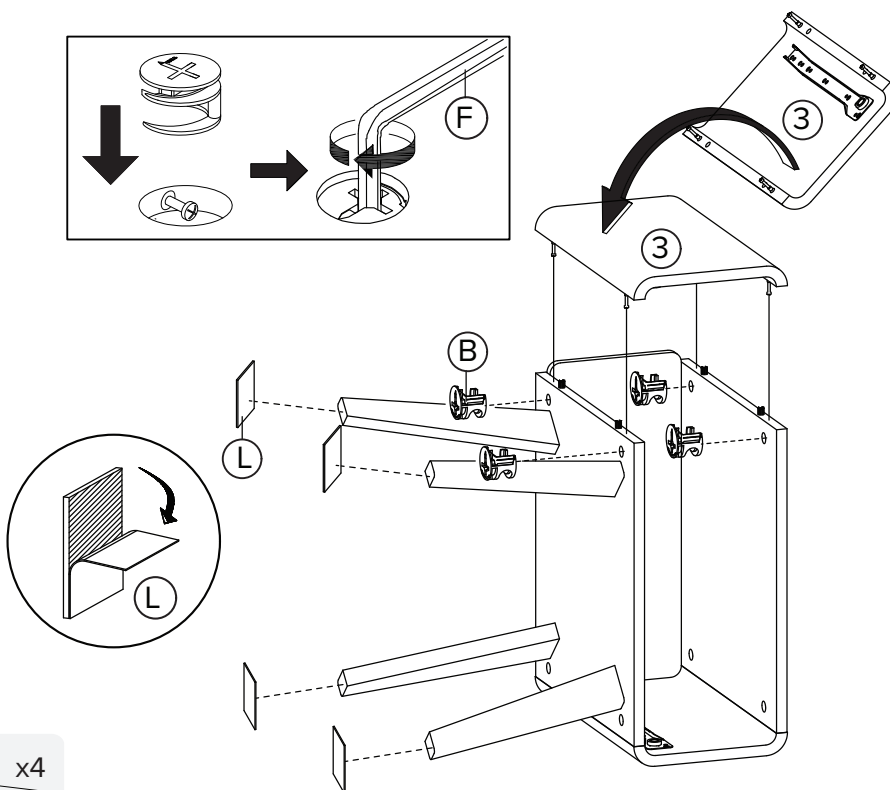

# Step 7

Prepare the drawer assembly by taking out board No.6, 7 & 8.

Screw cambolt A to drawer front panel board No.6. Plug in dowel E to the side drawer panels board No.7 & 8.

\*Don't screw too deep

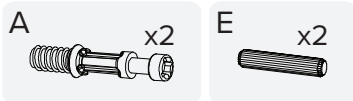
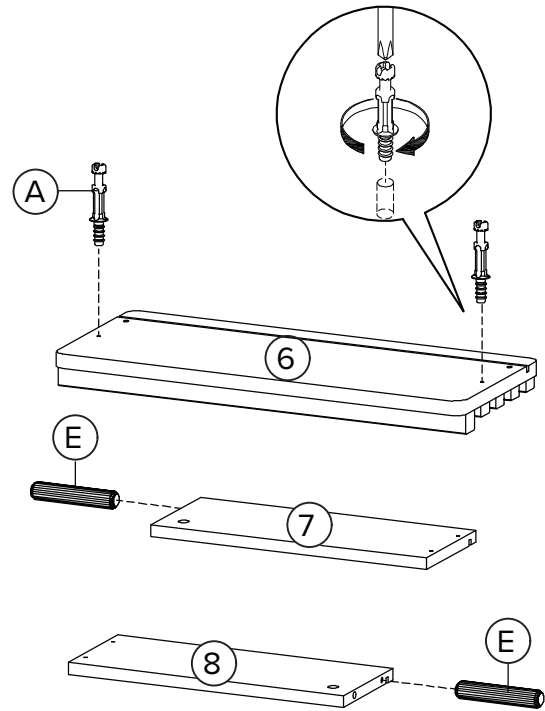
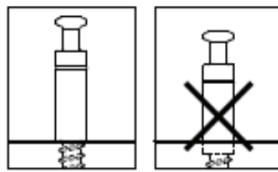

# Step 8

Install the drawer side panel No.7 and 8 to the front panel No.6 by engaging the cambolt and dowel previously installed. Use camlock C to lock and tighten the side panels. Take note of the correct camlock position carefully.

Slot in the drawer bottom panel No.10 and ensure it engages the groove completely.

Install the drawer back panel board No.9 with screw J and tighten it.

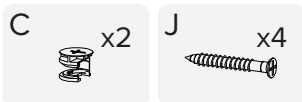
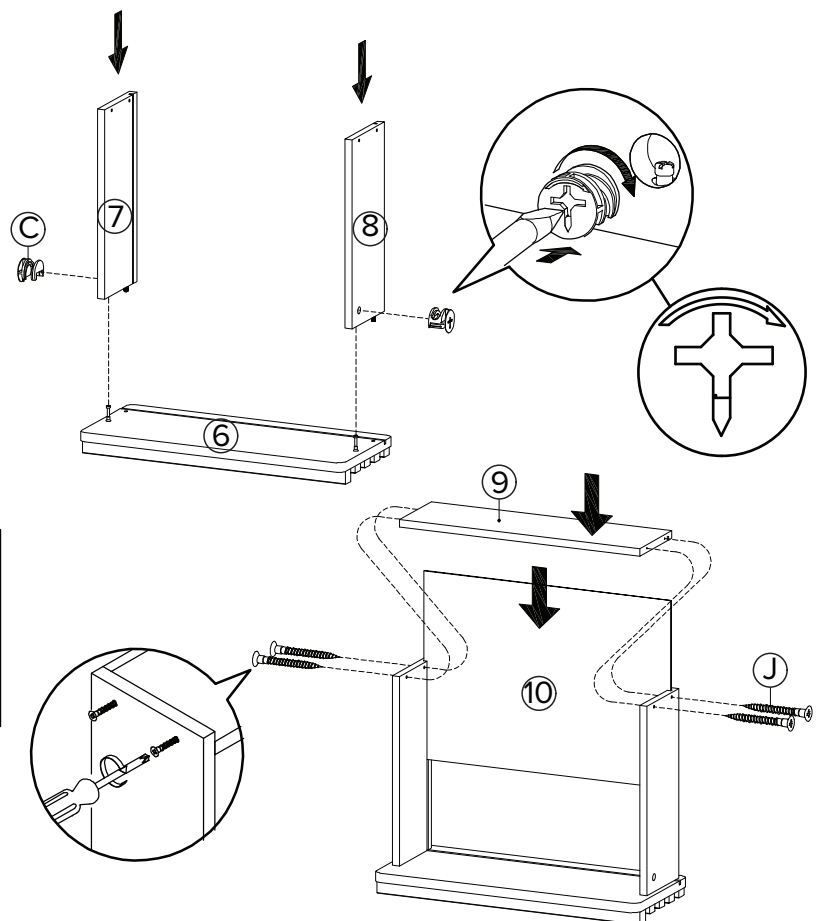
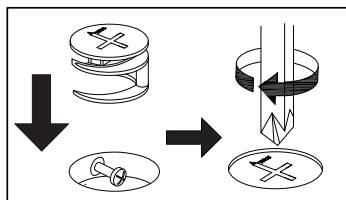

## Step 9

Face the drawer downwards. Install the rail H at both sides of the drawer. Please ensure the positioning of the rails is the same as illustrated.

Align the rails properly and use screw I to tighten the rails as illustrated.

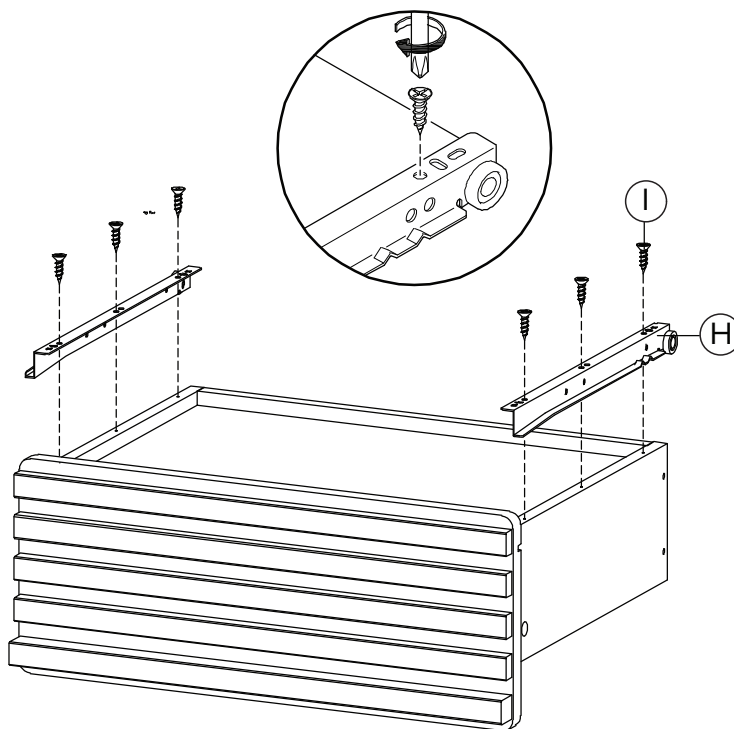

## Step 10

Slide in the drawer carefully as illustrated. Please ensure both rails are properly engaged to the groove before pushing the drawer in.

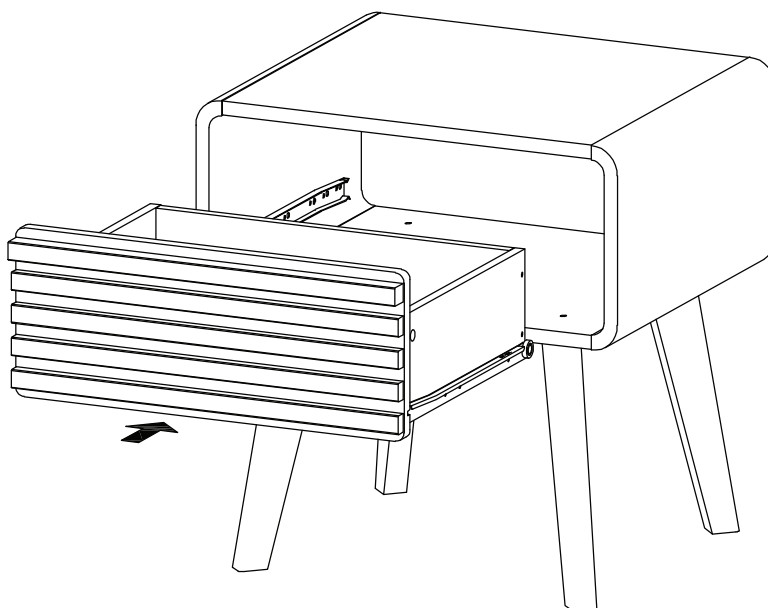
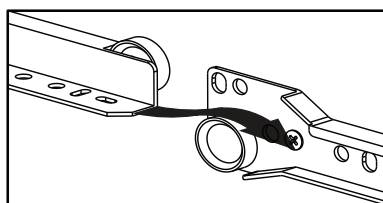

# Congratulations!

---

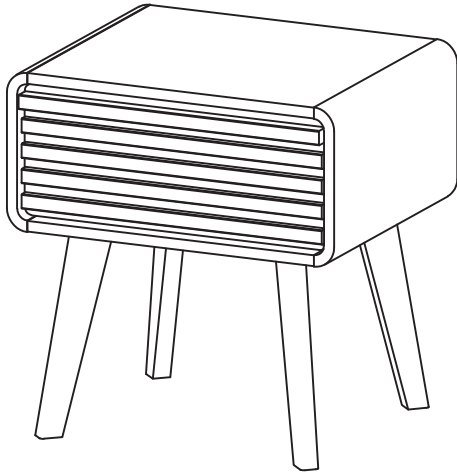

You have finished assembly 1 set of the **NIGHTSTAND SET OF 2**. Please continue to assembly remaining 1 set by repeating

---

# Finished!

---

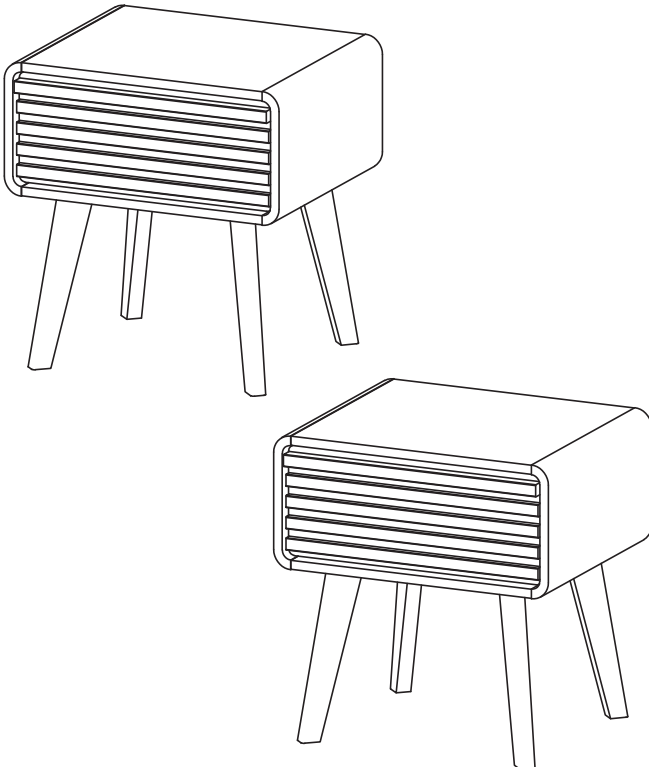

**Congratulations! We're almost there! Please perform following checks to ensure assembly is properly done.**

- Ensure there is no loose camlock or screw.
- Ensure the drawer sliding pin are properly engaged to the groove. Slide the drawer multiple times to ensure smooth sliding.
- Ensure all legs are fully tightened and not shaky.
- Ensure floor protectors L are attached to the leg ends.

**Move your product carefully, with 2 people lifting it to the preferred location. Clean the product with a dry cloth. You are all set!**

**Enjoy your fresh and updated living space thanks to the addition of your new product!**

# Care

## Instructions

Your furniture, if treated with respect and love, will last you a long time. Each piece requires light maintenance to maximize its longevity.

### **Few quick tips before using this product:**

1. Recommended weight limit for the table top is 20lbs and 10lbs for the drawer.
2. Avoid uneven weight distribution for long time as it may cause damage to the product shape.
3. Check and tighten the camlock and screw periodically as it may loose over the time.

### **How to take care of it?**

1. Avoid direct sunlight or use curtains or blinds to limit the sun exposure to the product.
2. Clean the product regularly with a dry, soft cloth.
3. Avoid using abrasive or liquid cleanser.
4. We recommend always attaching the provided floor protector to the leg ends to protect your floor.
5. Avoid placing hot objects onto the table top surface.
6. Spillage may damage the surface. Clean immediately with a dry cloth.
7. We recommend using placemats or coasters underneath glasses, cups, bowls or plates to prevent scratches to the table surface.

Follow the care instructions and look after your furniture, in return, your furniture will look after you.

We hope to see you soon!

# Frequently Asked Questions

## 1. What should I do if my product received is incomplete?

products are flat packed and come in separate boxes. Once your order has dispatched and been sent with Fedex, you will receive an email with tracking information. Please note that Fedex may deliver your boxes in separate deliveries. Kindly follow the tracking information, allowing all boxes to be received before starting assembly. If you need further assistance on deliveries tracking, feel free to reach out to us.

## 2. What should I do if my shipment is damaged or products received are defective?

We're sorry to hear that! Please email us and provide a detailed description of the damage, as well as photos (or videos, where appropriate) showing the damage. We will do our best to resolve the issue as soon as possible.

## 3. Can replacement parts be ordered?

Yes. Simply write to our customer service team, let us know your order ID and we will be happy to assist further.

## 4. Who do I contact for repair queries?

You may write to us specifying your queries and we will be able to assist you further.

## 5. What warranty do you offer for your products?

You'll just need to submit your warranty registration upon receiving product at **warranty/register**. You can print a copy of your order from Order Details in Amazon and upload it as your proof of purchase. More details can be found in **Warranty section**.

## 6. How do I claim my warranty?

Easy! Just email us and provide a detailed description of the fault as well as photos.

## 7. What should I do if I want to return the product?

We offer 30-day return policy upon product received. To initiate a return request, please message us through Amazon or contact our customer service team with your reason of returning so we can facilitate the request and assist you further. For more details on the return policy, please refer to **Return section**.

# Warranty & Return

## **1 YEAR LIMITED WARRANTY STATEMENT FOR MANUFACTURING DEFECTS**

Please read this limited warranty carefully. To maintain your warranty, you will need to comply with the conditions stated here. This warranty is for manufacturing defects only and does not cover damages as a result of misuse.

1. Please be sure to register your product at **warranty/register** to receive up to date warranty and product information.
2. Your new product comes with 1-year warranty against manufacturing defects. The warranty starts on the date of purchase. No warranty will be honoured without an original sales receipt. The warranty and financial responsibility of the manufacturer only applies to the products itself.
3. Manufacturing defects include circumstances where the product has broken under normal use and no longer provides proper support. In the event you encounter a manufacturing defect, please stop using this product immediately and contact customer service.
4. This warranty applies only when the product has been properly used by consumers who purchased the product from authorized channels as a new product. Proper use means using the product on a level surface where all legs touch the floor with an equal distribution of weight. Proper use also means that the product was not abused by the consumer, as defined by the manufacturer. This warranty does not constitute agreement to replace other parts.
5. If the product fails due to manufacturing defects, the manufacturer will repair or replace at its discretion and reserves the right to substitute comparable materials or models and does not guarantee that the replacement part will match existing pieces.
6. In the event the product needs to be inspected by the manufacturer to determine a warranty claim, the transportation cost or removal cost is borne by the consumer.

## **30-DAY RETURN POLICY**

We believe you will be thrilled with your purchase. That's because we go out of our way to ensure that products are designed and built to be just what you need. We understand, however, that sometimes a product may not be what you expected it to be. In that event, we invite you to review the following terms related to returning a product.

## The Return

Returns are to be made within 30 days of the date you received the product. To initiate return request, please message us or contact our customer service team with your reason of returning so we can facilitate the request and issue return authorization to you. Please note the policy is subject to the conditions below:

1. Only undamaged items in original packaging will be accepted under the Returns Policy. Any items that are not returned to us in the original packaging and/or in original condition will incur an additional handling fee (deducted from your refund). It is your responsibility to package the item sufficiently to avoid damage in transit back to us. We encourage customers to photograph the items scheduled for return and the condition of the packaging before handing over to the delivery company.
2. We will not refund a product that you have bought and received where, in our reasonable opinion, the product has: become of unacceptable quality due to fair wear and tear; misuse; using it in an abnormal way; or failure to take reasonable care.
3. We will not be able to offer standard return policy after 30-day timeframe has passed. However, our customer service team is always an email away if you require further assistance with your products.

## The Refund

We will assist you to complete the return process. We will perform standard inspection upon your return is received and will send you a message to acknowledge the return if item is presenting in original condition with original packaging.

You will be refunded the full amount less return shipping cost. Please note that while shipping charges on original deliveries are subsidized, on returns the full shipping amount paid by to the delivery partner will be deducted from your refund. **All refunds will take 2 business days to process upon return acknowledgement from us, however actual fund reversal date will depend on your card company's own processing schedule.**

Kindly note, in the event of returning a defective or damaged item, **we will however absorb the shipping charges and ensure your return/exchange experience is hassle free.**

## The Exchange

We put quality as one of our top priorities – we work with experienced manufacturers and have every piece of product going through strict quality control process. We want to make sure your product reaches you safe and sound, however we are happy to do an exchange in case you receive a defective or damaged product due to any unforeseen hiccups throughout the journey. Please message us or email us with proof of defect or damage, our customer service will evaluate the exchange request, and assist you throughout the process accordingly.