



comfort gear™
HEATERS FOR WORK, HOME AND PLAY!

USER'S MANUAL AND OPERATING INSTRUCTIONS

World Marketing of America, Inc. (WMAI)
PO Box 192
Mill Creek, PA 17060

Model #
PPH10
PPH18



ANSI Z21.103-2017 Unvented portable type
gas camp heaters for indoor and outdoor use

READ INSTRUCTIONS CAREFULLY:

Read and follow all instructions. Place instructions in a safe place for future reference. Do not allow anyone who has not read these instructions to assemble, light, adjust or operate the heater.

PORTABLE PROPANE HEATER FOR
OUTDOOR,
EMERGENCY INDOOR, AND
RECREATIONAL ENCLOSURES
FOR US SALE EXCEPT
MASSACHUSETTS

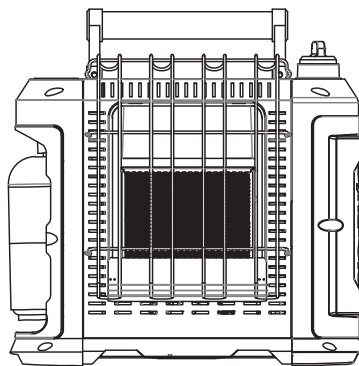

10K Portable
Heater

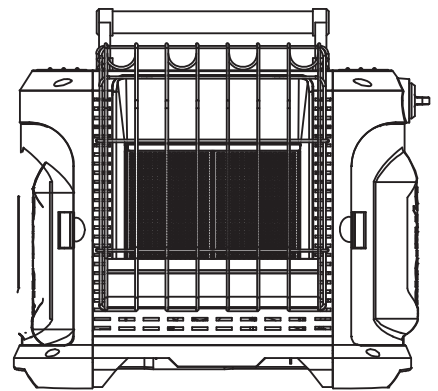

18K Portable
Heater

⚠ WARNING

FIRE OR EXPLOSION HAZARD

If you smell gas:

1. Do not attempt to light appliance.
2. Extinguish any open flame.
3. Disconnect fuel supply.
4. Leave the area immediately.
5. Allow gas to dissipate 5 minutes before relighting the appliance.

Do not store or use gasoline or other flammable vapors and liquids in the vicinity of this or any other appliance.

Failure to follow these instructions could result in fire or explosion, which could cause property damage, personal injury, or death.

⚠ WARNING

CARBON MONOXIDE POISONING MAY CAUSE DEATH OR INJURY

When used without adequate combustion and ventilation air, heater may give off excessive CARBON MONOXIDE, an odorless, poisonous gas.

This is an unvented gas-fired heater. The heater uses air (oxygen) from the area in which the heater is used.

Adequate combustion and ventilation air must be provided. (Refer to page 4)

This heater is equipped with a SAFETY SYSTEM designed to turn off the heater if not enough fresh air is available.

DO NOT TAMPER WITH THE SAFETY SYSTEM!

If the heater shuts off, do not relight until you provide fresh air. If heater keeps shutting off, have the heater serviced. Keep burner and control compartment clean.

CONSUMER: Retain this manual for future reference.

Questions, problems, missing parts? Before returning to your retailer, call our customer service department at 800-776-9425 8:30 a.m. – 5:00 pm CST, Monday – Friday or email us at info@worldmktng.com
www.worldmktng.com

TABLE OF CONTENTS

Service / Parts Ordering Information 1
General Information 3
General Safety Instructions 4
Tank Installation Instructions 5
Tank Installation for 20 lb. Propane Cylinder 6
Additional Information Regarding Optional Accessories to Connect a 20lb LP Tank 6
Lighting Operation Instructions 7
Maintenance 9
Troubleshooting 10
Parts List 12
Warranty 14

 WARNING:

Every time hose or tank is connected to unit, connection must be checked for leaks in one or more ways: Apply soapy water to connection, look for bubbles, listen for hiss of escaping gas, feel for extreme cold, smell for rotten egg odor. Do not use if leaking!

 WARNING:

Any changes to this heater or its controls can be dangerous.

 WARNING:

Early signs of carbon monoxide poisoning resemble the flu, with headache, dizziness and/or nausea. If you have these signs, heater may not be working properly.
Get fresh air at once! Have heater serviced.

 WARNING:

Some people-pregnant women, persons with heart or lung disease, anemia, those under the influence of alcohol, those at high altitudes - are more affected by carbon monoxide than others.

 WARNING:

If the recreational or commercial enclosure does not have a window or roof vent that is open, DO NOT USE THIS HEATER inside.

NOTICE: Not for use in a "dwelling home" in California. Never use these heaters in a bedroom or bathroom.

 WARNING:

This product and the fuels used to operate this product (liquid propane), and the products of combustion of such fuels, can expose you to chemicals including benzene, which is known to the State of California to cause cancer and reproductive harm.
For more information go to www.p65Warnings.ca.gov

EMERGENCY INDOOR USE IS DEFINED AS

1. The permanent heating system is temporarily out of service.
2. Heat is necessary to prevent damage to the property or contents.
3. The temporary heating equipment is not left unattended.

NEVER LEAVE THE HEATER UNATTENDED WHILE BURNING!

GENERAL INFORMATION:

- This heater is safe for indoor use in small recreational enclosures, having means for providing combustion air and ventilation, such as enclosed porches, cabins, fishing huts, trailers, tent trailers, tents, truck caps and vans. It may be used for emergency indoor heating when connected to a disposable 1 lb. propane cylinder and for indoor use in commercial enclosures, having means for providing combustion air and ventilation, such as construction trailers or temporary work enclosures.
 - When the heater is cold or at room temperature, it will take a few minutes for the burner to turn bright orange. This is normal, and the heater is working properly. Also, during the initial lighting, the oil used during manufacturing process needs to burn off. This can take up to 60 minutes of continuous burning. Some odor and yellow flames may occur during this time but will diminish after the burn-in period.
 - It is recommended not to use the heater in windy conditions. The heater may flutter reducing the effectiveness of the appliance and could have excessive pilot outages.
 - When moving heater when lit or bumping heater setting it down, tip over switch may shut off heater. If this happens, re-light.
 - Operating time will vary depending on the heater setting and the supply cylinder size. See chart and "Cold Weather Operations" section.
- NOTE: THIS HEATER MAY BE OPERATED WITH DISPOSABLE 1LB. PROPANE CYLINDERS OR WITH (1) REMOTE REFILLABLE PROPANE CYLINDER MAX. 20 LBS USING WMAI KIT # 20-7512F, WHICH INCLUDES A 12' PROPANE HOSE AND FUEL FILTER (SOLD SEPARATELY)**

COLD WEATHER OPERATION:

- Cold weather is generally defined as ambient temperatures below 32 degrees F.
- 1 lb. propane cylinders have difficulty producing sufficient gas at lower temperatures and can "freeze-up", reducing the time of operation by as much as 50-70%. For this reason, it is recommended to use only 20 lb. propane tanks under these conditions.
- If a 1 lb. tank is used in cold weather, such as in an ice fishing hut, following are some operating suggestions;
 1. Expect operating times to be significantly reduced.
 2. Never use only a single 1lb. tank on the 18K models.
 3. Never set the heater directly on the ice. Set the heater on a rigid piece of flame retardant insulation and make sure the ventilation slots on the bottom of the heater are not obstructed.
 4. Elevate the heater slightly above the ground level. Insure the unit is level and secure and cannot be knocked over.
 5. Adequate ventilation and combustion air must be provided.
 6. Maintain all clearances as specified on Page 4.



Carefully watch the Heater for signs of the 1 lb. cylinder "freezing-up". If the lower portion of the burner starts to turn from orange to blue and begins sputtering immediately, shut off the heater and remove it from any enclosure.

**NEVER LEAVE THE HEATER
UNATTENDED WHILE BURNING!**

MODEL NO.....	PPH10 / PPH18
GAS TYPE	PROPANE
INPUT BTU/HR.	PPH10 Series - 5,500 - 10,000
.....	PPH18 Series - 5,500 - 9,000 - 18,000
MAX. SUPPLY PRESSURE.....	BOTTLE PRESSURE
CLEARANCE TO COMBUSTIBLES	
TOP	30 inches (762 mm)
FRONT	24 inches (310 mm)
SIDES	6 inches (153 mm)
REAR	0 inches (0 mm)

CAUTION:

- Some linoleum surfaces may discolor if heater is placed directly on these floor coverings.

Cylinder Size	Operating Time	
	PPH10 (10K)	PPH18 (18K)
One 1 lb. cylinder	2.2 hrs (high) - 4.2 hrs (low)	NOT RECOMMENDED
Two 1 lb. cylinders	N/A	2.4 hrs (high) - 4.7 hrs (medium) - 9.2 hrs (low)
One 20 lb. cylinder	45 hrs (high) - 79 hrs (low)	25 hrs (high) - 48 hrs (medium) - 79 hrs (low)

GENERAL SAFETY INSTRUCTIONS

THIS IS A HEATING APPLIANCE. DO NOT OPERATE THIS APPLIANCE WITHOUT THE WIRE GUARD INSTALLED. DO NOT ATTEMPT TO WARM OR COOK FOOD ON THIS HEATER.

- Do not use non-approved attachments on this heater.
- **Due to high temperatures, the appliance should be located out of traffic and away from combustible materials.**
- **Children and adults should be alerted to the hazard of high surface temperatures and should stay away to avoid burns or clothing ignition.**
- **Young children should be carefully supervised when they are near the appliance.**
- **Do not place clothing or other flammable material on or near the appliance.**
- Do not operate heater in any moving vehicle.
- This heater can be used in a recreational or commercial enclosure with a window or roof vent. It may also be used outdoors.
- This heater requires a vent area of 18 square inches (example 4 1/4" x 4 1/4" opening) minimum for adequate ventilation during operation. Do not use other fuel burning appliances inside.
- Gas pressure at heater is regulated and fixed at 11" w.C. When using a remote hose connection to heater regulator(s), do not regulate or reduce propane tank supply pressure to heater.
- Regulator(s) in heater must always be in place during operation.
- **Any guard removed for servicing the appliance must be replaced prior to operating the heater.**
- **The appliance should be inspected before each use. Frequent cleaning may be required. The control compartments, burner(s) and circulating air passageways of the appliance must be kept clean, see MAINTENANCE.**
- DO NOT use this heater if any part has been under water. Immediately call a qualified service technician to inspect the heater and to replace any part of the control system and any gas control which has been under water.
- When used without adequate combustion and ventilation air, this heater may give off excessive CARBON MONOXIDE, an odorless, poisonous gas.
- Some people - pregnant women, persons with heart or lung disease, anemia, those under the influence of alcohol, those at high altitudes - are more affected by carbon monoxide than others.
- Cylinders must be disconnected when the heater is not in use.
- When heater is placed on the ground, make sure the ground is level and keep any objects at least 15" from the edge of the heater. This heater is equipped with a tip over switch that will shut the heater off if the heater tips over. However, do not leave heater unattended or where children may cause the heater to tip over. Never operate the heater while sleeping!
- Keep remote 20 lb. refillable cylinders at least 6 ft. away from heater at all times.
- Do not leave this appliance unattended while it is in operation. Keep children and pets away from the appliance at all times.
- This heater can be used in a recreational enclosure only if the enclosure has a window or roof vent.

NEVER LEAVE THE HEATER UNATTENDED WHILE BURNING!

HANDLE POSITIONING FOR NORMAL OPERATION

The heater ships with the handle in a compact position that must be raised for normal operation (Fig. 1a)

- Grab handle and pull directly upward until the handle snaps into position.
- Do not lower the handle to the previous location. The “UP” position is the normal operating orientation.

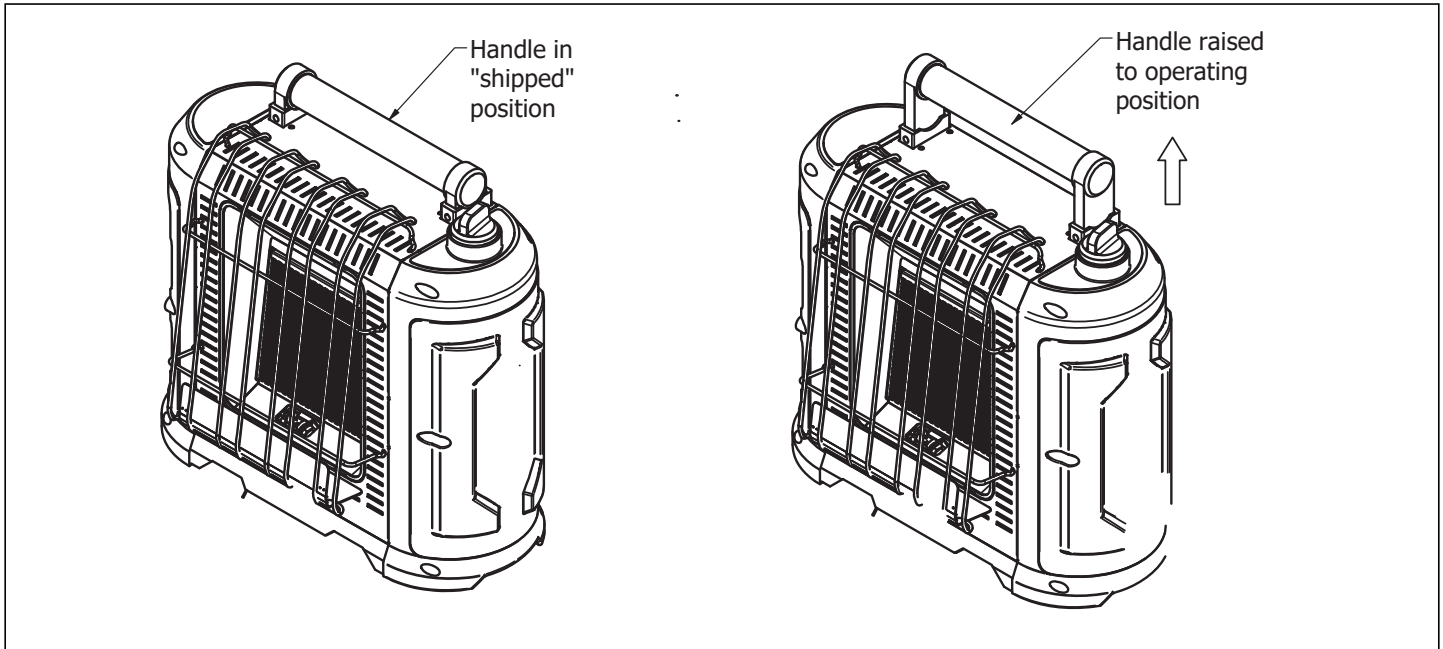

Fig. 1a - Handle Position

TANK INSTALLATION INSTRUCTIONS

Tank Installation for DOT Certified 1 lb. Propane Cylinder(s) (Fig. 1)

- Open easy access tank compartment door(s). (On 18K Model Only)
- Locate regulator and swivel it upward by hand to provide better access for cylinder
- Attach cylinder(s) to swivel mount by gently turning clockwise until it is hand tight. Do not overtighten. Do not use tools to tighten.
- Check for gas leaks by using a 50% soap-water solution at the joint of the regulator and cylinder.

Tank Installation for 20 lb. Propane Cylinder (Fig. 1b)

- Open easy access tank compartment door. (On 18K Model Only)
- Locate regulator and swivel it upward by hand to provide better access.
- Attach Fuel Filter, Model 20-7512F to swivel mount by gently turning clockwise until it is hand tight. Do not over tighten. Do not use tools to tighten.
- Attach WMAI hose end adapter (No. 20-7512F) , to fuel filter by gently turning clockwise until it is hand tight. Attach other end of hose to the LP cylinder. Do not overtighten. Do not use tools to tighten.
- Make sure heater control knob is in the "off" position. Open the LP cylinder valve and check for leaks by using a 50% soap-water solution at all threaded connections.
- Close the Door and make sure the hose is routed through the cutout on the underside of the door.
- Close the access door as needed.

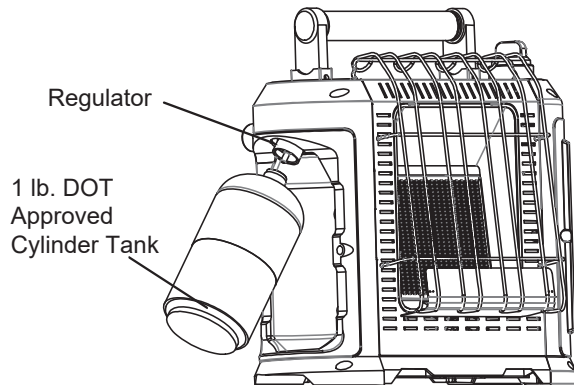

Fig. 1 - 1 lb. Cylinder Tank Installation

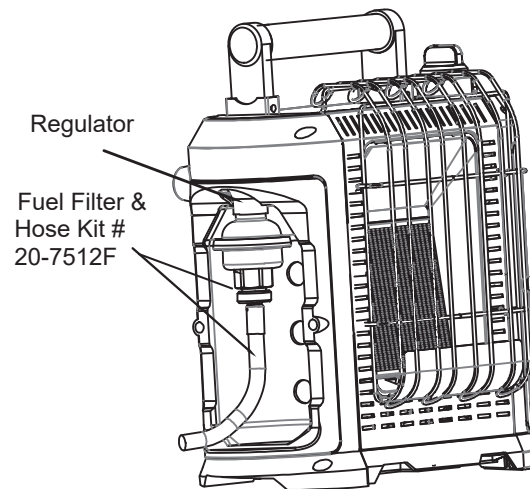

Fig. 1b - Remote Tank Installation

ADDITIONAL INFORMATION REGARDING OPTIONAL ACCESSORIES TO CONNECT A 20 LB LP TANK

- Please note: this heater may be operated with (1) remote refillable propane cylinder max. 20 Lbs.
- Any CSA certified hose with a CGA 600 fitting and excess flow device, that is appropriate for this application may be used to connect a 20 lb. propane tank.
- Non-certified or handmade hoses and adapters may not be used to connect a 20 lb. propane tank.
- The use of a fuel filter is also recommended but not mandatory. The fuel filter can reduce potential contaminants from the 20 lb. LP tank/hose and extend the life of the heater.
- We recommend using the WMAI 20 lb. tank connection kit model# 20-7512F, which includes (1) 12' extension hose and (1) fuel filter (sold separately).

EMERGENCY INDOOR USE

- Adequate combustion air and ventilation must be provided when the appliance is in use. Refer to General Safety Instructions on Page 4 for additional information.
- Only disposable 1 lb. cylinders, marked as PROPANE can be used with this heater.
- NEVER bring a refillable propane cylinder indoors. A fire or explosion can occur, causing property damage, serious injury, or death.
- The LP-gas cylinder(s) must be constructed and marked in accordance with the specifications for LP-gas cylinders of the U.S. Department of Transportation (DOT).
- Not for use in a Bedroom or Bathroom.

**NEVER LEAVE THE HEATER
UNATTENDED WHILE BURNING!**

LIGHTING, OPERATION, AND SHUTDOWN INSTRUCTIONS

Unvented Portable Type Heaters Must Not be Exposed to Flammable Vapors or Liquids.

1. Make sure the control knob is in the OFF position.
2. Open the access door as needed and install the one pound cylinder(s) as described on page 5.
Check for gas leaks by using a 50% soap-water solution at the joint of the regulator and cylinder.
3. Depress and turn the control knob to the pilot position.
a. If fueled by a 1 lb. propane cylinder, hold for 30 seconds.
b. If fueled by a 20 lb. propane cylinder, hold for 4-5 minutes.
With the knob still depressed, rotate the knob between the OFF and PILOT position activating the piezo igniter until the pilot flame ignites.
4. Continue holding the knob down in the PILOT position for **30 seconds or until pilot flame holds.**
5. Release the knob. The knob should return to the fully extended position and the pilot should remain lit.
6. Turn on the burner by depressing the knob slightly and gently turning the knob to the HI position.
7. Adjust heat output by turning the knob between HI and LOW position.
8. To shut down the heater, turn the knob clockwise to the OFF position and remove the gas cylinder or close the propane tank shut off valve and allow the heater to burn off the gas in the hose, then turn the heater knob to the OFF position.

⚠ CAUTION

Do not try to adjust heating levels by using the propane tank shutoff valve. After turning heater off, the guard will remain hot. Allow the heater to cool down before storing the heater.
Do not operate, store, connect or remove cylinder/hose connection near flammable items or ignition sources.

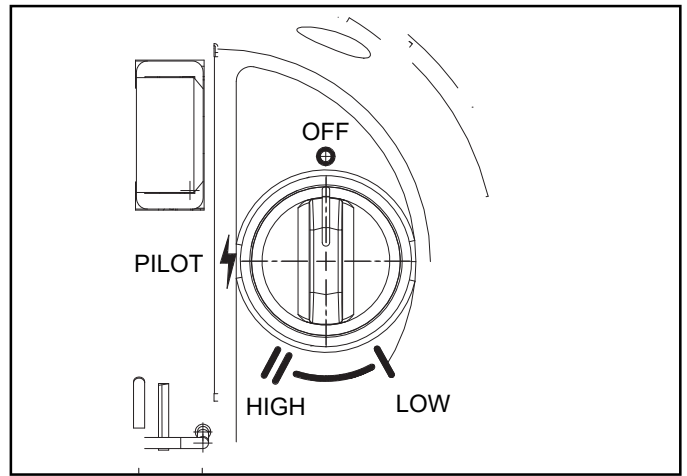

Fig. 2a - Model 10K Lighting Control Panel

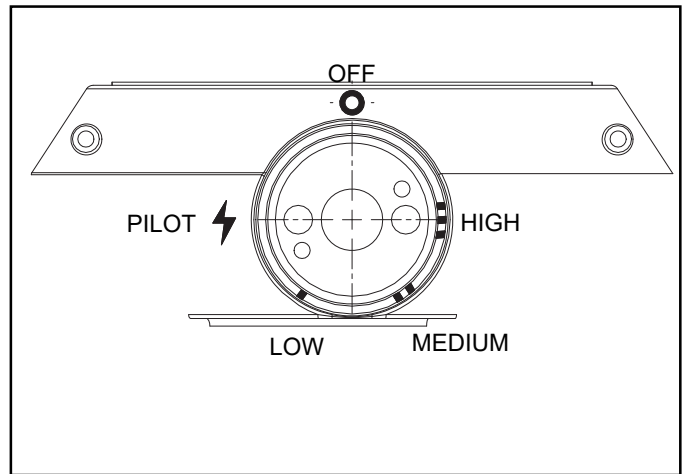

Fig. 2b - Model 18K Lighting Control Panel

LIGHTING / OPERATING INSTRUCTIONS FOR USE WITH HOSE(S) CONNECTED TO A REMOTE CYLINDER, MAXIMUM SIZE 20 LBS:

- This Heater may be used in a Recreational Enclosure or Temporary Construction Work Enclosure with a Remote Refillable Propane Cylinder ONLY when the Cylinder is Located Outdoors and the Heater is Used with WMAI Hose No. 20-7512F.
- WMAI Hose No. 20-7512F includes a hand-tightening tank connector, a fuel filter and a #600 hose connector fitting
- ⚠ **WARNING:** NEVER bring a refillable propane cylinder indoors. A fire or explosion can occur causing property damage, serious injury or death!
- Inspect the hose before each use of the heater. If there is excessive abrasion or wear or the hose is cut, replace prior to using the heater with WMAI 20-7512F.
- The propane cylinder must include a listed overfilling protection device as well as a collar to protect the cylinder valve.
- Heater must be in an upright position during operation.
- Connect propane as described on page 6.
- Open valve at LP-gas supply cylinder.
- Check all hose connections for leaks with soapy water at all threaded connection points and at the LP-gas supply cylinder. SEE WARNING! ON ATTACHED LABELS.
- Follow the instructions for lighting the Heater as defined in steps 1 through 8 above.

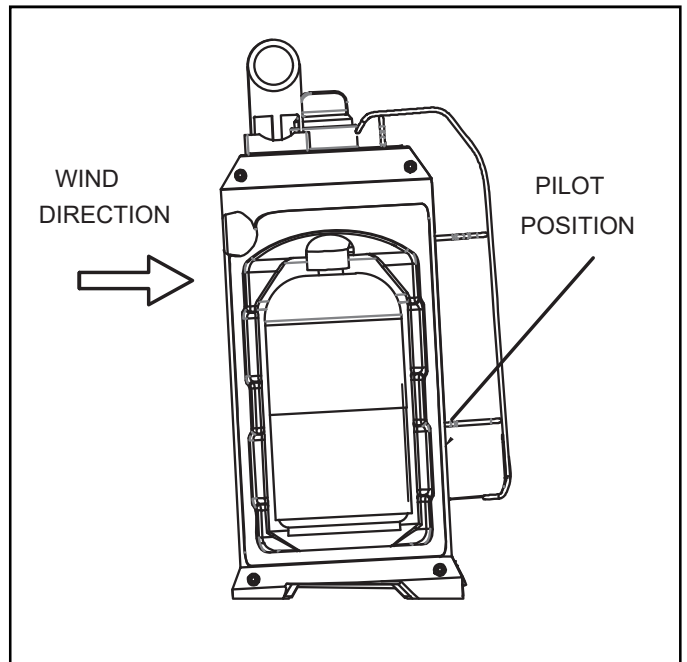

Fig. 3 - Lighting in Windy Areas

LIGHTING IN WINDY AREAS

1. Position the heater such that the Pilot is opposite the direction that the wind is coming from. See figure 3
2. Position your body behind the heater such that your body blocks the wind while you are following the instructions for lighting the unit.

NEVER LEAVE THE HEATER UNATTENDED WHILE BURNING!

IMPORTANT NOTICE

REGARDING THIRD PARTY ATTACHMENTS TO ALL WORLD MARKETING OF AMERICA, INC. PERSONAL PROPANE HEATERS

These heaters, which are sold by World Marketing of America, Inc.(WMAI), feature an Oxygen Depletion Sensor (“ODS”), which shuts off the heater if the oxygen in the room gets below a certain point, and a tip-over safety switch that turns it off in the event of it being knocked on its side. These features allow the heater to be safely used during numerous indoor and outdoor activities.

WMAI recognizes the many different third party attachments for the personal propane heater and is aware of their intended purpose of using the product to heat or cook food. WMAI strongly encourages that these third party attachments NOT be used as they are neither certified, nor safe to be used to warm or cook food of any kind. These Heaters are not certified as a cooker and are not designed to operate in this manner. WMAI explicitly prohibits the use of any type of non-approved attachments with its personal propane heaters.

WARNING:



This product is a heater. It is certified to **ANSI Z21.103-2017** Unvented portable type gas camp heaters for indoor and outdoor use.

This product is NEVER to be used for the cooking or warming of foods as doing so can interfere with the safety systems of the heater, which may result in a fire, explosion, the production of deadly carbon monoxide, and personal injury or death to you or others. NEVER use hand-made or third party accessories or attachments with this heater; this is extremely dangerous and may result in personal injury or death to you or others

WARRANTY LANGUAGE

WMAI warrants its heaters and accessories to be free from defects in material and workmanship for a period of 1-year from date of purchase. WMAI will repair or replace this product free of charge if it has been proven to be defective within the 1-year period and is returned at customer expense with proof of purchase to WMAI within the warranty period. **DISCLAIMER:** This warranty does not cover any product that: a) has been subject to misuse or neglect; b) has been used in a manner inconsistent with the warnings and instructions contained in the owner’s manual, including but not limited to using a heater for the cooking or warming of foods; or c) has been used with hand-made or third party accessories or attachments.

WMAI prohibits the personal propane heaters from being used for cooking or warming foods. Third party attachments intended to change the intended operation of the heaters are prohibited for use as they could cause serious harm to consumers. Using such products with WMAI heaters will immediately void the product warranty. WMAI values the safety of its consumers above all else and appreciates your continual trust in all WMAI products. Please feel free to contact us at info@worldmkting.com with any questions.

-  **CAUTION:** After turning heater off, wire guard will remain hot. Allow to thoroughly cool before moving or storing.
-  **CAUTION:** When not in use, the gas must be turned off at the LP-gas supply cylinder. As stated before, allow heater to use up propane in supply line until heater shuts off. When the LP-gas supply cylinder is not disconnected from the heater, the cylinder must be stored outdoors, in a well ventilated space, out of reach of children, and must not be stored in a building, garage or any other enclosed area. Disconnect all cylinders when heater is not in use.
-  **CAUTION:** Indoor storage of the heater is permissible only if the cylinder is disconnected and removed from the heater. Cylinders must be stored outdoors out of the reach of children and must not be stored in a building, garage or any other enclosed area. 1 lb. cylinders must be Dept. of Transportation (DOT) constructed and approved and have an outlet connection compatible with a CGA 600 fitting.

**NEVER LEAVE THE HEATER
UNATTENDED WHILE BURNING!**

MAINTENANCE:

Always keep the heater area clear and free from combustible materials, gasoline and other flammable vapors and liquids. Keep the vent areas (slots in the bottom and the top at the front of heater) clear at all times so combustion air and ventilation is not obstructed. Visually inspect the pilot flame and burner periodically during use so combustion air and ventilation is not obstructed. The pilot flame should be blue in color (not yellow) and will extend beyond the thermocouple. The flame will surround the thermocouple just below the tip, see Figure 5. A slight yellow flame may occur where the pilot flame and main burner flame meet. The burner(s) should be bright orange (with a slight blue color around the border, a red-orange haze that is visible on the burner is acceptable) and without a noticeable flame. A blue flame that rolls out at the top indicates an accumulation of dust, lint or spider webs inside the main burner assembly. If the pilot is yellow or the burner has a noticeable flame, cleaning may be required. Use the following procedure to inspect main burner assembly. It is necessary to periodically check the burner(s) orifice and burner venturi tube to make sure they are clear of insects/nests or spider webs that may accumulate over time. It is strongly recommended that these maintenance instructions be performed annually. A clogged tube can lead to a fire.

1. Allow heater to thoroughly cool before performing any maintenance.
2. Remove disposable 1 lb. cylinder(s) from heater or turn OFF gas supply at remote cylinder valve, and disconnect hose from heater.
3. Remove back panel by removing the top three screws, lower two rear screws and two screws behind the doors of the 18K.
4. Inspect interior of casing assembly for accumulation of dust, lint or spider webs. If necessary, clean interior of casing assembly with a vacuum cleaner or apply air pressure. Do not damage any components within casing assembly when you are cleaning.
5. Inspect and clean main burner orifice located at bottom of burner venturi tube by using a vacuum or apply air pressure at orifice opening.
6. Inspect and clean pilot (mounted to bracket) by using a vacuum or apply air pressure through the holes in the pilot indicated by the arrows in Figure 5.
WARNING: Never use needles, wires, or similar cylindrical objects to clean the pilot to avoid damaging the calibrated orifice that controls the gas flow.
7. Apply air pressure into burner assembly to remove dust, lint or spider webs.
8. Reinstall back panel.

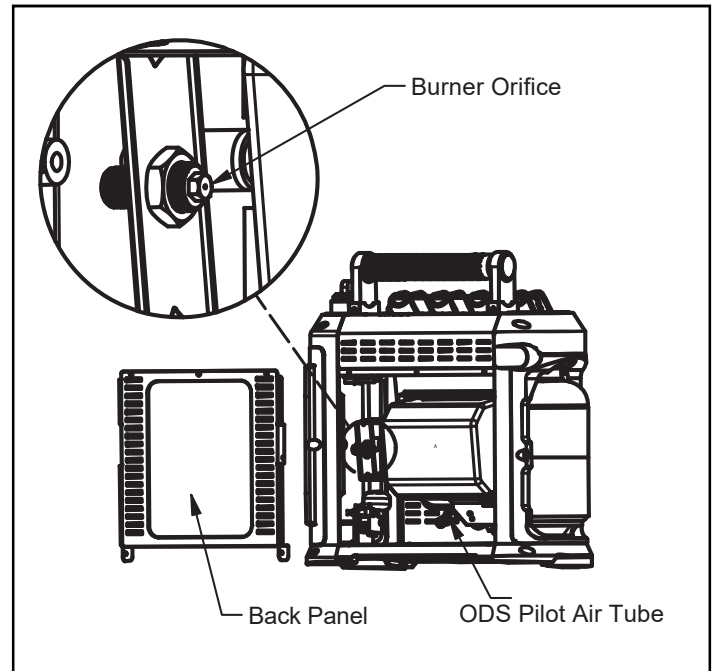

Fig. 4 Burner Orifice Location

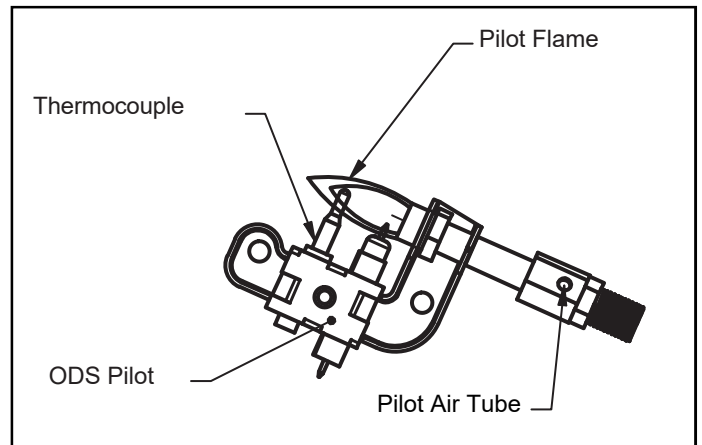

Fig. 5 - Pilot Assembly

**NEVER LEAVE THE HEATER
UNATTENDED WHILE BURNING!**

TROUBLESHOOTING

- ⚠ WARNING:** If you smell gas:
- Do not attempt to light appliance.
 - Extinguish any open flame.
 - Disconnect fuel supply.
 - Leave the area immediately.
 - Allow gas to dissipate 5 minutes before relighting the appliance

IMPORTANT: Operating heater where impurities in air exist may create odors. Cleaning supplies, paint, paint remover, cigarette smoke, cements and glues, new carpet or textiles, etc., create fumes. These fumes may mix with combustion air and create odors.

- ⚠ WARNING:** Turn off and let cool before servicing. Only a qualified service person should service and repair heater.

- ⚠ CAUTION:** Never use a wire, needle, or similar object to clean ODS/pilot. This can damage ODS/ pilot unit.

TROUBLESHOOTING

PROBLEM	POSSIBLE CAUSE	CORRECTIVE ACTION
When ignitor knob is turned, there is no spark at ODS/pilot.	<ol style="list-style-type: none"> 1. Ignitor electrode is positioned wrong. 2. Ignitor electrode is broken. 3. Ignitor electrode is not connected to ignitor cable. 4. Ignitor cable is pinched or wet. 5. Damaged ignitor cable. 	<ol style="list-style-type: none"> 1. Replace electrode. 2. Replace electrode. 3. Replace ignitor cable 4. Free ignitor cable if pinched by any metal or tubing. Keep ignitor cable dry. 5. Replace ignitor cable.
When ignitor knob is turned, there is a spark at ODS/ pilot but no ignition.	<ol style="list-style-type: none"> 1. Tank shutoff valve is closed. 2. Control knob not fully pressed in while pressing ignitor button. 3. Air in gas lines when installed. 4. ODS / pilot is clogged. 5. Control knob not in PILOT position. 6. Depleted gas supply (propane) 	<ol style="list-style-type: none"> 1. Turn on gas supply valve. 2. Fully press in control knob while pressing ignitor button. 3. Continue holding down control knob. Repeat igniting operation until air is removed. 4. Clean ODS/pilot (see Care and Maintenance on page 9) or replace ODS/pilot assembly. 5. Turn control knob to PILOT position. 6. Purchase new tank or refill 20 lb tank.
ODS/pilot lights but flame goes out when control knob is released.	<ol style="list-style-type: none"> 1. Control knob is not fully pressed in. 2. Control knob is not pressed in long enough. 3. Equipment shutoff valve is not fully open. 4. Thermocouple connection is loose. 5. Thermocouple damaged. 6. Control valve damaged. 	<ol style="list-style-type: none"> 1. Press in control knob fully. 2. After ODS/pilot lights, keep control knob pressed in 30 seconds. 3. Fully open equipment shutoff valve. 4. Hand tighten until snug, and then tighten ¼ turn more. 5. Replace thermocouple. 6. Contact customer service.
Burner(s) does not light after ODS/pilot is lit.	<ol style="list-style-type: none"> 1. Burner orifice is clogged. 2. Burner orifice diameter is too small. 3. Inlet gas pressure is too low. 	<ol style="list-style-type: none"> 1. Clean burner orifice (see Care and Maintenance on page 9) or contact customer service. 2. Contact customer service. 3. Change tanks.

NEVER LEAVE THE HEATER UNATTENDED WHILE BURNING!

PROBLEM	POSSIBLE CAUSE	CORRECTIVE ACTION
Burner backfiring during combustion.	<ol style="list-style-type: none"> 1. Burner orifice is clogged or damaged. 2. Burner is damaged. 3. Gas regulator is damaged. 	<ol style="list-style-type: none"> 1. Clean burner orifice (see Care and Maintenance on page 9) or contact customer service. 2. Contact qualified service technician. 3. Contact qualified service technician.
High yellow flame during burner combustion	<ol style="list-style-type: none"> 1. Not enough air. 2. Gas regulator is defective. 	<ol style="list-style-type: none"> 1. Check burner for dirt and debris. If found, clean burner (see Care and Maintenance on page 9). 2. Contact qualified service technician.
Gas odor during combustion.	<ol style="list-style-type: none"> 1. Foreign matter between control valve and burner. 2. Gas leak. (See Warning Statement on page 2). 	<ol style="list-style-type: none"> 1. Contact qualified service technician. 2. Locate and correct all leaks.
Heater produces a clicking/ticking noise just after burner is lit or shut off.	<ol style="list-style-type: none"> 1. Metal is expanding while heating or contracting while cooling. 	<ol style="list-style-type: none"> 1. This is common with most heaters. If noise is excessive, contact qualified service technician.
Heater shuts off in use (ODS operates).	<ol style="list-style-type: none"> 1. Not enough fresh air is available. 2. Low line pressure. 3. ODS/pilot is partially clogged. 	<ol style="list-style-type: none"> 1. Open window and/or door for ventilation. 2. Contact qualified service technician. 3. Clean ODS/pilot (see Care and Maintenance on page 9).
Gas odor exists even when control knob is in OFF position.	<ol style="list-style-type: none"> 1. Gas leak. See Warning Statement on page 2. 2. Control valve is defective. 	<ol style="list-style-type: none"> 1. Locate and correct all leaks (see "Checking Gas Connections" page 4). 2. Contact qualified service technician.
Moisture/condensation noticed on windows.	<ol style="list-style-type: none"> 1. Not enough combustion/ventilation air. 	<ol style="list-style-type: none"> 1. Refer to "Air for Combustion and Ventilation" requirements, page 4.
Slight smoke or odor during initial operation	<ol style="list-style-type: none"> 1. Residues from manufacturing process. 	<ol style="list-style-type: none"> 1. Problem will stop after a few hours of operation.

**NEVER LEAVE THE HEATER
UNATTENDED WHILE BURNING!**

PARTS LIST

ITEM	QTY	DESCRIPTION	MODEL NUMBERS
			PPH10
1	1	Back Panel	23-0010
2	1	Control Knob	23-1702
3	2	Handle Mount	23-5610
4	1	Handle Bar	23-5611
5	1	Wire Guard	23-5410
6	1	ODS Thermocouple	23-3011

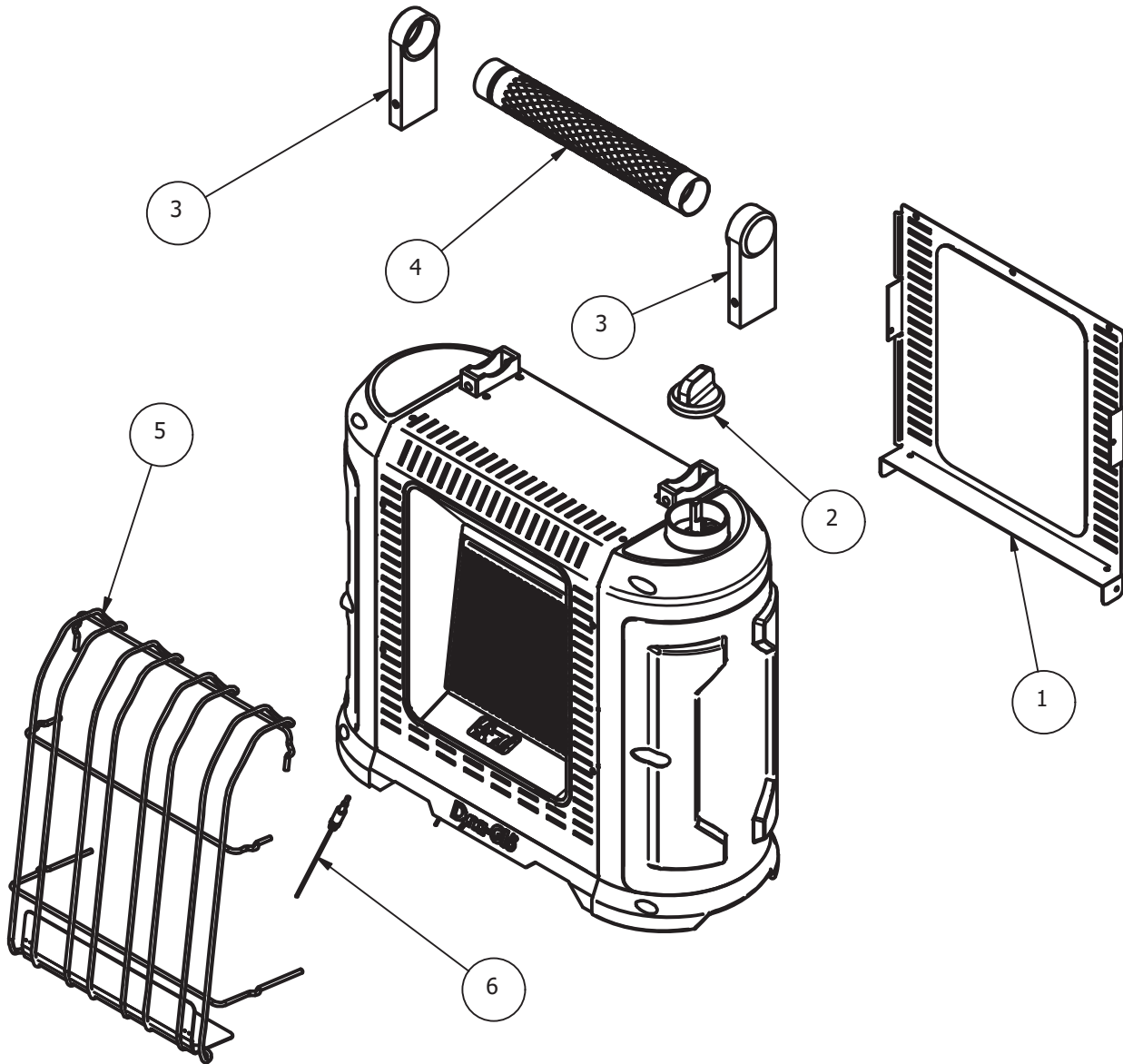

**NEVER LEAVE THE HEATER
UNATTENDED WHILE BURNING!**

PARTS LIST

ITEM	QTY	DESCRIPTION	MODEL NUMBERS PPH18
1	1	Back Panel	23-0018
2	1	Control Knob	23-1702
3	1	Handle Bar	23-5613
4	1	Wire Guard	23-5418
5	2	Handle Mount	23-5612
6	1	Door, LH	CALL FOR INFORMATION
7	1	Door, RH	CALL FOR INFORMATION
8	1	ODS Thermocouple	23-3012

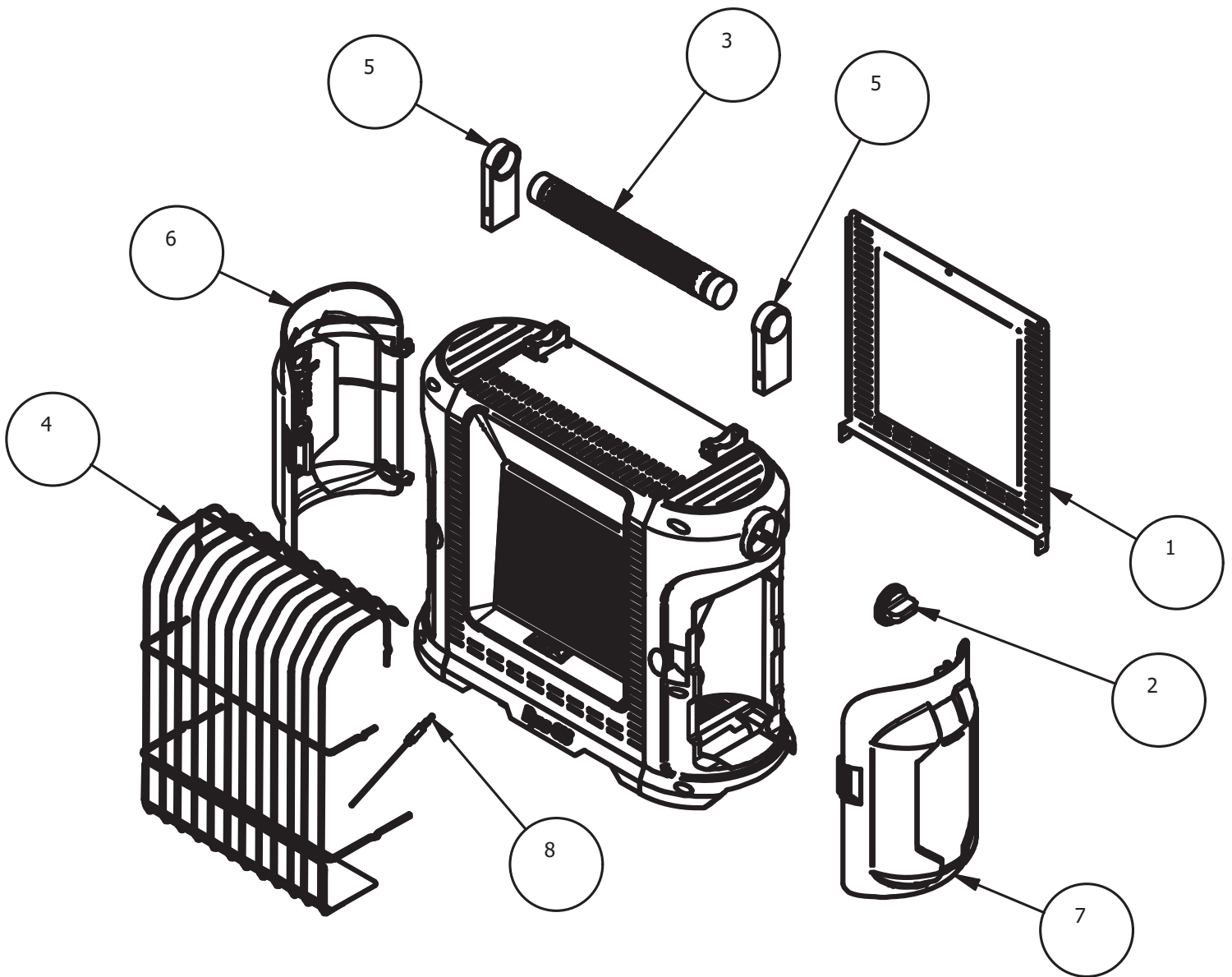



LIMITED WARRANTY:

This limited warranty is extended to the original retail purchaser of this Forced Air/Convection/Radiant Heater and warrants against any defect in materials and workmanship for a period of one (1) year from the date of retail sale. World Marketing of America, Inc. (WMAI) at it's option, will either provide replacement parts or replace or repair the unit, when properly returned to the retailer where purchased or one of our service centers as directed by WMAI within one (1) year of retail purchase. (Shipping costs, etc. are the responsibility of the purchaser.)

DUTIES OF THE OWNER:

This heating appliance must be operated in accordance with the written instructions furnished with this heater. This warranty shall not excuse the owner from properly maintaining this heater in accordance with the written instructions furnished with this heater. A bill of sale, canceled check or payment record must be kept to verify purchase date and establish warranty period. Original carton should be kept in case of warranty return of unit.

WHAT IS NOT COVERED:

1. Damage resulting from use of improper fuel.
2. Damage caused by misuse or use contrary to the owners manual and safety guidelines.
3. Damage caused by a lack of normal maintenance.
4. Use of non-standard parts or accessories.
5. Damage caused in transit. Freight charges on warranty parts or heaters to and from the factory shall be the responsibility of the owner.

This warranty does not imply or assume any responsibility for consequential damages that may result from the use, misuse, or the lack of routine maintenance of this heating appliance. A cleaning fee and the cost of parts may be charged for appliance failures resulting from lack of maintenance. This warranty does not cover claims which do not involve defective workmanship or materials. **FAILURE TO PERFORM GENERAL MAINTENANCE (INCLUDING CLEANING) WILL VOID THIS WARRANTY.**

THIS LIMITED WARRANTY IS GIVEN TO THE PURCHASER IN LIEU OF ALL OTHER WARRANTIES, EXPRESSED OR IMPLIED, INCLUDING BUT NOT LIMITED TO THE WARRANTIES OF MERCHANTABILITY OF FITNESS FOR A PARTICULAR PURPOSE. THE REMEDY PROVIDED IN THIS WARRANTY IS EXCLUSIVE AND IS GRANTED IN LIEU OF ALL OTHER REMEDIES. IN NO EVENT WILL WMAI. BE LIABLE FOR INCIDENTAL OR CONSEQUENTIAL DAMAGES.

Some states do not allow limitations on how long an implied warranty lasts, so the above limitation may not apply to you. Some states do not allow the exclusion or limitation of incidental or consequential damages so the above limitation or exclusion may not apply to you.

CLAIMS HANDLED AS FOLLOWS:

1. Contact your retailer and explain the problem.
2. If the retailer is unable to resolve the problem, contact our Customer Service Dept. detailing the heater model, the problem, and proof of date of purchase.
3. A representative will contact you. DO NOT RETURN THE HEATER TO WMAI unless instructed by our Representative. This warranty gives you specific legal rights and you may also have other rights which vary from state to state.

TO REGISTER THE WARRANTY ON YOUR HEATER, PLEASE FILL OUT THIS CARD COMPLETELY AND MAIL WITHIN 14 DAYS FROM DATE OF PURCHASE OR REGISTER ON-LINE AT www.worldmktng.com

NAME: _____ PHONE: () _____ EMAIL: _____
ADDRESS: _____ CITY: _____ STATE: _____ ZIP: _____
MODEL: _____ SERIAL #: _____ DATE PURCHASED: _____
DEALER PURCHASED FROM: _____ TYPE OF STORE: _____
CITY & STATE WHERE PURCHASED: _____ PRICE PAID: _____

Please Take a Minute To Give Us Your Answers To The Following Questions.

All Responses Are Used Solely For Market Research And Are Held In Strict Confidence.

Who primarily decided this purchase? Male Female 18-24 25-39 40-59 60 and over
Purpose of Purchase? _____
Do you own any other portable heaters? Yes No If yes, type _____ brand _____
How do you intend to use your new heater? Construction Site Farm Warehouse/Commercial Garage/Outbuilding Other
How did you become aware of this heater? In-Store Display Newspaper Ad Magazine Ad Friend/Relative
 TV Commercial Store Salesperson Other _____
What made you select this heater? Style Size/Portability Price Package Brand Other _____
Do you: own rent Would you recommend this heater to a friend? Yes No
Please give us your comments: _____

THANK YOU FOR COMPLETING THIS FORM!
Information will be held confidential.

WARRANTY REGISTRATION

IMPORTANT: We urge you to fill out your warranty registration card within fourteen (14) days of date of purchase. You can also register your warranty on the internet at www.worldmkting.com. Complete the entire serial number. Retain this portion of the card for your records.

World Marketing of America, Inc.

PO Box 192

Mill Creek PA 17060-0192

Tel) 1-814-643-1775

www.worldmkting.com

SAVE THIS CARD!

Place
Postage
Stamp
Here

World Marketing of America, Inc.

PO Box 192

Mill Creek PA 17060-0192

REGISTRO DE GARANTÍA

IMPORTANTE: Le recomendamos que complete su tarjeta de registro de garantía dentro de los catorce (14) días posteriores a la fecha de compra. También puede registrar su garantía en Internet en www.worldmkting.com. Complete el número de serie completo. Conserve esta parte de la tarjeta para sus registros.

World Marketing of America, Inc.

PO Box 192

Mill Creek PA 17060-0192

Tel) 1-814-643-1775

www.worldmkting.com

¡GUARDE ESTA TARJETA!

Coloque aquí
el sello postal

World Marketing of America, Inc.

PO Box 192

Mill Creek PA 17060-0192