

QUEEN BED

Read these instructions carefully. See hardware and furniture part list for guidance. Be sure all part is complete, before you assemble. Place all wooden furniture part on a clean and flat soft surface to prevent from being scratched. Follow the figure to start assembling.

CAUTION:

1. Do not FULLY-TIGHTEN the nut or bolt untill all nut or nut bolt is ready to assembled.
2. Do not OVER-TIGHTEN the nut or nut bolt to avoid causing damages to the thread.
3. Keep all hardware part out of reach of children.

PART LIST

NO	DESCRIPTION	QTY
1	HEADBOARD	1 PC
2	FOOTBOARD	1 PC
3	SIDE RAIL	2 PCS
4	CENTER RAIL	1 PC
5	SUPPORT LEG	3 PCS
6	SLAT	13 PCS
7	HEADBOARD LEG	2 PCS
8	FOOTBOARD LEG	2 PCS

HARDWARE LIST

NO	DESCRIPTION	QTY
A	JCBB M8 X 40MM	14PCS
B	JCBB M8 X 100MM	4PCS
C	JCBC M6 X 35MM	6PCS
D	SPRING WASHER 5/16"	24PCS
E	FLAT WASHER 5/16"	18PCS
F	FLAT WASHER 1/4"	6PCS
G	CSK M4 X 30MM	33PCS
H	ALLEN KEY M4	1 PC
I	ALLEN KEY M5 with ball	1 PC

STEP 1

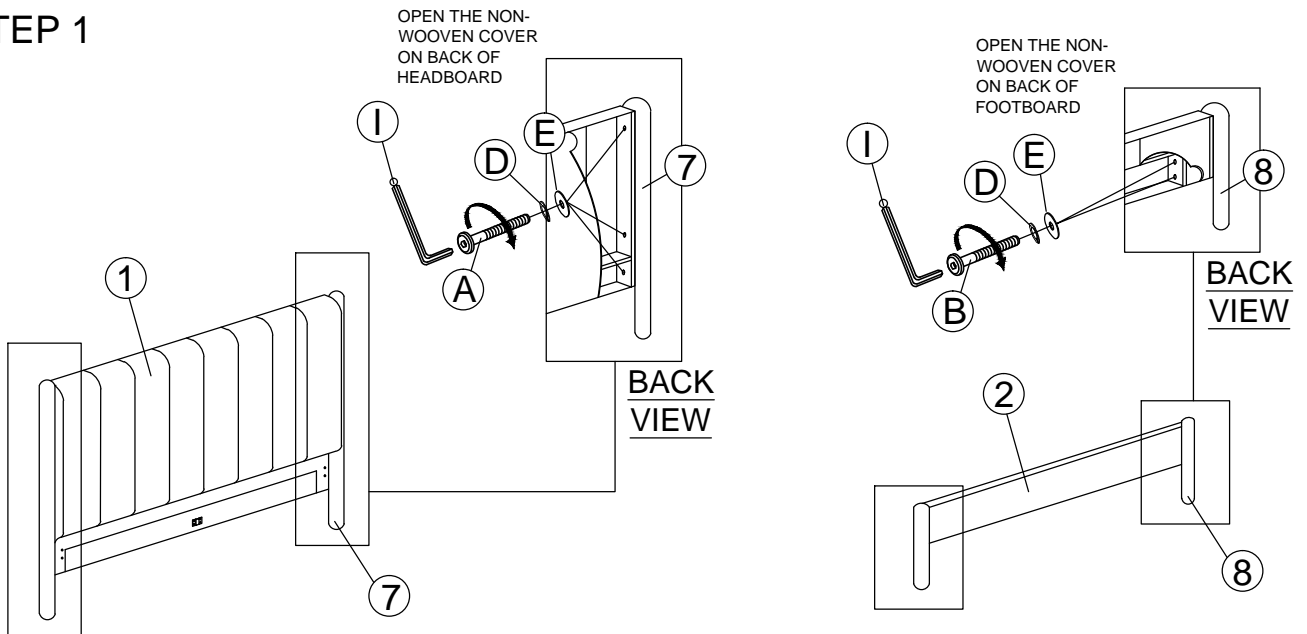

STEP 2

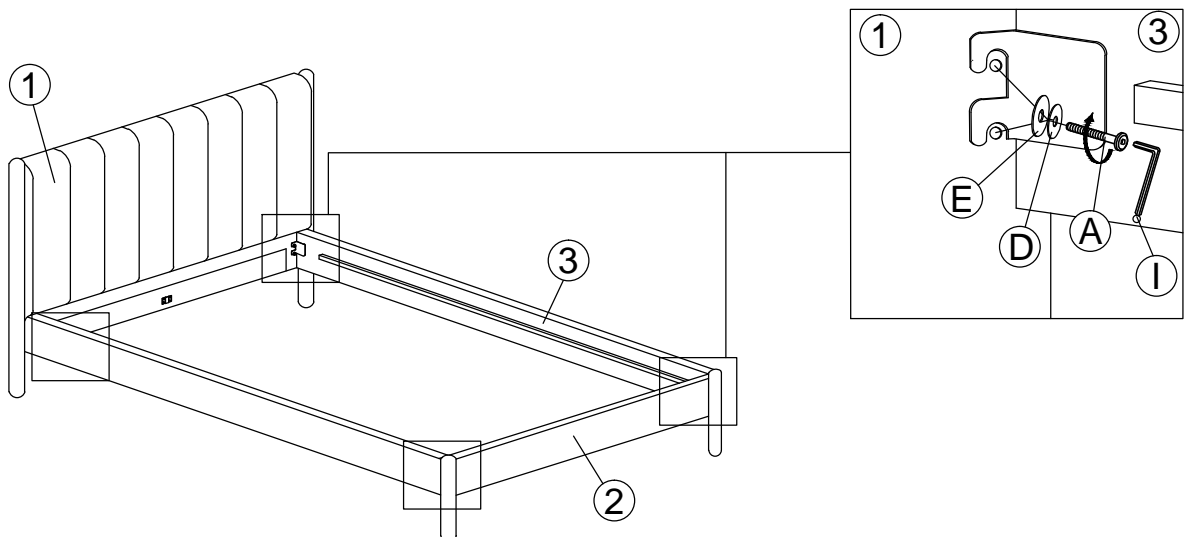

STEP 3

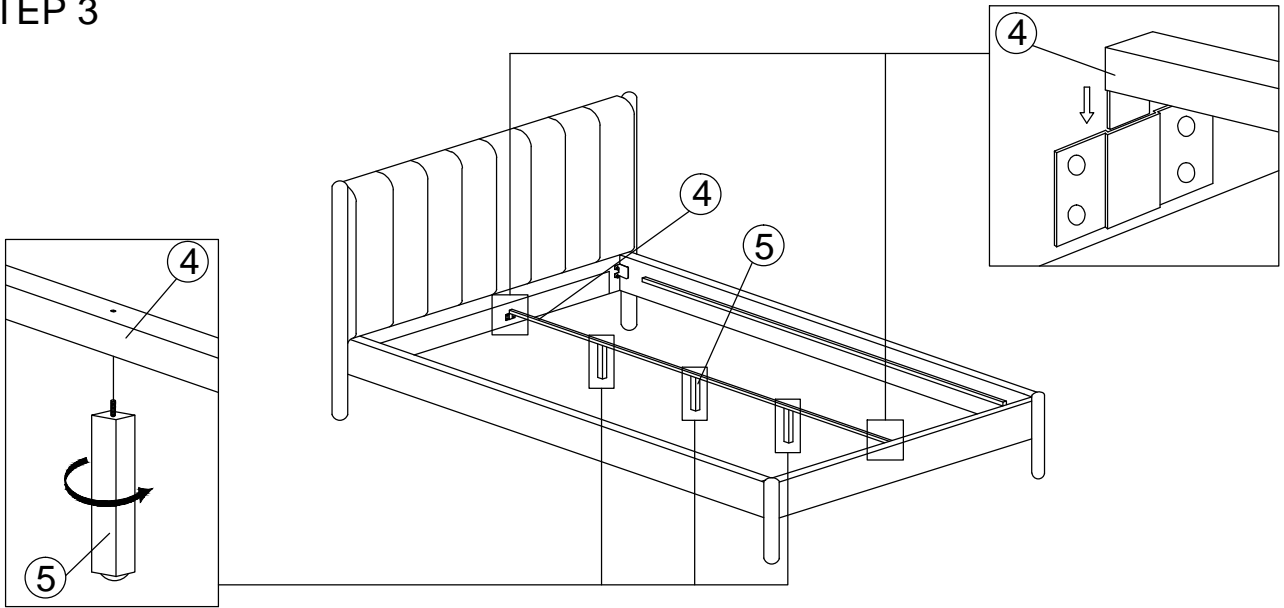

STEP 4

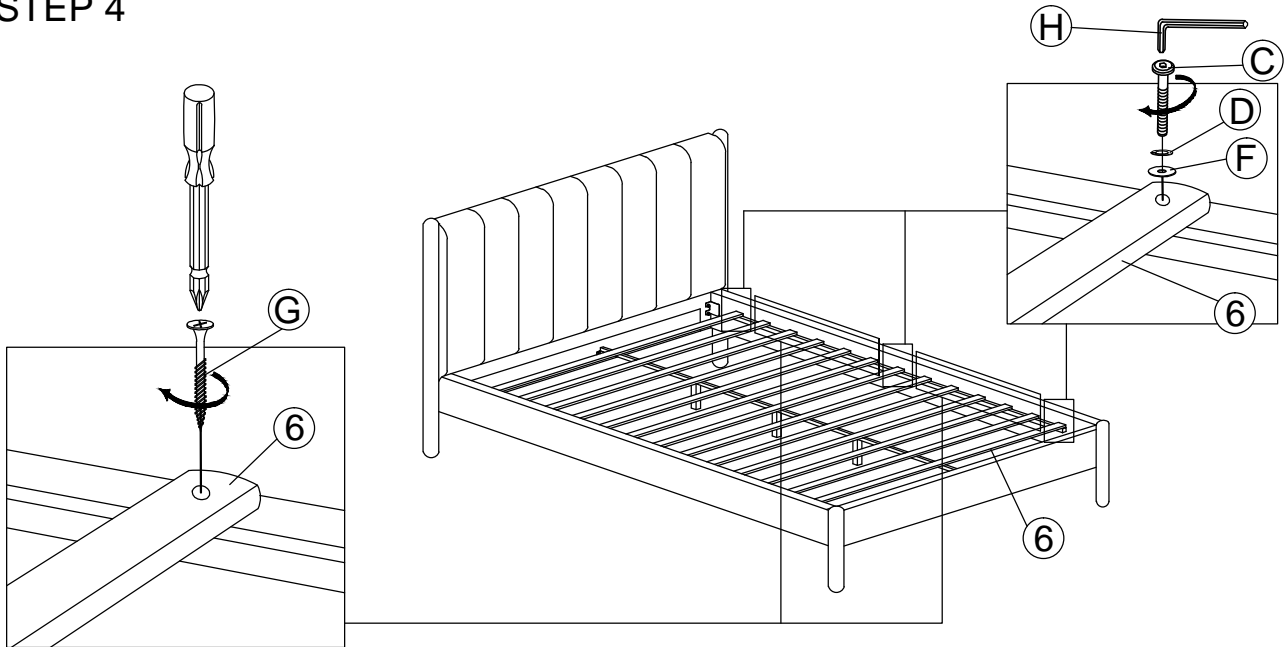

STEP 5

