

SHOWER STOOL

Instruction Manual

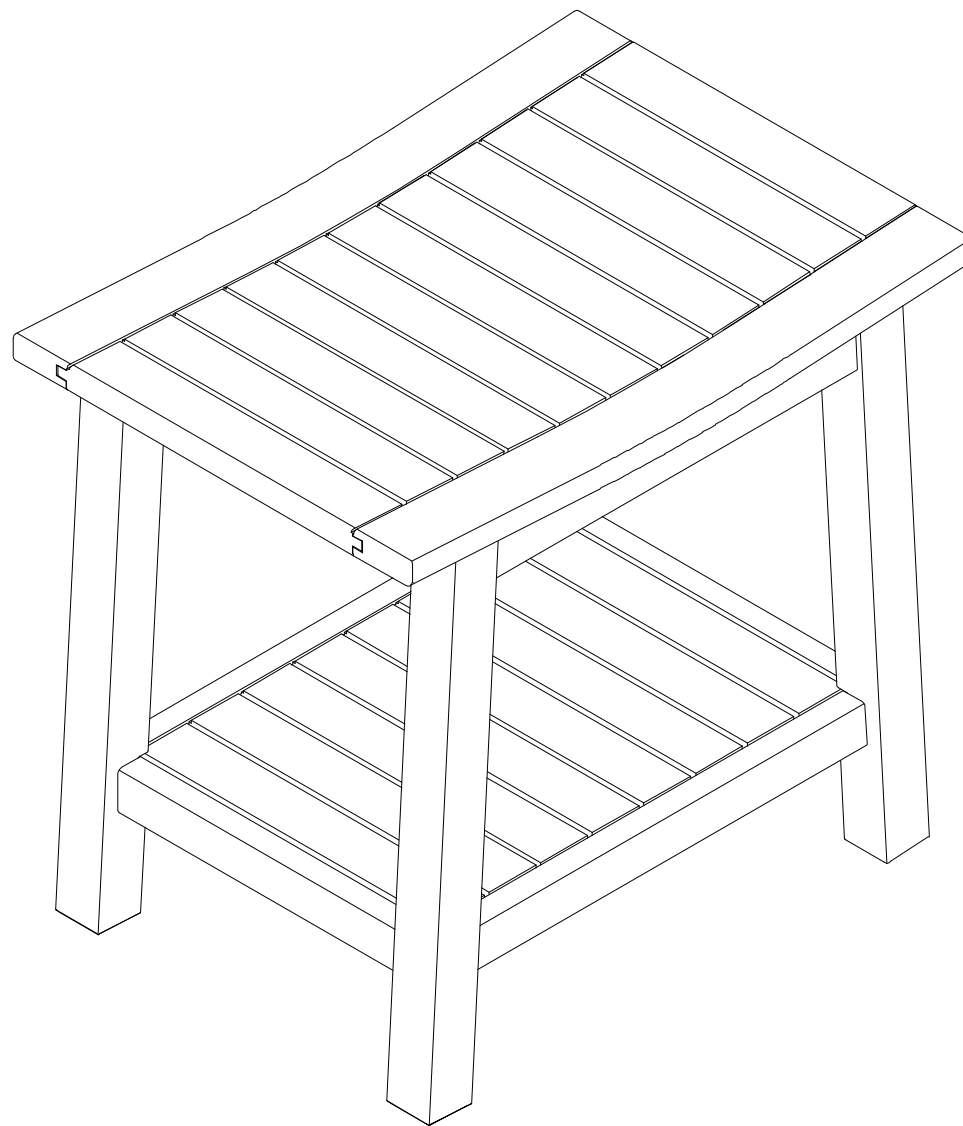

ASSEMBLY INSTRUCTIONS

PARTS & HARDWARE LIST:

NO	PARTS LIST	Q'TY
1	STOOL TOP	1 PC
2	SHELF	1 PC
3	LEGS	4 PCS

NO	HARDWARE LIST	Q'TY
A	Bolt (Ø13*Ø1/4"*50mm)	8 Pcs
B	Spring Washer (Ø1/4"*13mm *1.5mm)	8 Pcs
C	Flat Washer (Ø1/4"*16mm *1.5mm)	8 Pcs
D	Allen Key (4x100 mm)	1 Pc

ASSEMBLY - LEGS TO STOOL TOP AS SHOWN

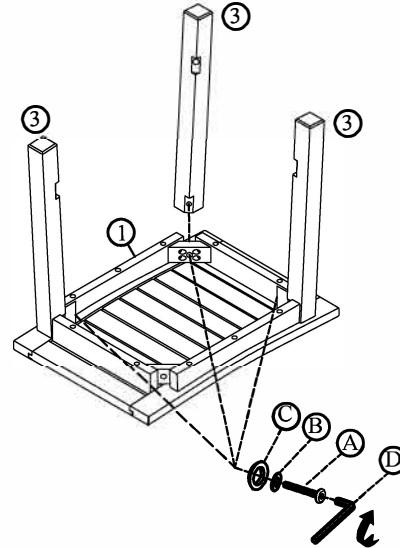

STEP 1

ASSEMBLY - SHELF TO LEGS AS SHOWN

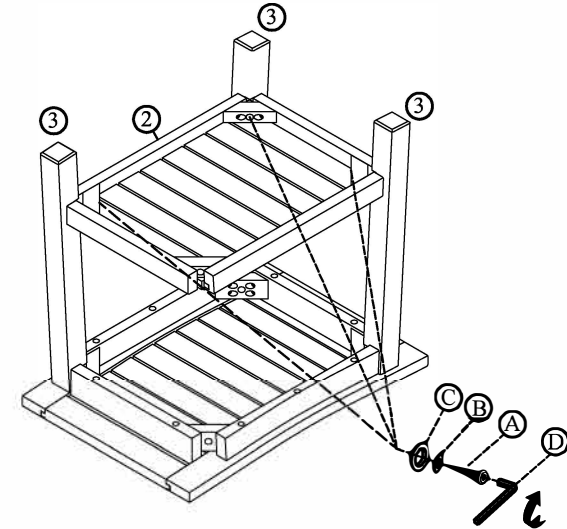

STEP 2

ASSEMBLY - LEG (3) TO TOP AND SHELF

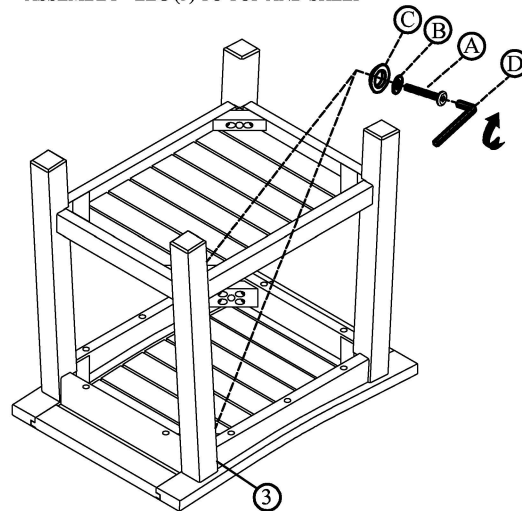

STEP 3

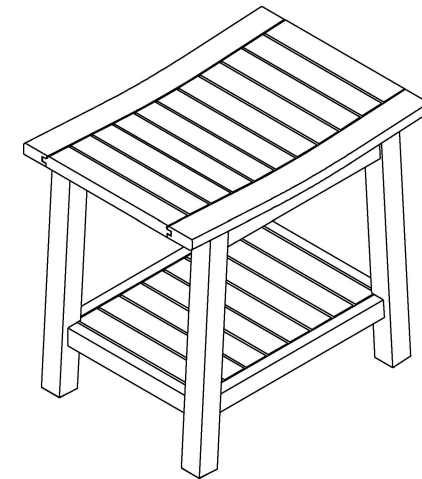

ASSEMBLY COMPLETE

Allen Wrench



Phillips Head Screwdriver

Tools Required



Allen Wrench



Maintenance Manual

No manufacturing process or wood species can entirely prevent cracking, but maintaining proper environmental conditions will significantly reduce its occurrence probability.

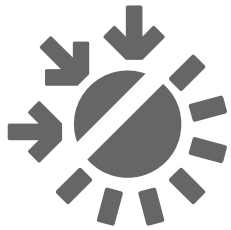

Protect from prolonged direct sunlight exposure

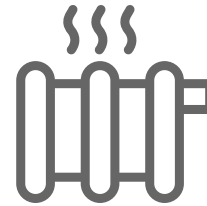
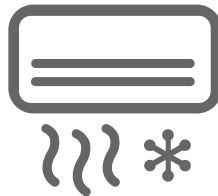

Position away from air conditioning vents and heating radiators

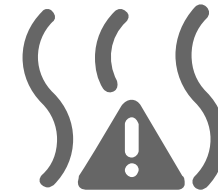

Avoid contact with high-temperature surfaces



Promptly wipe away surface liquid stains

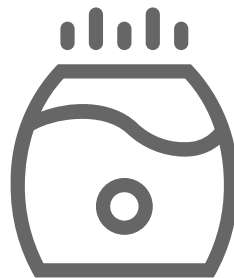

- ① Use humidifiers during arid winter periods
- ② Maintain optimal humidity at 60% RH
- ③ Avoid direct airflow from vents onto wood surfaces