

# ASSEMBLY INSTRUCTIONS

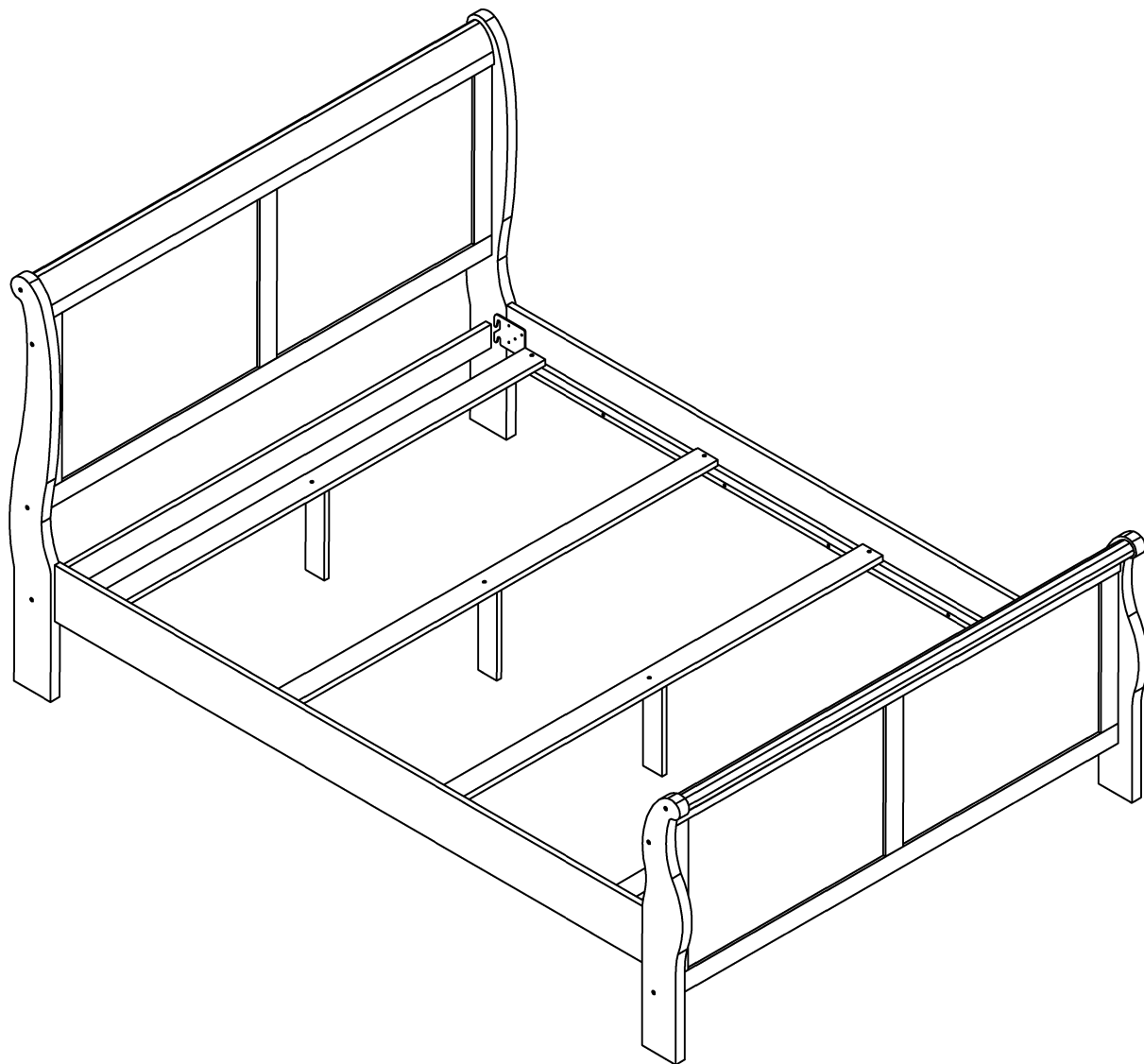

Description : Queen Bed

Dimension : 2343 x 1600 x 1215

## BEFORE ASSEMBLY

Thank you for purchasing this quality product. This product has been designed for easy assembly and constructed for durability. Please take the time to read and follow the assembly instructions carefully.





Be sure to check all packing material carefully for small parts which may have come loose inside the carton during shipment. Please separate, identify, and count all parts and metal hardware. Compare with part list to be sure all parts are present.

If hardware is missing or you have difficulty assembling this product, please call for us.

**IMPORTANT NOTE:**

- Place all wooden parts on a clean and smooth surface such as a rug or carpet to avoid the parts from being scratched.
- Remove all wrapping material, including staples & packing straps before you start to assemble.
- DO NOT tighten all screws and bolts until completely assembled.
- Keep all hardware parts out of reach of children.

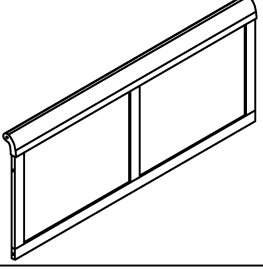
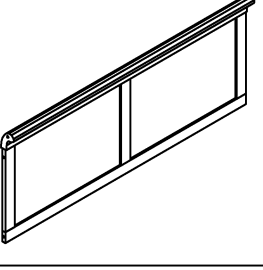
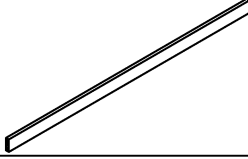
## PART LIST

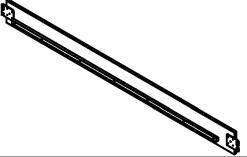
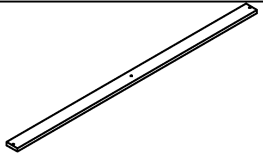
NO	Description	Q'Ty	Sketch	NO	Description	Q'Ty	Sketch
A	Left headboard post	1		B	Right headboard post	1	
C	Headboard panel	1		D	Footboard panel	1	
E	Support bar	1		F	Left footboard post	1	
G	Right footboard post	1	- 	H	Side rails	2	
I	Slats	1		K	Center support legs	4	

## HARDWARE LIST

NO	Description	Q'Ty	Sketch	NO	Description	Q'Ty	Sketch
1	Head hex bolts 1/4" x 35mm	10	! (upside down)	2	Head hex bolts 1/4" x 65mm	4	! (upside down)
3	Screws ø8 x 35mm	8		4	Screws ø8 x 45mm	4	
5	Wood Dowels ø8 x 30mm	4		6	Wood corks ø15 x 10mm	14	( )
7	Alen key	1		8	Dowel nuts ø10x1/4"x10mm	4	

### STEP 1 : Assembly headboard

Assembly left & right post (A&B) with Headboard (C) and horizontal support bar (E) by bolts (1) and screws (4).

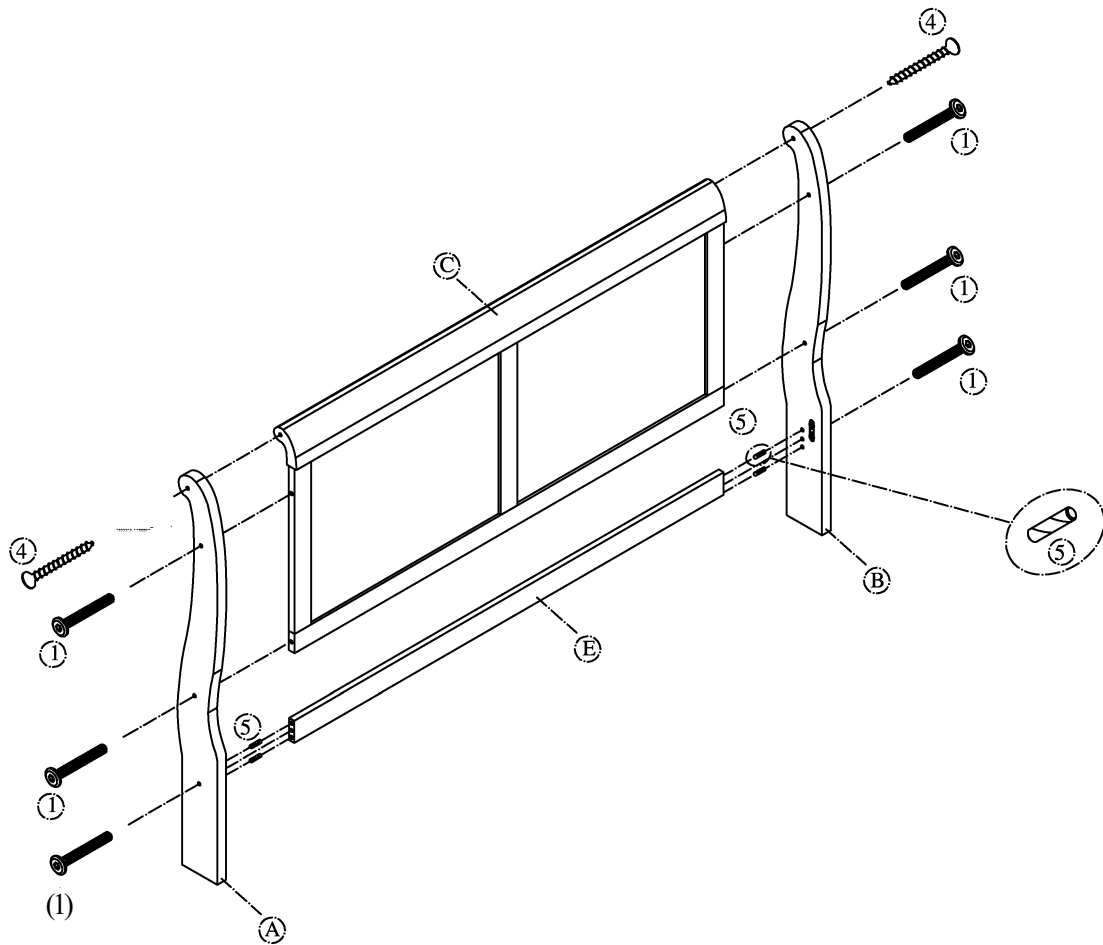

## STEP 2 : Assembly footboard

Assembly left & right post (F&G) with footboard (D) by bolts (1) and screws (4)

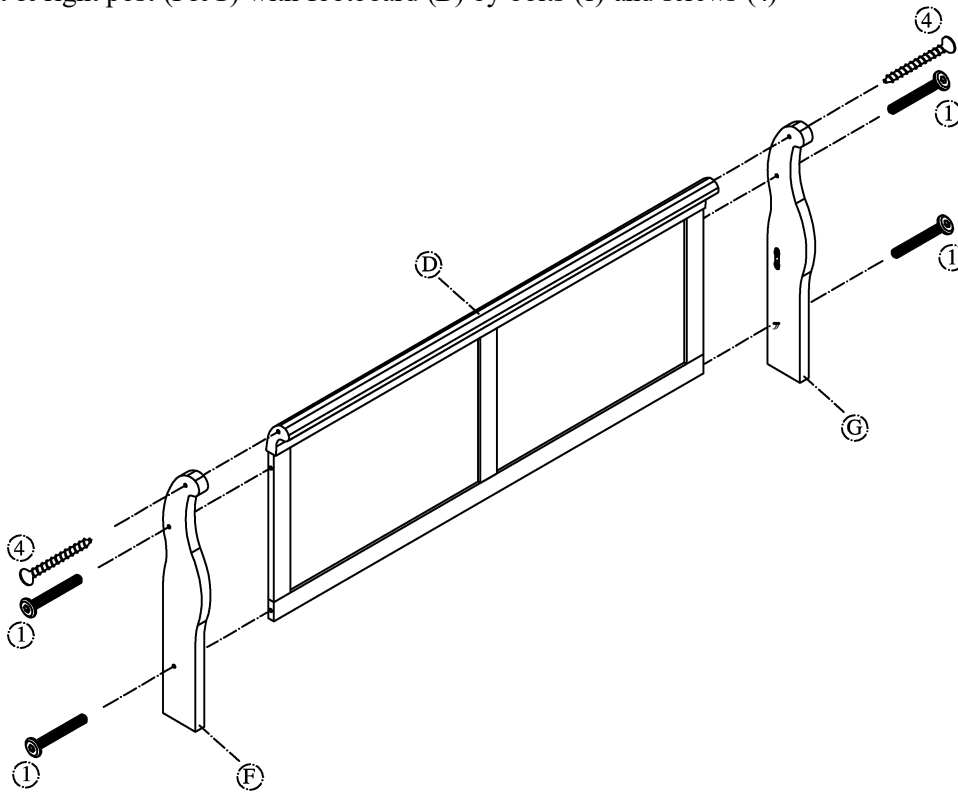

## STEP 3 : Assembly side rails

Assembly headboard and footboard with side rails (H). Tighten all bolts and insert corks (6).

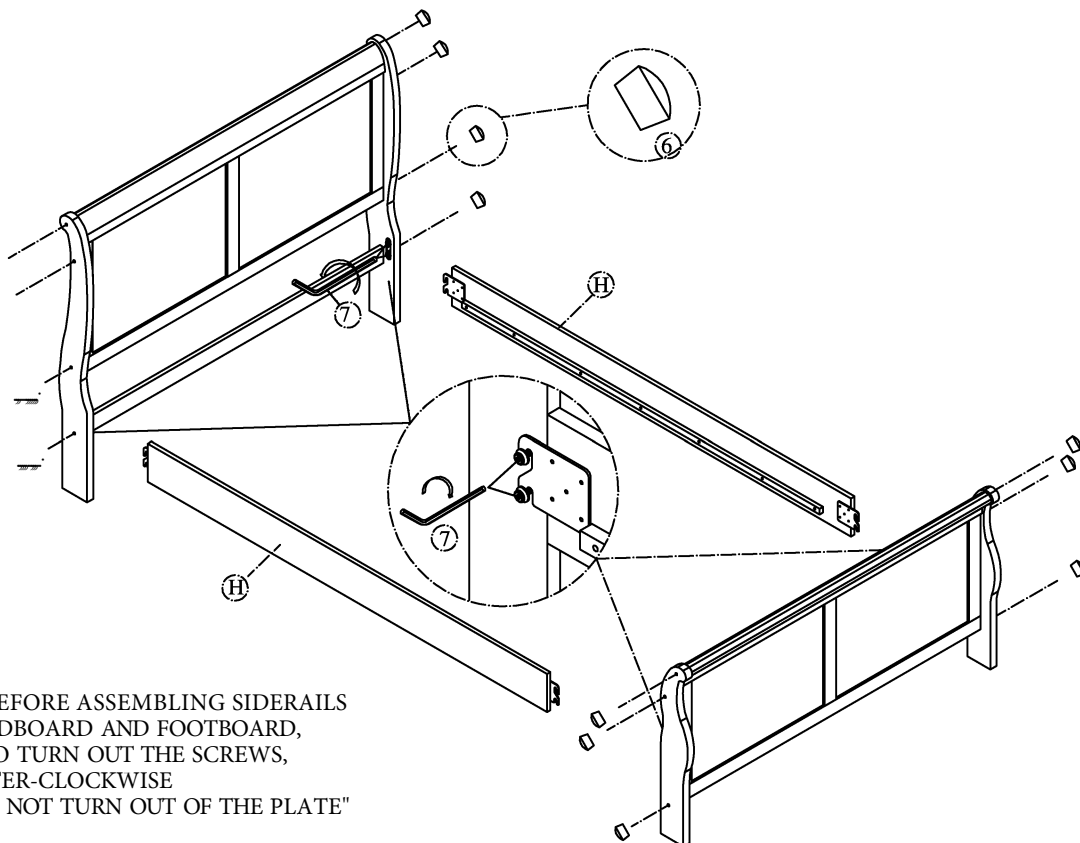

NOTE: BEFORE ASSEMBLING SIDERAILS TO HEADBOARD AND FOOTBOARD, NEED TO TURN OUT THE SCREWS, "COUNTER-CLOCKWISE AND DO NOT TURN OUT OF THE PLATE"

## STEP 4: Assembly support legs

Use alen key (7) assembly support legs (K) with Slats (I) by bolts (2) and nuts (8)

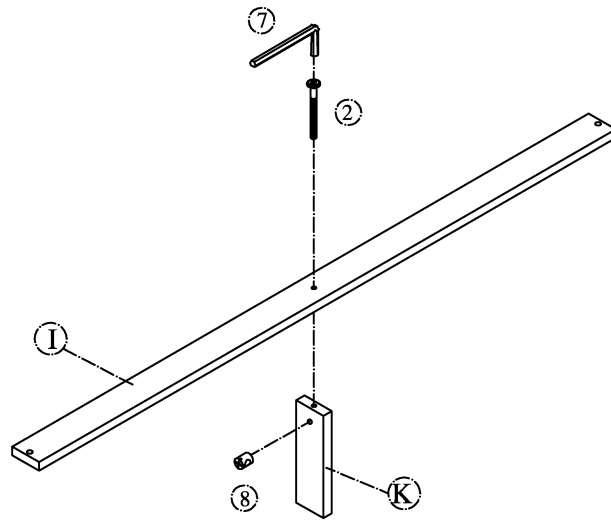

## STEP 5 : Fix slats

Use screwdriver fix Slats (I) on side rails (H) by screws (3)

