

ASSEMBLY INSTRUCTION

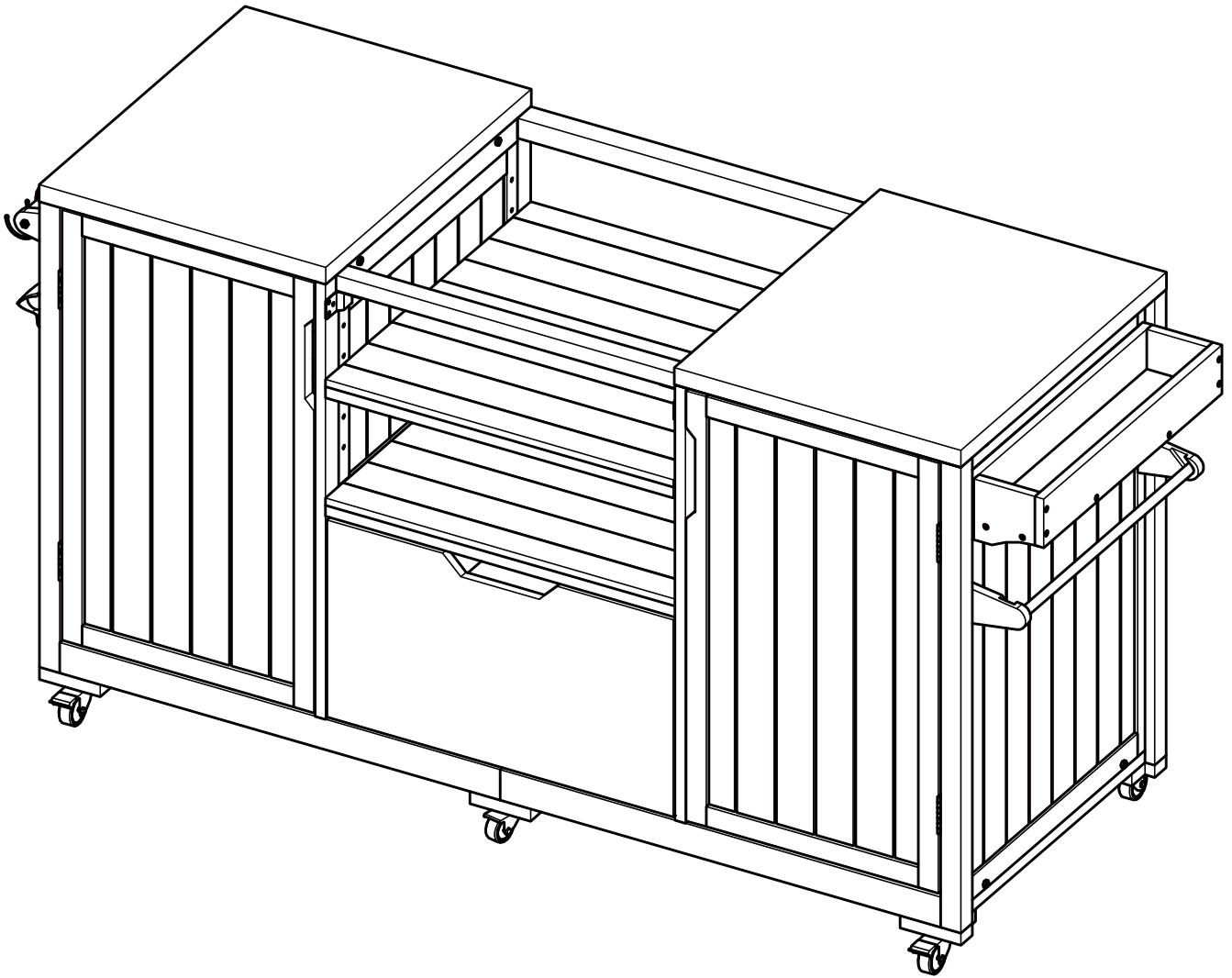







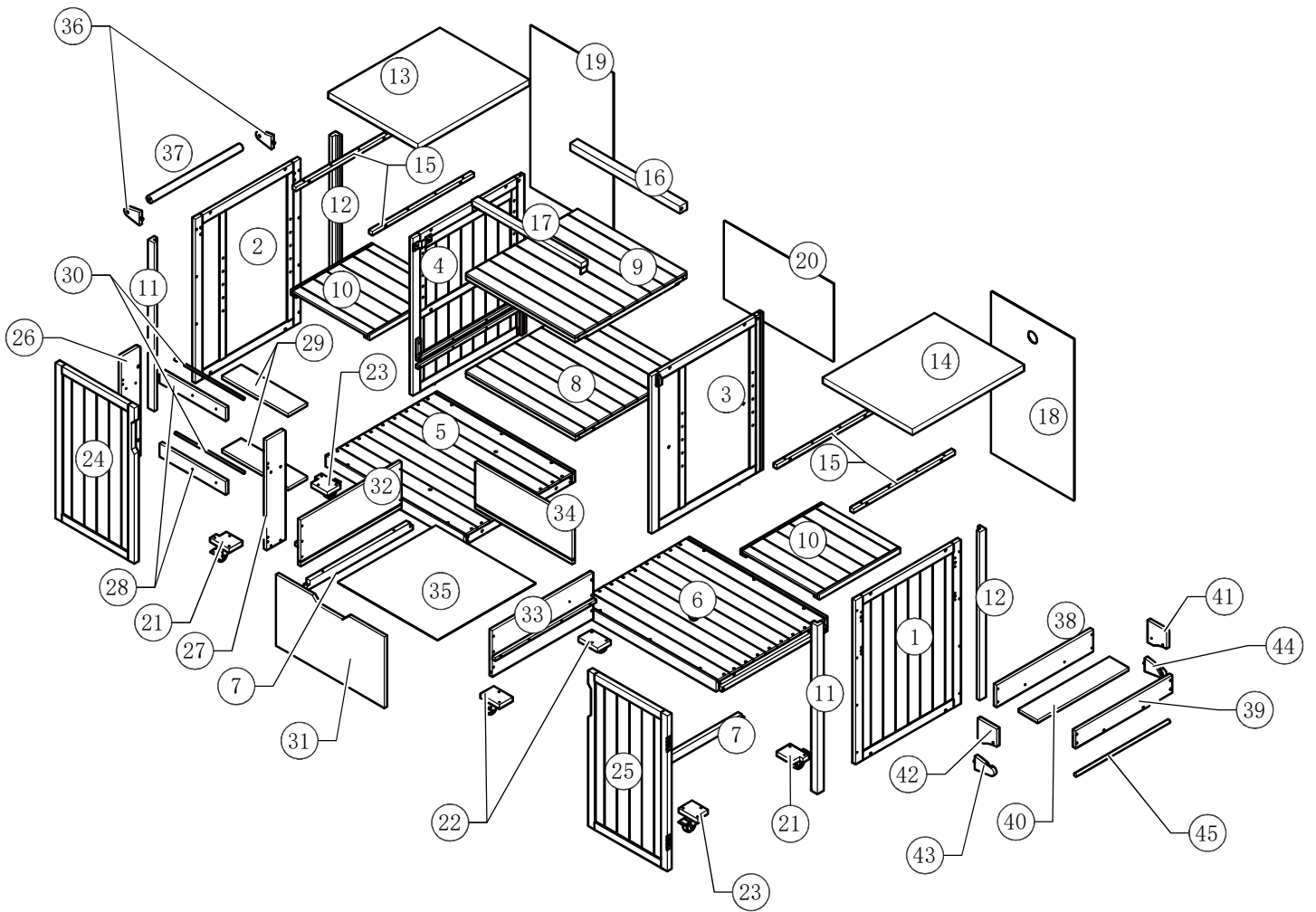





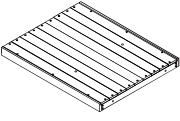
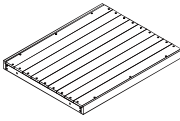
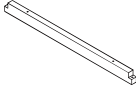
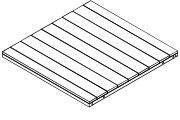

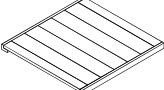

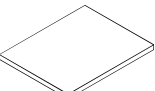
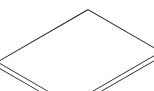

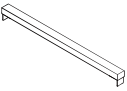
IMPORTANT NOTE:

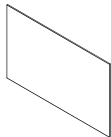
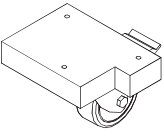
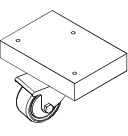
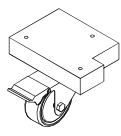

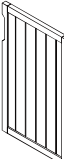

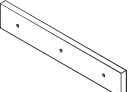

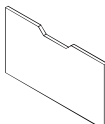
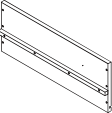
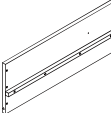
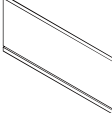
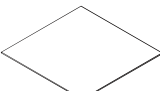
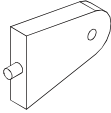
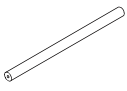
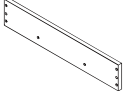
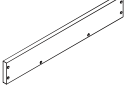
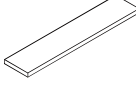
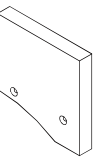
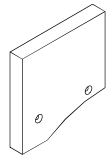
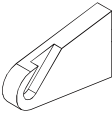
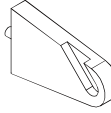
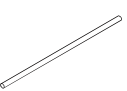



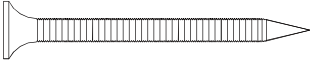
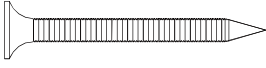
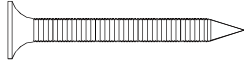
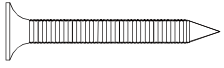

- ① PLACE ALL PARTS ON A CLEAN AND SMOOTH SURFACE SUCH AS A RUG OR CARPET TO AVOID THE PARTS FROM BEING SCRATCHED.
- ② BEFORE YOU BEGIN, KINDLY FOLLOW THE ASSEMBLY INSTRUCTIONS STEP BY STEP.
- ③ DO NOT TIGHTEN ALL SCREWS AND BOLTS UNTIL THIS ITEM IS FULLY SET-UP.

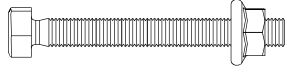
DETAIL VIEW

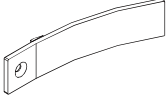

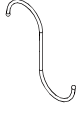
1		1PC	2		1PC	3		1PC	4		1PC
5		1PC	6		1PC	7		2PCS	8		1PC
9		1PC	10		2PCS	11		2PCS	12		2PCS
13		1PC	14		1PC	15		4PCS	16		1PC
17		1PC	18		1PC	19		1PC	20		1PC
21		2PCS	22		2PCS	23		2PCS	24		1PC
25		1PC	26		1PC	27		1PC	28		2PCS
29		2PCS	30		2PCS	31		1PC	32		1PC
33		1PC	34		1PC	35		1PC	36		2PCS
37		1PC	38		1PC	39		1PC	40		1PC
41		1PC	42		1PC	43		1PC	44		1PC
45		1PC									

HARDWARE LIST

 A M3.5*60(4PCS)	 B M3.5*40(34PCS)	 C M3.5*35(16PCS)
 D M3.5*30(16PCS)	 E M3.5*25(2PCS)	 F M3.0*28(50PCS)
 G M3.0*18(12PCS)	 H M3.0*10(2PCS)	 I M6*45(6PCS)
 J M6*40(12PCS)	 K 1PC	 L 2PCS
 M 1PC	 N 5PC	 O 12PCS
 P M6*40(4PCS)	 Q 1PC	



PLEASE BE CAREFUL DO NOT DAMAGE THE HOLE POSITION WHEN YOU USE POWERTOOLS

1

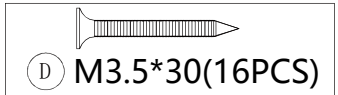
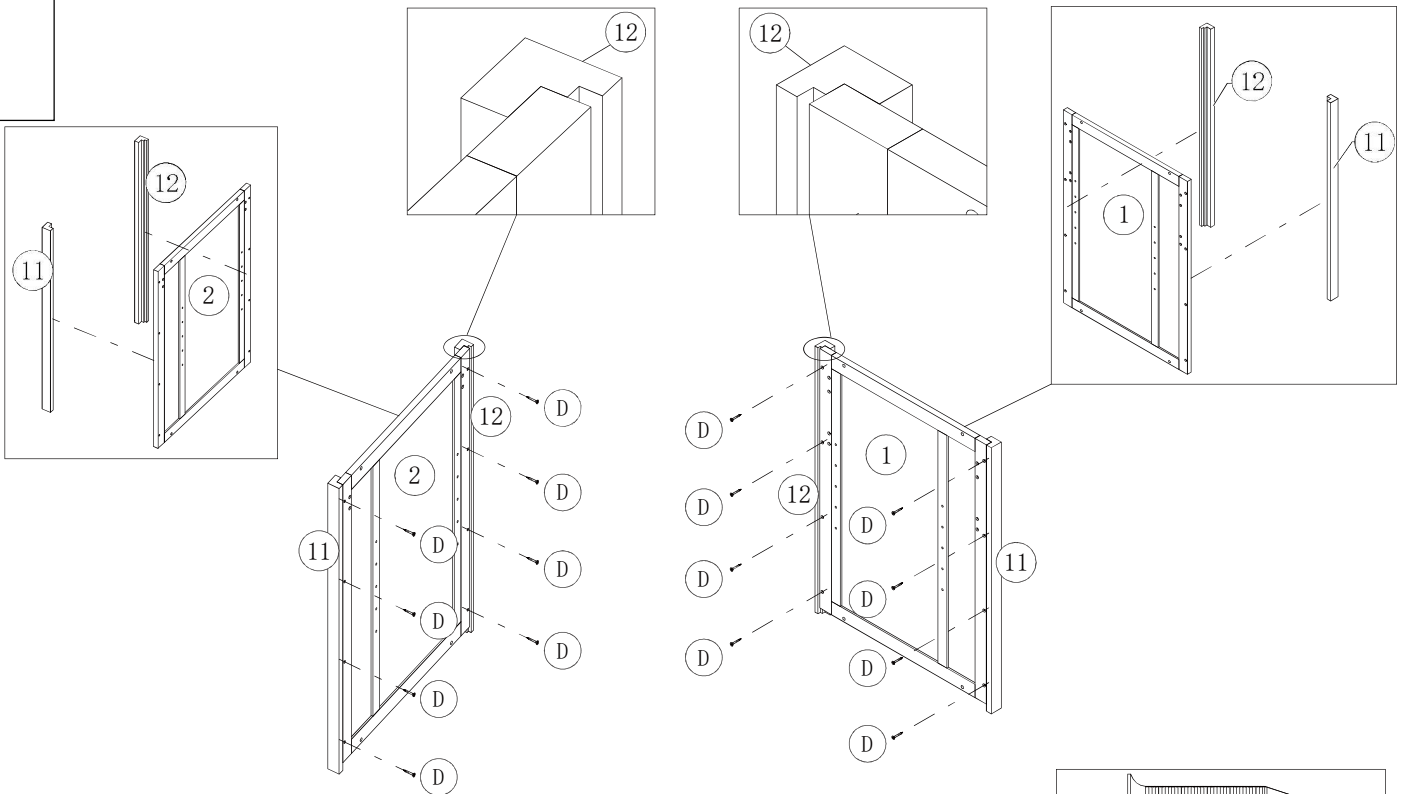

2

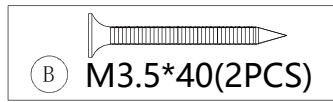
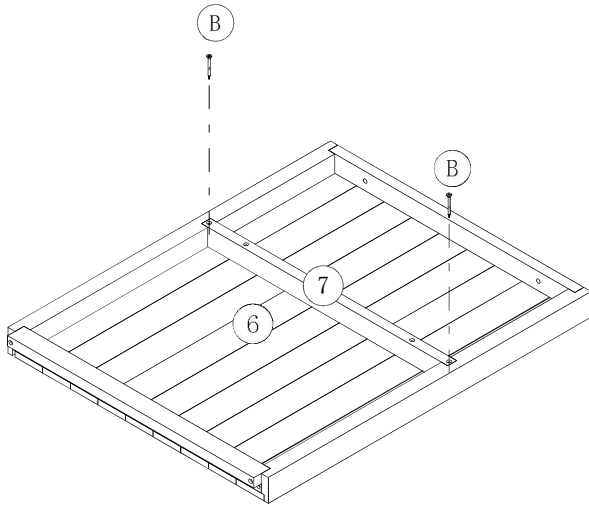

3

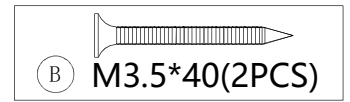
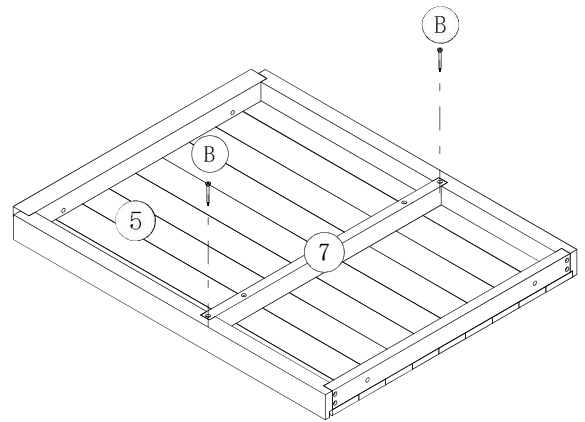

4

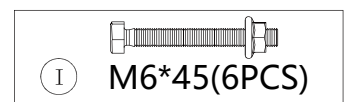
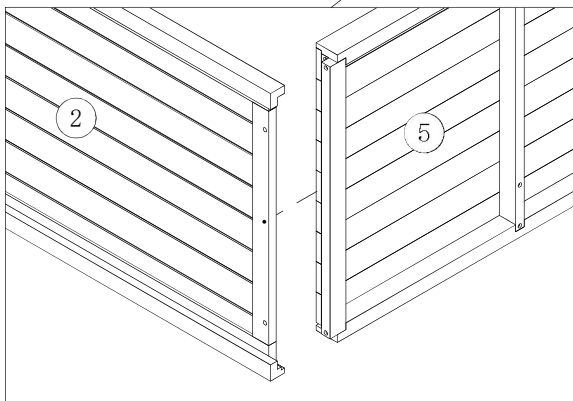
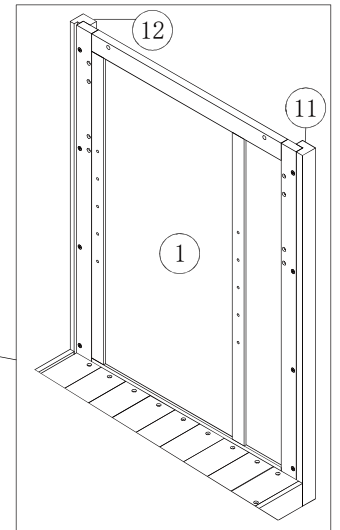
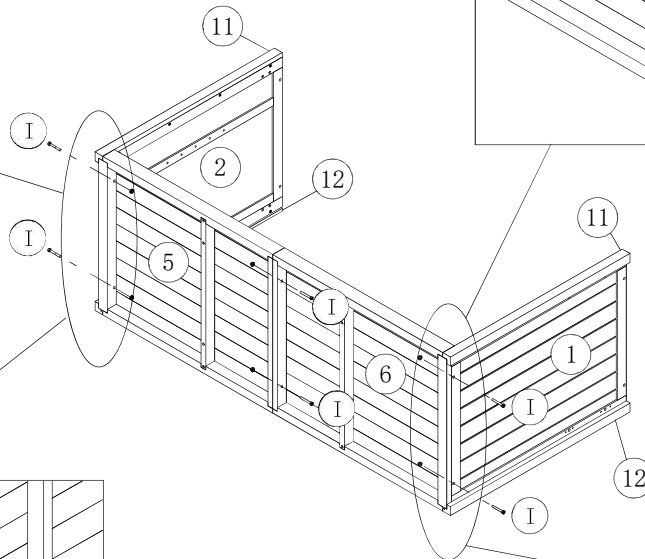
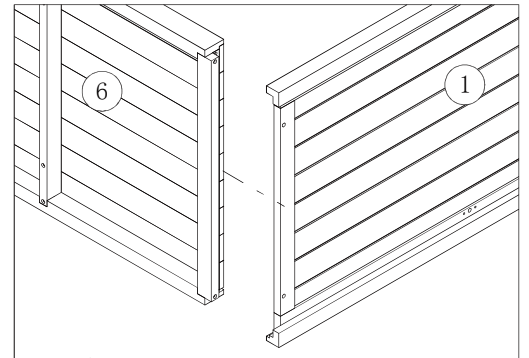
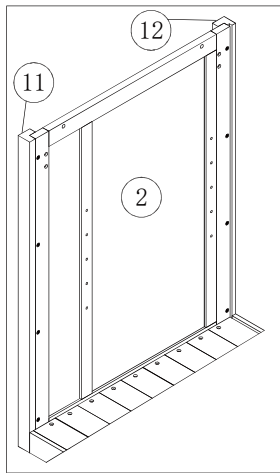

5

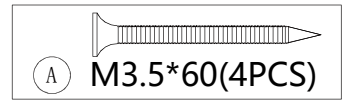
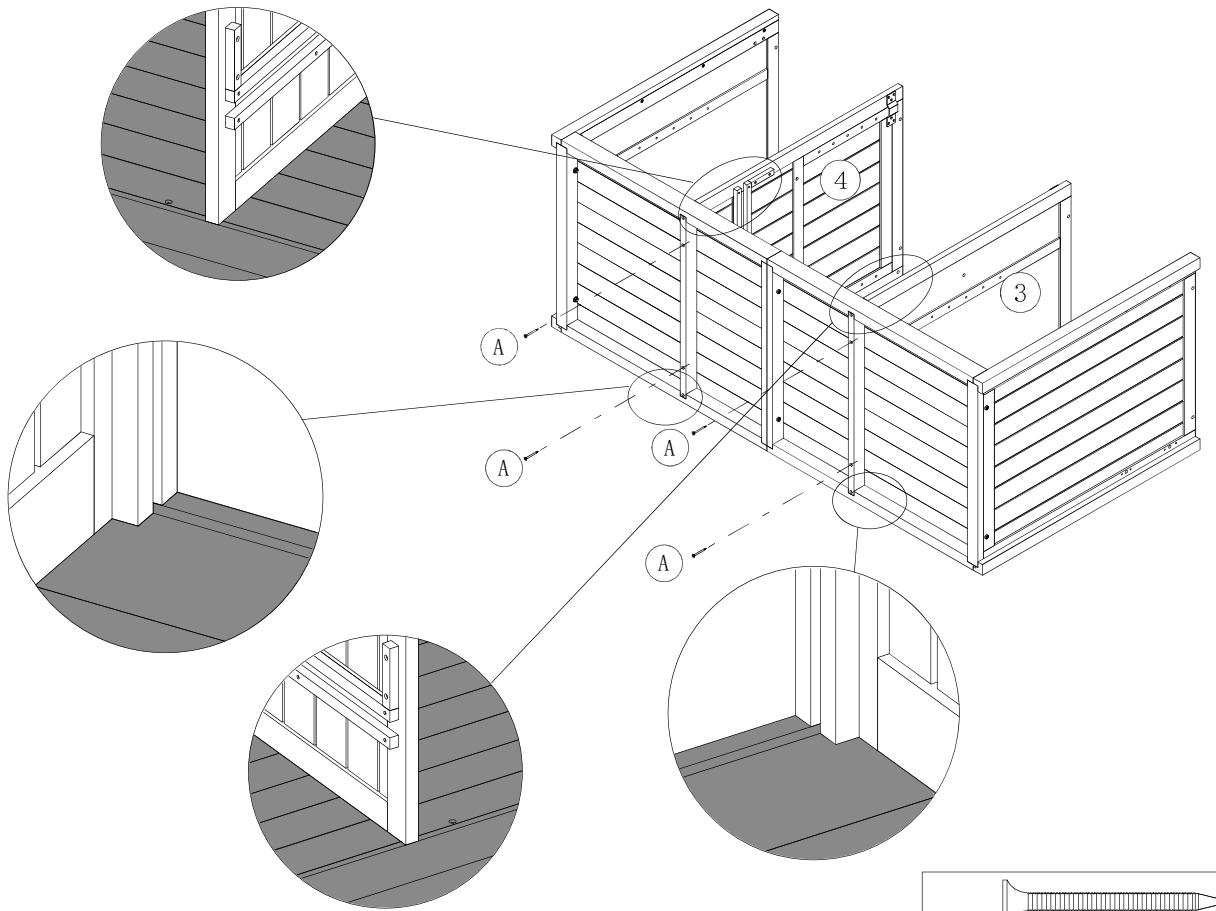

6

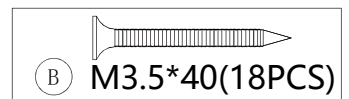
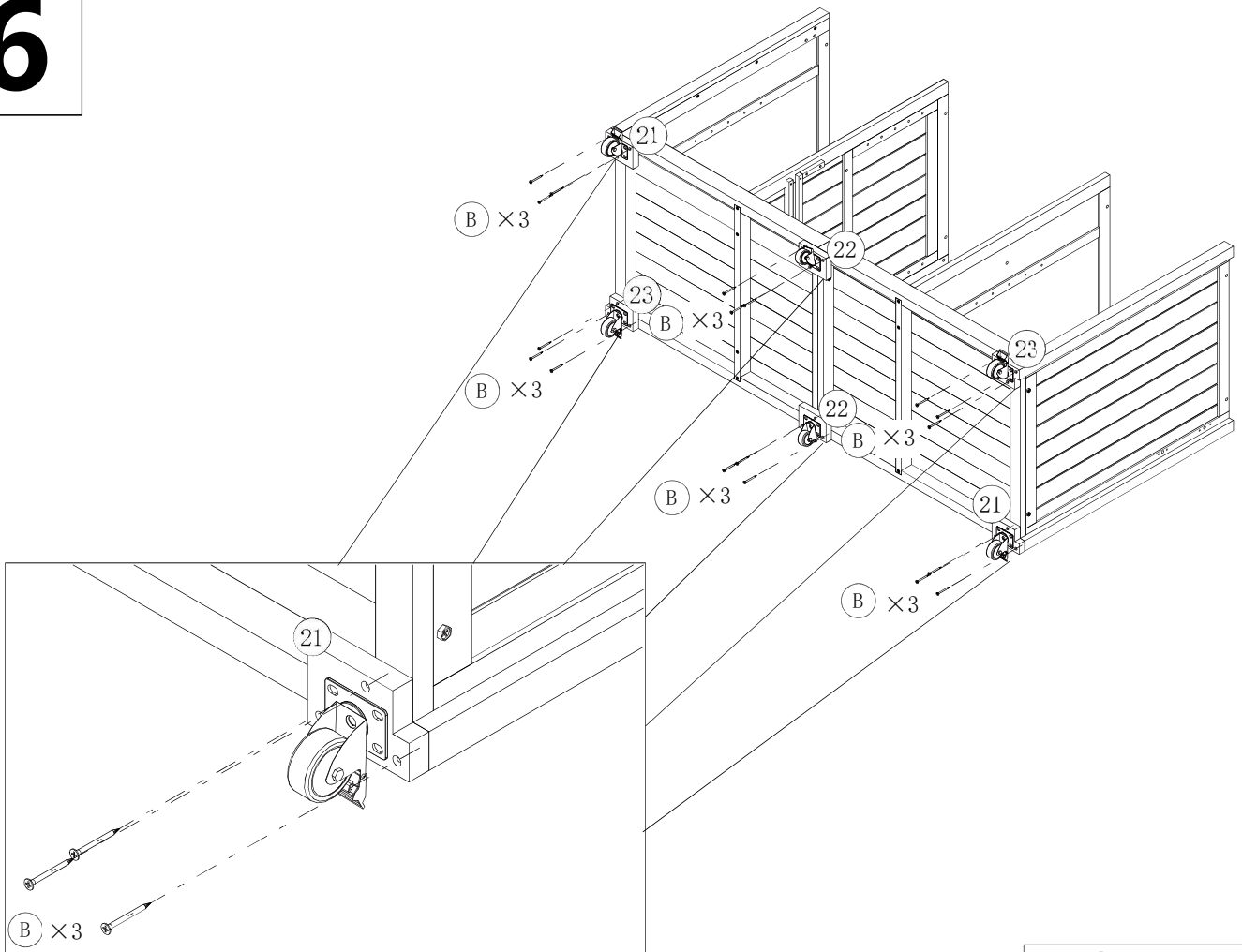

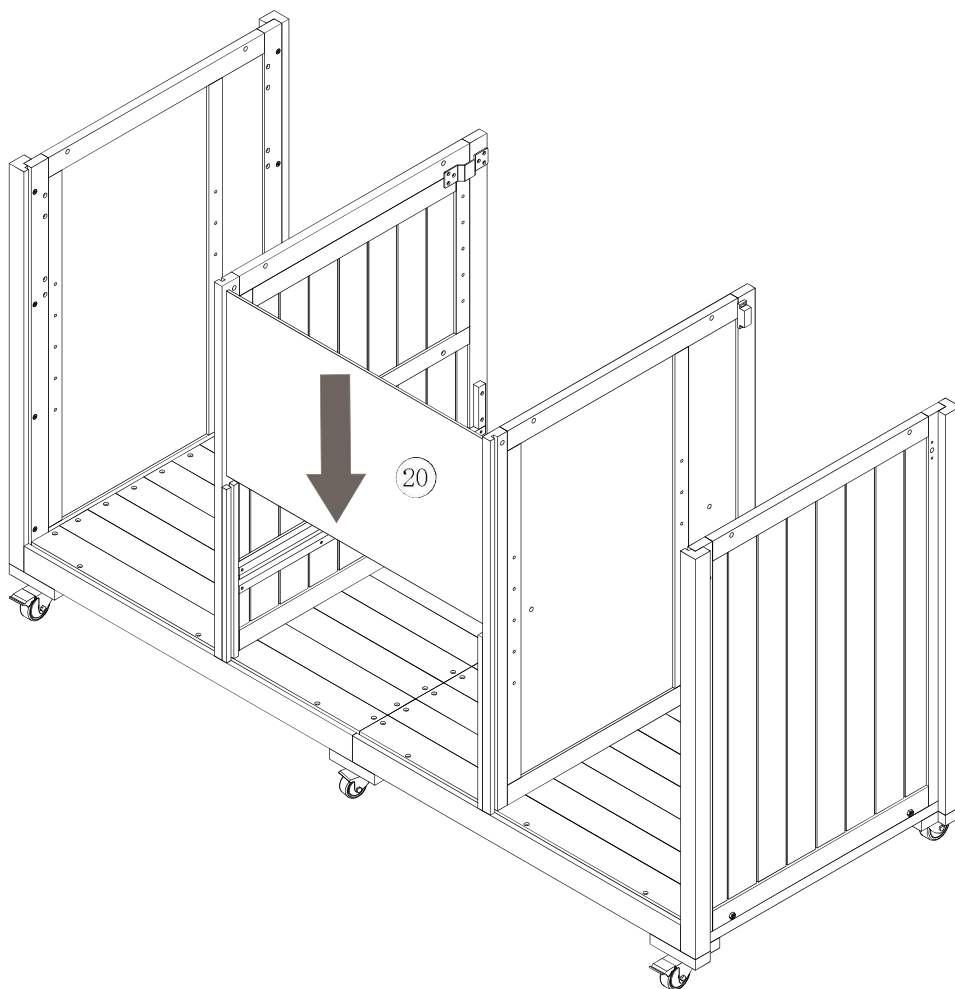

7

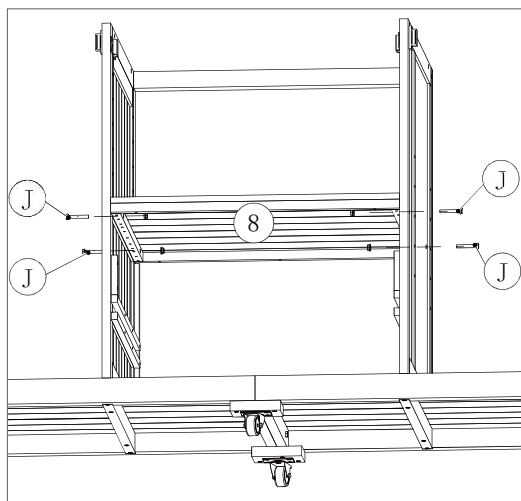
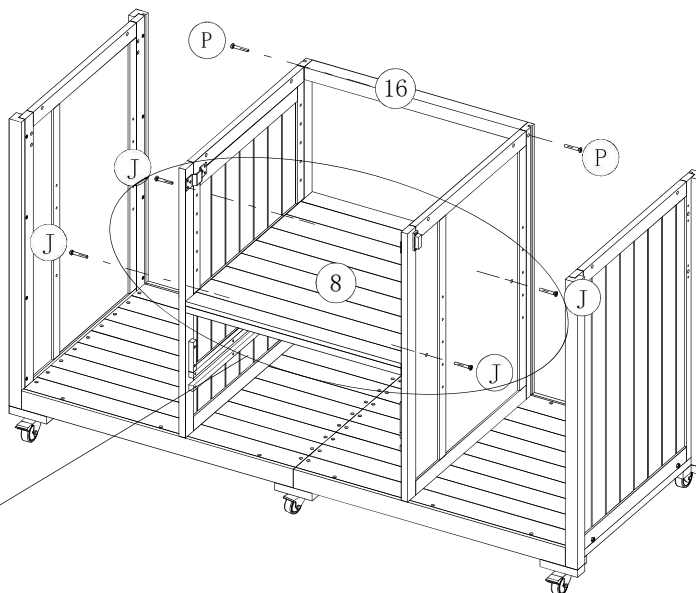

8

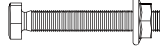

	M6*40(4PCS)
	M6*40(2PCS)

9

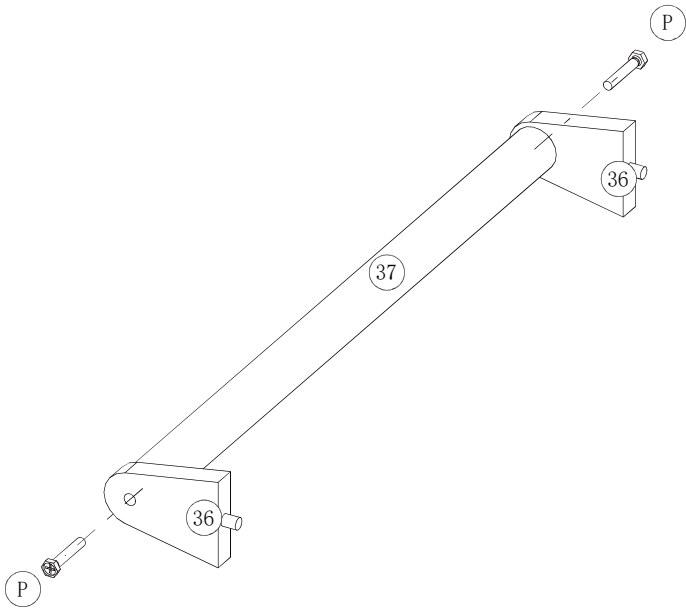

P M6*40(2PCS)

10

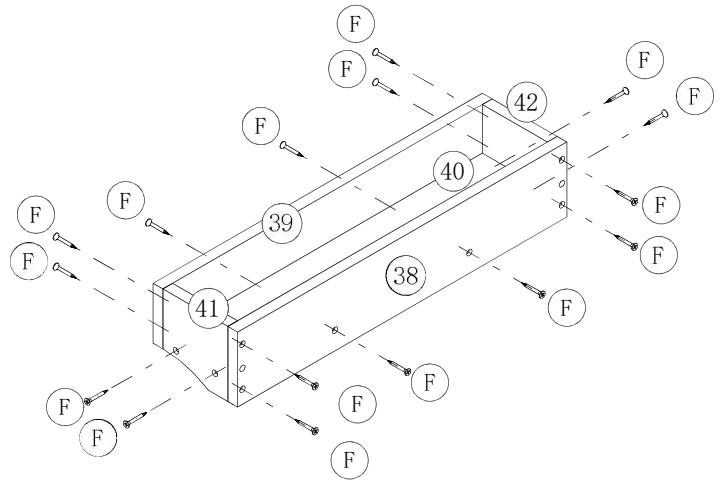

F M3.0*28(16PCS)

11

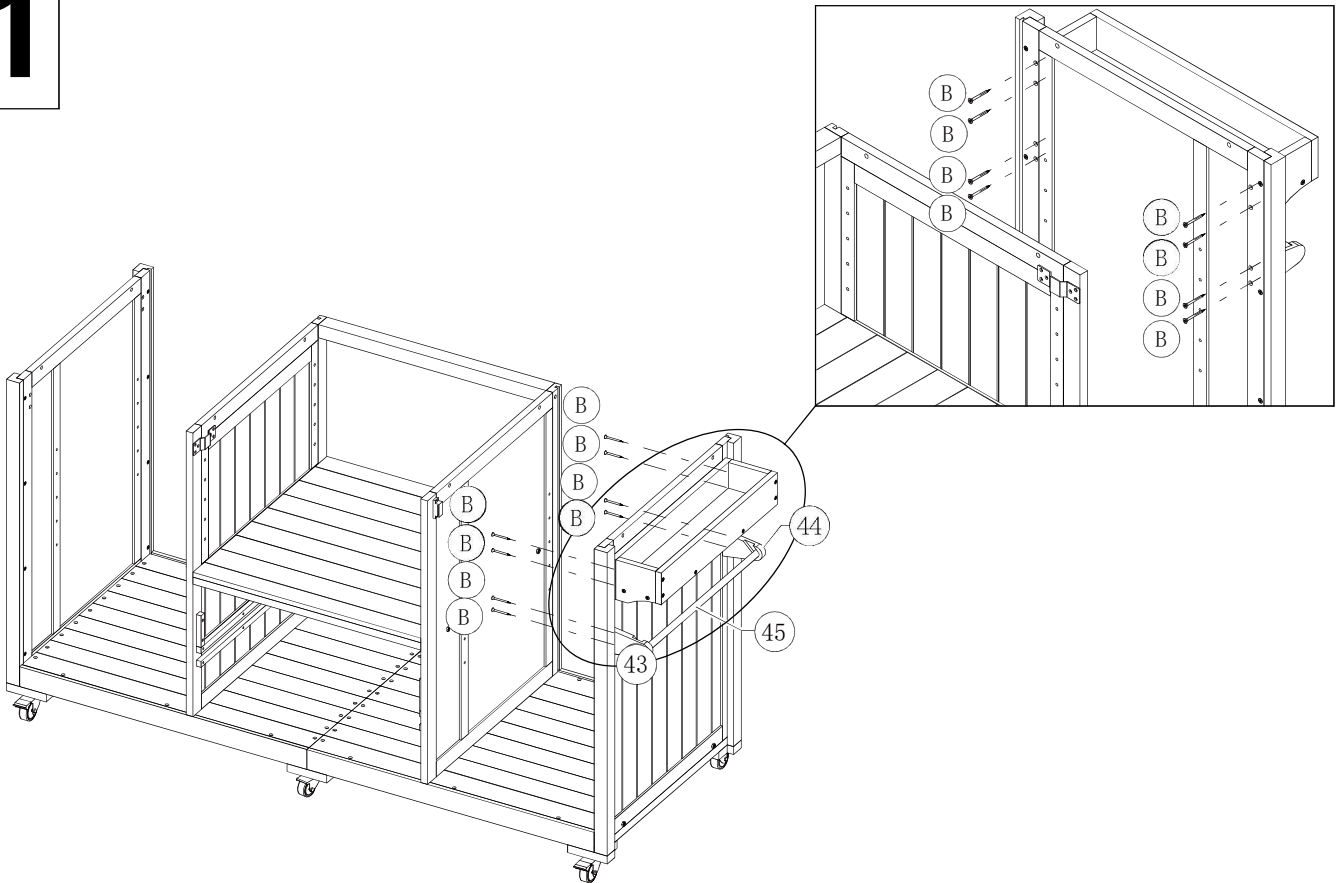

B M3.5*40(8PCS)

12

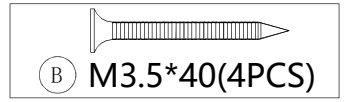
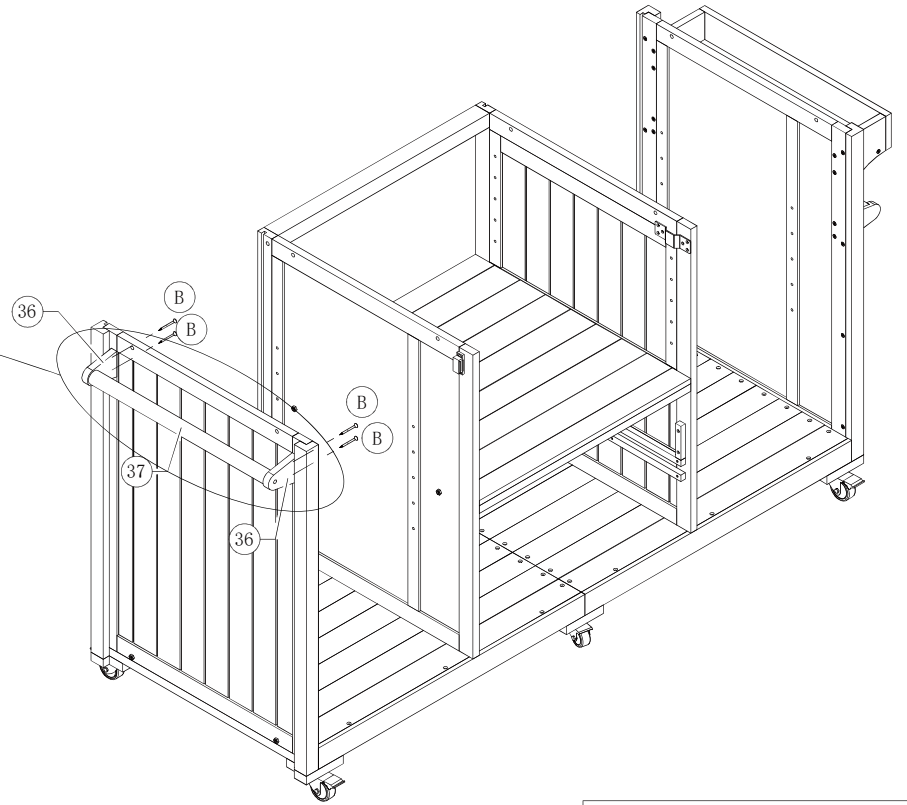
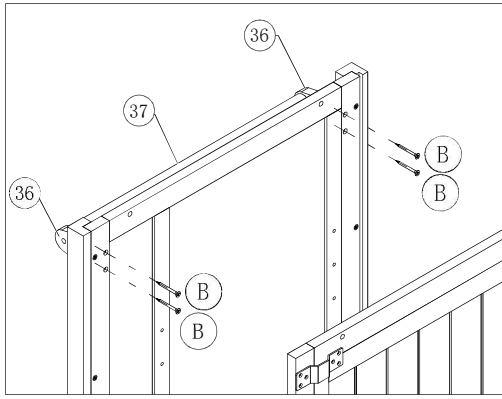

13

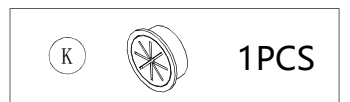
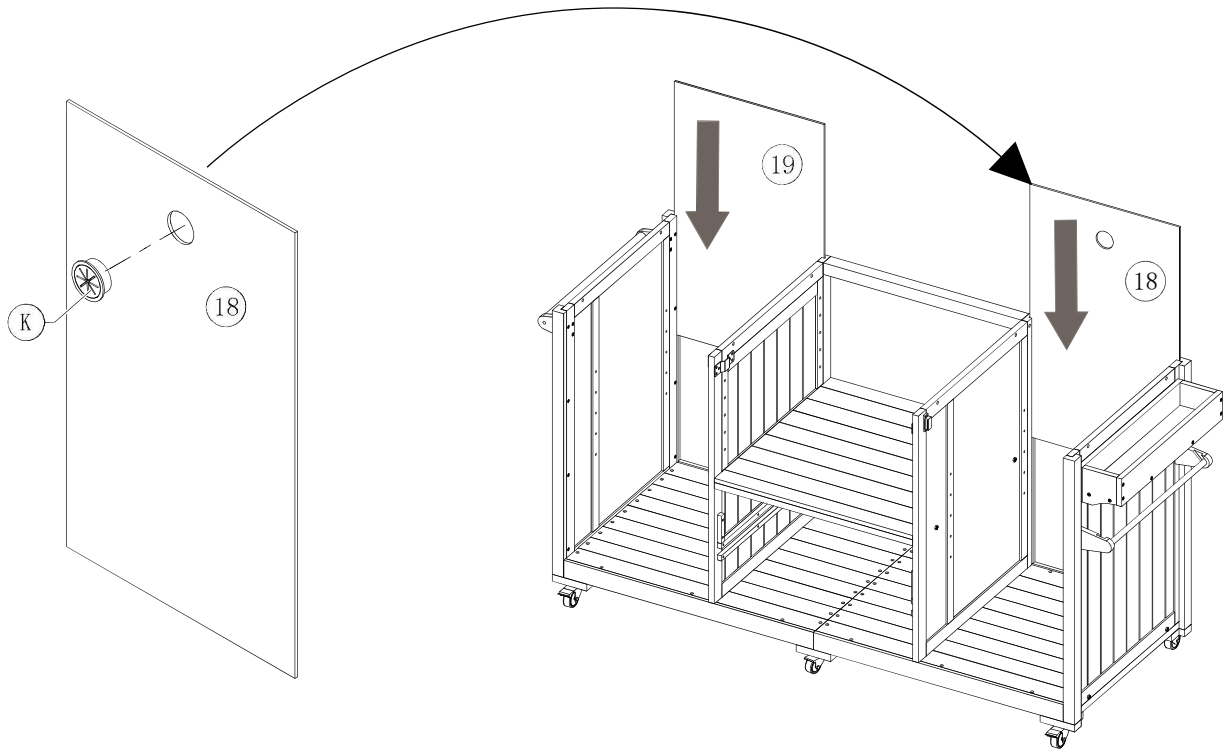

14

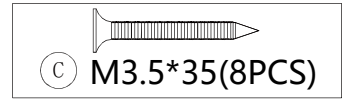
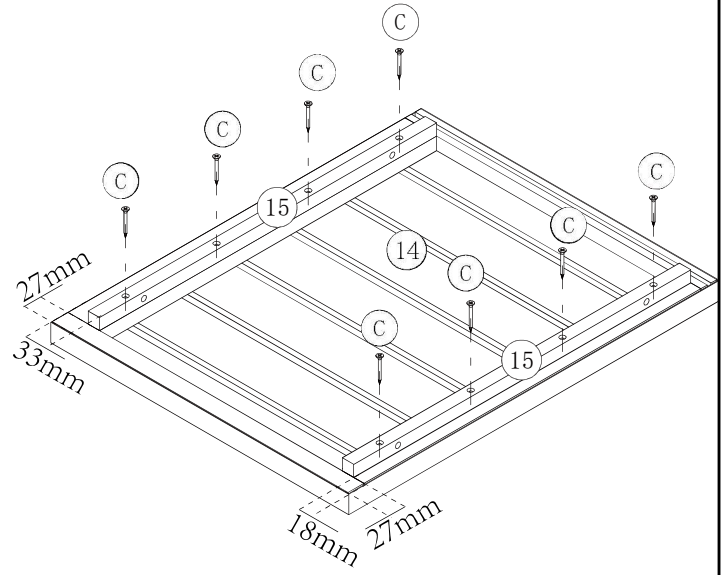
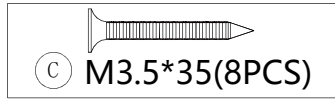
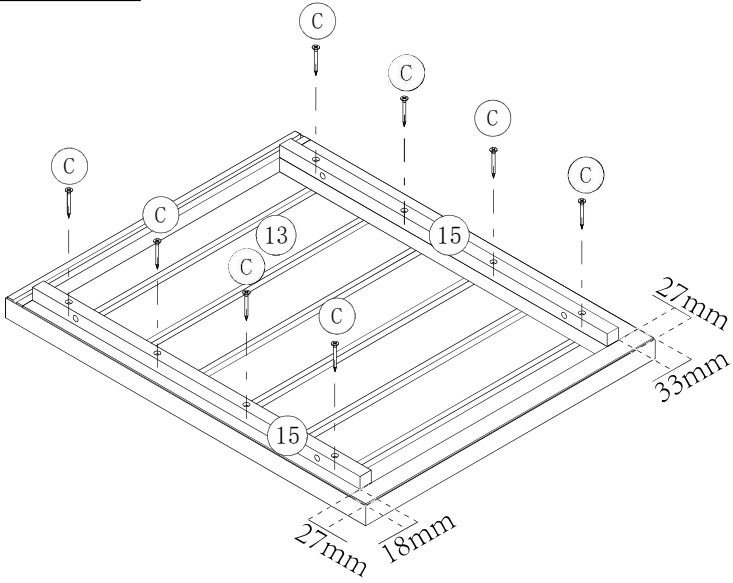

15

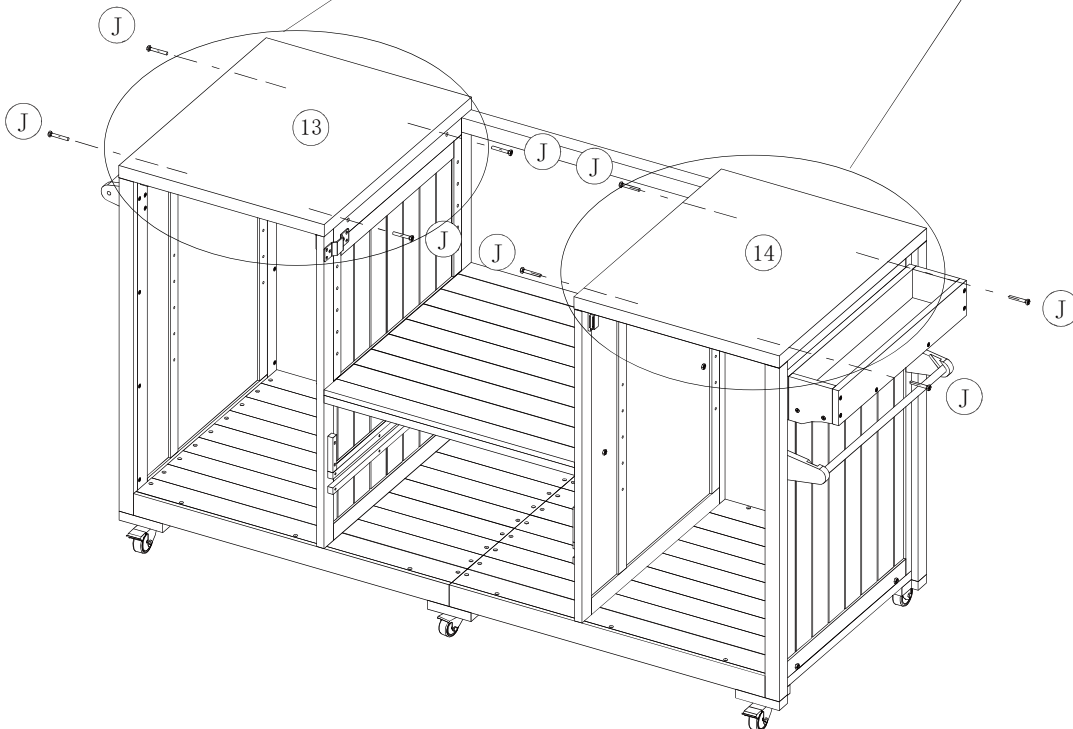
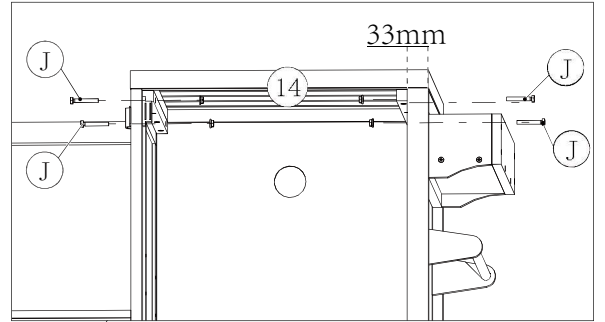
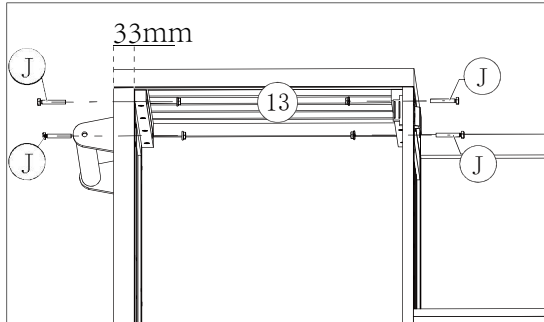

16

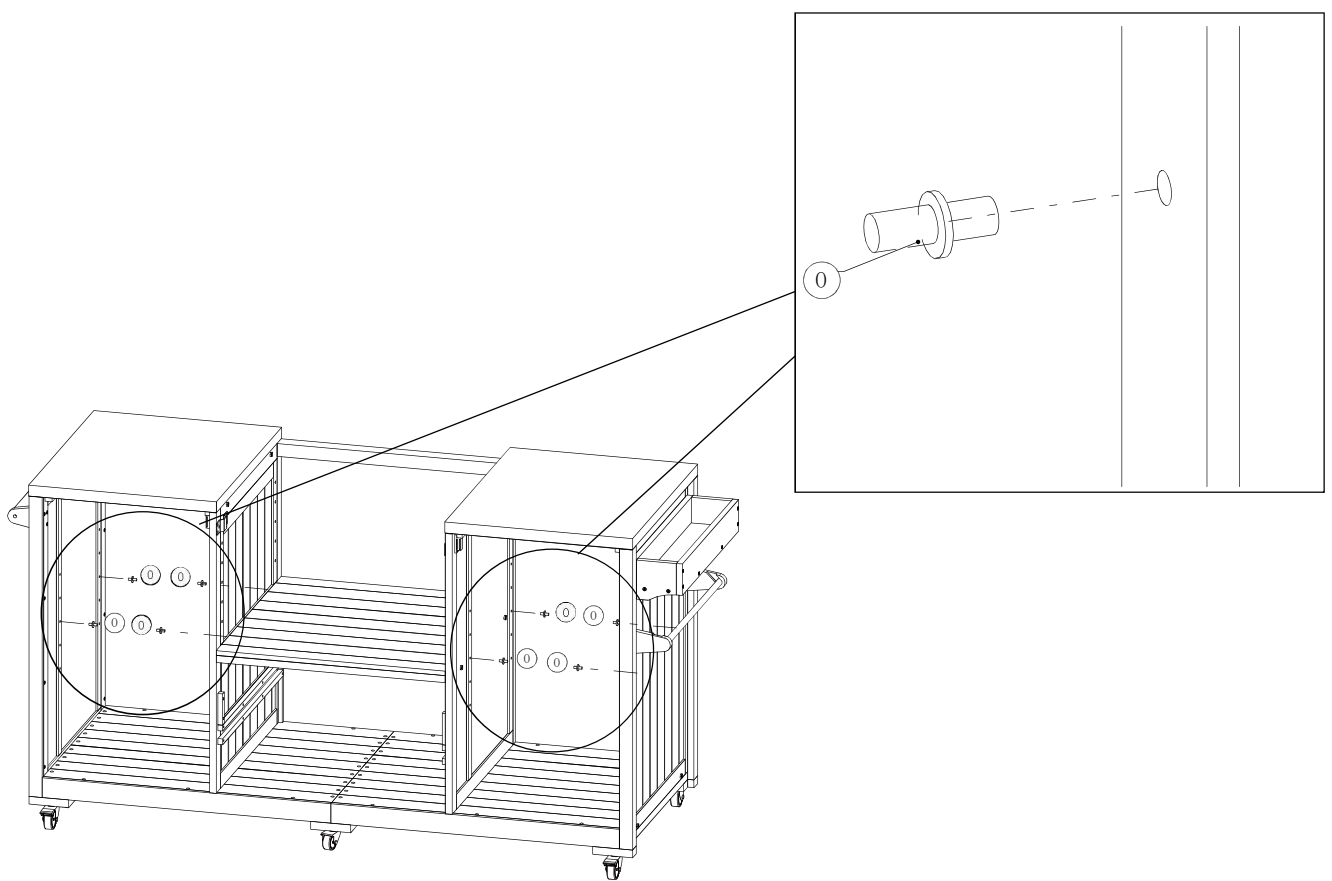

17

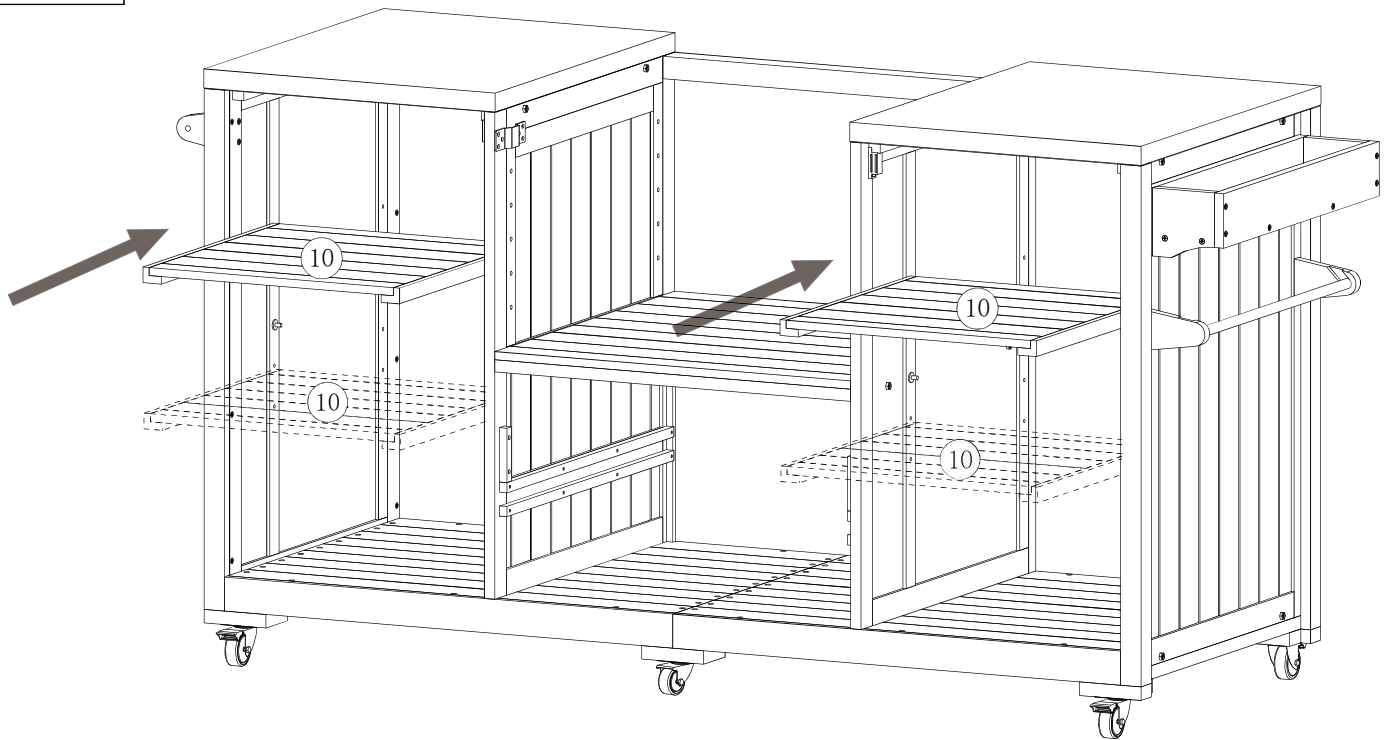

The two shelves ⑩ can be put into any left or right side as desired.
The height can be freely adjusted.

18

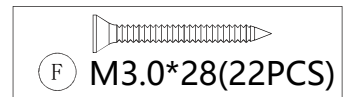
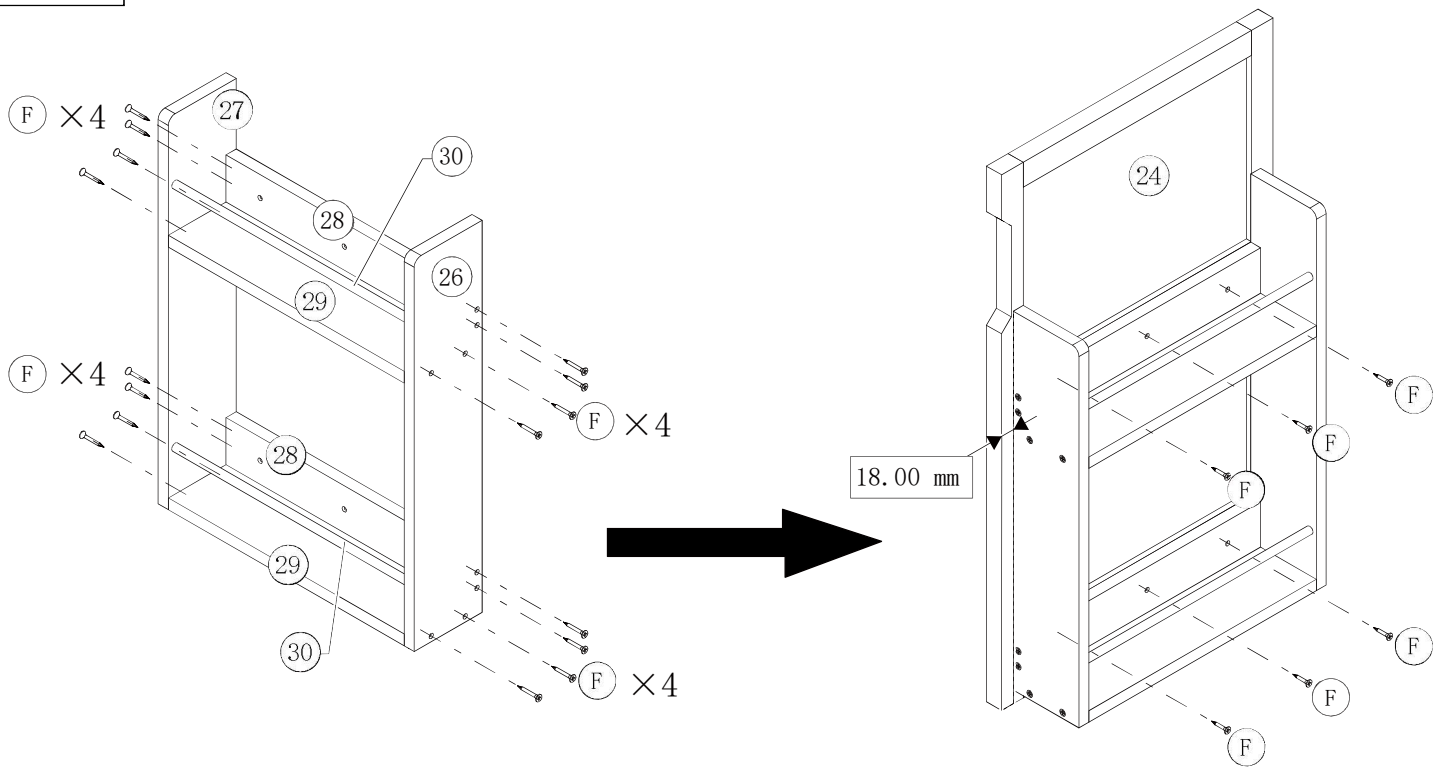

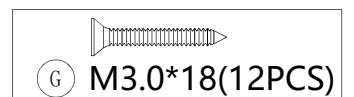
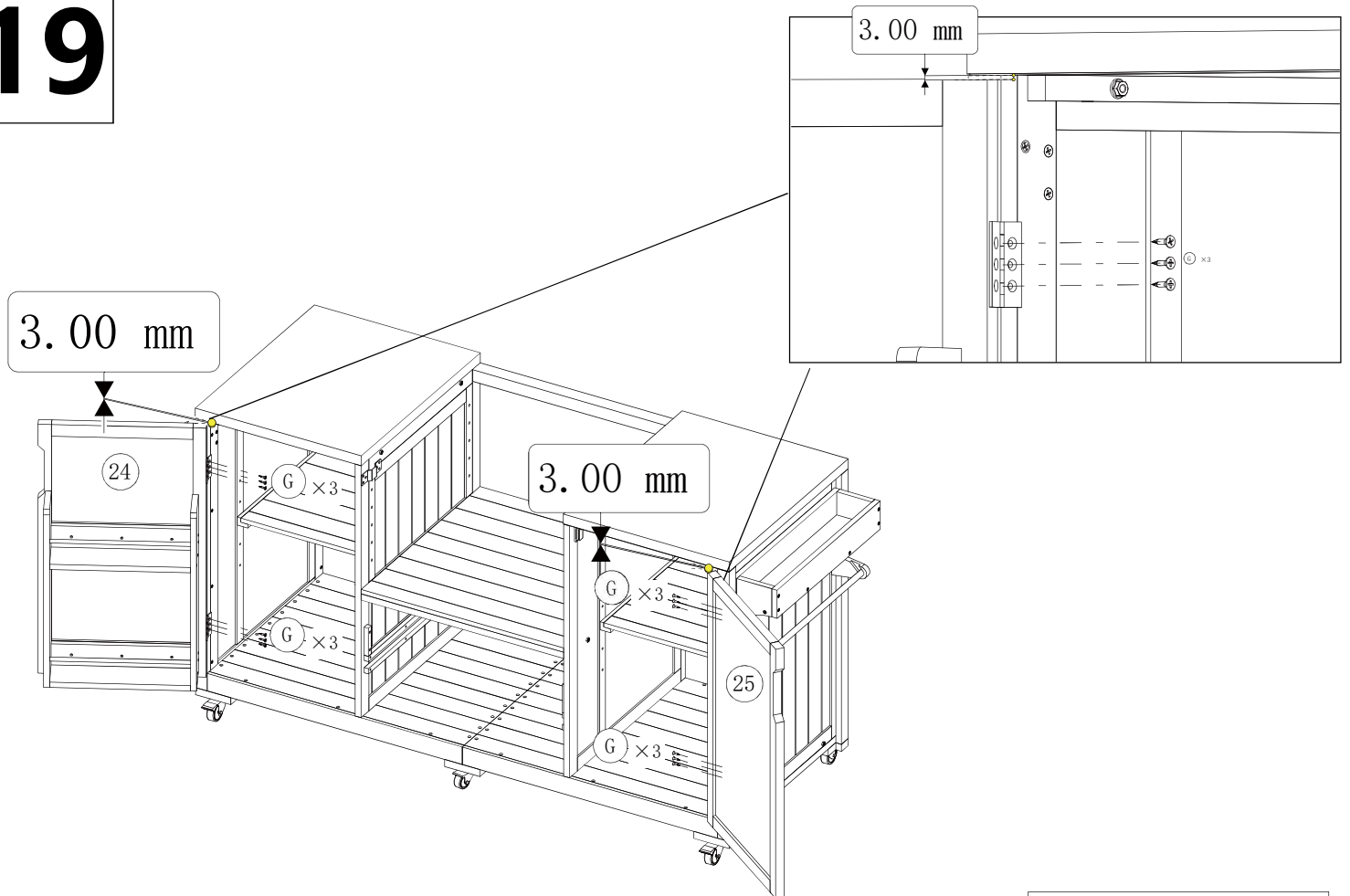

19



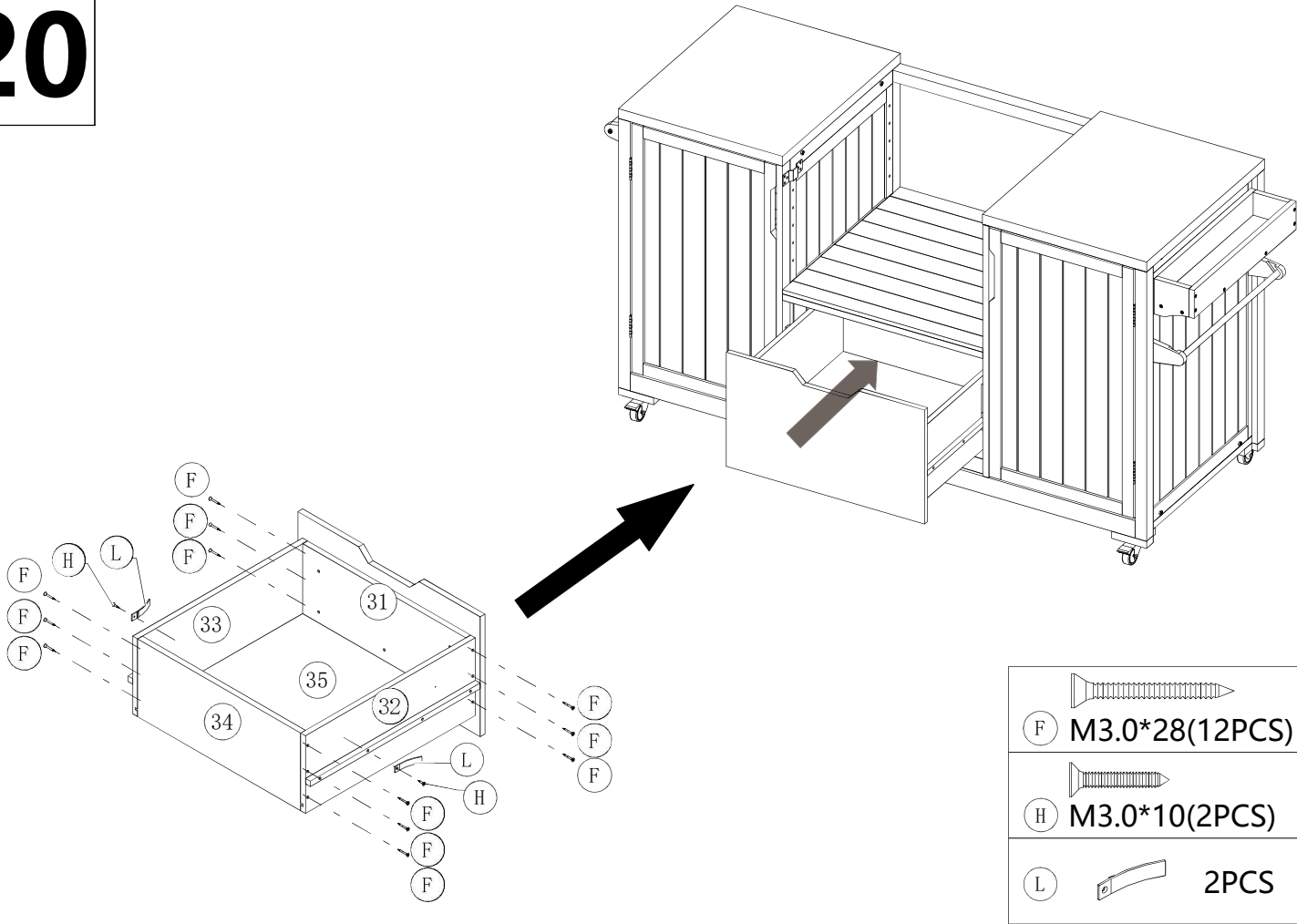

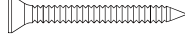
20

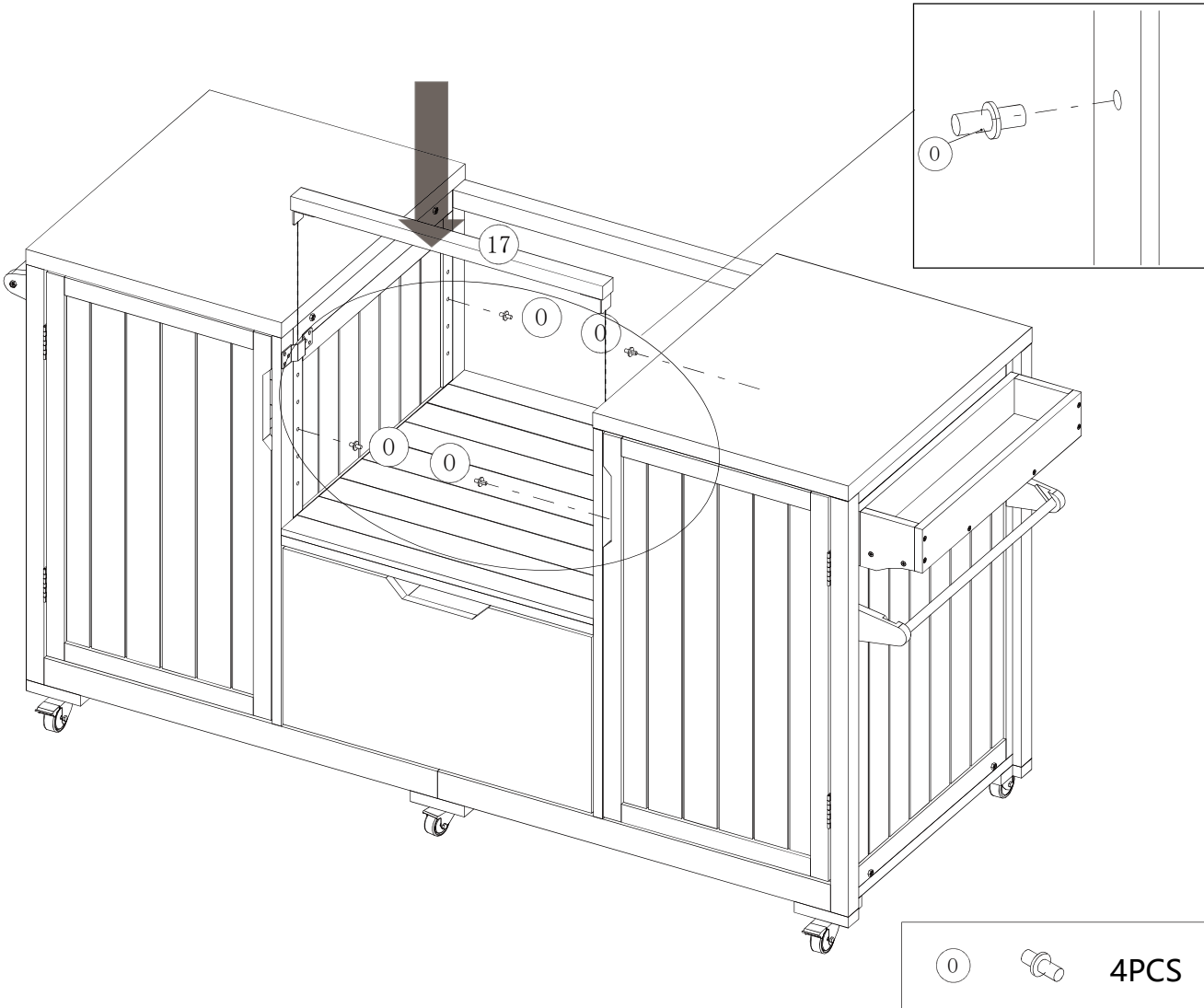

-  (F) M3.0*28(12PCS)
-  (H) M3.0*10(2PCS)
-  (L) 2PCS

21



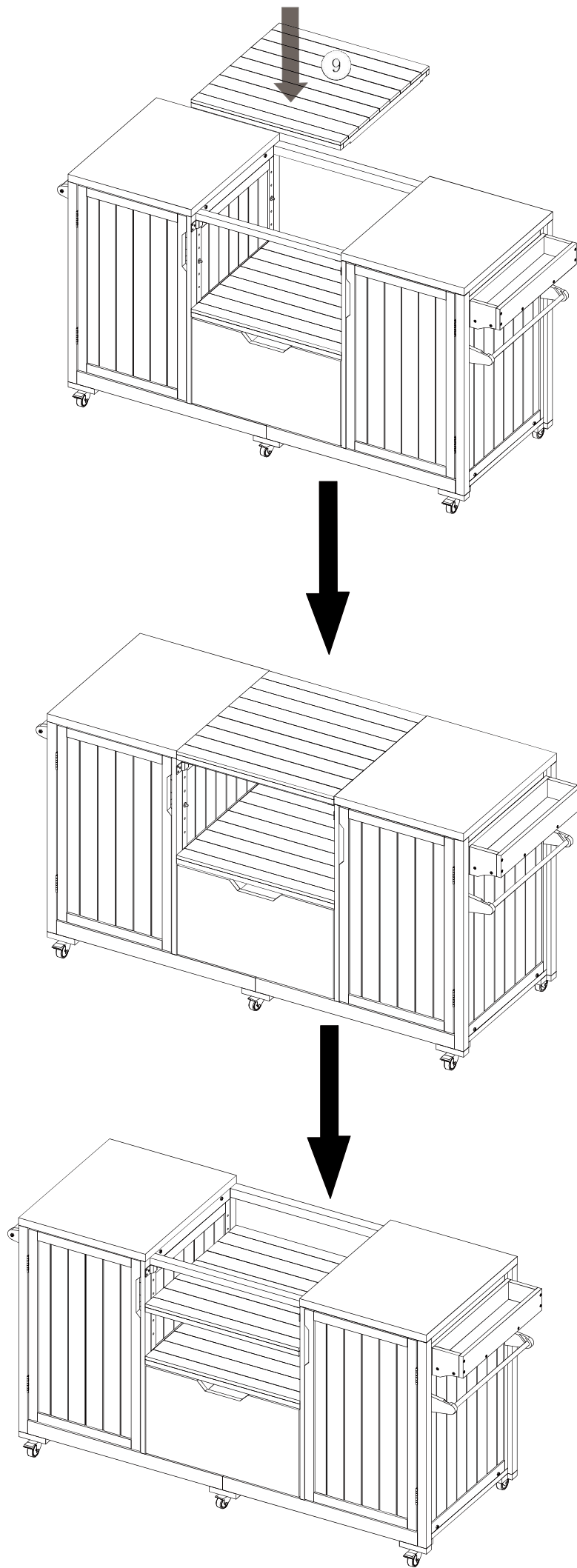

-  (0)  4PCS

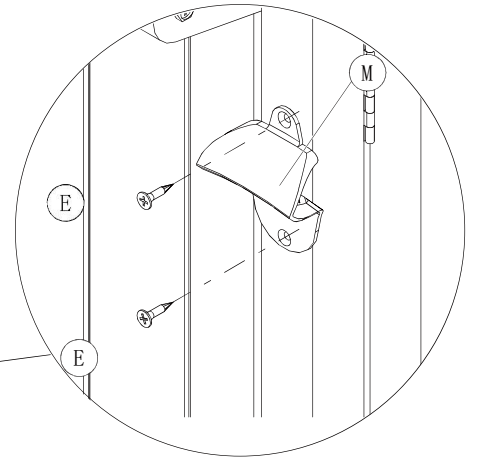
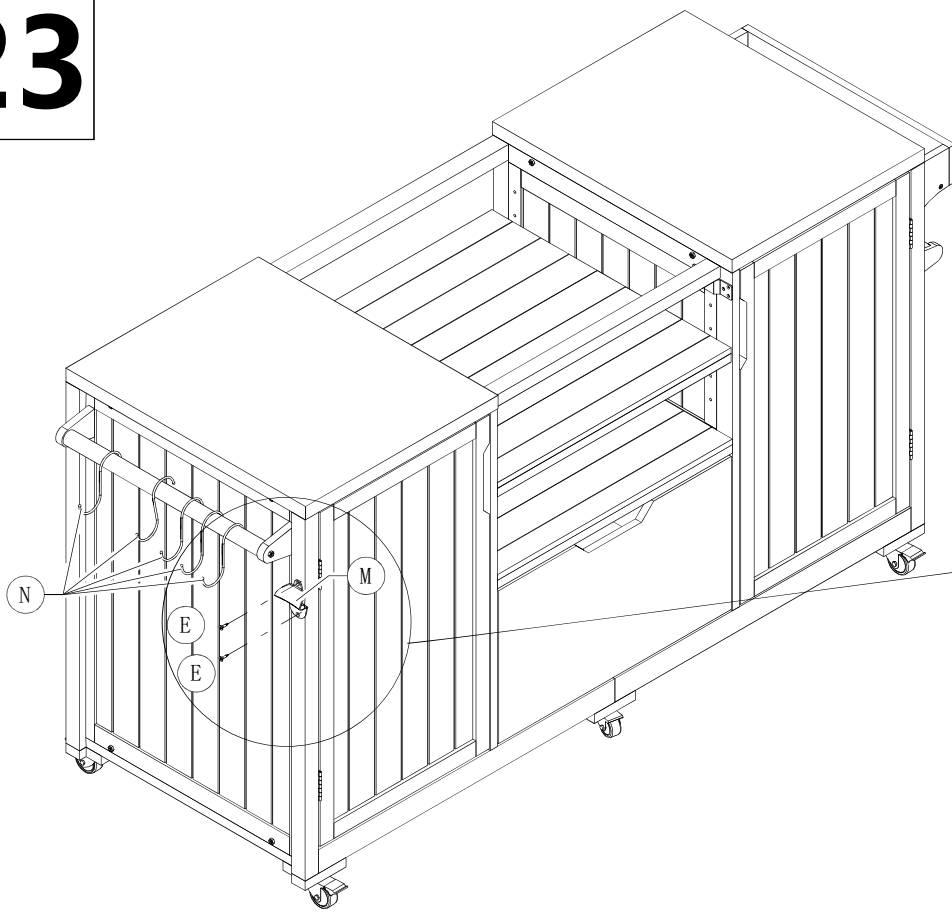

23



	M3.5*25(2PCS)
	1PCS
	5PCS

24

