

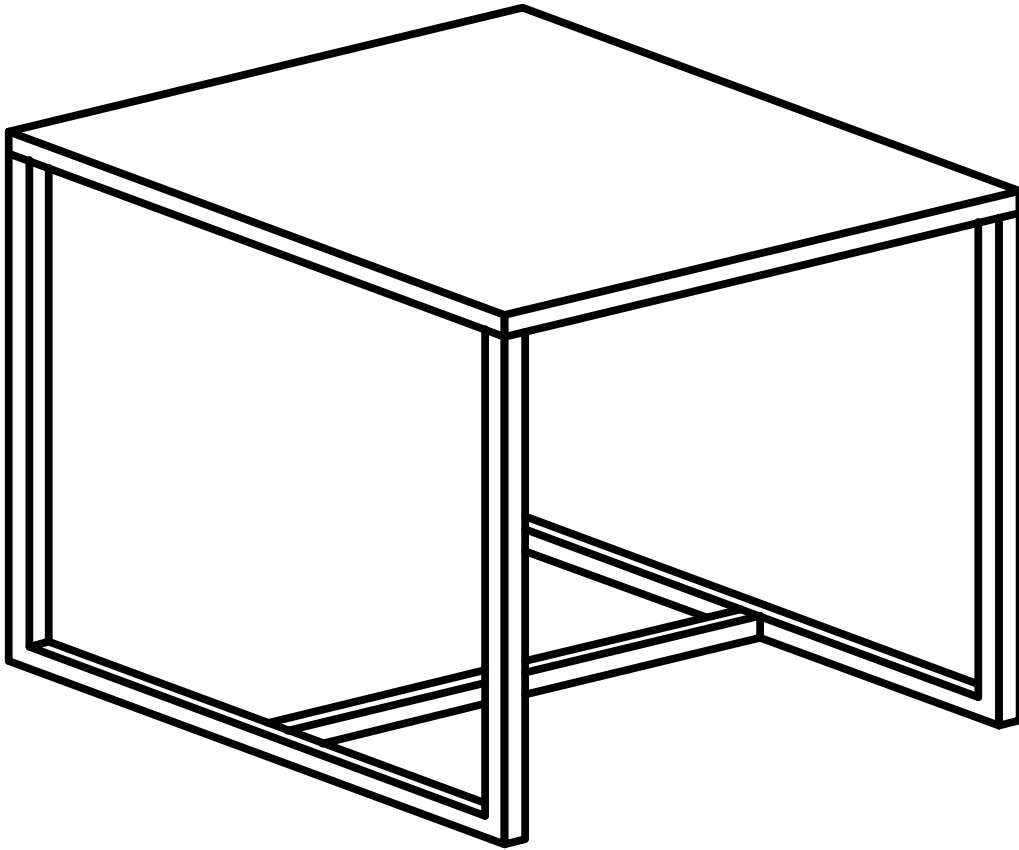



# Assembly Instructions



**\*Don't fully tighten all the bolts till the very end!**

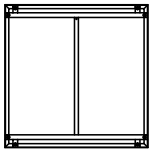

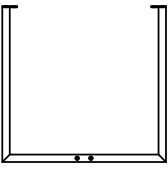
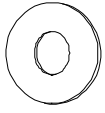
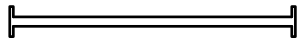
## PRE-ASSEMBLY PREPARATION:

- Please read through the instructions before beginning assembly.
- Clear out the space for assembly and lay out all of the parts based on the Parts List, extra room will allow you to easily determine if all the pieces are present.
- Keep small parts and pieces away from children until fully assembled.

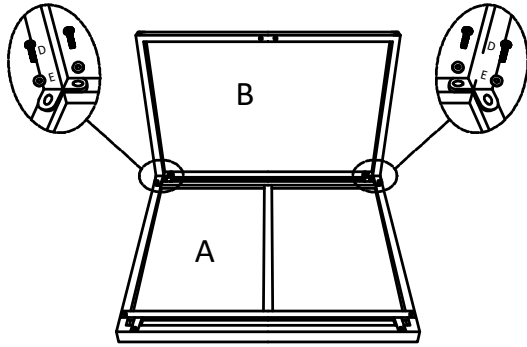

Part no.	Part	QTY	Image	Part no.	Part	QTY	Image
A	Table top	1		D	Bolt (M6*20mm)	12	
B	Table leg	2		E	Washer Ø16*Ø6.5*1mm	12	
C	Connecting tube	1		F	Allen Wrench	1	

**Step 1:** Attach legs B to table top A with 8pcs bolts D and 8pcs washers E, attach connecting tube C to legs B with 4pcs bolts D and 4pcs washers E, using Allen wrench F. Assembly is now complete and the product is ready for use.



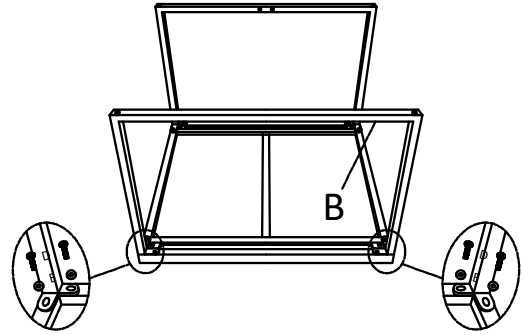

D		M6*20	4
E		Ø16*Ø6.5*1	4

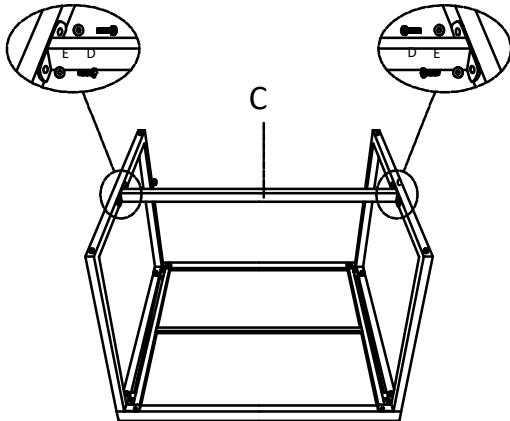

D		M6*20	4
E		Ø16*Ø6.5*1	4



D		M6*20	4
E		Ø16*Ø6.5*1	4

