

MONACO BED SIZE FULL

ASSEMBLY INSTRUCTIONS

SKU 4006LT Distressed Waxed Pine



**MAX BED
WEIGHT**

IMPORTANT PLEASE READ BEFORE YOU CONTINUE FURTHER FOR DOMESTIC USE ONLY CARE AND MAINTENANCE

- After unpacking this product, please keep the original packaging in case it needs to be returned for any reason.
- Please ensure all fittings and parts are present before commencing with assembly.
- We recommend that you lay a blanket or sheet on the floor to avoid damage to both your floor and the product.
- We strongly recommend that you keep children away from your work area.
- Assemble this product as close to its final position as possible.
- Never drag or push products as this could cause damage to the joints making it inferior.
- Do not drag or push items across your furniture as this may cause the surface to scratch.
- Do not place this product next to radiator or in direct sunlight.
- Wood is a natural product and may expand if subjected to damp and may shrink or crack if subjected to heat. Therefore, it is recommended that room temperature is maintained, with no sudden temperature fluctuations.
- Make sure any spillage is wiped off immediately.
- Do not place hot or chilled items directly on to the surface, use a place mat or marking will occur.
- For general cleaning, use a soft cotton or micro fibre cloth and do not use detergents of any kind.
- Do not place on a wet or damp floor as staining may occur to your floor.
- From time to time, it may be necessary to tighten fittings; regular inspections should be carried out.

how to contact us:

More details how to assemble your product at: seconique-us.com then follows:



info@seconiqueus.com



seconique-us.com

SKU 4006LT Distressed Waxed Pine



seconique-us.com



seconique-us.com



seconique US



[@seconiqueus](https://www.instagram.com/seconiqueus)

BEFORE START **READ QR CODE TO FIND MORE INFORMATION**
HOW TO ASSEMBLY THIS PRODUCT:

SKU 4006LT Distressed Waxed Pine

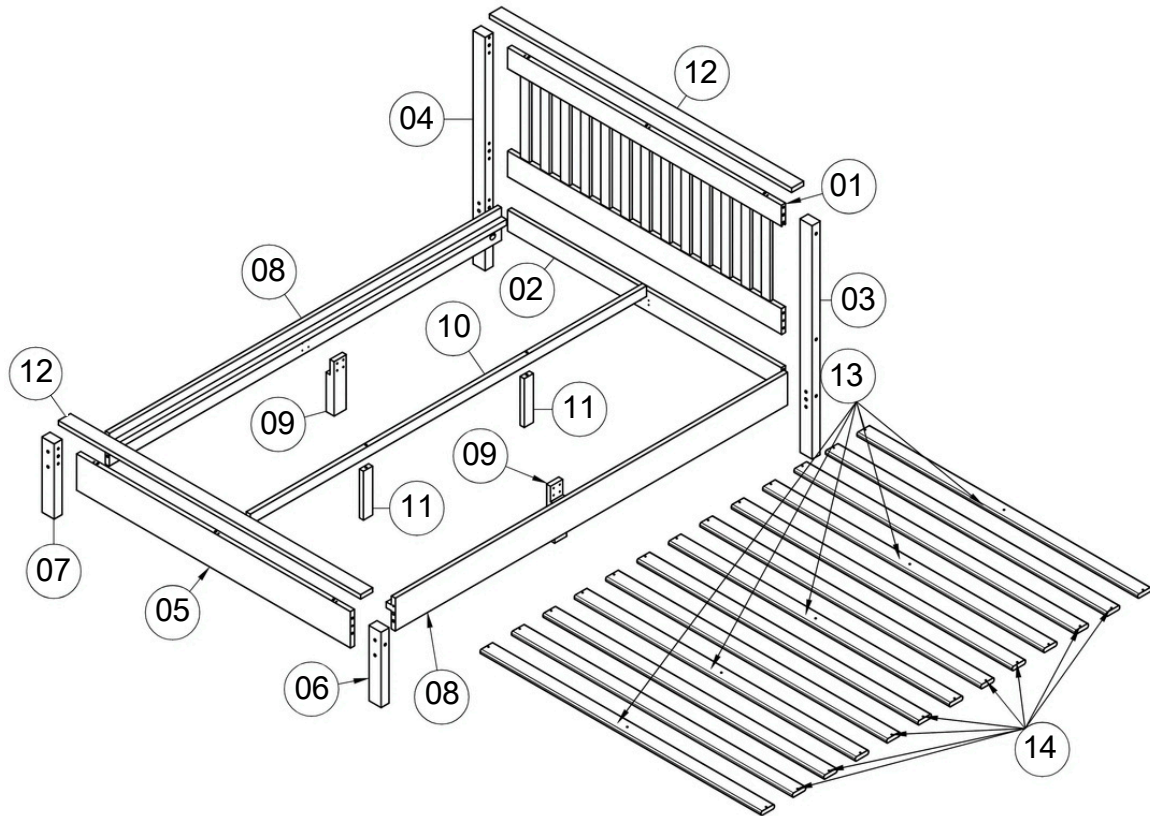











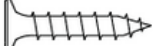

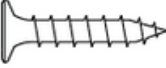
Please Note: The parts below have been stamped with the part number to help identify them during assembly

| Part Number | Part Description | Quantity | Carton |
|-------------|----------------------|----------|--------|
| 01 | Headboard Panel | 1 | 2/2 |
| 02 | Headboard Crossbeam | 1 | 2/2 |
| 03 | Right Headboard Post | 1 | 1/2 |
| 04 | Left Headboard Post | 1 | 1/2 |
| 05 | Footboard Panel | 1 | 2/2 |
| 06 | Right Footboard Post | 1 | 1/2 |
| 07 | Left Footboard Post | 1 | 1/2 |
| 08 | Siderail | 2 | 1/2 |
| 09 | Siderail Support | 2 | 1/2 |
| 10 | Centre Rail | 1 | 1/2 |
| 11 | Centre Support Leg | 2 | 1/2 |
| 12 | Top Crossbeam | 2 | 1/2 |
| 13 | Slats (3 Holes) | 5 | 2/2 |
| 14 | Slats (2 Holes) | 8 | 2/2 |

BEFORE START **READ** QR CODE TO FIND MORE INFORMATION
HOW TO ASSEMBLY THIS PRODUCT:

SKU 4006LT Distressed Waxed Pine

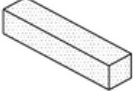

| | | | | | | | |
|----------|----------------------|---|-----------|----------|----|---|-----------|
| A | +1 |  10 x 50 mm | 04 | I | +1 |  3.5 x 30 mm | 31 |
| B | +1 |  8 x 40 mm | 22 | J | +1 |  4.0 x 35 mm | 06 |
| C | +1 |  | 04 | K | +1 |  4.0 x 35 mm | 08 |
| D | |  1/4" x 90 mm (Black) | 04 | L | +1 |  4.0 x 16mm | 10 |
| E | |  7 x 100 mm (Black) | 08 | M | |  | 02 |
| F | |  | 01 | N | |  7 x 80mm (Yellow) | 02 |
| G | (SPACER) (WOODEN) |  | 02 | O | |  7 x 80mm (Black) | 04 |
| H | |  GLUE | 01 | | | | |

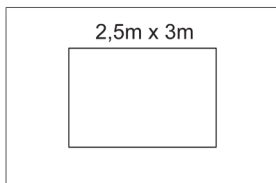
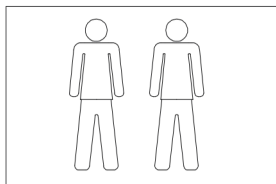
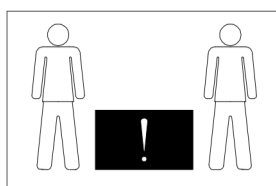

TOOLS REQUIRED

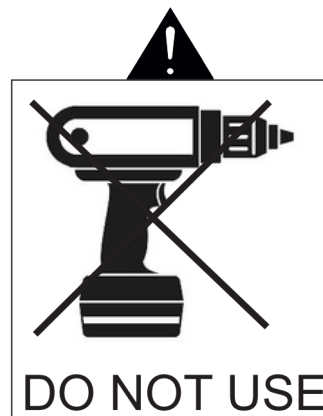
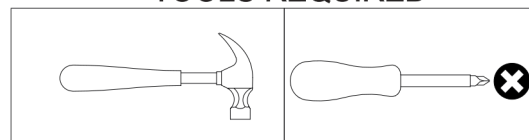

* Use of power tools to assemble this product will invalidate any claim and damage this product making it unsafe !!!
* Please assemble on a clean soft surface to avoid damage.

* Please check contents and read the instructions before commencing assembly.
* Assemble this product following the enclosed instructions carefully.
* Please take care to avoid damaging panels during assembly.



STEP 1

TOOLS REQUIRED:

PARTS REQUIRED:

| | | | | | |
|----|---------------------|----|----|-----------|----|
| 01 | Headboard Panel | x1 | 05 | Footboard | x1 |
| 02 | Headboard Crossbeam | x1 | | | |

HARDWARE REQUIRED:

| | | |
|---|---|-----|
| B |  8 X 40 mm | x22 |
| H |  GLUE | x1 |

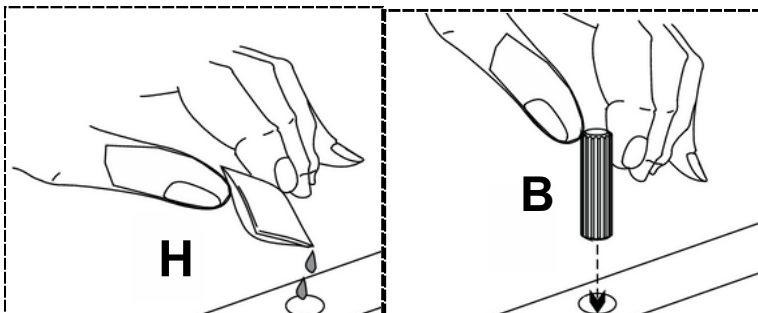
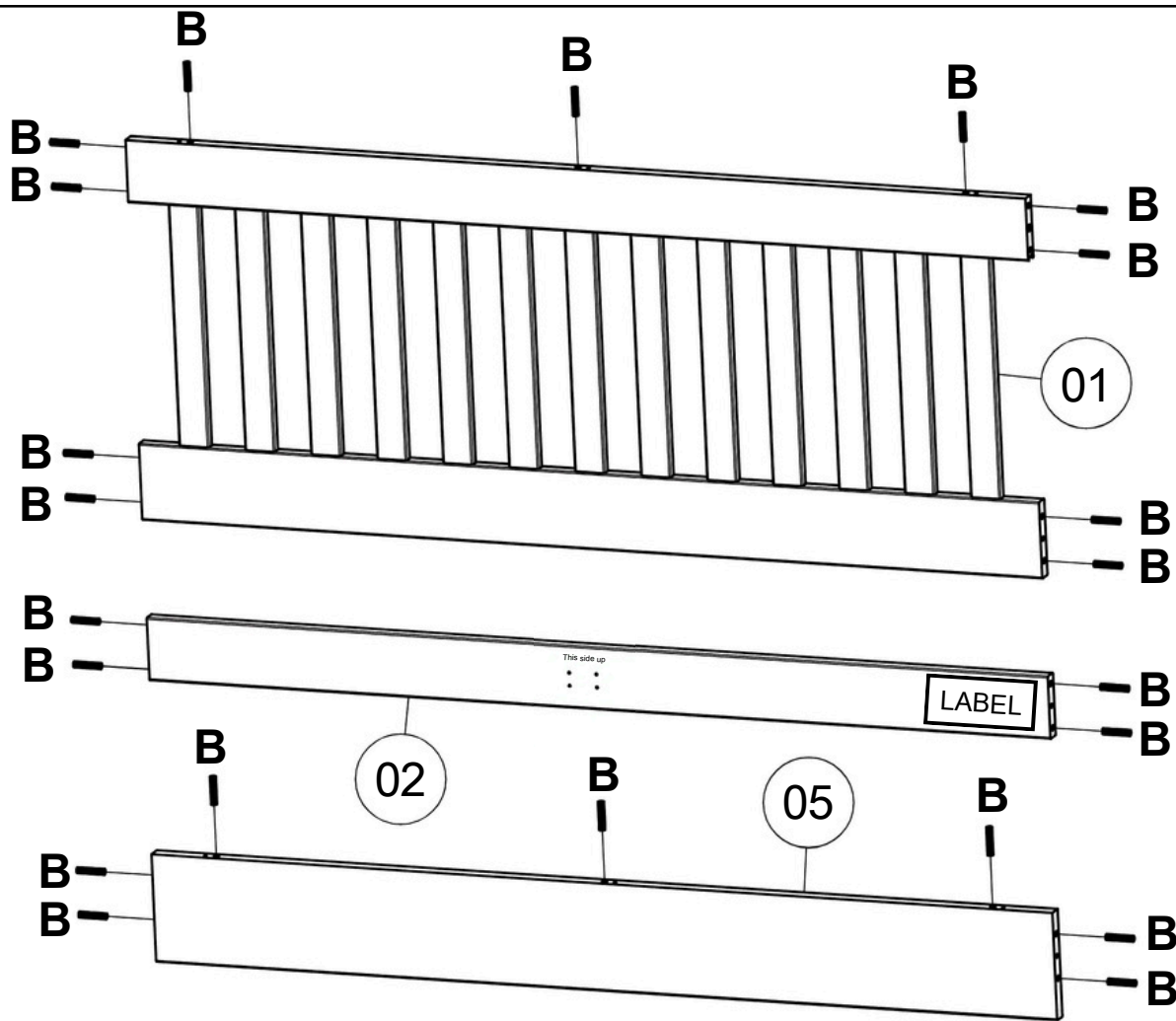

Glue must be added to the dowel holes on parts 01, 02 and 05.

STEP 2

TOOLS REQUIRED:

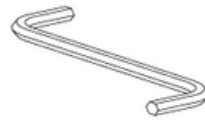

PARTS REQUIRED:

| | | | | | |
|----|---------------------|----|----|----------------------|----|
| 01 | Headboard Panel | x1 | 03 | Right Headboard Post | x1 |
| 02 | Headboard Crossbeam | x1 | 04 | Left Headboard Post | x1 |

HARDWARE REQUIRED:

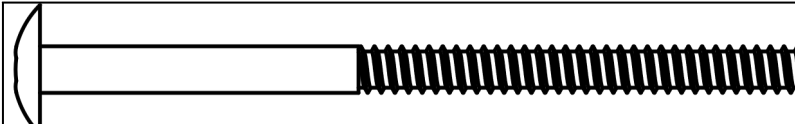
| | | | |
|---|---|--------------------|----|
| E |  | 7 X 100 mm (Black) | x6 |
|---|---|--------------------|----|

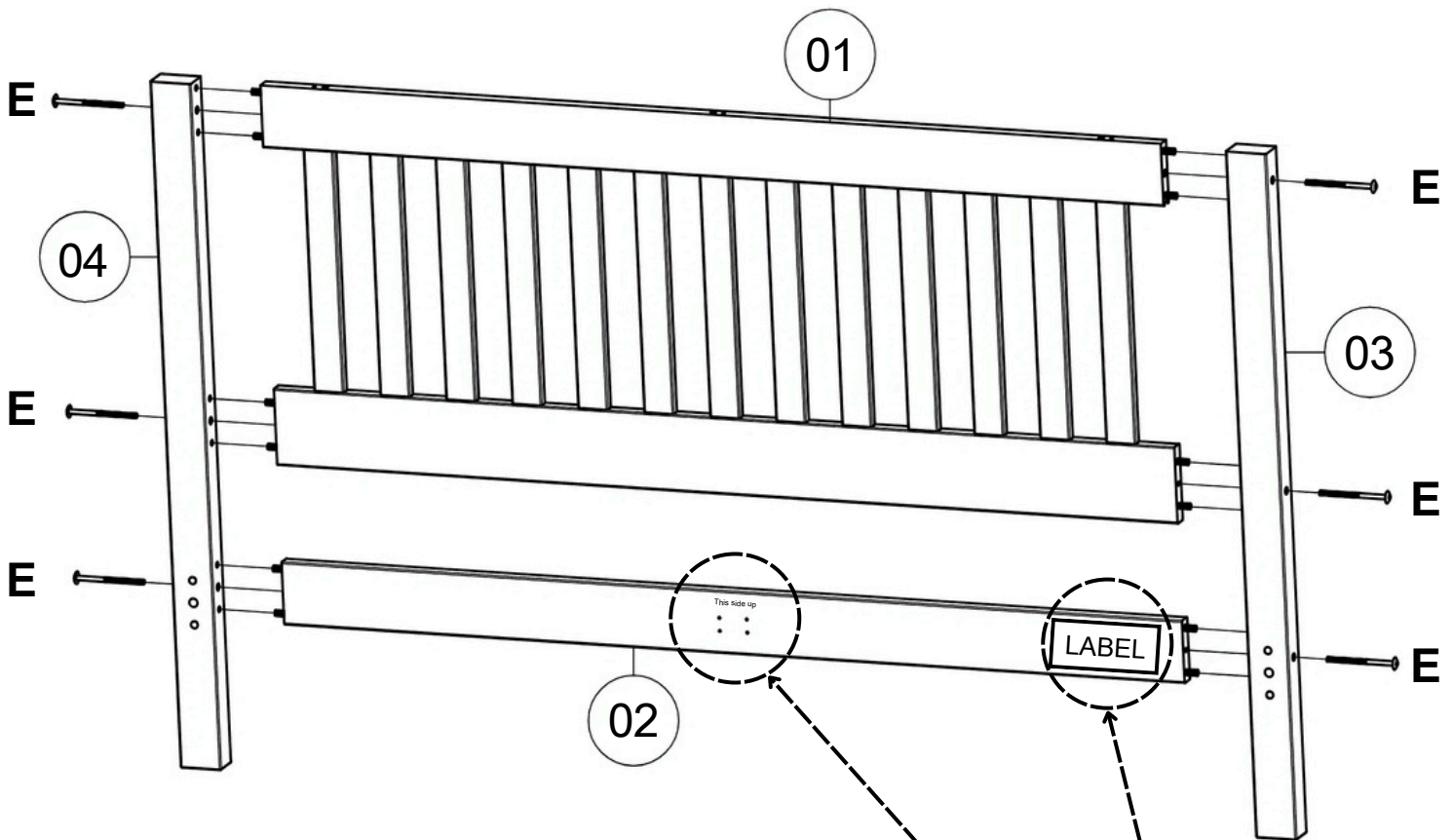

Please note the pre-marked holes and the label position.

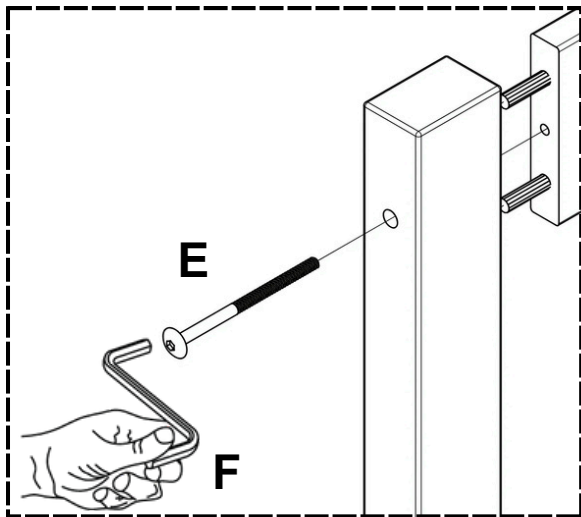

STEP 3

TOOLS REQUIRED:

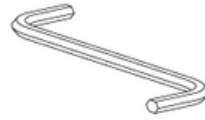

PARTS REQUIRED:

| | | | | | |
|----|----------------------|----|----|---------------------|----|
| 05 | Footboard Panel | x1 | 07 | Left Footboard Post | x1 |
| 06 | Right Footboard Post | x1 | | | |

HARDWARE REQUIRED:

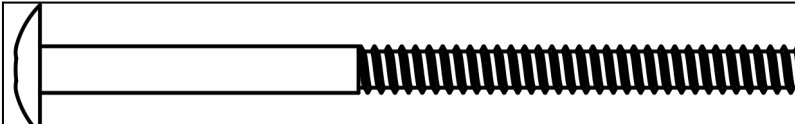
| | | | |
|---|---|--------------------|----|
| E |  | 7 X 100 mm (Black) | x2 |
|---|---|--------------------|----|

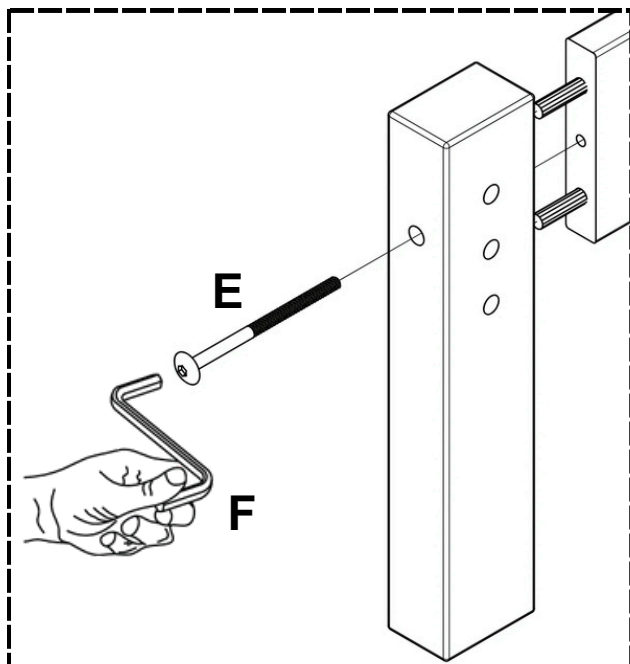
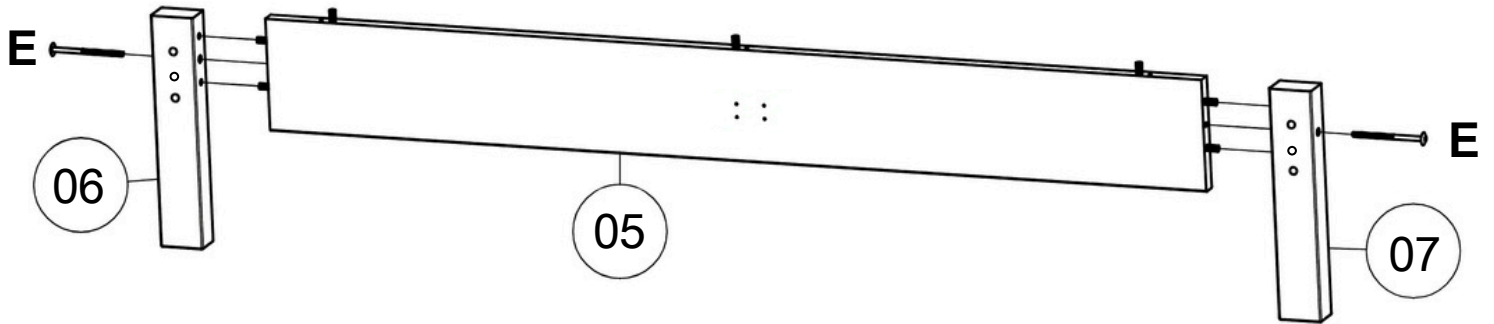



STEP 4

TOOLS REQUIRED:

PARTS REQUIRED:

| | | |
|----|----------|----|
| 08 | Siderail | x2 |
|----|----------|----|

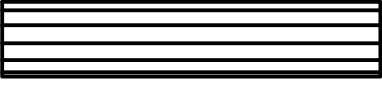
HARDWARE REQUIRED:

| | | |
|---|--|----|
| A |  10 X 50 mm | x4 |
| H |  GLUE | x1 |

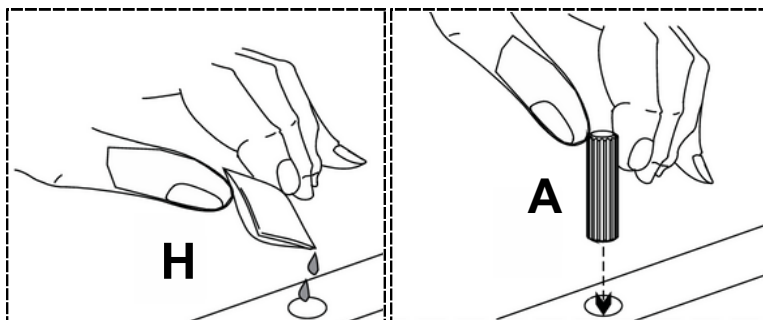
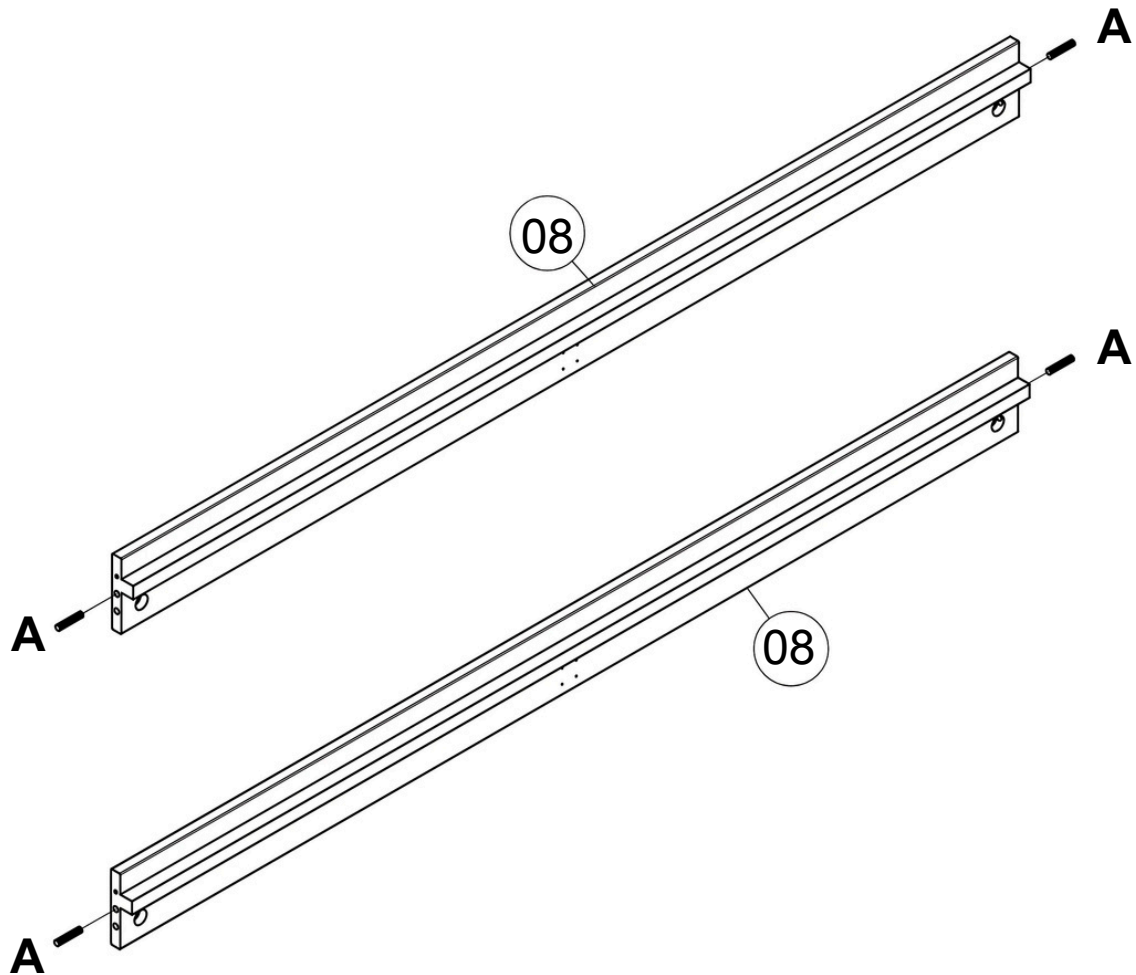

Glue must be added to the dowel holes on parts 08.

STEP 5

TOOLS REQUIRED:

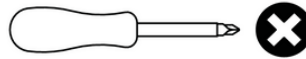

PARTS REQUIRED:

| | | | | | |
|----|----------|----|----|------------------|----|
| 08 | Siderail | x2 | 09 | Siderail Support | x2 |
|----|----------|----|----|------------------|----|

HARDWARE REQUIRED:

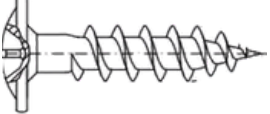
| | | |
|---|--|----|
| K |  4.0 x 35mm | x8 |
|---|--|----|

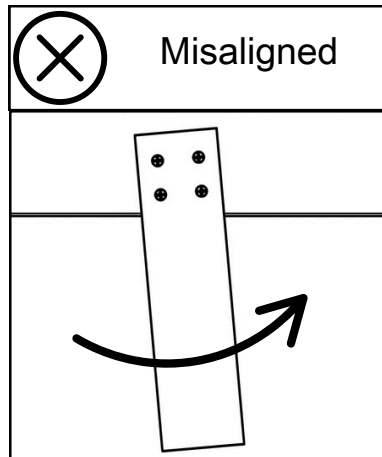
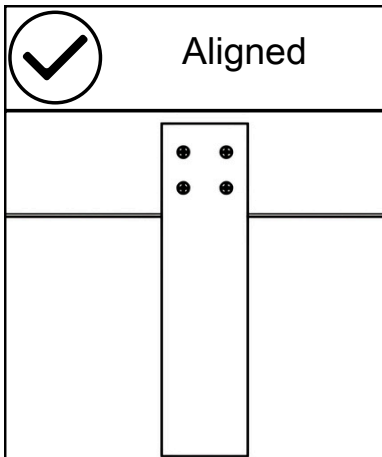
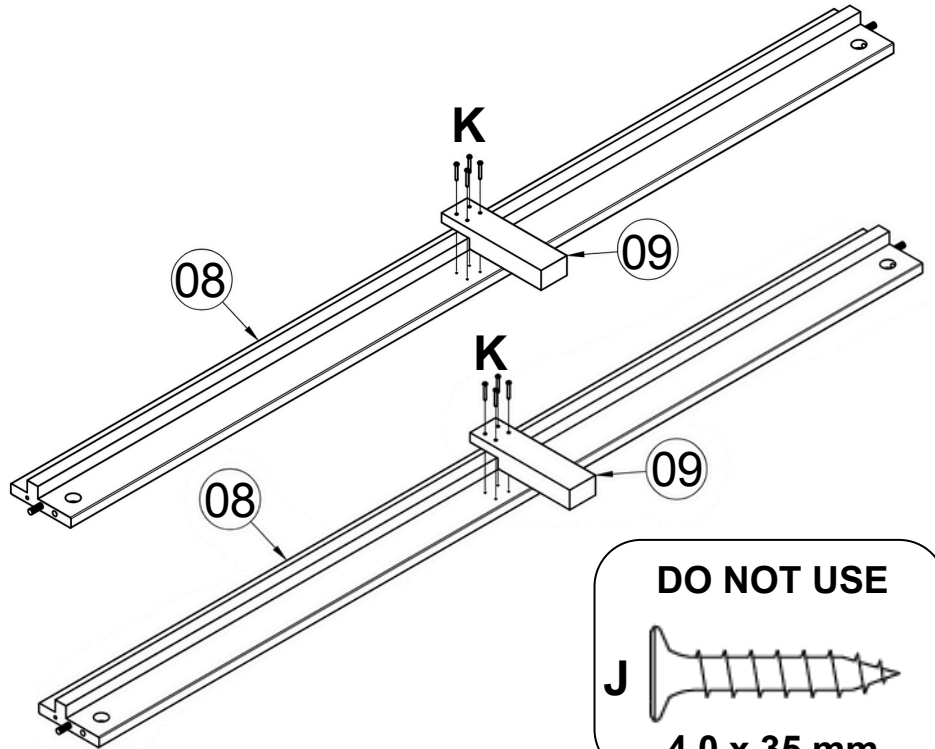
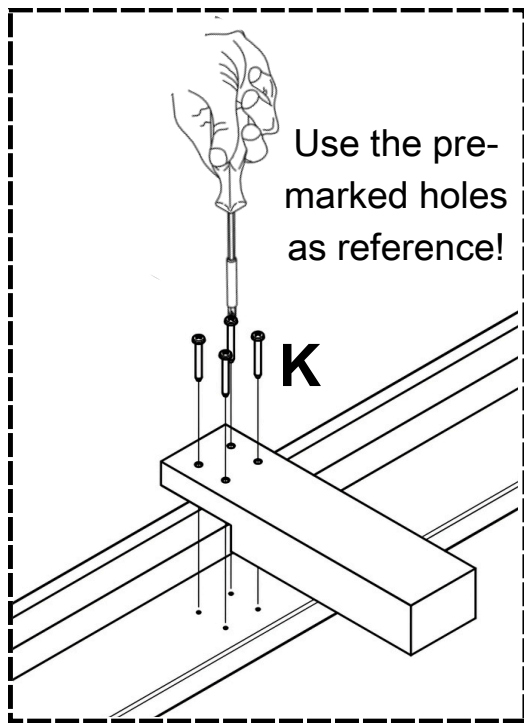

The Siderail Support (9) must be mounted perpendicular to the siderail (8). Make sure the part is not misaligned. Mount the Siderail Support (9) with its cut-out face flush against the underside of the siderail (8).

STEP 6

TOOLS REQUIRED:

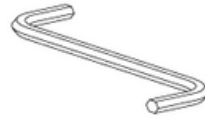

PARTS REQUIRED:

HARDWARE REQUIRED:

| | | |
|---|---------------------|----|
| C | | x4 |
| D | 1/4 X 90 mm (Black) | x4 |
| O | 7 X 80 mm (Black) | x4 |

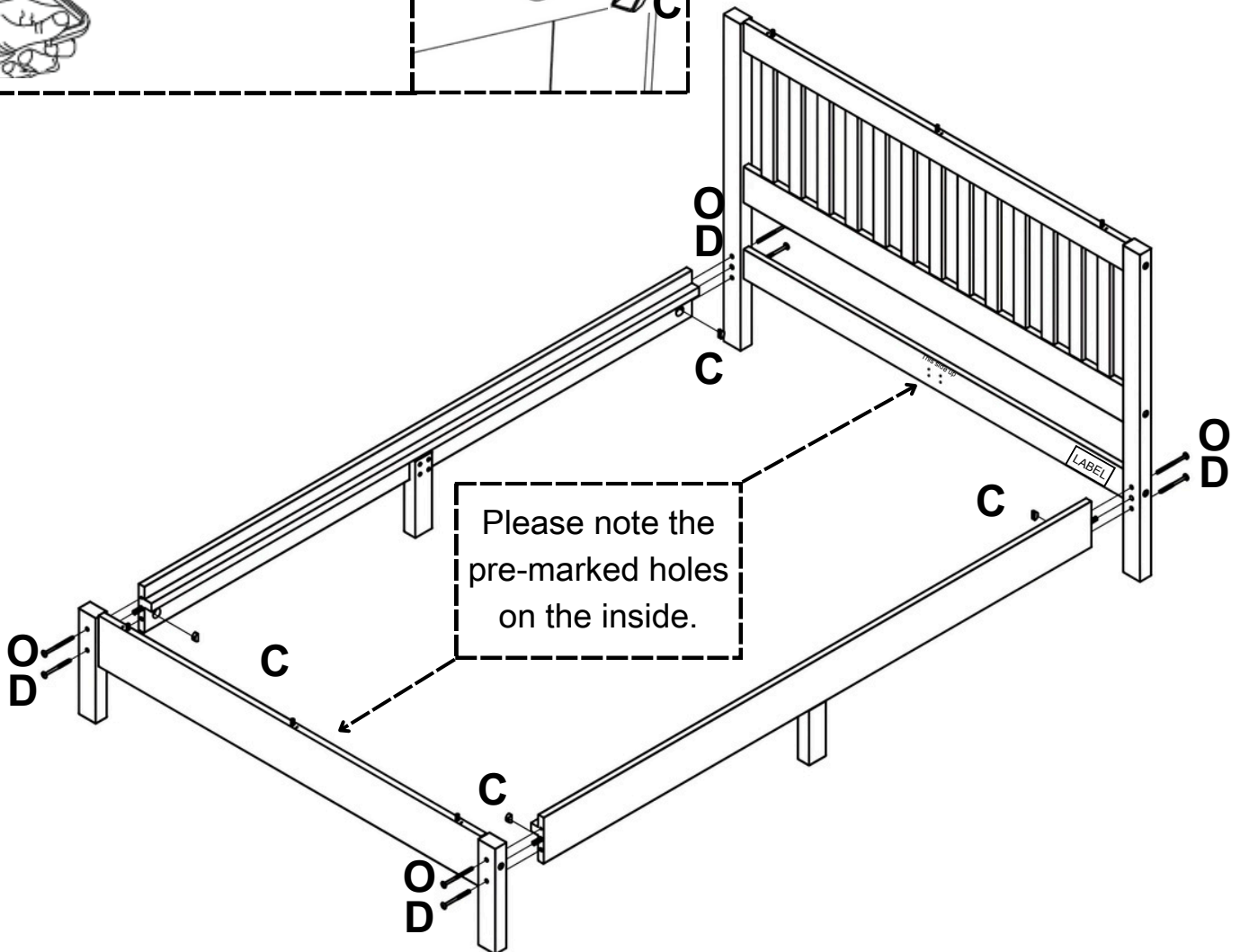
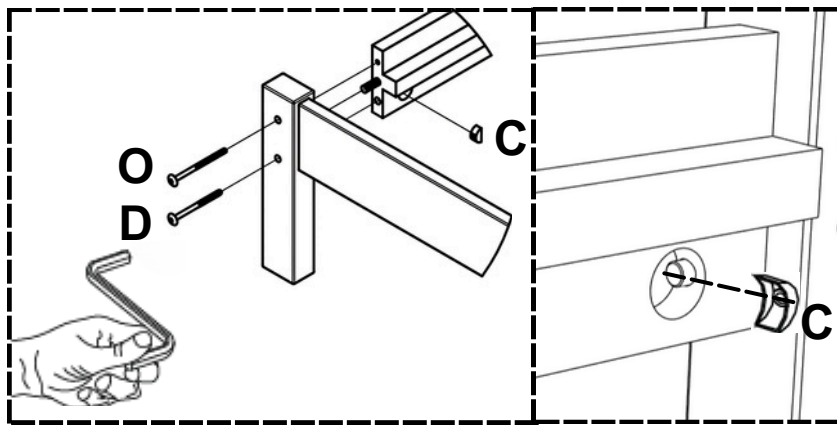

STEP 7

TOOLS REQUIRED:

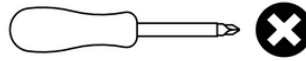

PARTS REQUIRED:

HARDWARE REQUIRED:

| | | |
|---|---|----|
| L |  4.0 x 16 mm | x8 |
| M |  | x2 |

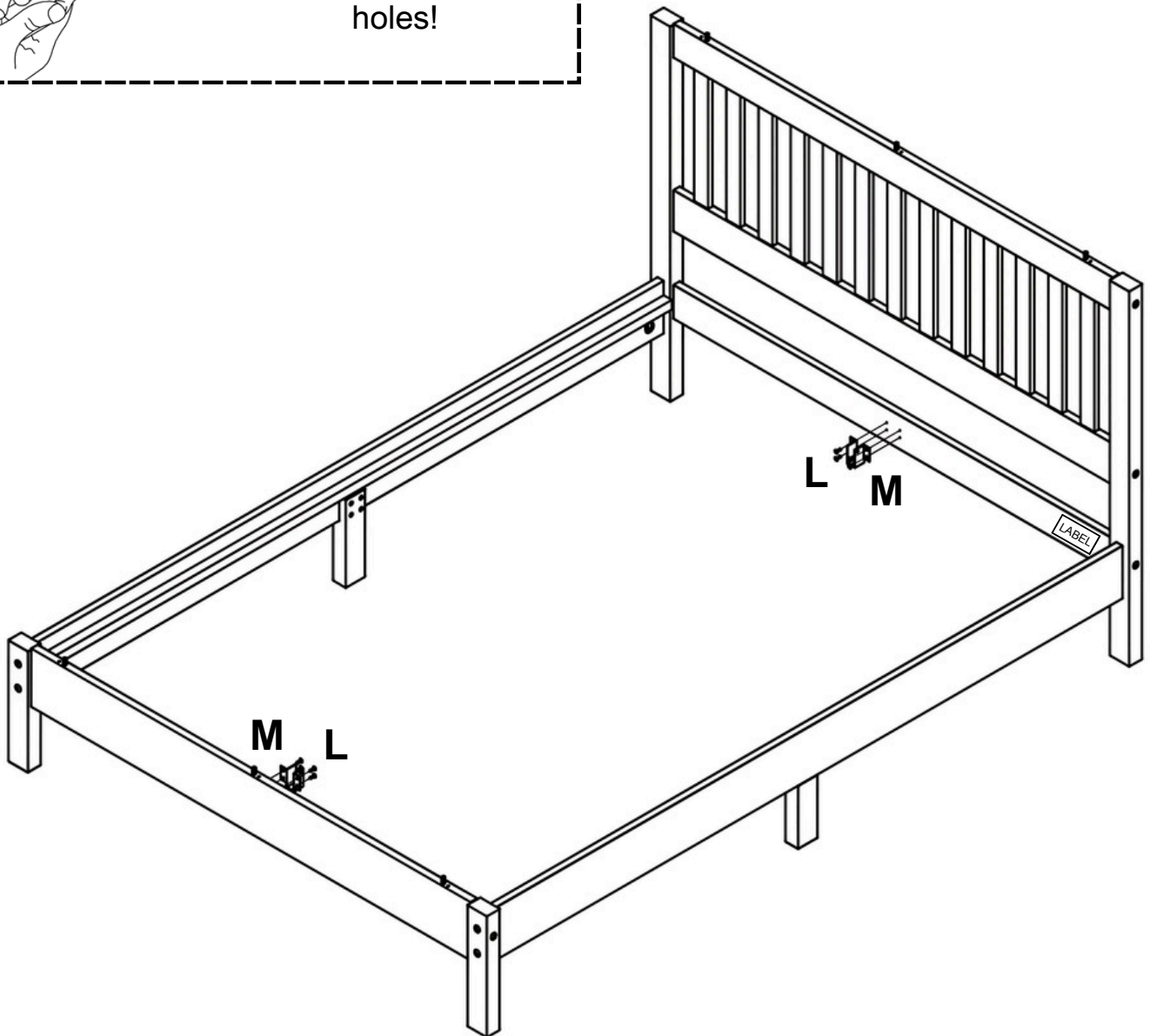
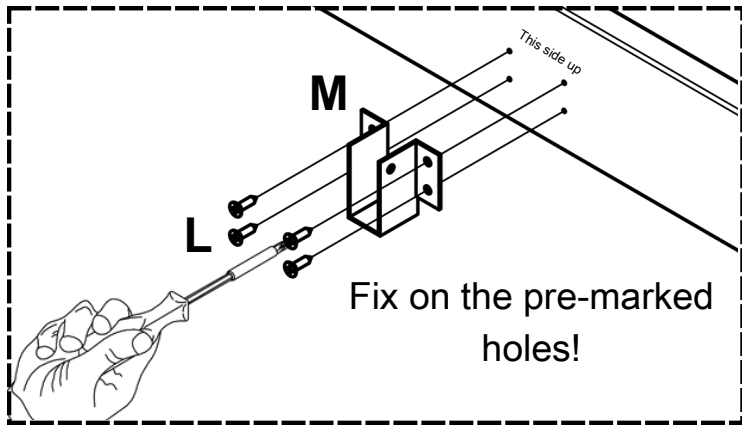

STEP 8

TOOLS REQUIRED:

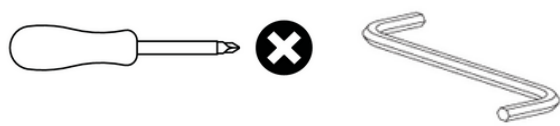

PARTS REQUIRED:

| | | |
|----|---------------------|----|
| 10 | Centre Support Rail | x1 |
| 11 | Centre Support Leg | x2 |

HARDWARE REQUIRED:

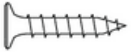
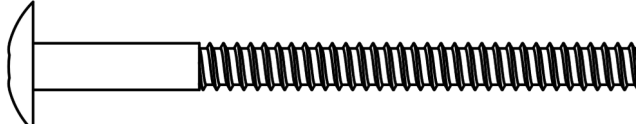
| | | |
|---|--|----|
| L |  4.0 x 16 mm | x2 |
| N |  7 x 80 mm (Yellow) | x2 |

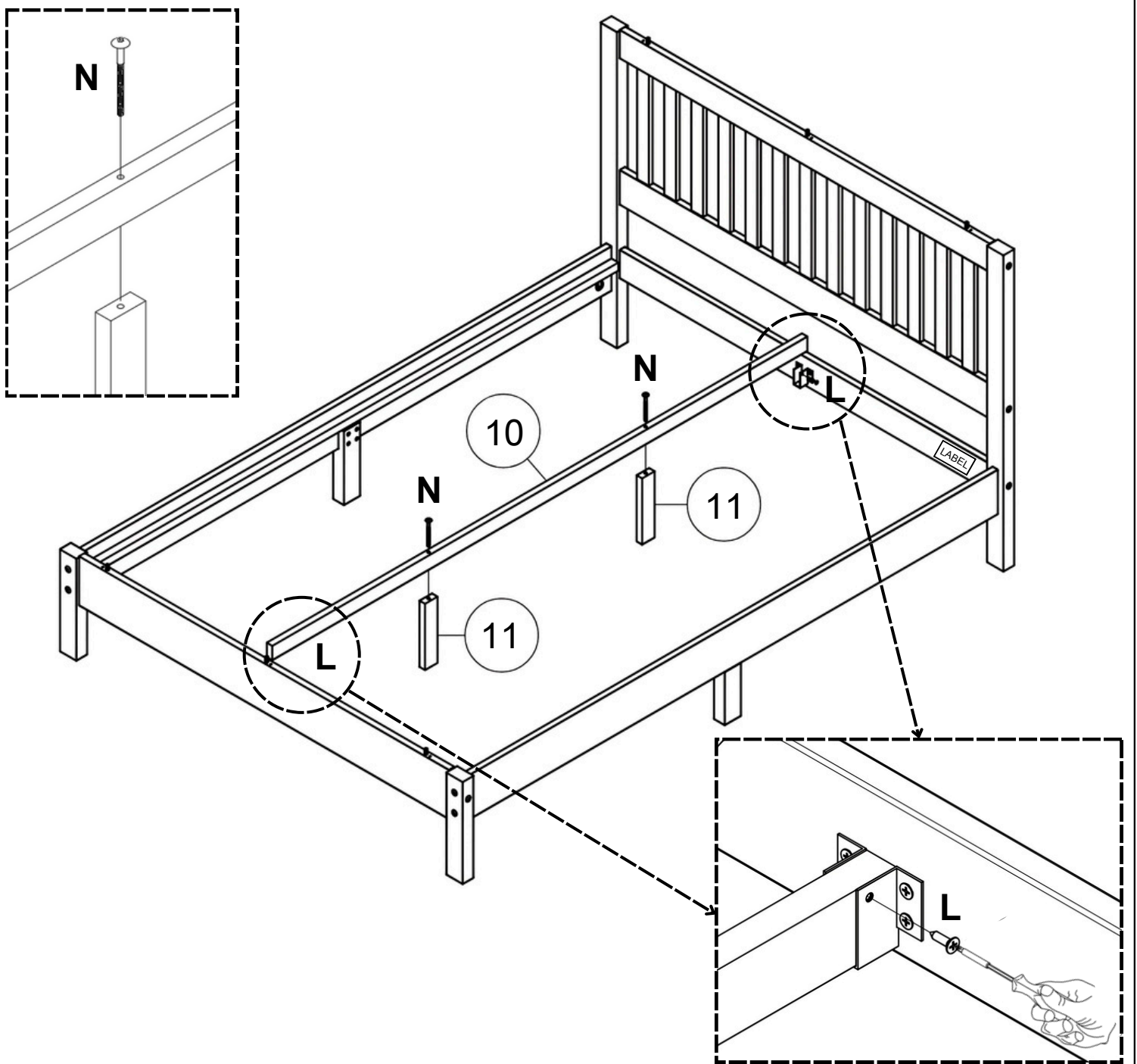

STEP 9

TOOLS REQUIRED:

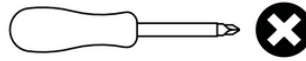

PARTS REQUIRED:

| | | |
|----|---------------|----|
| 12 | Top Crossbeam | x2 |
|----|---------------|----|

HARDWARE REQUIRED:

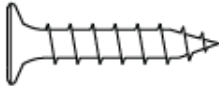
| | | |
|---|---|----|
| J |  4.0 x 35 mm | x6 |
|---|---|----|

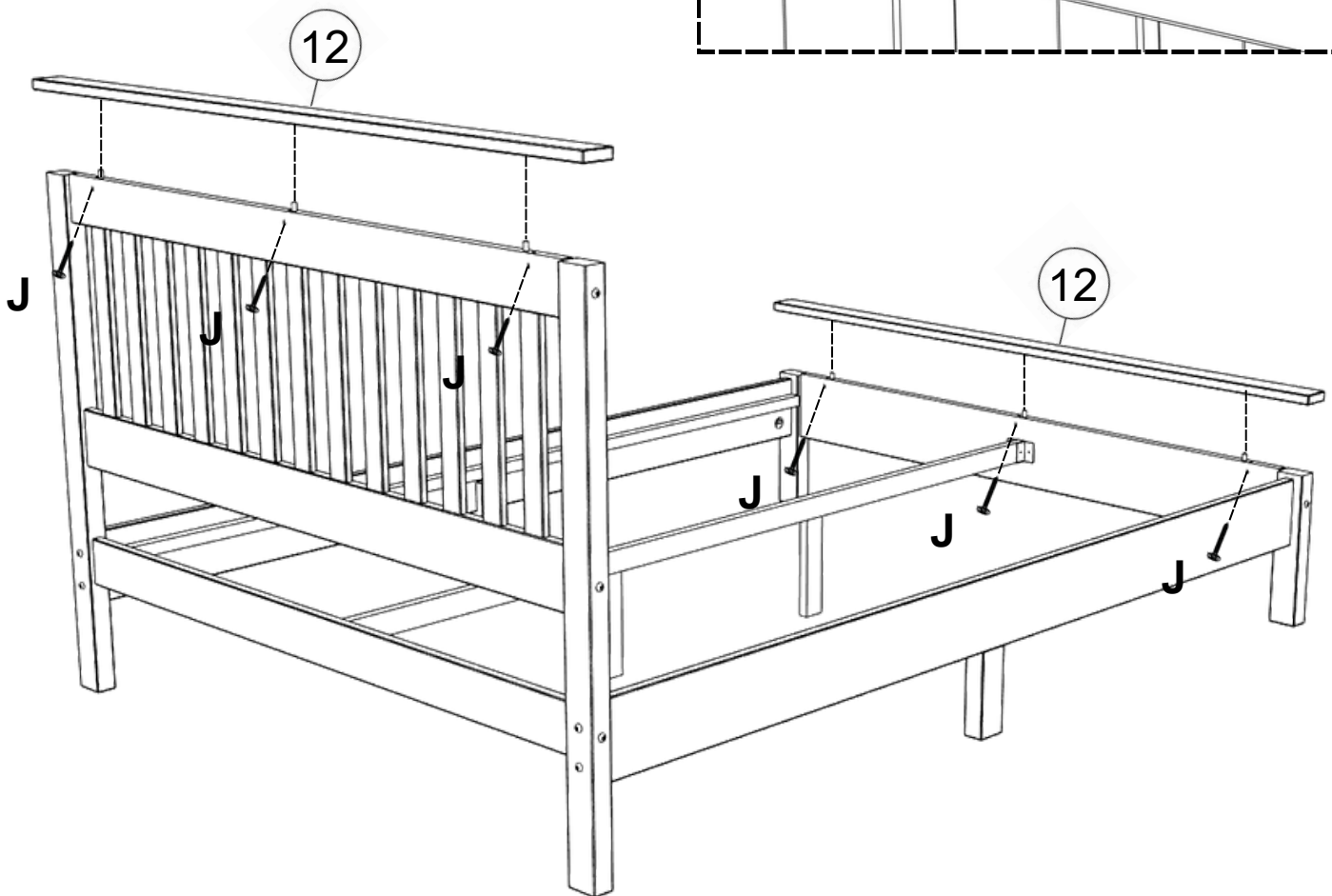
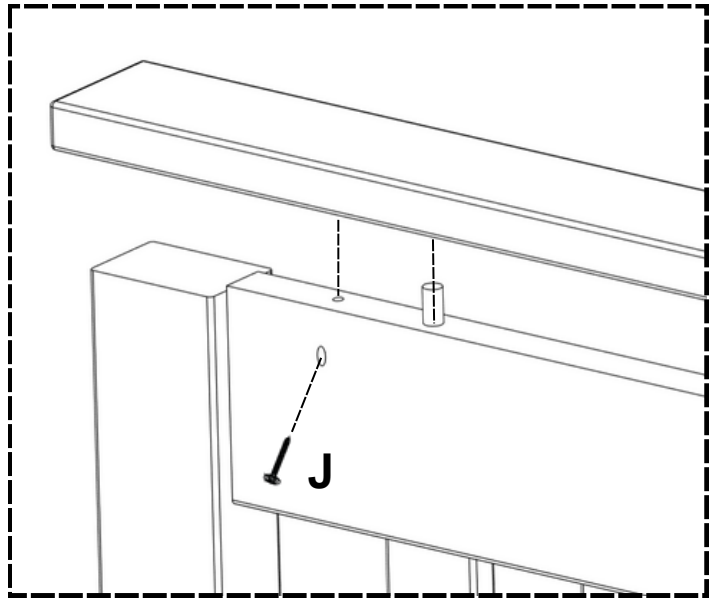

STEP 10

TOOLS REQUIRED:

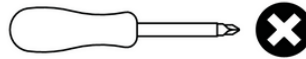

PARTS REQUIRED:

| | | | | | |
|----|-----------------|----|----|-----------------|----|
| 13 | Slats (3 Holes) | x5 | 14 | Slats (2 Holes) | x8 |
|----|-----------------|----|----|-----------------|----|

HARDWARE REQUIRED:

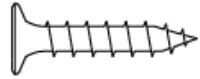
| | | | |
|---|---|---|-----|
| G | (SPACER) (WOODEN) |  | x2 |
| I |  | 3.5 x 30 mm | x31 |

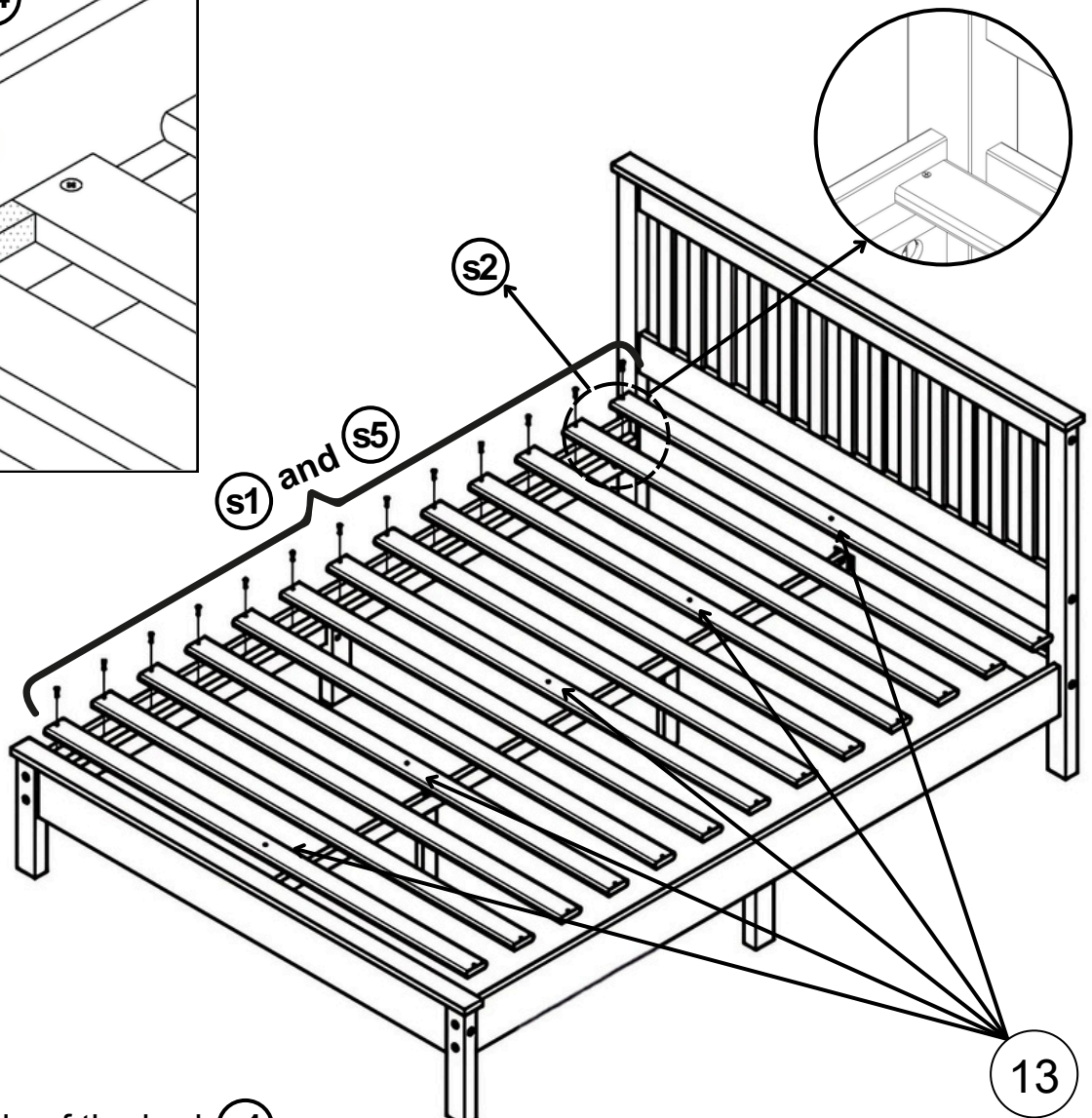
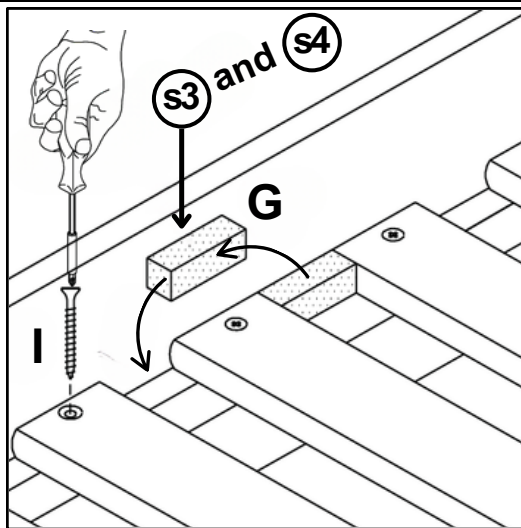

- Start on one side of the bed. (s1)
- Place the first slat adjacent to the headboard (Part 13). (s2)
- Use the spacer as shown to ensure correct spacing between the slats. (s3)
- Continue placing all the slats one by one, using the spacer. (s4)
- Fix all the slats to the first side rail (Part 8). (s5)

STEP 10

TOOLS REQUIRED:

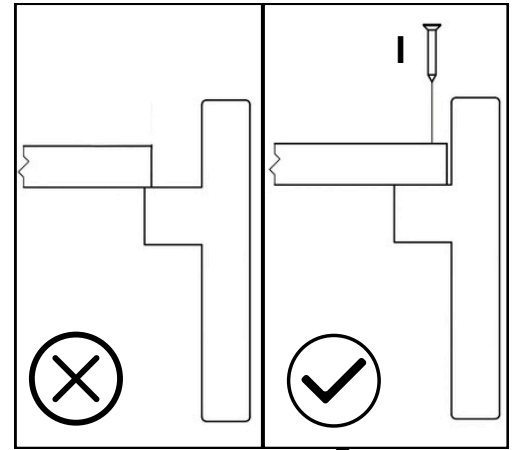
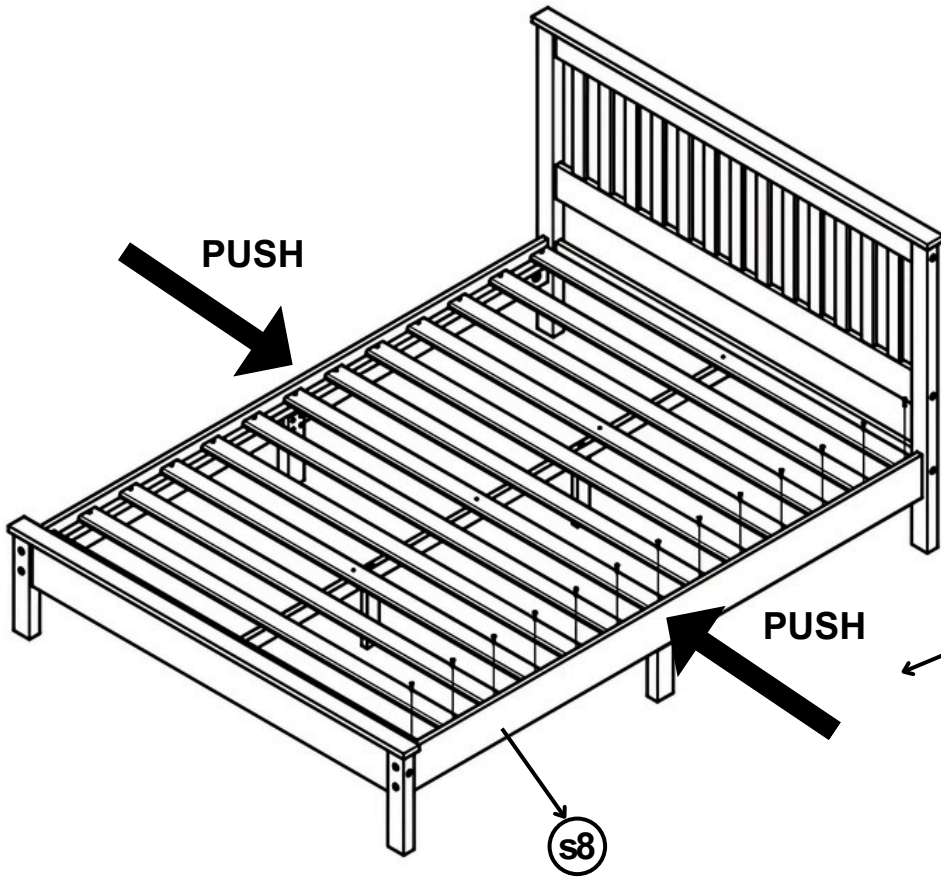
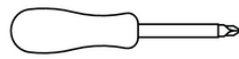

- Push the second side rail tightly against the slats. (s6)
- Use the spacer as shown to ensure correct spacing is maintained. (s7)
- Fix all the slats (Part 13 or 14) to the second side rail (Part 8). (s8)

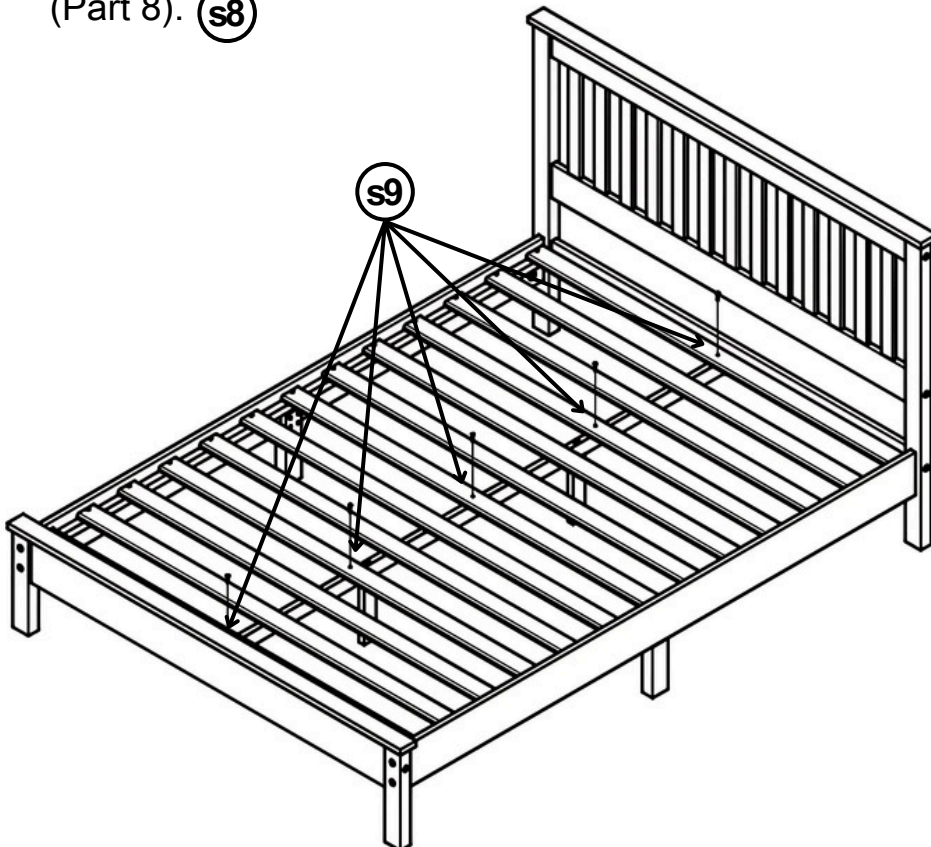
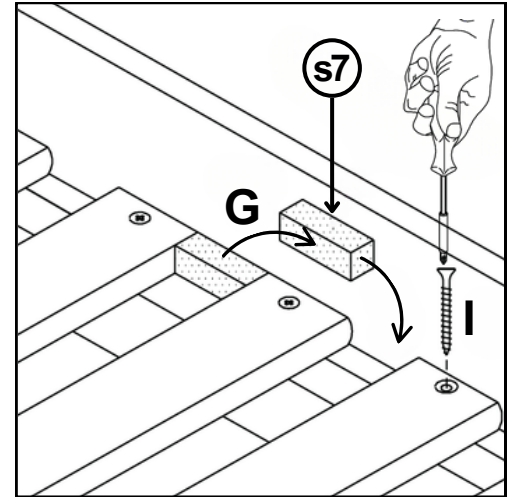

- If the central rail (Part 10) is misaligned, align it with the hole in the slat (Part 13). Once aligned, fix all the five central screws (Hardware I). (s9)