

BMC70TC

Assembly Instructions

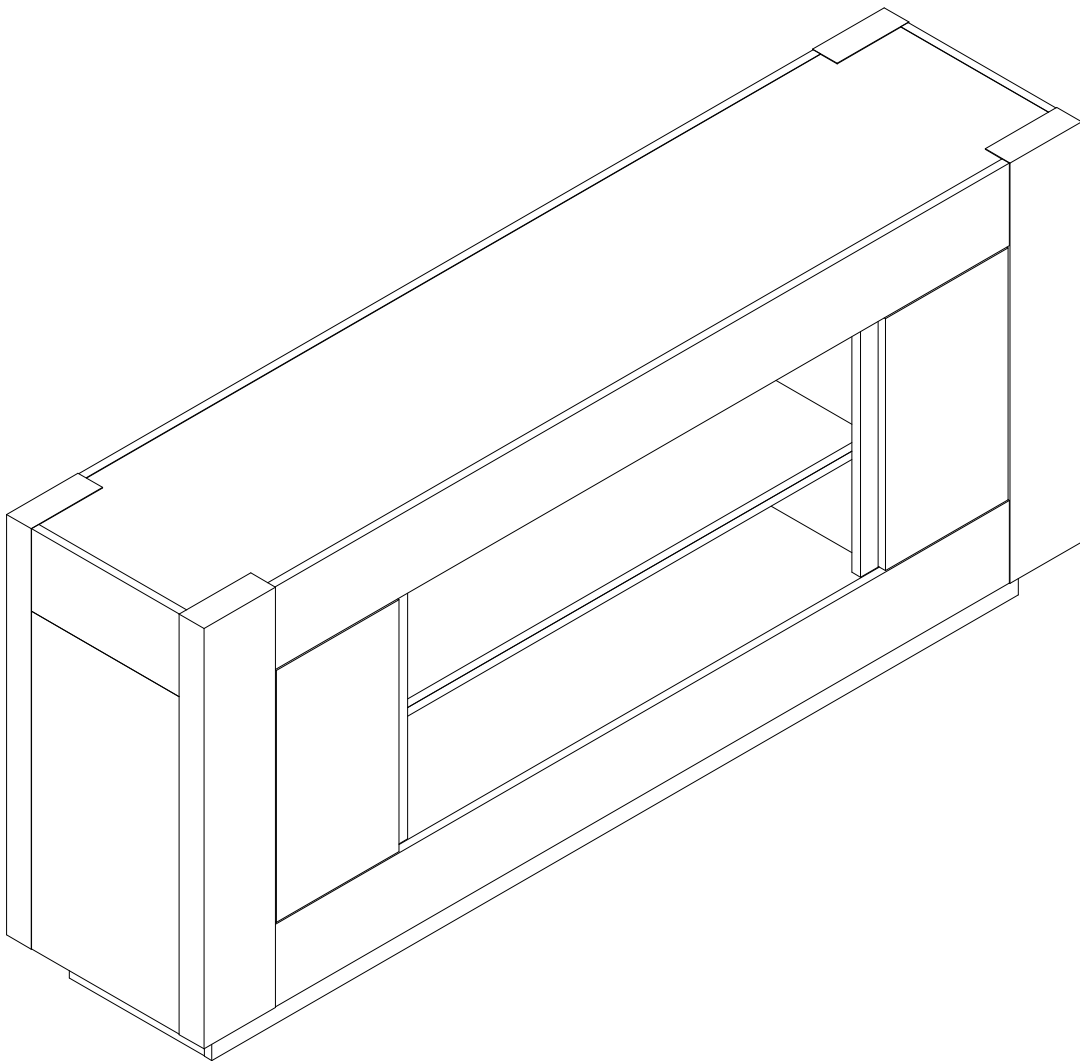

Date 2025-04-25 Rev.01-A

General Assembly Guidelines

- I. Ensure that all parts and hardware are available before beginning assembly.
- II. Follow each step carefully to ensure the proper assembly of this product.
- III. Two people are recommended for ease in the assembly of this product.
- VI. A Phillips head screwdriver is required for the assembly of this product .

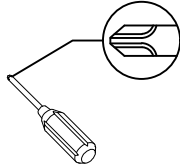

- V. The provided glue is to secure wood dowels in place . When first inserting dowels , locate the appropriate hole for the dowel , place a small amount of glue in the hole and insert the dowel . Wipe away excess glue immediately.

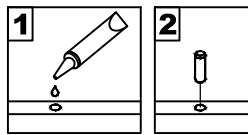

In future assembly steps when dowels are necessary to attach assembly parts together , place a small amount of glue on the end of the dowel before attaching parts together . Wipe away excess glue immediately.

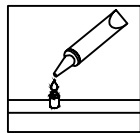

- VI. **HOW THE KNOCK DOWN (KD) ASSEMBLY SYSTEM WORKS**
 - 1.Screw the Cam Bolt into the pre-drilled hole on the panel. Make sure Cam Bolt goes into the pre-drilled hole on the end of panel for Cam Lock.
 - 2.Insert the Cam Lock into the pre-drilled large hole on the panel. Make sure the arrow on the face of Cam Lock points towards Cam Bolt.
 - 3.Take a Phillips screwdriver and rotate the Cam Lock clockwise to lock the Cam Bolt.
 - 4.Use the sticker to conceal the Cam.

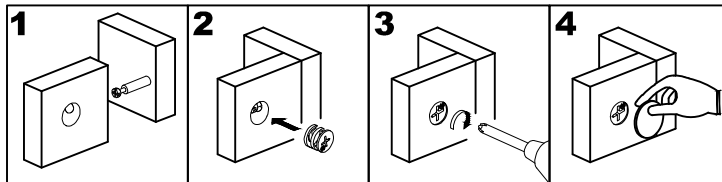



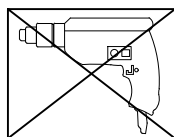



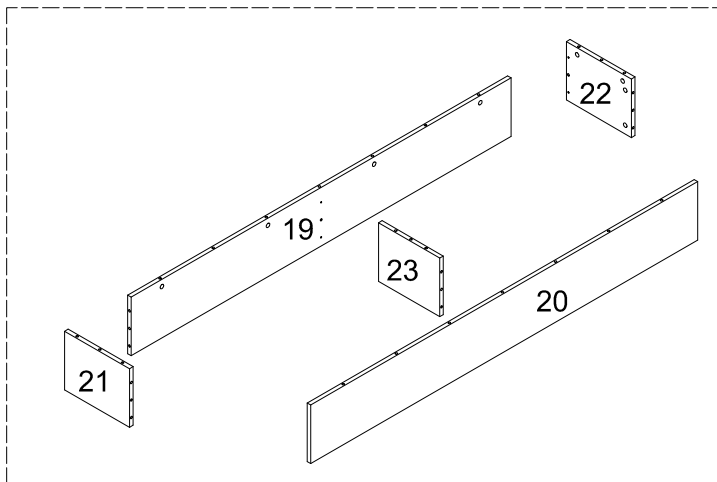
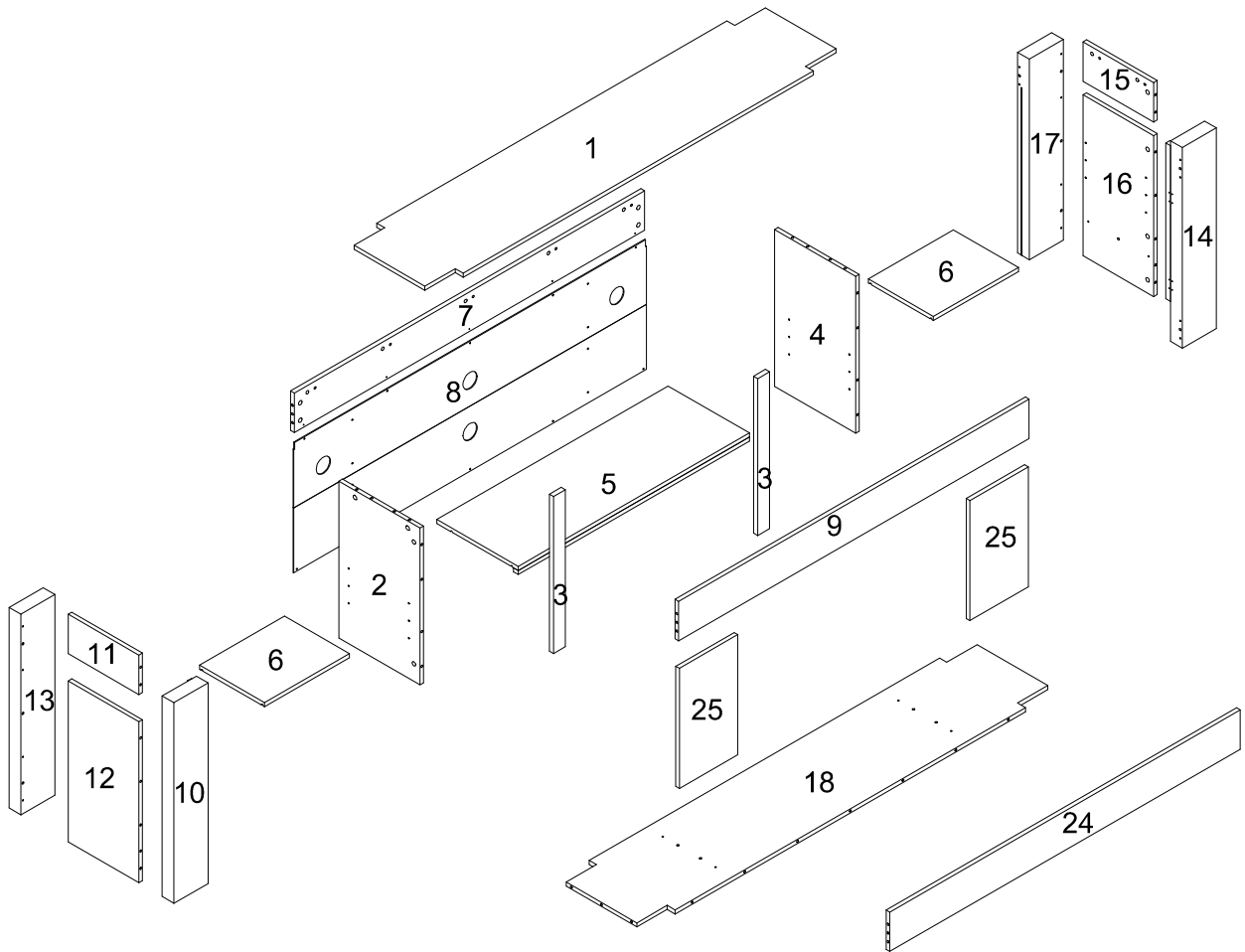



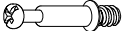

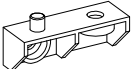

- VII. Power tools should not be used to assemble this product .



Parts List

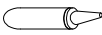

Hardware List

A		Ø8x30mm	Dowel	54 pcs
B		Ø6x35mm	Cam Bolt	62 pcs
C		Ø15x12mm	Cam Lock	62 pcs
D		Ø30mm	Cam Cover	62 pcs
E			Connector	14 pcs
F		1/4x12mm	Bolt	28 pcs
G		Ø3x15mm	Screw	18 pcs
H		Ø5x70mm	Screw	8 pcs
I		Ø35	Europe Hinge	4 pcs
J		Ø3.5x14mm	Screw	24 pcs
K		M4	Allen Wrench	1 pc
L		Ø6x50mm	Screw	4 pcs
M		Ø8x5x16mm	Shelf support pin	12 pcs
N		Ø10.5x8mm	Plastic Cover	8 pcs
O			Tipping Restraint Hardware	2 sets
P			Glue Tube	1 pc
Q			Plastic Wedge	4 pcs
R		Ø3x17mm	Flat-head Screw	4 pcs

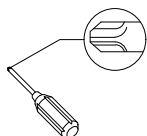

Philips head screwdriver required for assembly
(not included)

Step 1

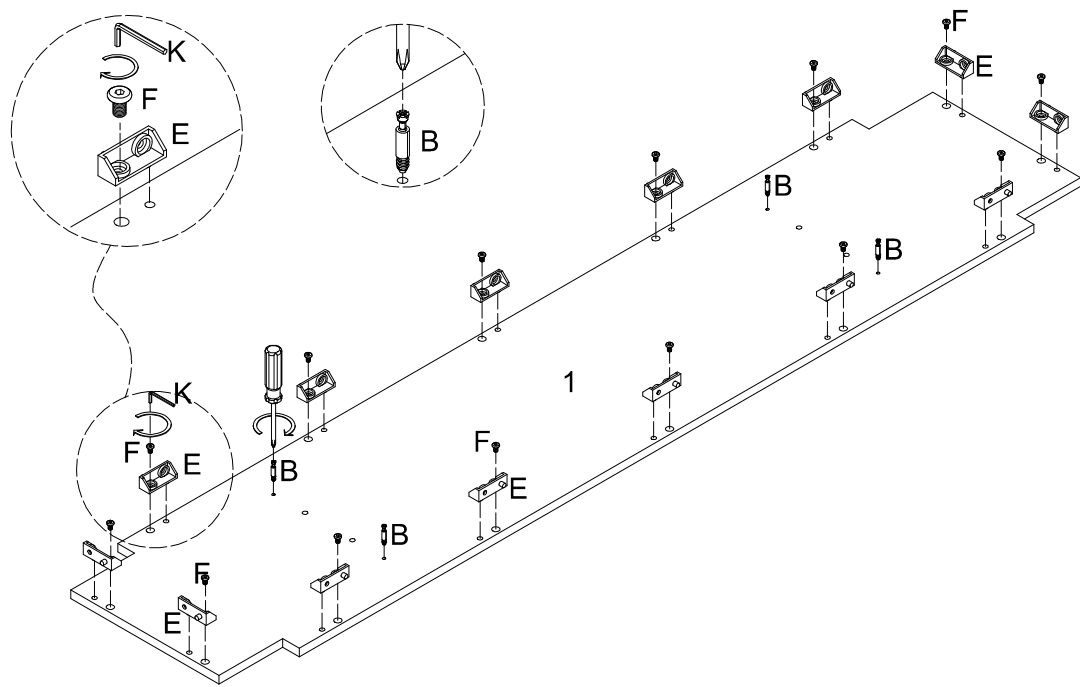

Step 2

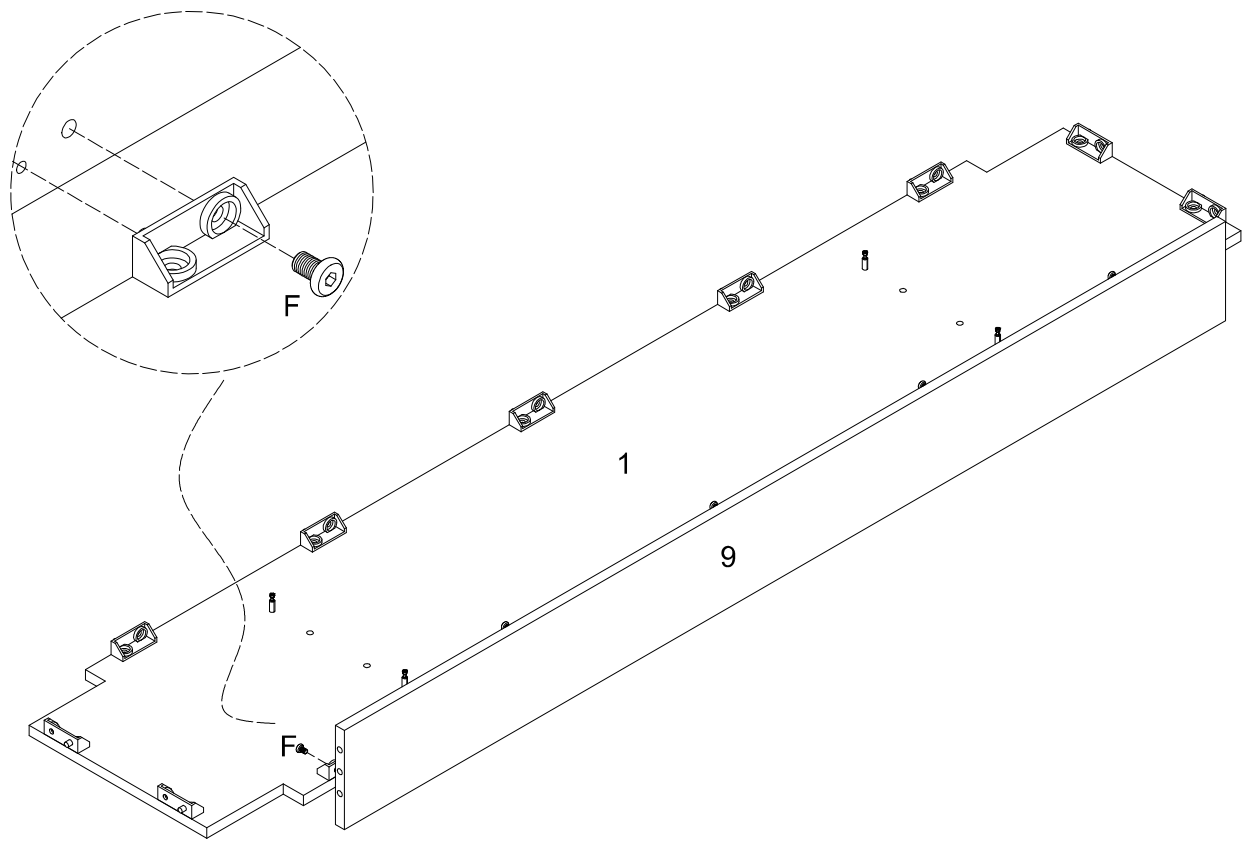

Step 3

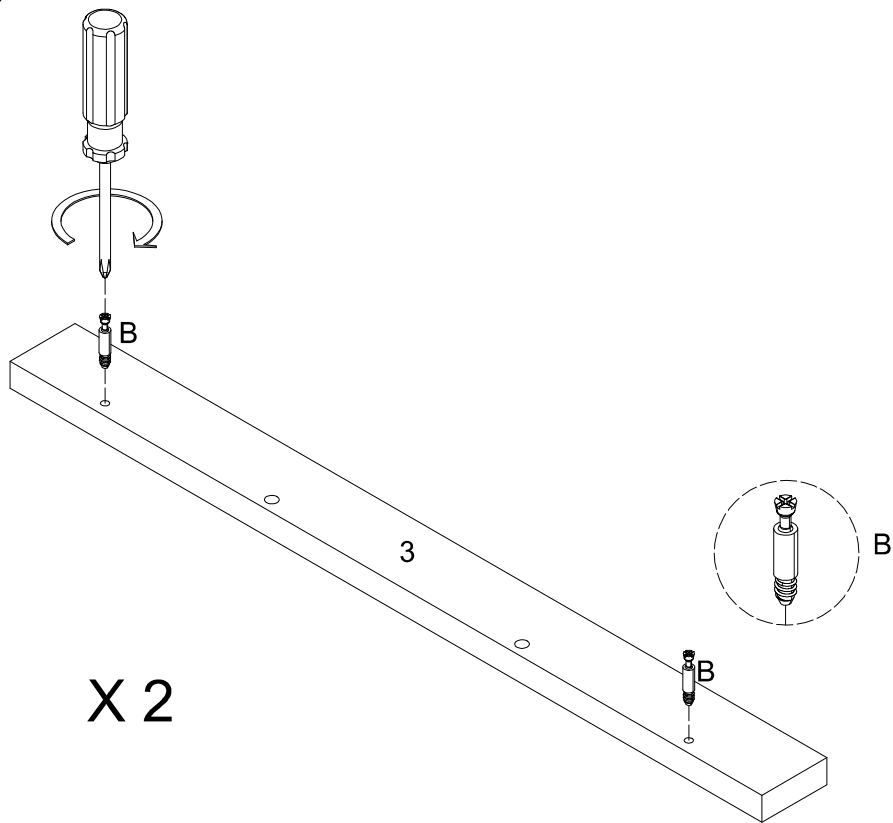
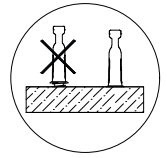

Step 4

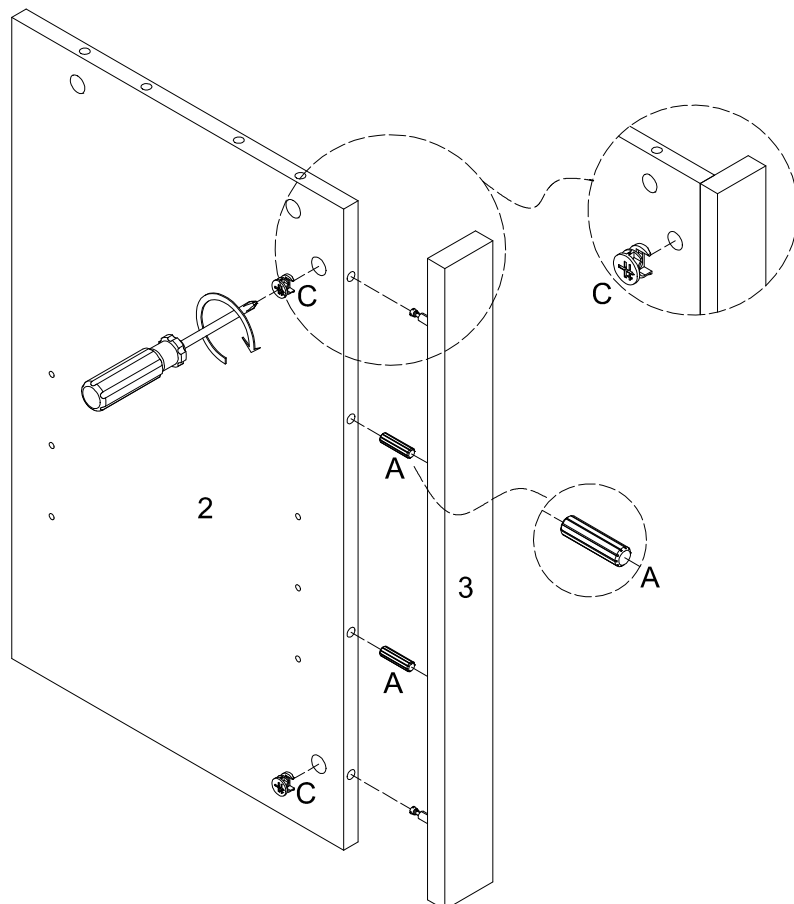

Step 5

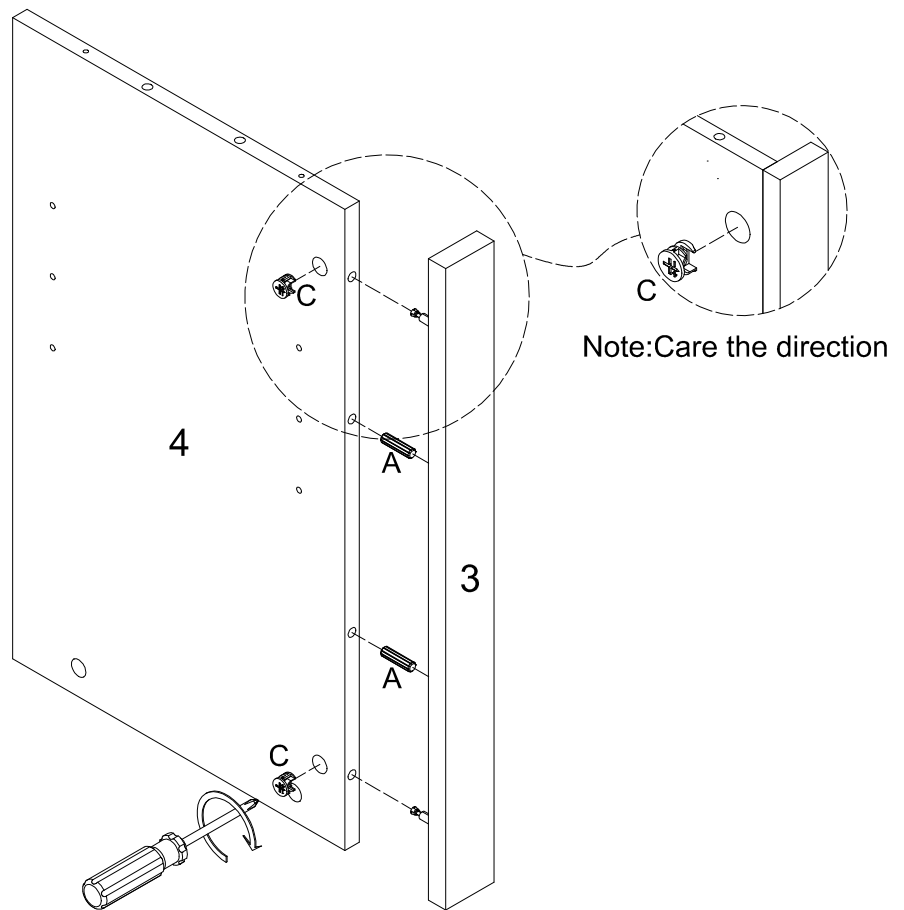

Step 6

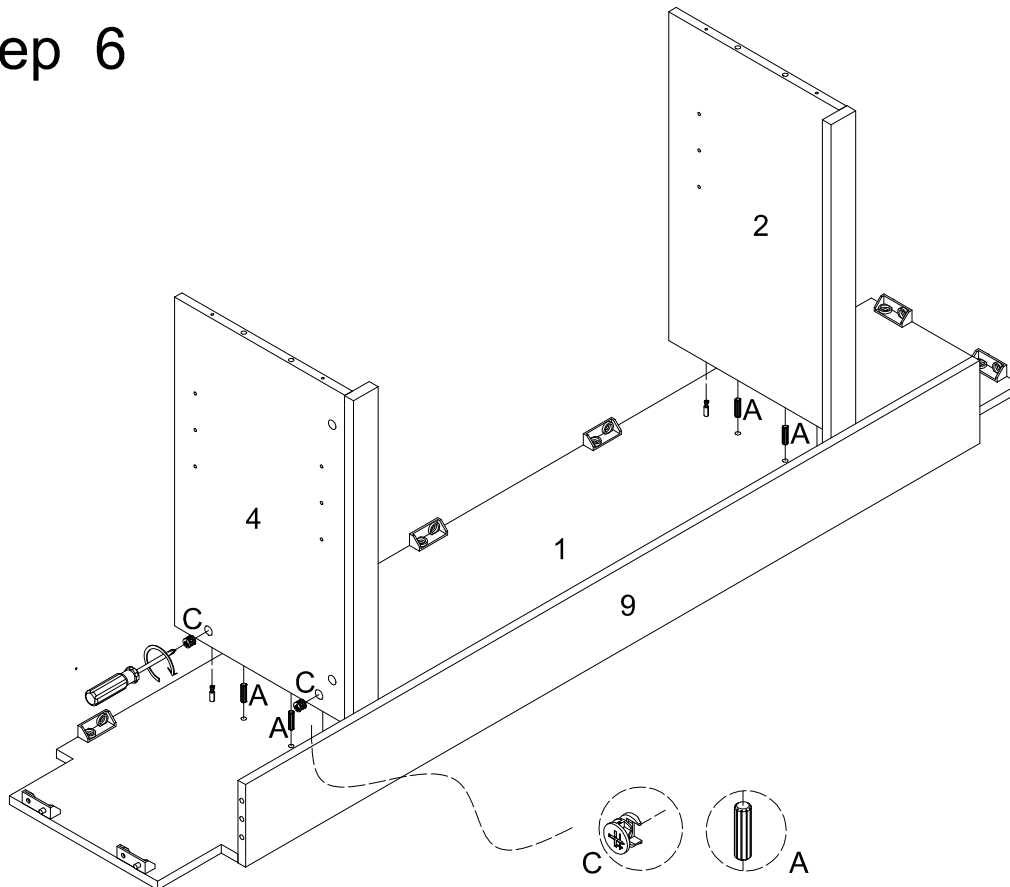

Step 7

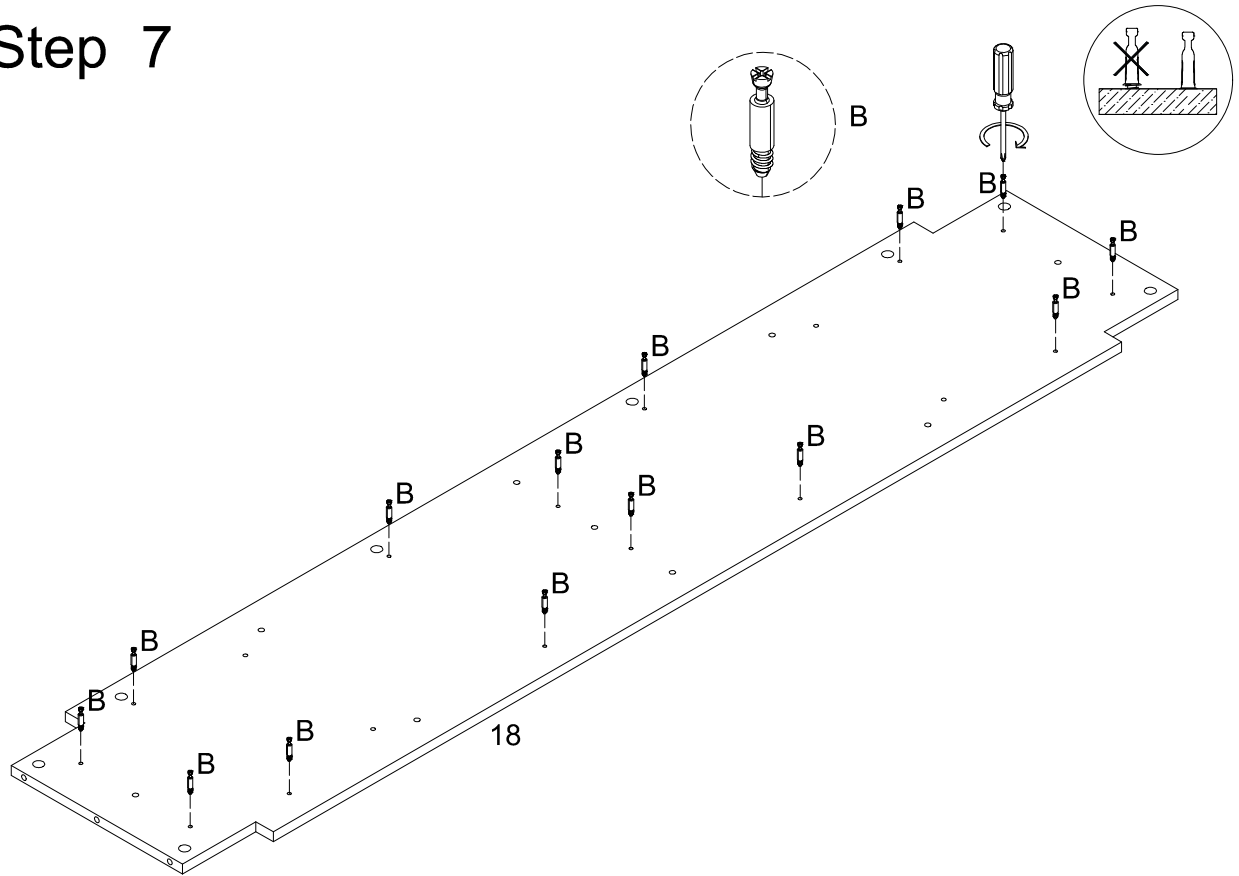

Step 8

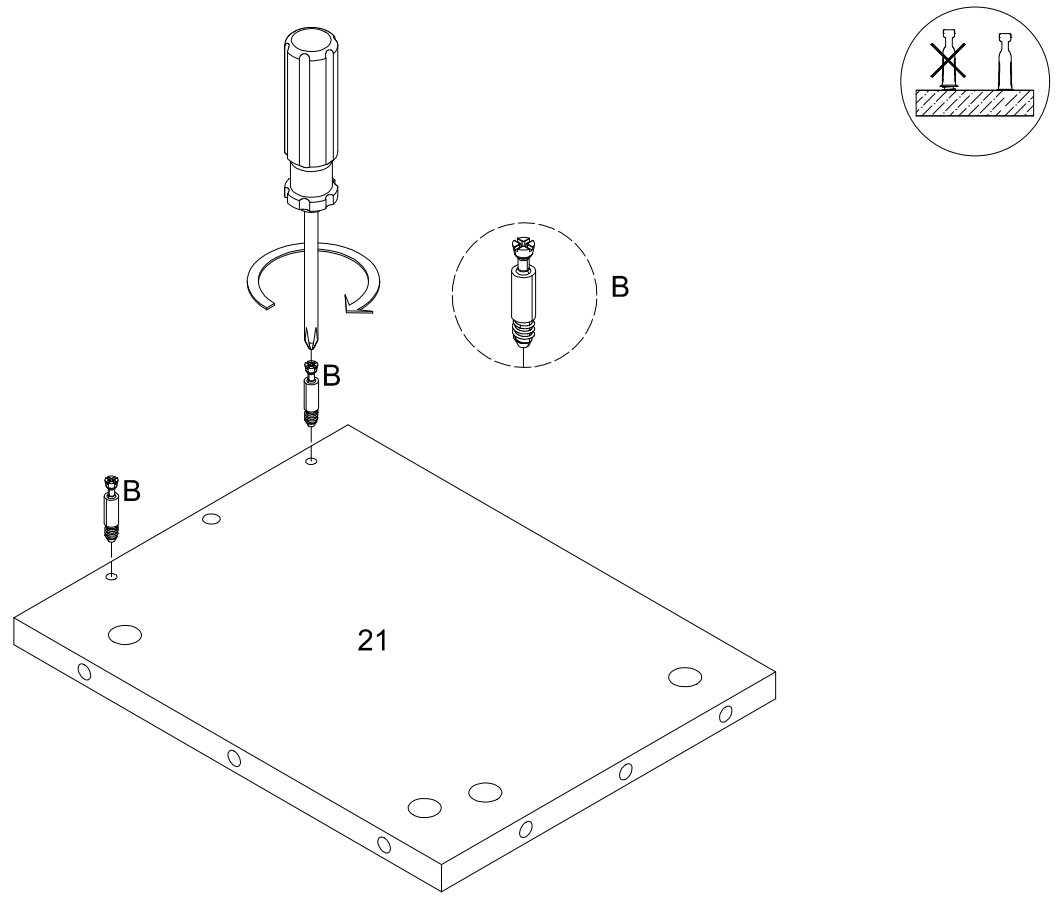

Step 9

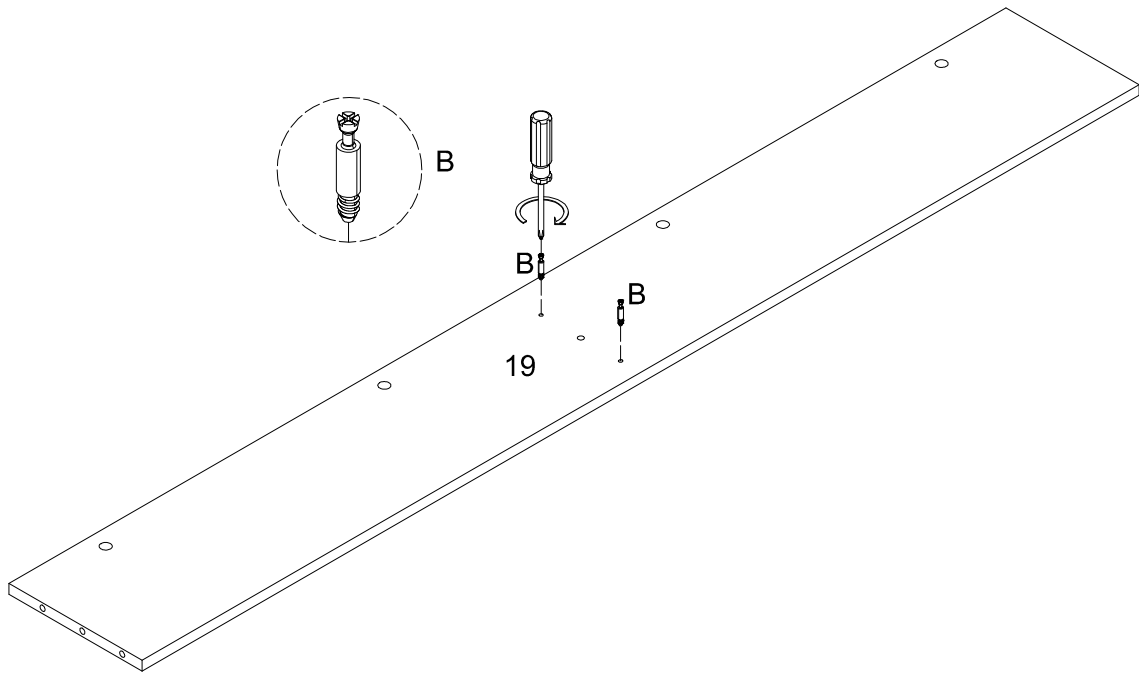
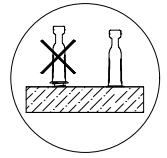

Step 10

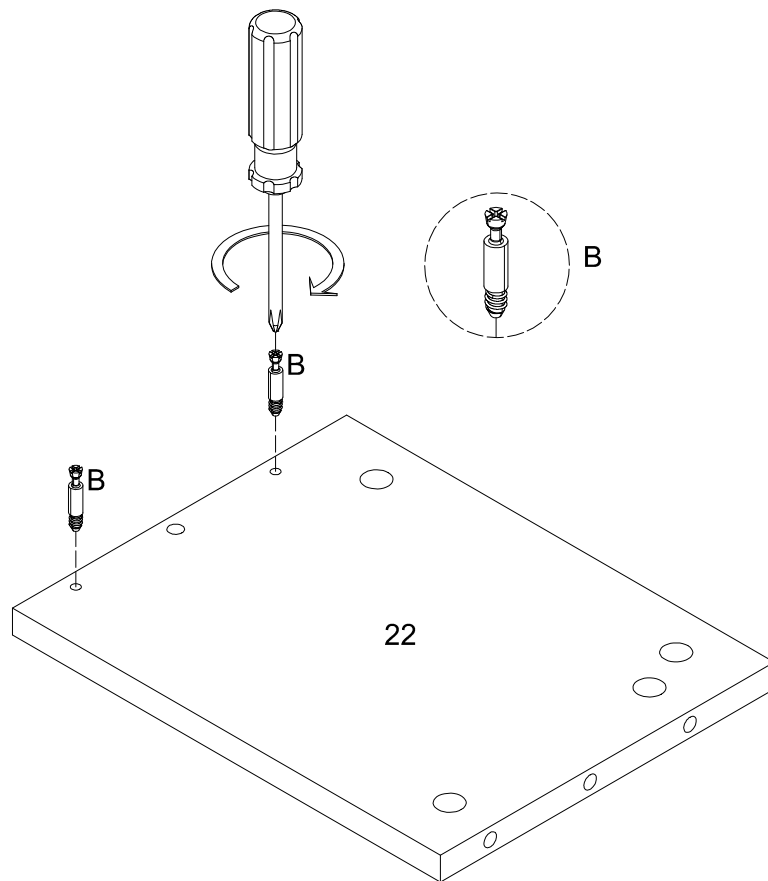
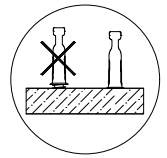

Step 11

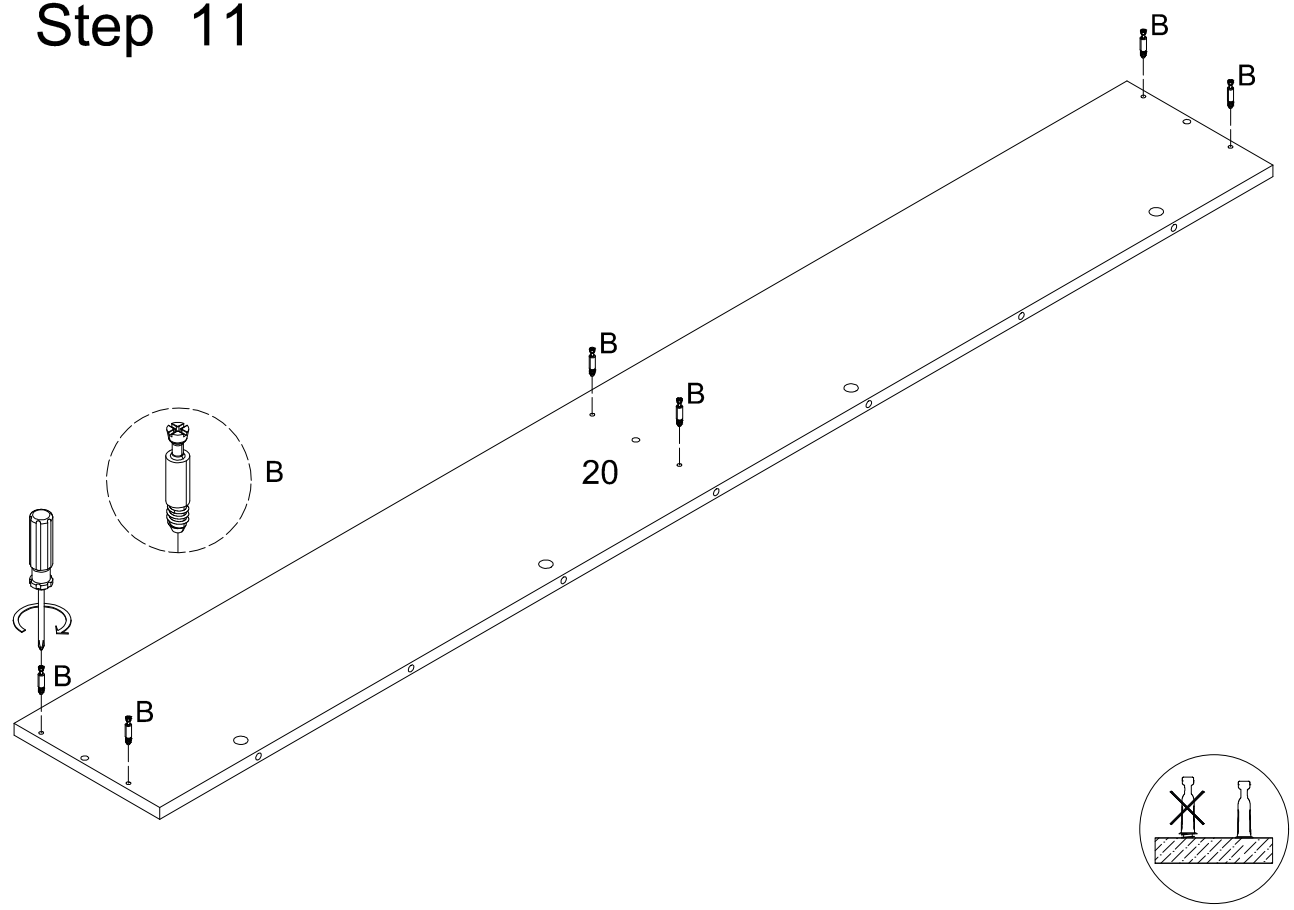

Step 12

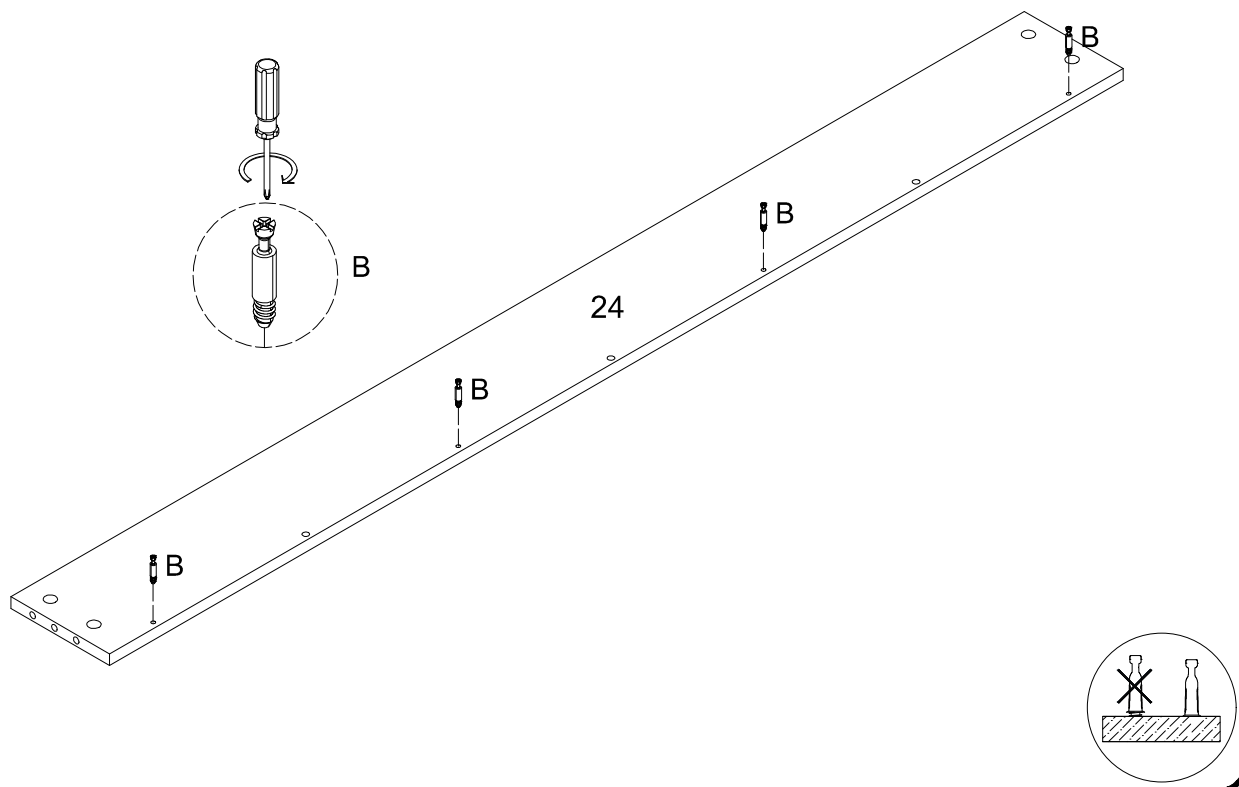

Step 13

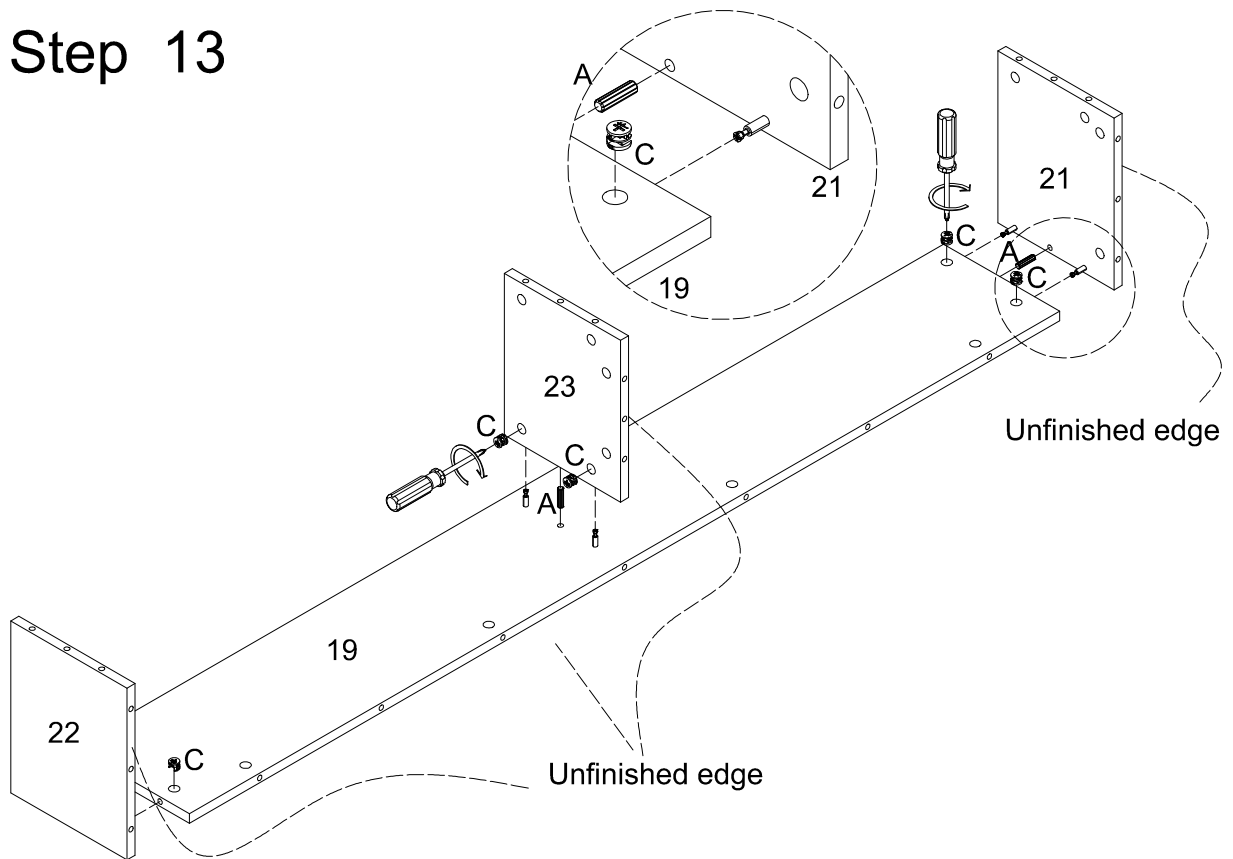

Step 14

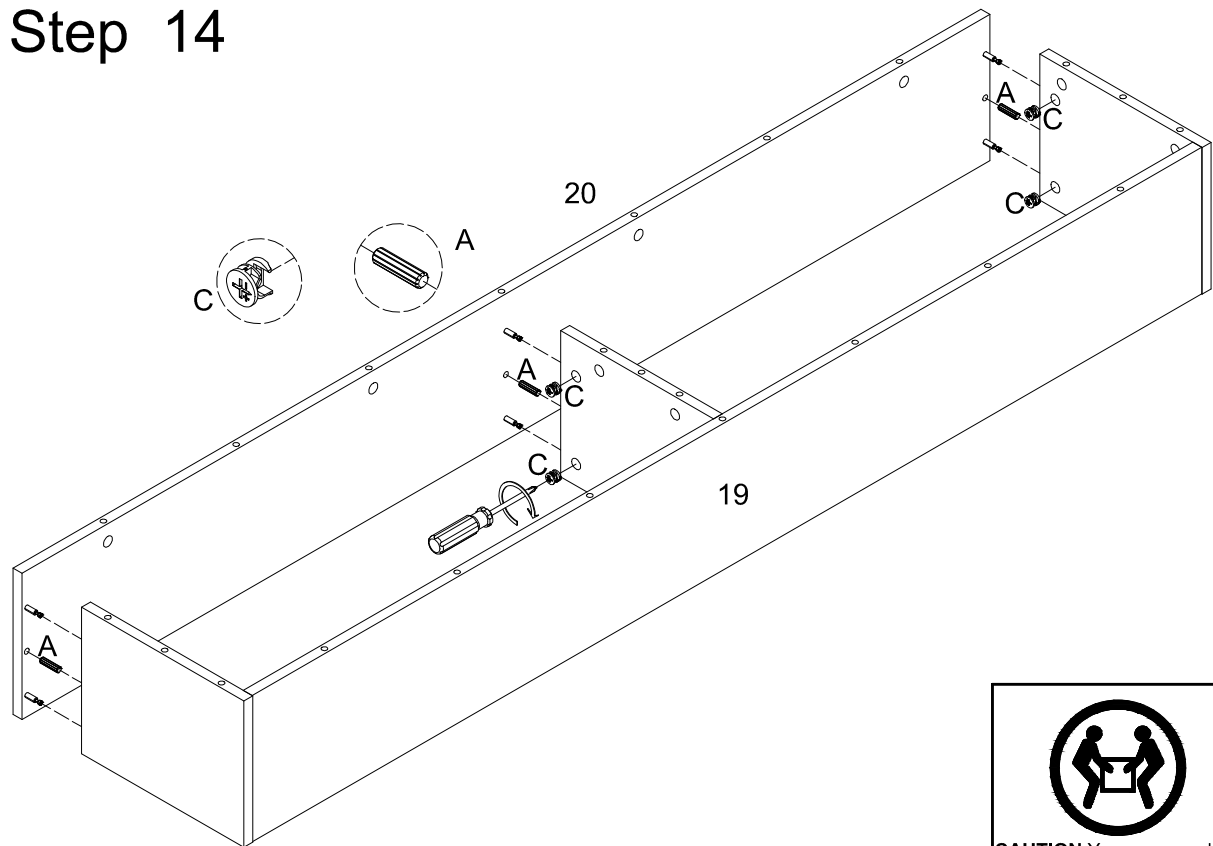

Step 15

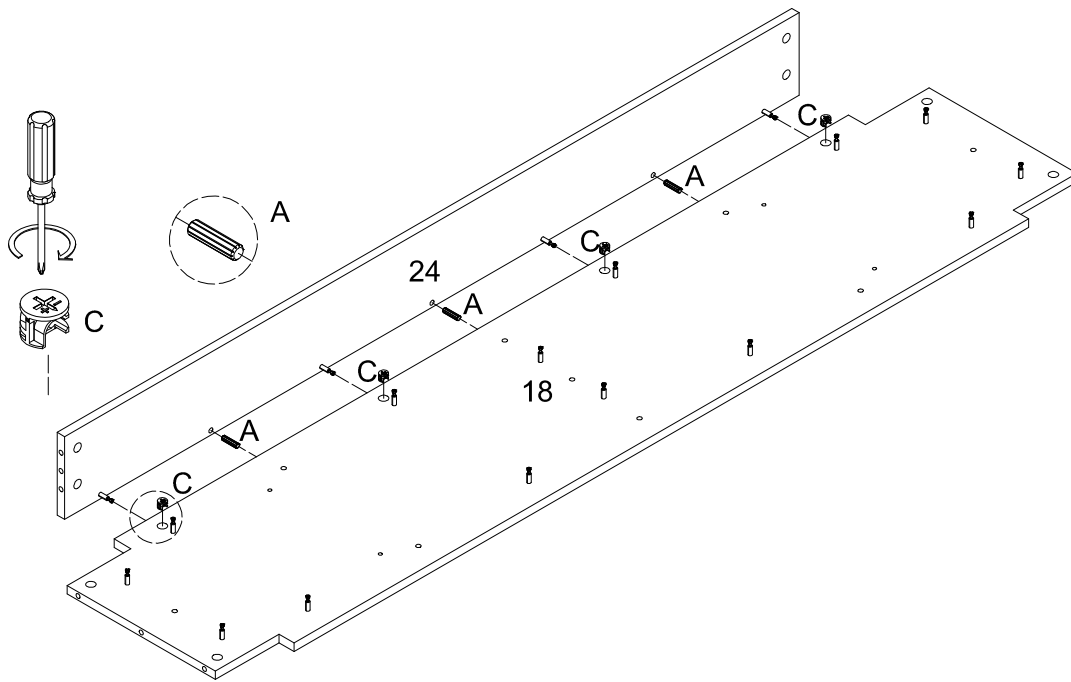

Step 16

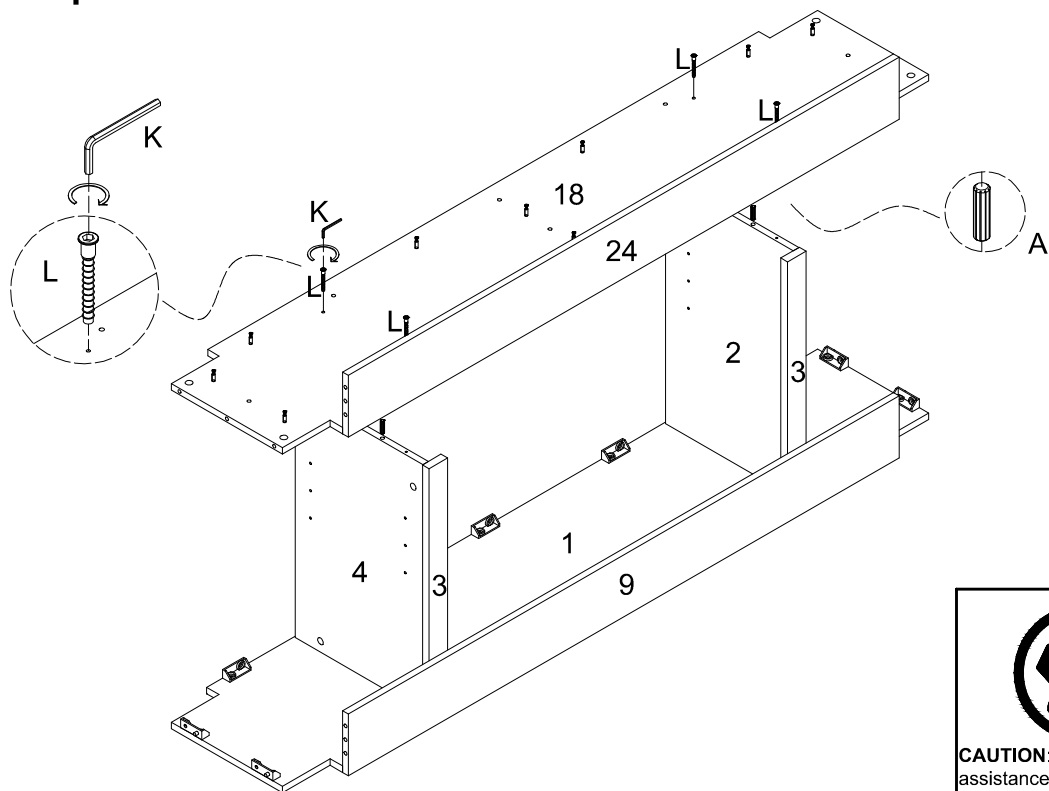

Step 17

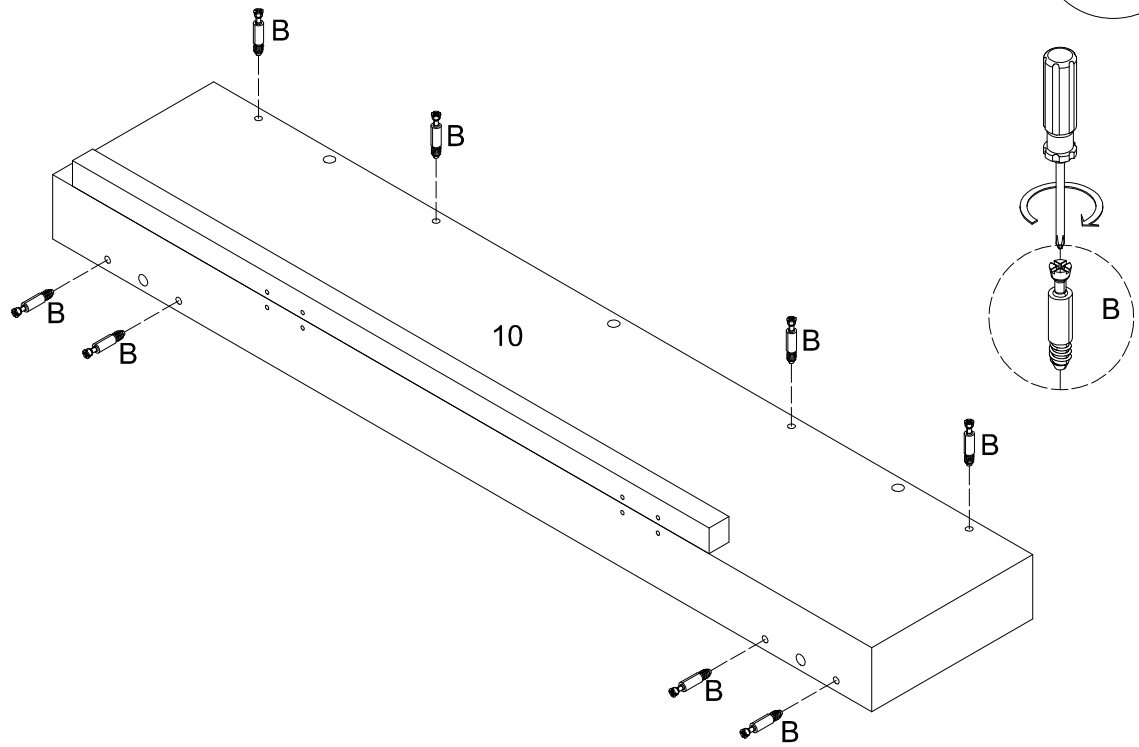

Step 18

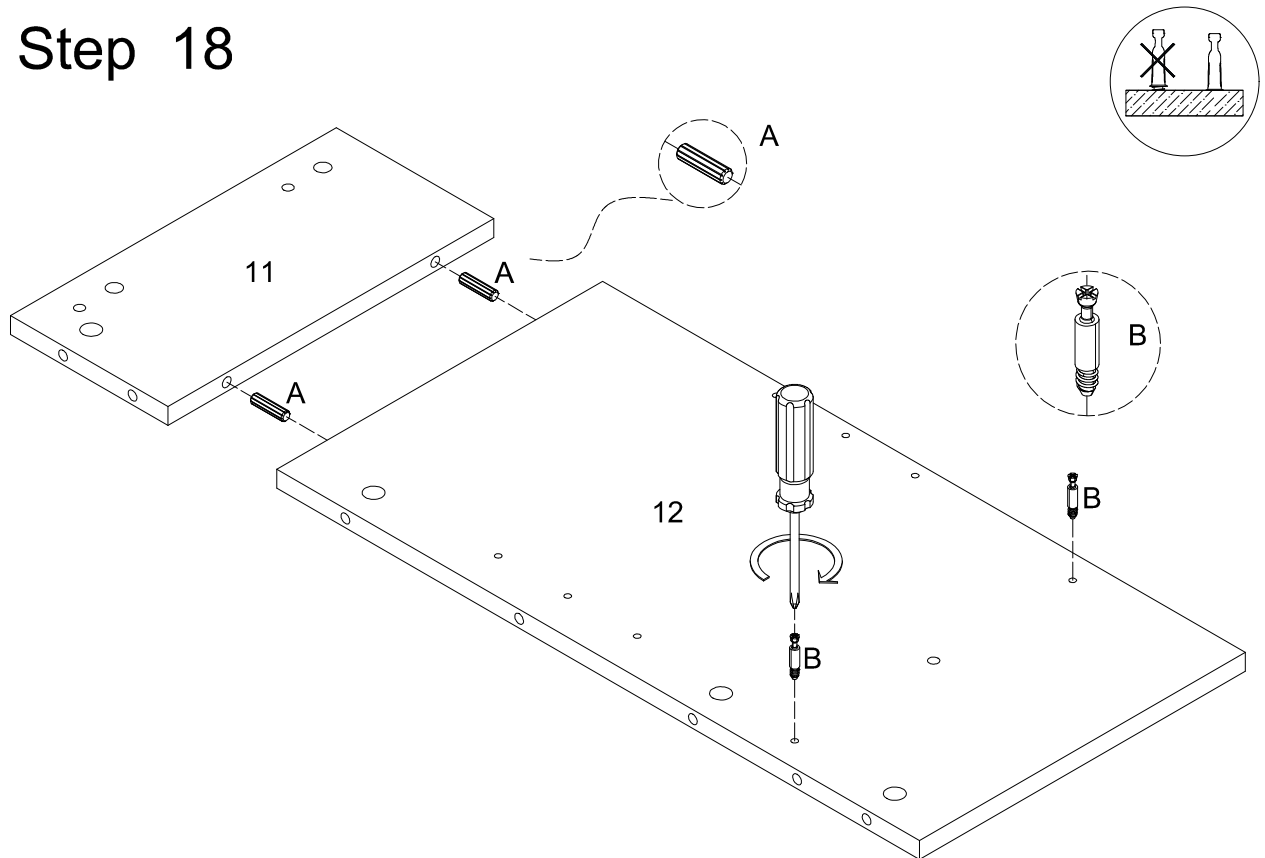

Step 19

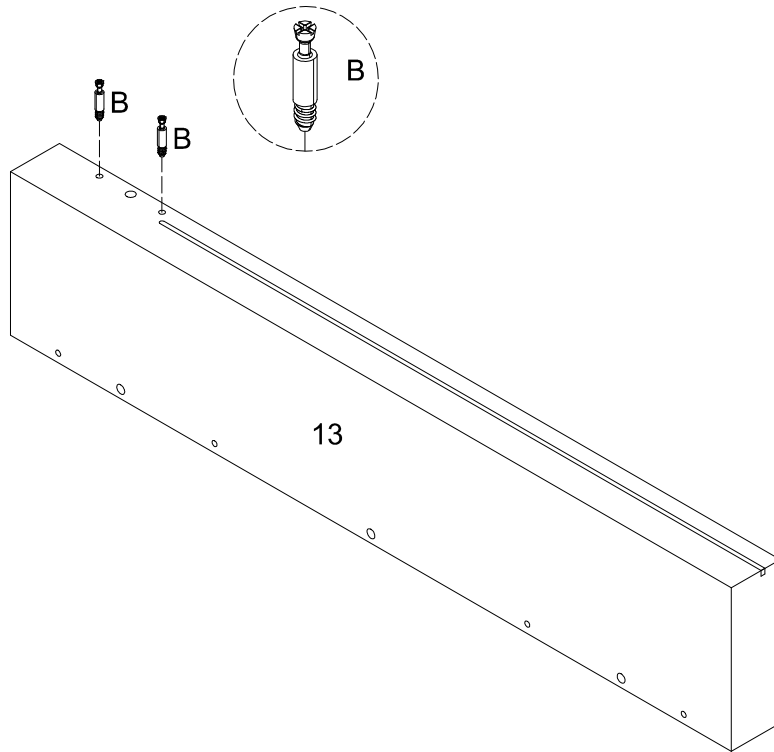
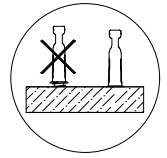

Step 20

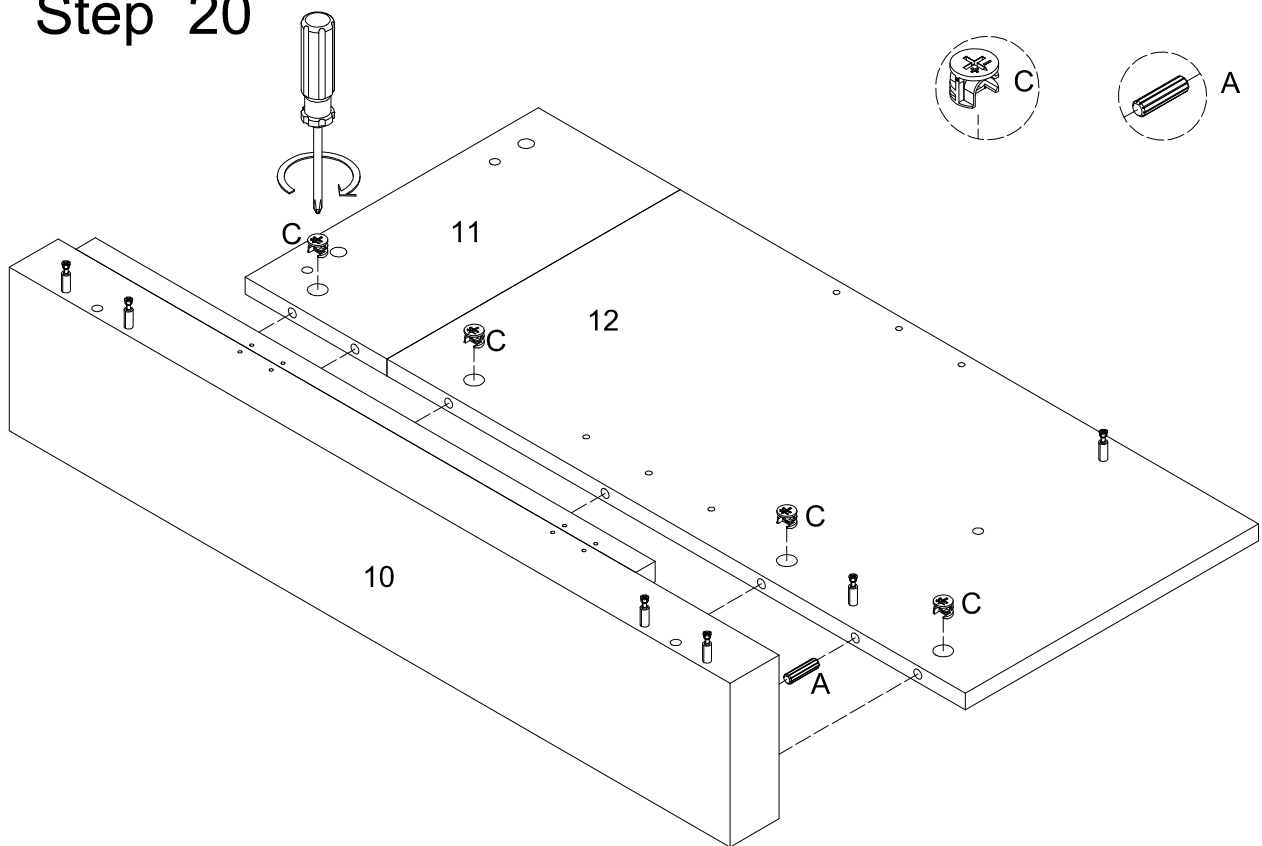
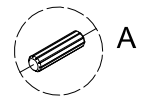

Step 21

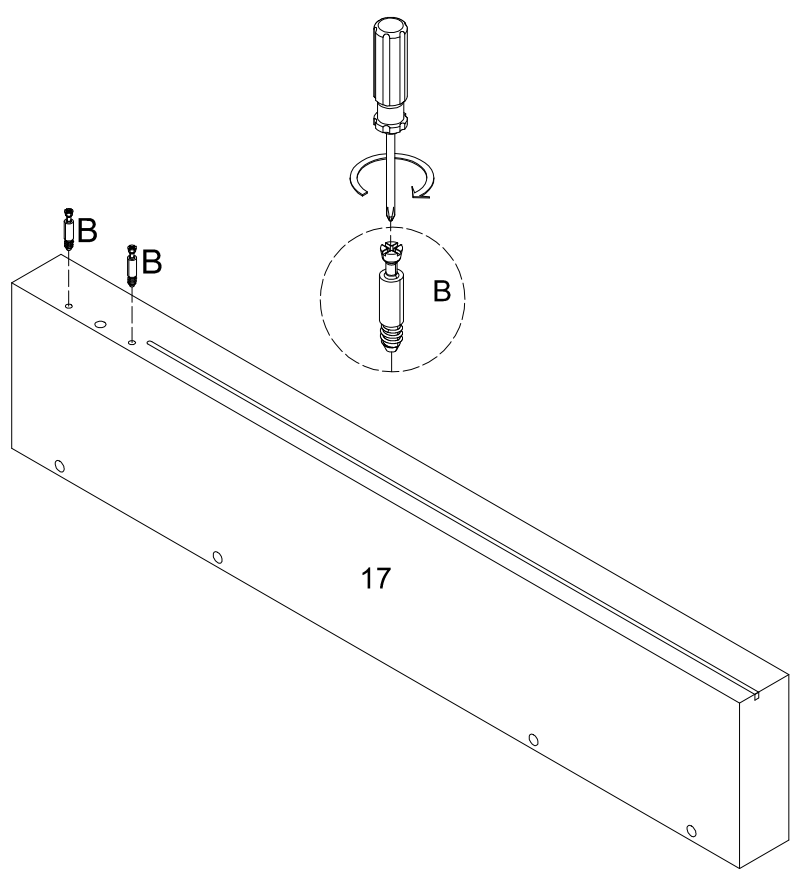

Step 22

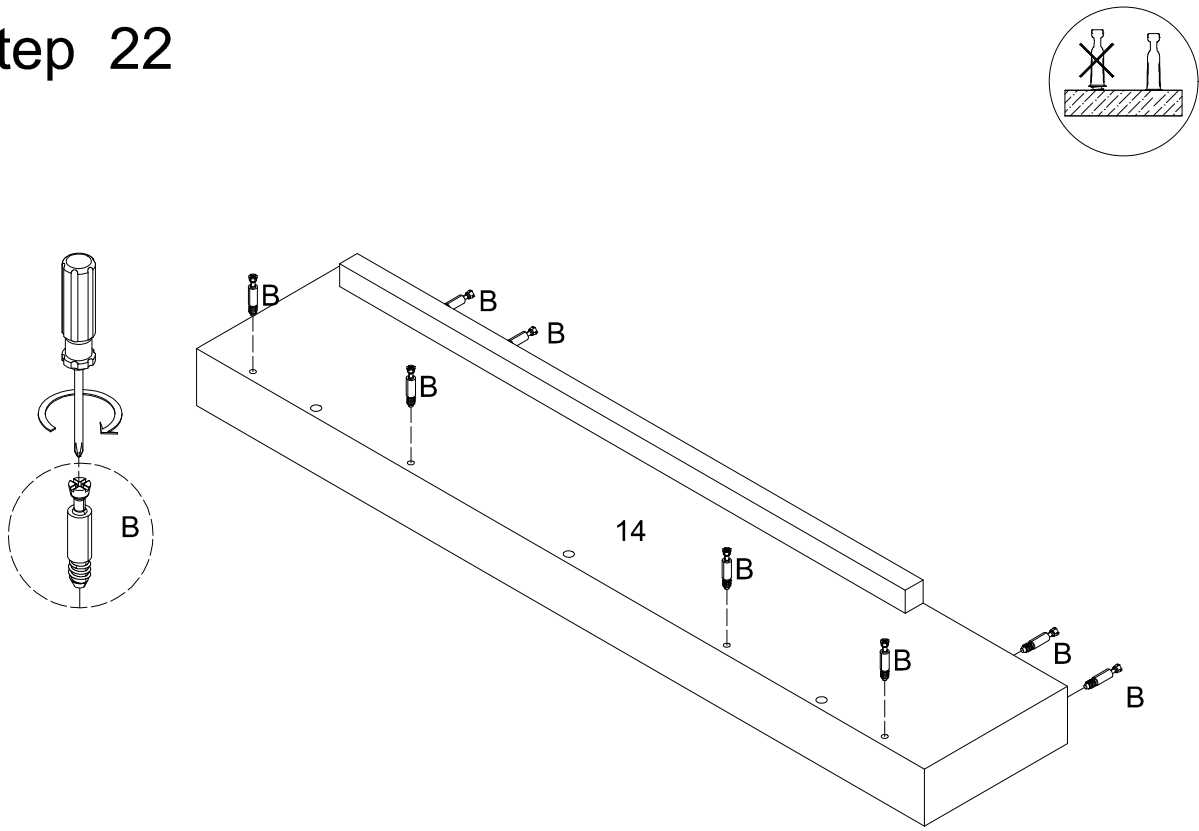

Step 23

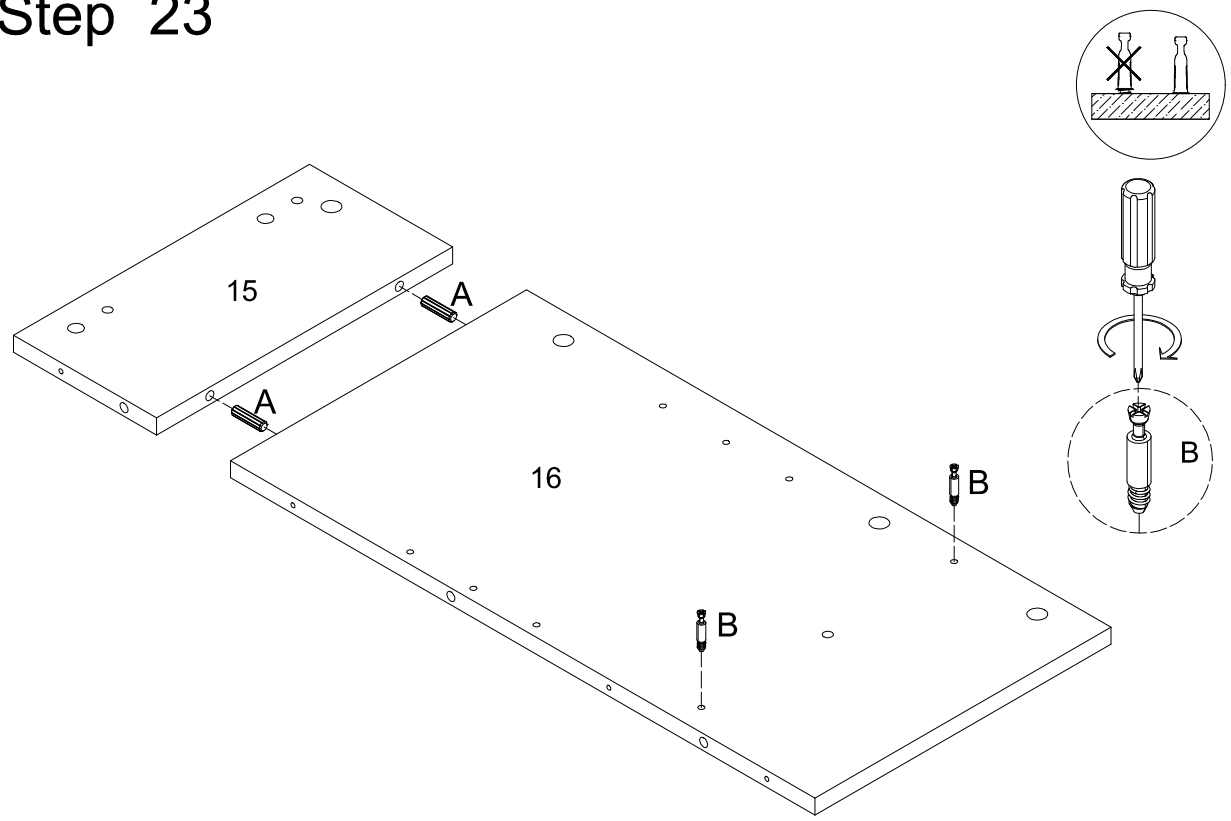

Step 24

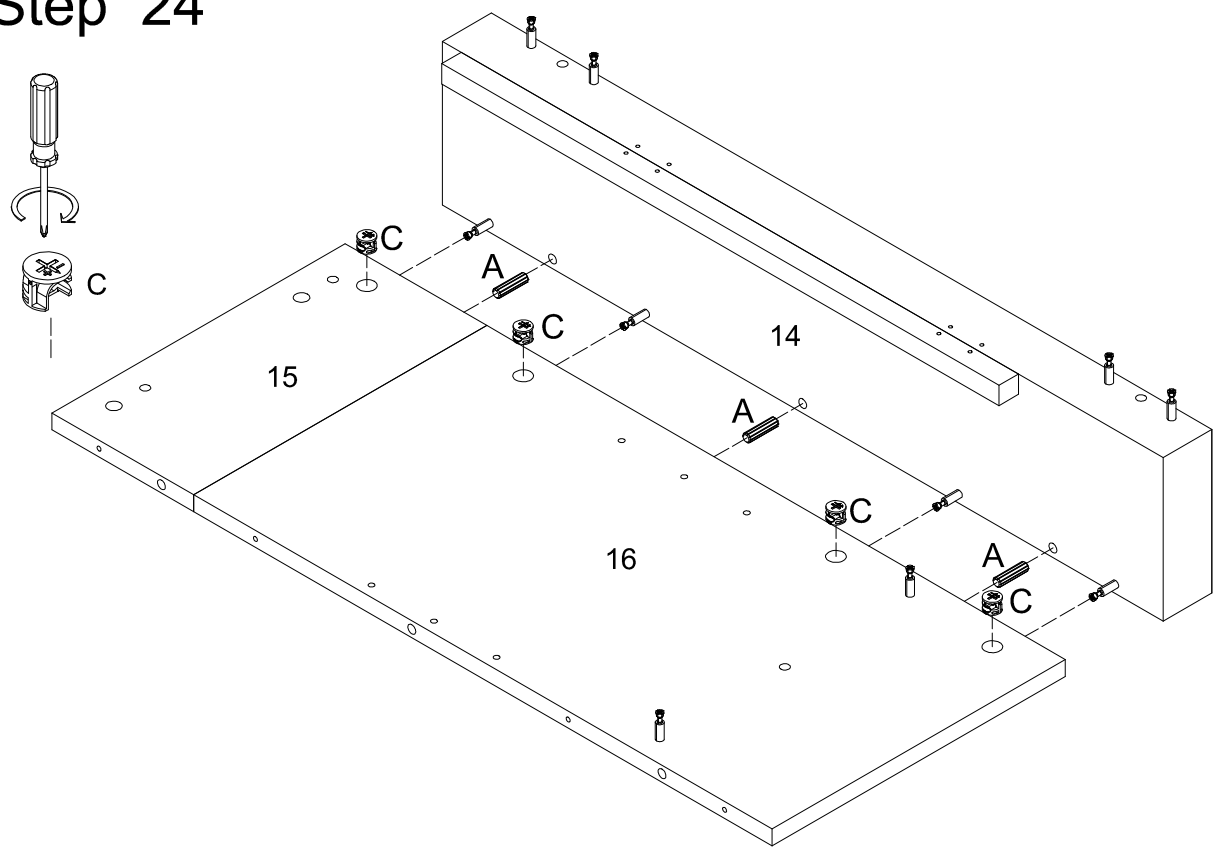

Step 25

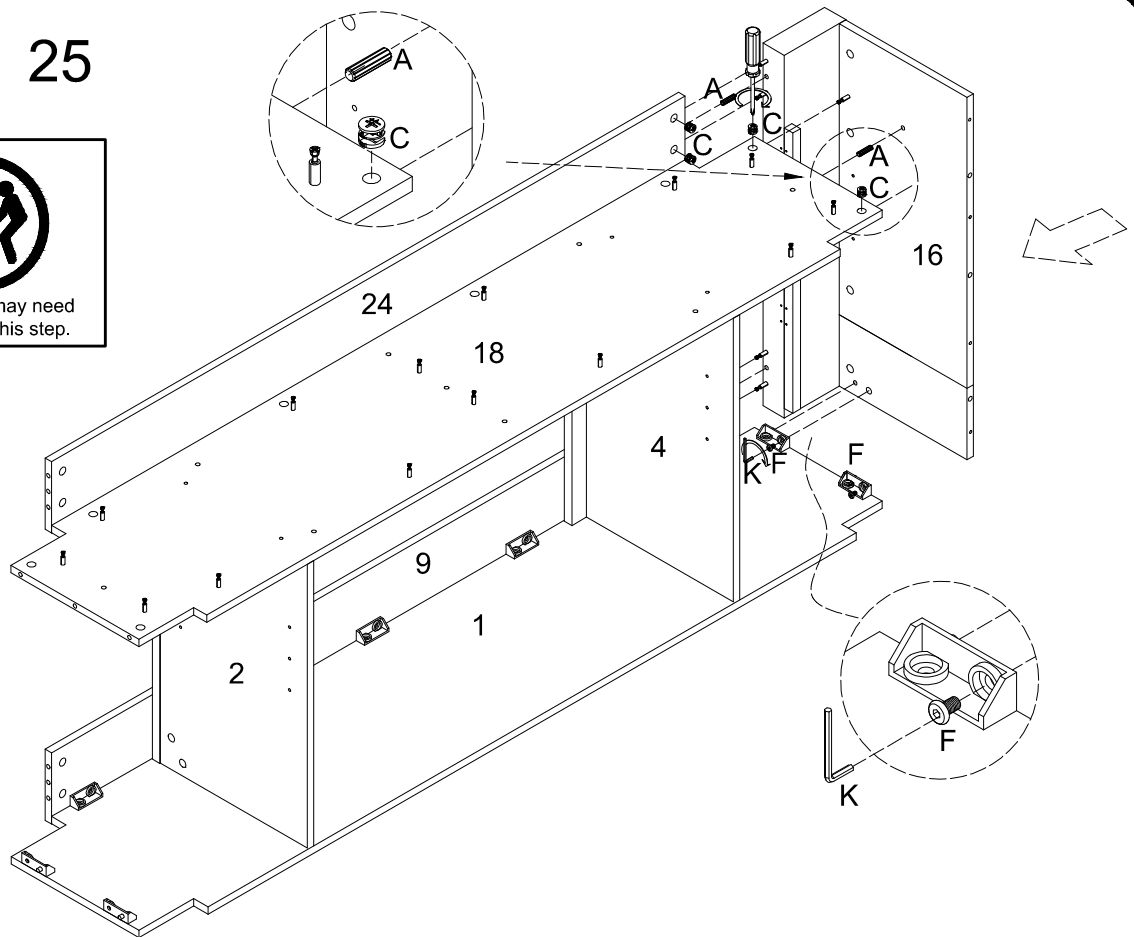

Step 26

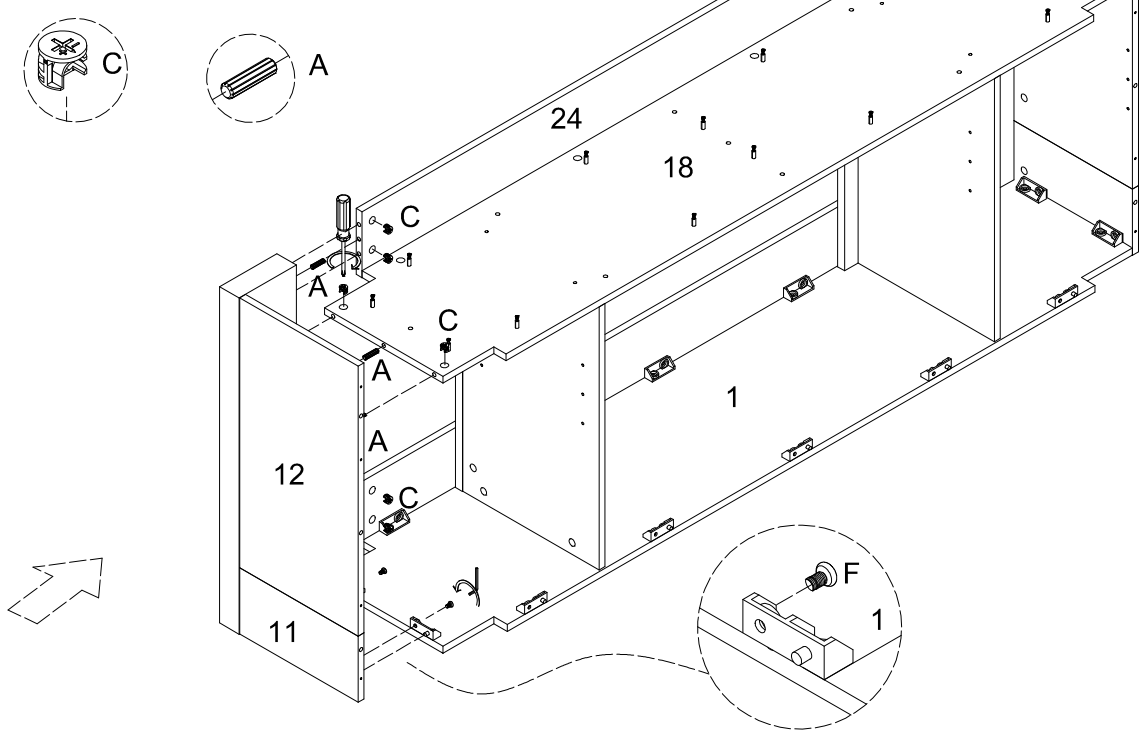

Step 27

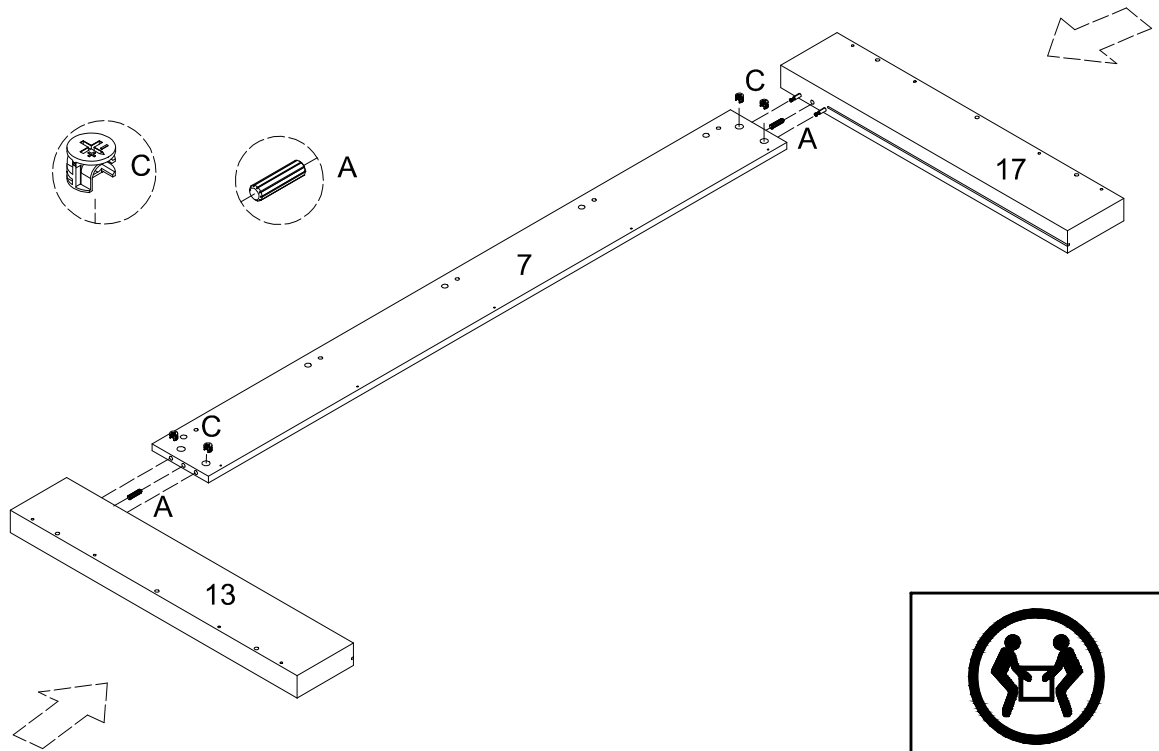

Step 28

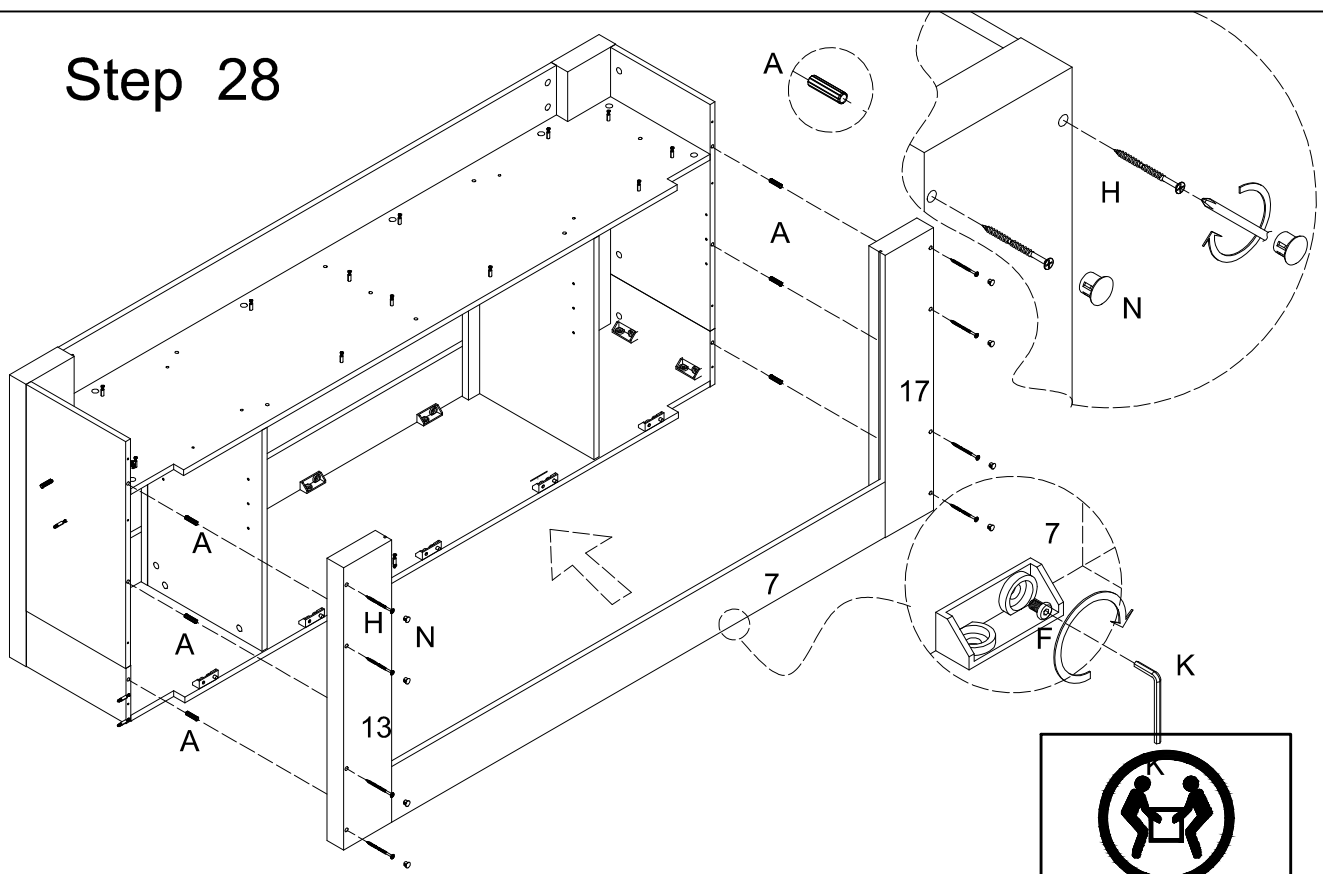

Step 29

Note: Care the direction

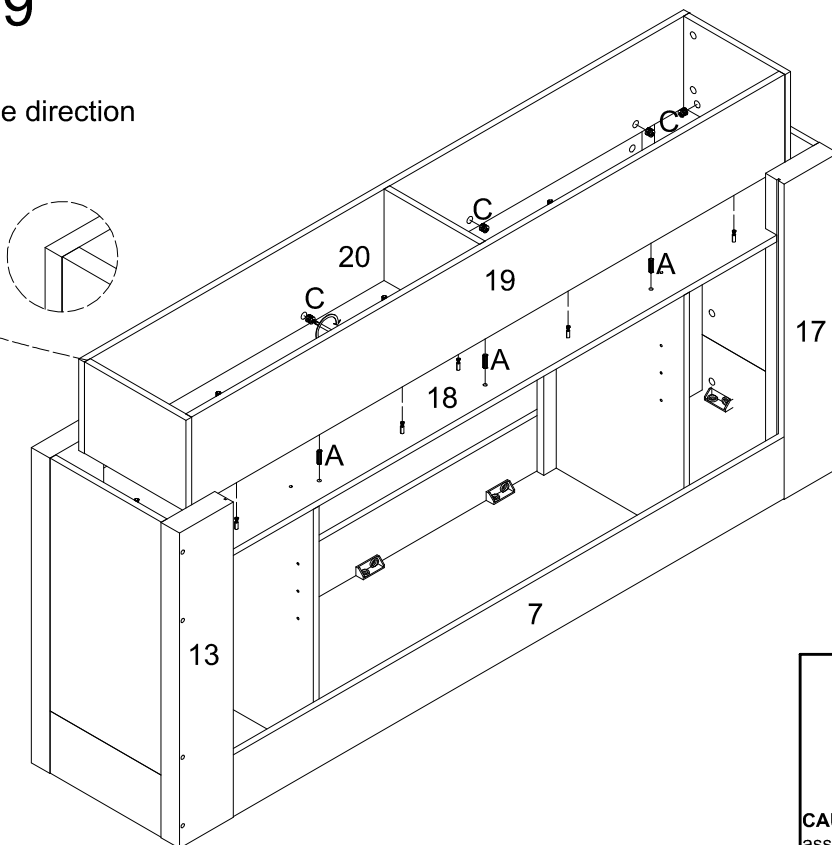

Step 30

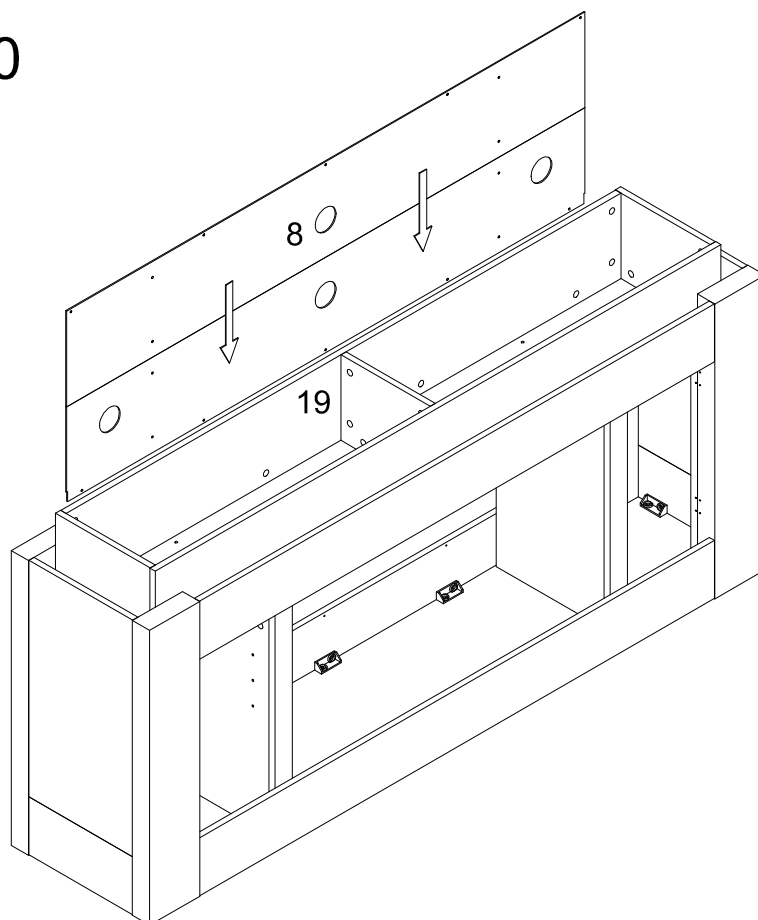

Step 31

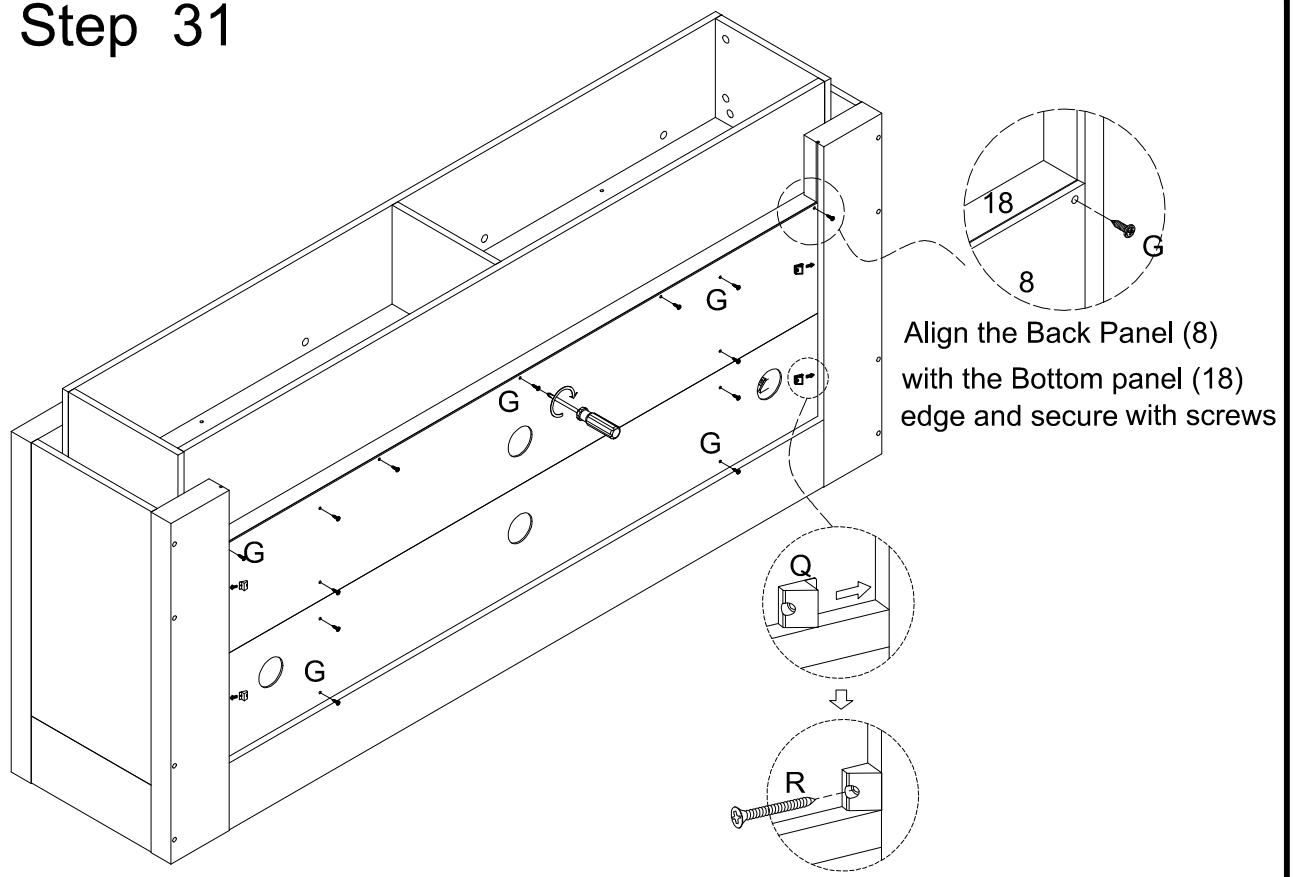

Step 32

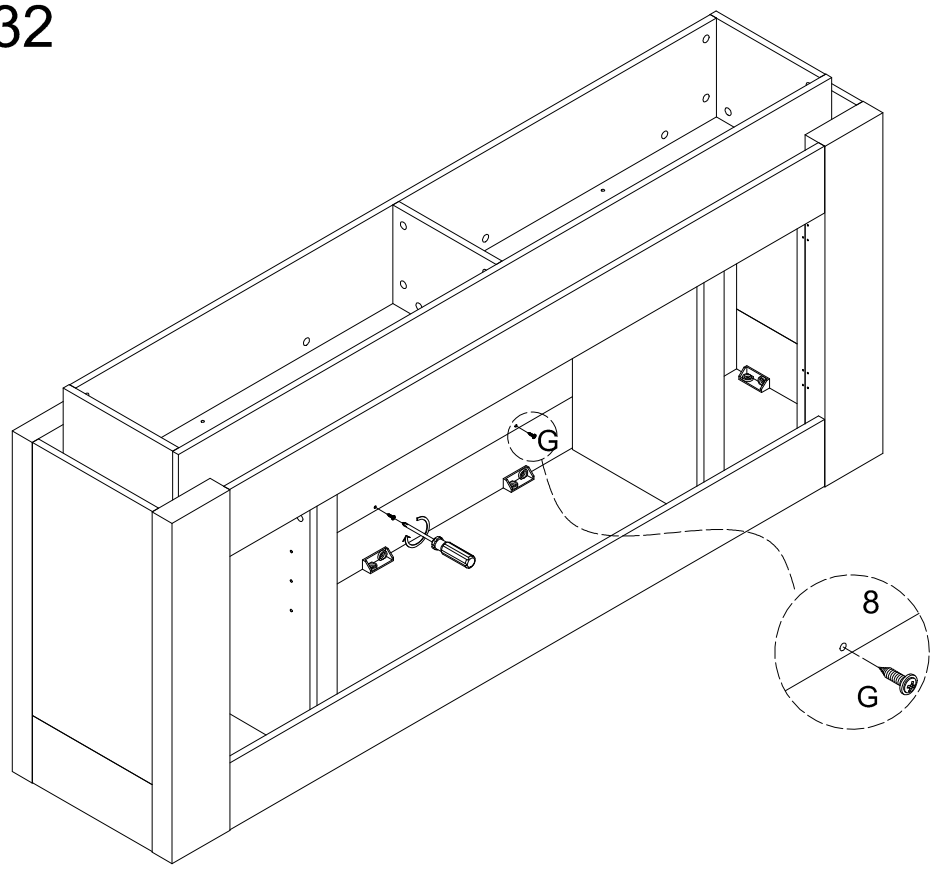

Step 33

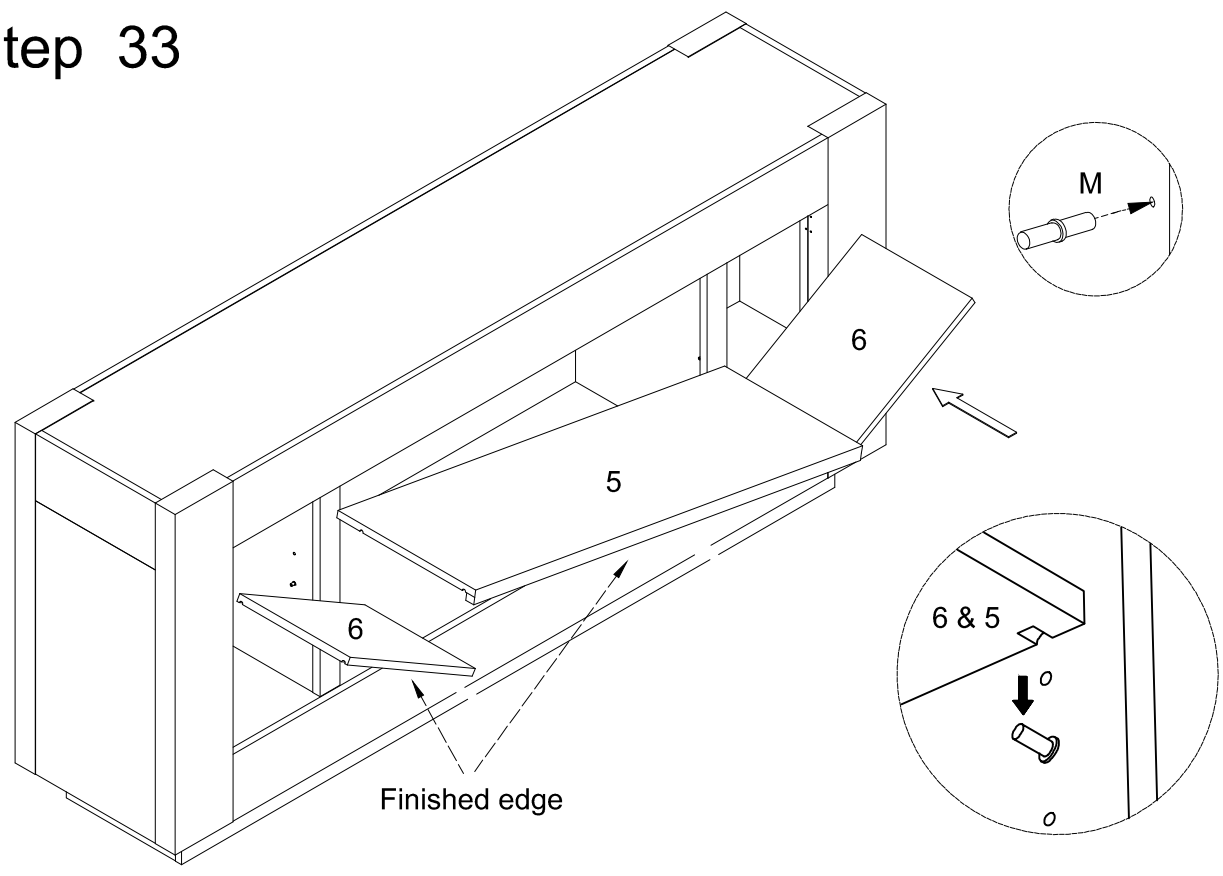

Step 34

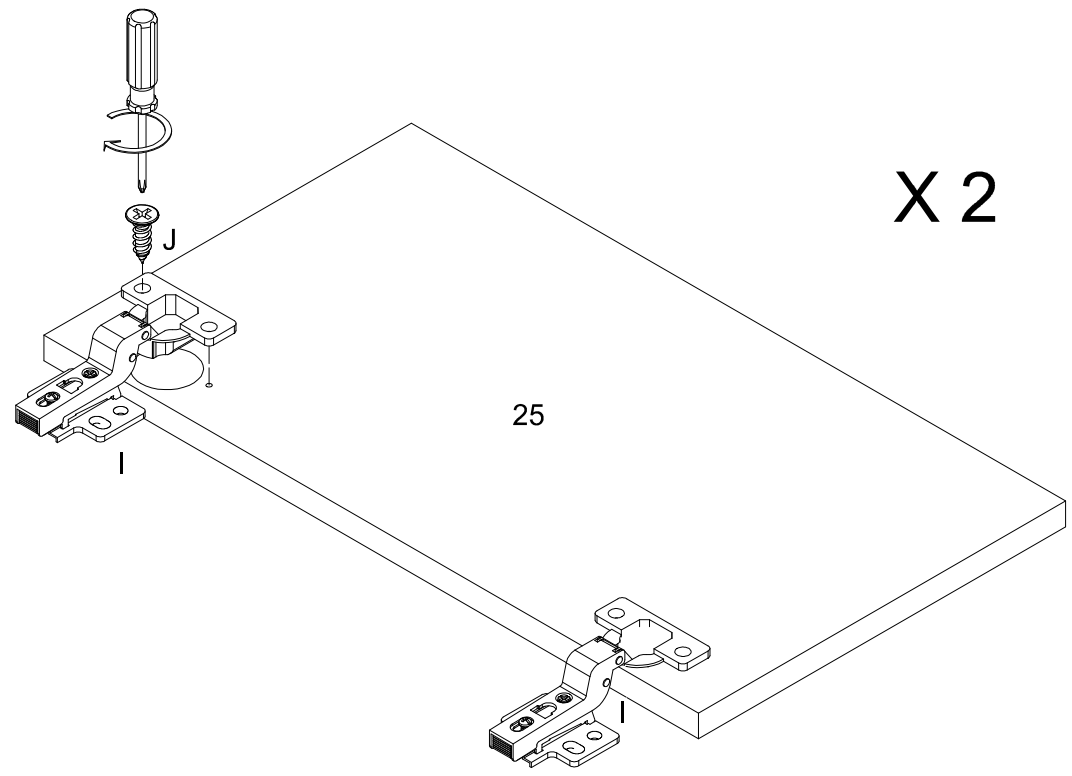

Step 35

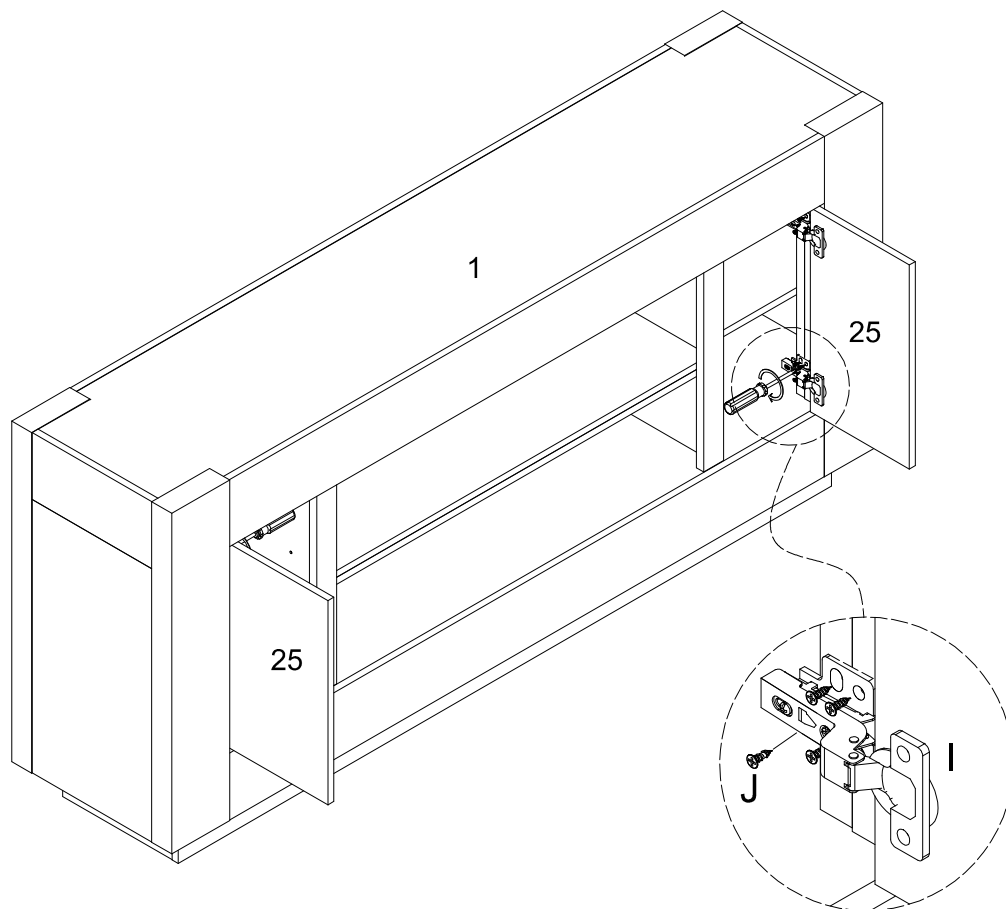

Concealed hinges are three-way adjustable.

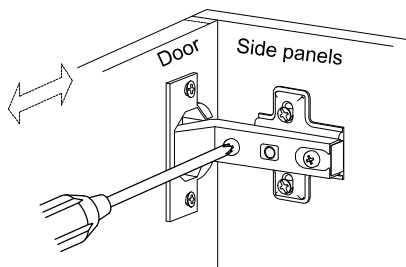

Horizontal
by screw adjustment

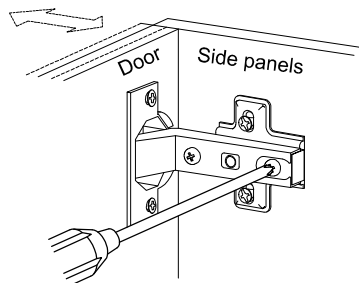

In-and-Out
by loosening the hinge-arm
mounting screw or via cam
adjustment

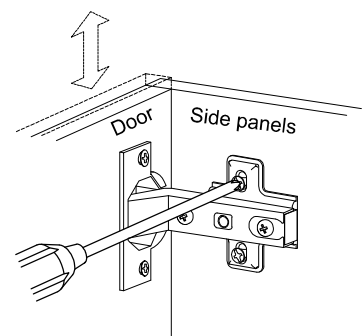

Vertical
Via slots in the mounting
plate or via cam adjustment

Step 36

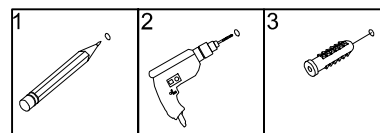

Serious or fatal injuries can occur from furniture tipping over. To prevent the furniture from tipping over we recommend that it is permanently fixed to the wall. Wall anchor and hardware are included with this product. Please make sure hardware is suitable for your walls before installing, as different wall materials may require different types of anchors.

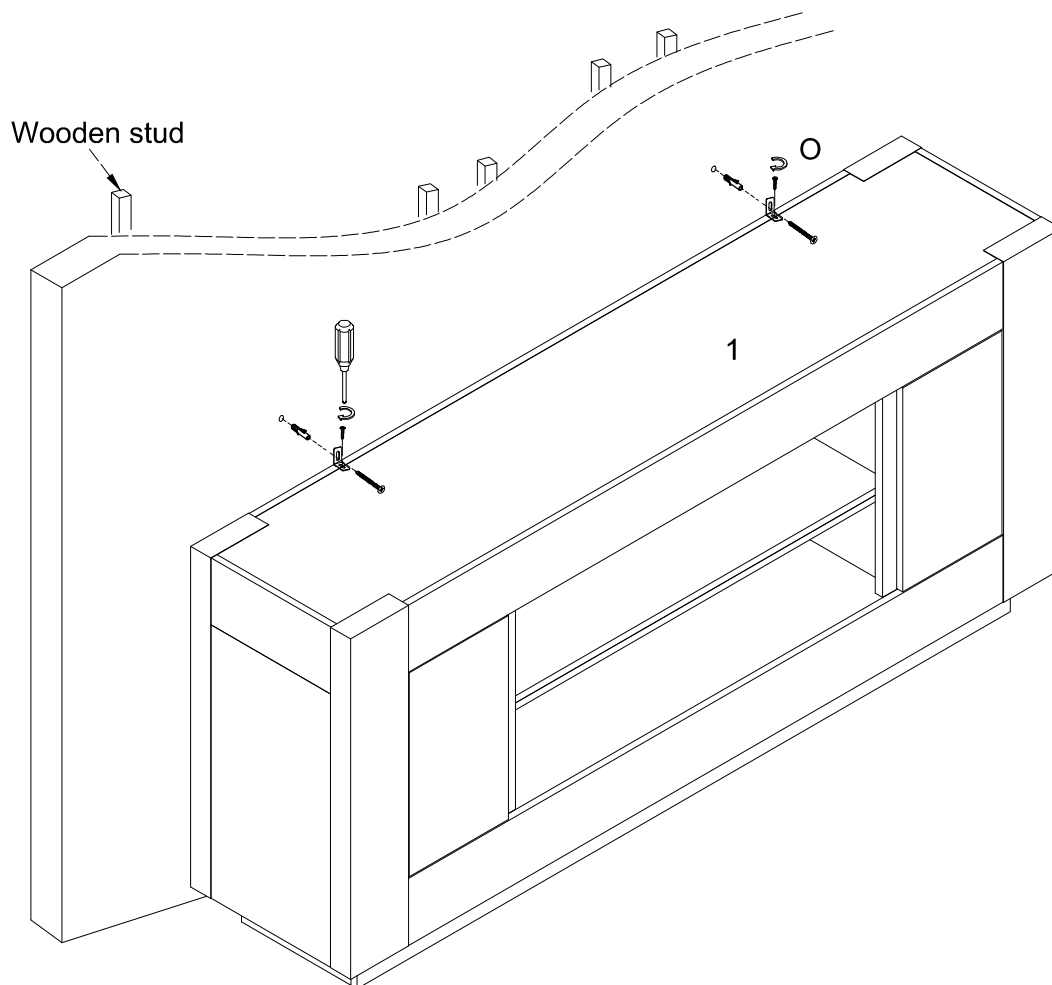
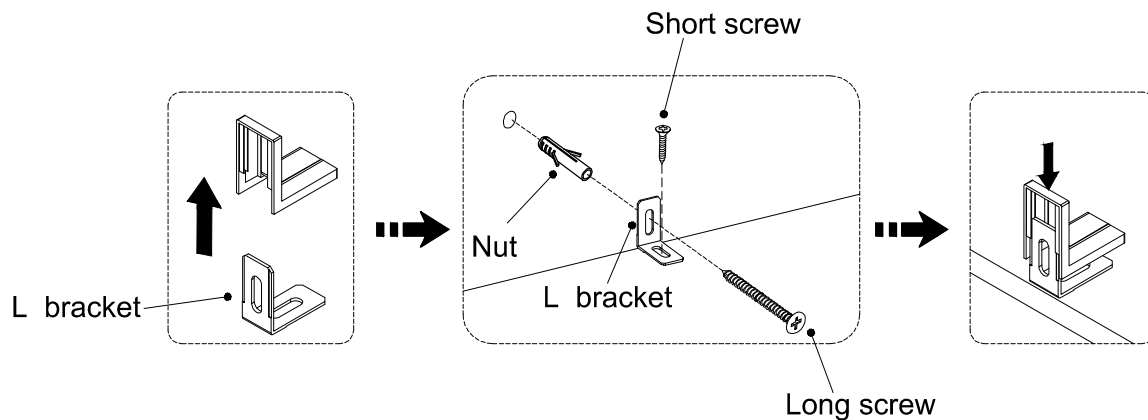

Step 37

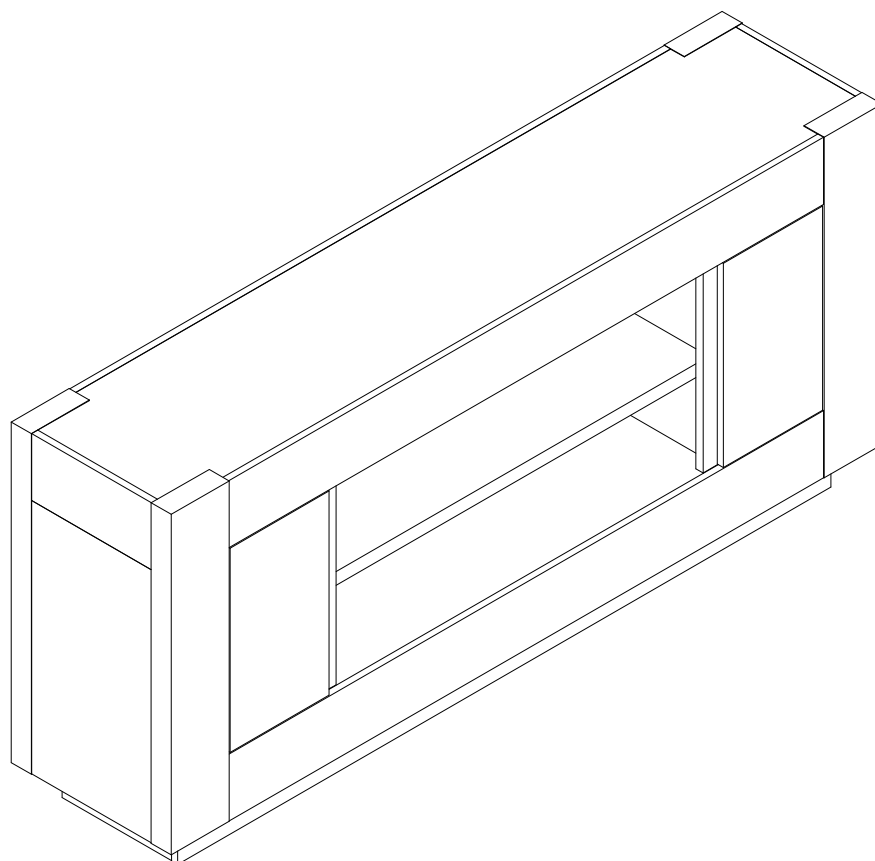

Final Assembly