

ZANUSSI

ZNM PF1601PN/MB

Operating Manual

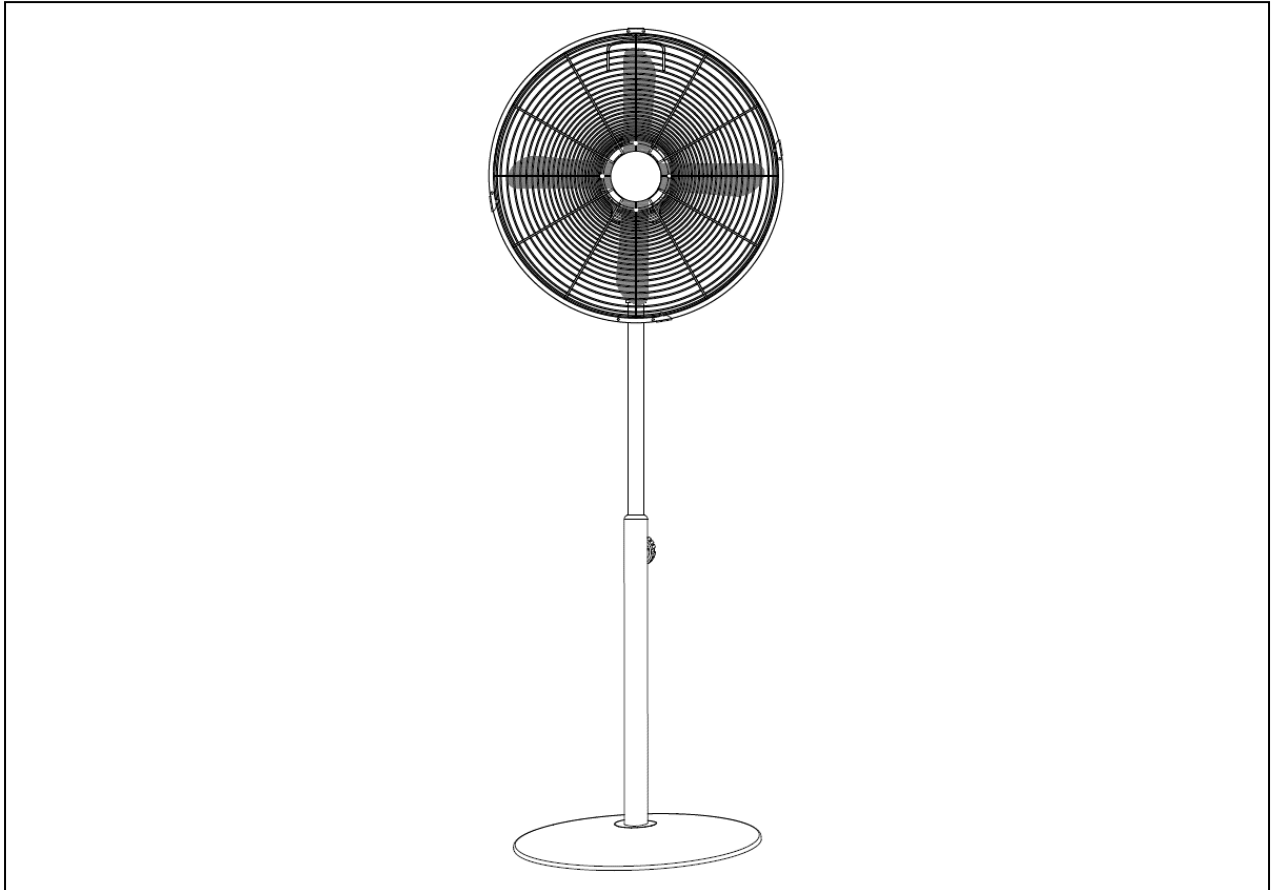

**REGISTER TODAY
FOR YOUR FREE
ADDITIONAL YEAR
GUARANTEE**

GUARANTEE

At Zanussi, we take all our customer feedback seriously.

Feel free to contact our Product Care Team, on **0330 123 0597** who will be more than happy to assist you.

This product is guaranteed for 12 months from the date of the original purchase. If any defect arises due to faulty materials or workmanship, the faulty product must be returned to the place of purchase.

Refund or replacement is at the discretion of the retailer.

The following conditions apply:

- The product must be returned to the retailer with the original proof of purchase.
- The product must be installed and used in accordance with the instructions contained in this instruction guide and any other instructions for use which are supplied.
- It must be used for domestic purposes only and for its intended use.
- This guarantee does not cover wear and tear, damage, misuse or consumable parts.
- This does not affect your statutory rights.

ZANUSSI CONTACT DETAILS

Website: www.zanussiheatingandcooling.uk

Telephone: 0330 123 0597

Address: Product Care, G2S, Green Bank Business Park, Hindley Green, Wigan, WN2 4AY

Note your serial number below for future reference.



Image for illustration purposes only

REGISTER ONLINE

Visit our website to register your full parts and labour guarantee online.

www.zanussiheatingandcooling.uk

REGISTER BY PHONE

Call our friendly Product Care team on the number below.

0330 123 0597

IMPORTANT SAFETY INSTRUCTIONS

- It is hazardous for anyone other than a competent person to carry out any service or repair operation that involves the removal of a cover which gives protection against exposure to electrical parts.
- Do not use with a damaged cord or plug. If the supply cord is damaged, it must be replaced by the manufacturer, its service agent or similarly qualified persons in order to avoid a hazard.
- This product is intended for household use only.
- Do not use outdoors.
- This appliance can be used by children aged from 8 years and above and persons with reduced physical, sensory or mental capabilities or lack of experience and knowledge if they have been given supervision or instruction concerning use of the appliance in a safe way and understand the hazards involved. Children should not play with the appliance. Cleaning and user maintenance should not be made by children without supervision.
- Do not operate this appliance for anything other than its intended use.
- Do not immerse whole unit in water or other liquids for cleaning.
- Unplug from outlet when not in use. Do not leave unattended while plugged in.
- Do not use if it has been dropped, damaged, left outdoors or dropped into water.
- Keep the appliance away from water; do not allow it to get wet. If unit is wet, do not plug unit into wall socket or turn unit on.
- Do not handle the appliance with wet hands.
- Do not pull or carry by cord, use cord as a handle, close door on cord, pull cord around sharp corners or edges, or expose cord to heated surfaces. Do not unplug by pulling on cord.
- To protect against electrical shock do not immerse cord, plug, or appliance in water or other liquid.
- Unplug from the mains outlet when not in use, before putting on and taking off parts, and before cleaning.
- Only use the unit when fully assembled.
- Never place your fingers or other objects into any part of the appliance. Be aware that loose clothing or hair may become trapped in the appliance if improperly used.
- Before use, ensure that all of the air vents of the appliance are clear and there is no restriction of air flow.
- Caution: Appliance may disturb ashes in an open fire. Always avoid directing the appliance toward naked flames.

The 'wheelie bin' symbol is known as the 'Crossed-out wheelie bin Symbol'. When this symbol is marked on a product/batteries, it means that the product/batteries should not be disposed of with your general household waste. Only discard electrical/electronic/battery items in separate collection schemes, which cater for the recovery and recycling of materials contained within. Your co-operation is vital to ensure the success of these schemes and for the protection of the environment. For your nearest disposal facility, visit www.recycle-more.co.uk or ask in store for details.

We reserve the right, due to possible changes to design, to alter the instruction manual without prior notice.

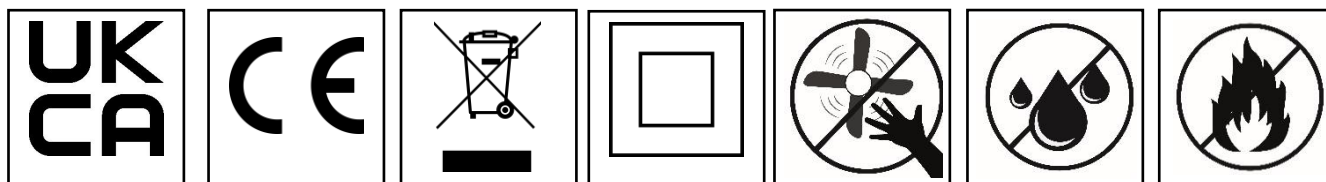

PARTS

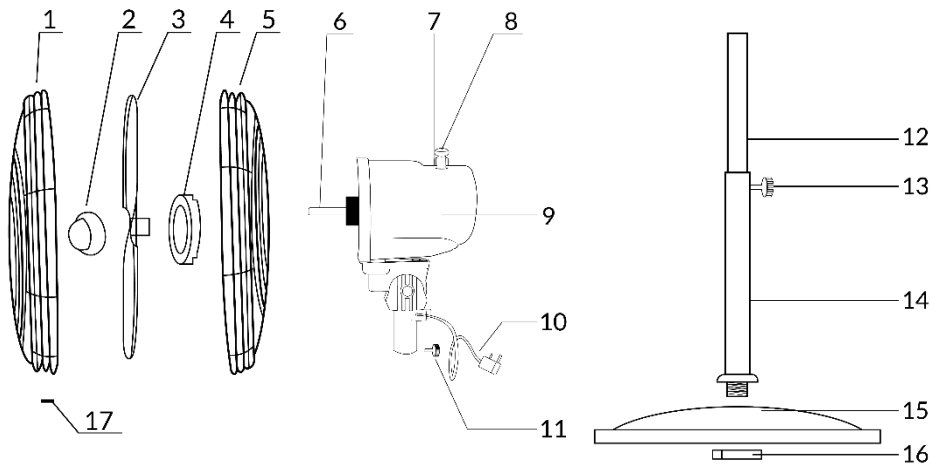

1. Front Grille
2. Fan Blade Securing Cap
3. Fan Blade
4. Rear Grille Securing Nut
5. Rear Grille
6. Fan Blade Fixing Point
7. Speed Adjustment Dial
8. Oscillation Switch
9. Motor Housing
10. Power Cord & Plug
11. Housing Fixing Screw
12. Extension Pole
13. Extension Screw
14. Lower Pole
15. Fan Base Plate
16. Base Plate Securing Nut
17. Grille Securing Screw

ASSEMBLY

1. Thread the Lower Pole [14] through the Base Plate [15] and secure with the Nut [16]
2. Attach Motor Housing [9] onto Extension Pole [12] and secure with Fixing Screw [11]
3. Place Rear Grille [5] on Motor Housing [9] aligning with rear posts, and secure with Nut [4]
4. Attach Fan Blade [3] onto Fixing Point [6] and secure with Cap [2]
5. Clip Front Grille [1] onto Rear Grille [5] using attached clips, and screw in Securing Screw [17]. Screw Hole on the Front Grille should be on the bottom.

SETTINGS

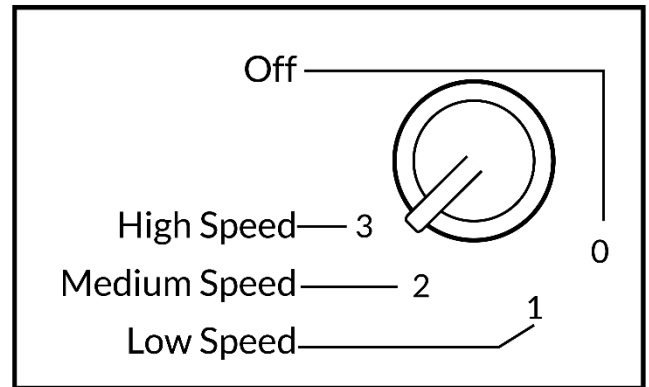

OSCILLATION

Press the switch on the rear of the fan to engage the oscillation feature.

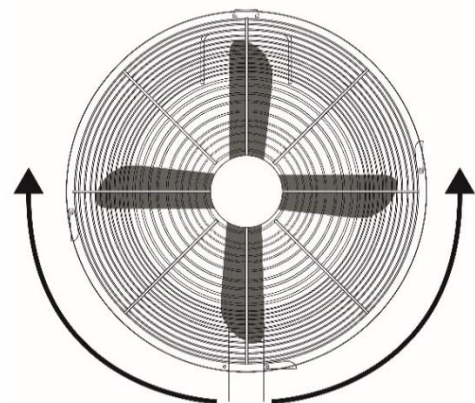
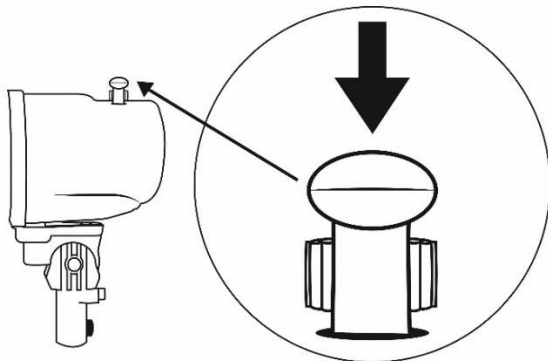

PROBLEM SOLVING

The fan doesn't switch on	<ul style="list-style-type: none">• Check the fan is plugged in• Check the socket is switched on• Check another appliance in the socket• Unplug and check for any obvious signs of damage to cord or plug• If recently used, allow to cool for 1 hour then try again
The fan is rattling	<ul style="list-style-type: none">• Check the grille is secured properly• Check all screws are securely fastened• Check there is nothing in contact with the fan
Fan will not oscillate	<ul style="list-style-type: none">• Check the oscillation switch is pressed down• Check that nothing is interfering with the fan preventing oscillation
Fan is making a grinding sound	<ul style="list-style-type: none">• Immediately switch off and contact Product Care
The air is dusty	<ul style="list-style-type: none">• Ensure fan is unplugged and set to 0• Carefully remove grille• Carefully remove blades from fan• Using mild soapy water and a sponge, gently rinse the blades• Allow to dry naturally for 24 hours then refit the blades

If you are still experiencing difficulties with the appliance please contact us **BEFORE** returning the appliance to the retailer it was purchased from:

Website: <https://www.zanussiheatingandcooling.uk>

Telephone: 0330 123 0597

Address: Product Care, G2S, Green Bank Business Park, Hindley Green, Wigan, WN2 4AY

IMPORTANT!

KEEP BLADES CLEAN

Wash the blades with cold water at least once every 3 months.
The blades may require more frequent washing if in a dusty environment.

3

MONTHS

ZANUSSI

This product is guaranteed for 12 months from the date of the original purchase. If any defect arises due to faulty materials or workmanship, the faulty product must be returned to the place of purchase.

By registering your product you will get an additional year guarantee free of charge.

REGISTER ONLINE

Visit our website to register your full parts and labour guarantee online.

www.zanussiheatingandcooling.uk

REGISTER BY PHONE

Call our friendly Product Care team on the number below.

0330 123 0597

NOTES

**REGISTER YOUR FREE
ADDITIONAL YEAR
GUARANTEE TODAY**

www.zanussiheatingandcooling.co.uk
Product Care, G2S Ltd, Green Bank Business Park,
Swan Lane, Hindley Green, Wigan, WN2 4AY

ZANUSSI

ZANUSSI is a registered trademark used under license from AB Electrolux (publ). Made under license by Product Care Trading Limited, Wigan, WN2 4AY/ PCT (NI) Ltd, Belfast, BT5 5AD

Zanussi Support: call 0330 123 0597 or visit

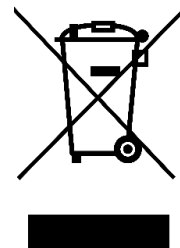
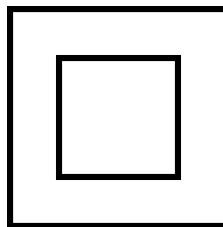

The 'wheelie bin' symbol is known as the 'Crossed-out wheelie bin Symbol'. When this symbol is marked on a product/batteries, it means that the product/batteries should not be disposed of with your general household waste. Only discard electrical/electronic/battery items in separate collection schemes, which cater for the recovery and recycling of materials contained within. Your co-operation is vital to ensure the success of these schemes and for the protection of the environment. For your nearest disposal facility, visit www.recycle-more.co.uk or ask in store for details.

SEDEX – Connecting businesses and their global suppliers to share ethical data and enabling improvement in ethical performance. Visit www.sedex.org.uk for further information.

We reserve the right, due to possible changes to design, to alter the instruction manual without prior notice.