

PACKAGE CONTENTS

INCANDESCENT CYLINDER CORD MOUNT

PART	DESCRIPTION	QUANTITY
A	Fixture	1
B	Coupling nut	1
C	Canopy	1
D	Plastic screw	1
E	Mounting strap	1
F	Plastic wire clip	1

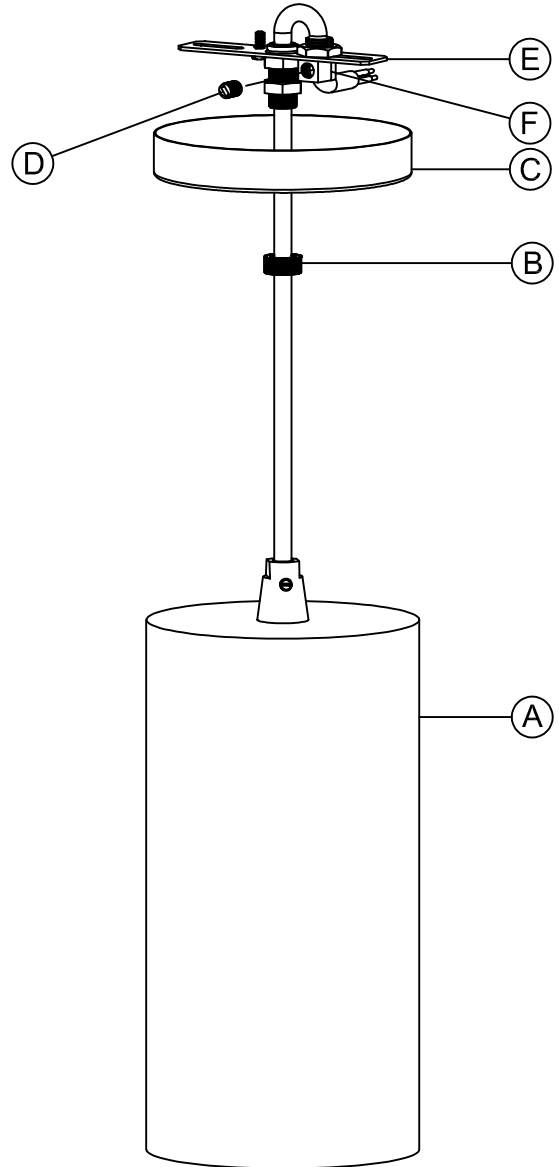

ATTACH YOUR RECEIPT HERE

Purchase Date _____

HARDWARE CONTENTS (not actual size)

AA

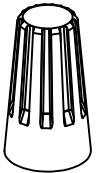

Wire nut

Qty:3



Safety Information

Please read and understand this entire manual before attempting to assemble, operate or install the product.

CAUTION: Read instructions carefully and turn electricity off at main circuit breaker panel before beginning installation.

CAUTION: Risk of fire. Min. 90°C supply conductors. Consult a qualified electrician to ensure correct branch circuit conductor.

WARNING: If any Special Control Devices are used with this fixture, follow instructions carefully to assure full compliance with N.E.C. requirements. If there are any questions, contact a qualified electrical contractor.

CAUTION: All glass is fragile. Use care when handling glass shades and bulbs.

WARNING - To comply with the National Electrical Code and Underwriters Laboratories requirements, only use indoor or damp location.

Proper replacement of a part removed for user maintenance.

Assembly instructions for a luminaire that requires partial assembly in the field

Preparation

1. Before beginning installation, make sure all parts are included using the contents diagrams from page 1. If any part is missing or damaged, do not attempt to assemble, install or operate the product.

2. Estimated assembly time: 30 minutes.

3. Tools required for assembly (not included): Phillips screwdriver, pliers, wire stripper, safety glasses, electrical tape, ladder.

Care and Maintenance

Shut off main power supply before cleaning product or changing light bulbs. To clean, wipe with damp cloth. Do not use abrasive cleaners or cleaners that contain alcohol.

Assembly Instructions

1

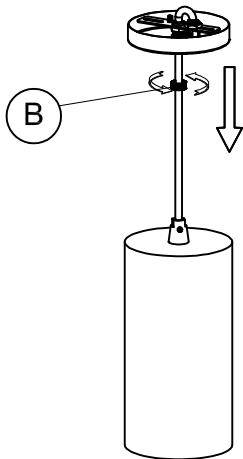

1. Loosen coupling nut(B) and move down the canopy.

(B) Coupling nut



X1

2

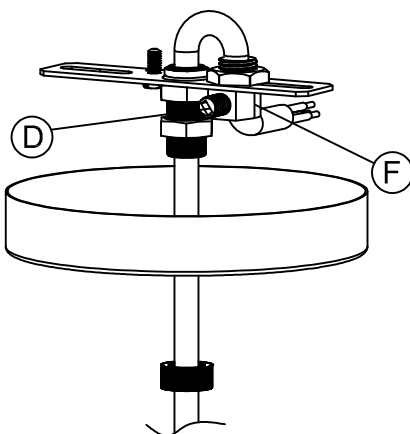

2. Loosen plastic screw (D) and slide the cord through wire clip (F) to desired length, tighten the plastic screw (D) back and cut additional cord. Keep cord minimum 6" beyond the wire clip. Remove cord jacket about 1" from the cord end.

(D) Plastic screw



X1

(F) Plastic wire clip



X1

Assembly Instructions

3

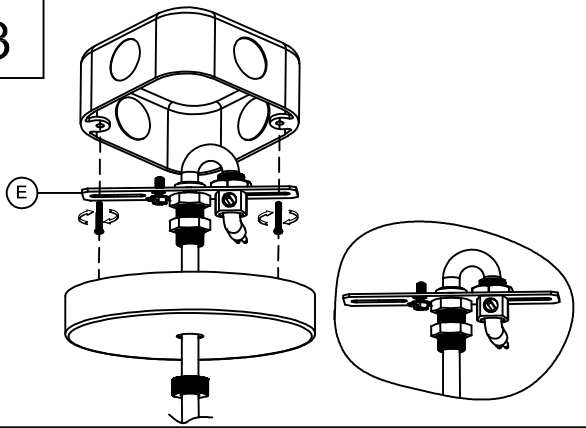

3. Attach mounting strap (E) to the outlet box using the mounting screws supplied with the outlet box (not included).

(E) Mounting strap  X1

4

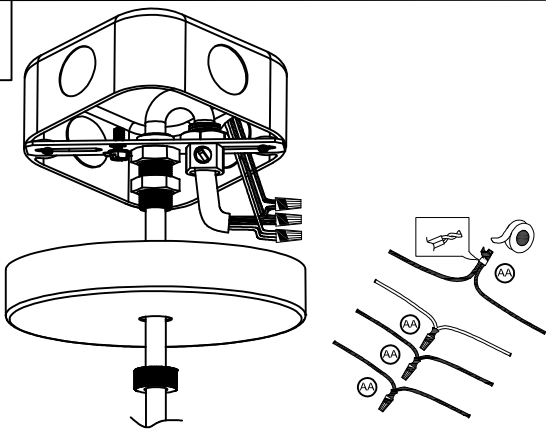

4. Strip 3/8" of insulation from the electrical wire ends. Using wire nuts (AA), connect WHITE fixture wire to the WHITE supply wire from the junction box, connect the BLACK fixture wire to the BLACK supply wire, connect the GREEN fixture ground wire to the supply ground wire. Push all wire connections into the junction box.

(AA) Wire nut  X3

5

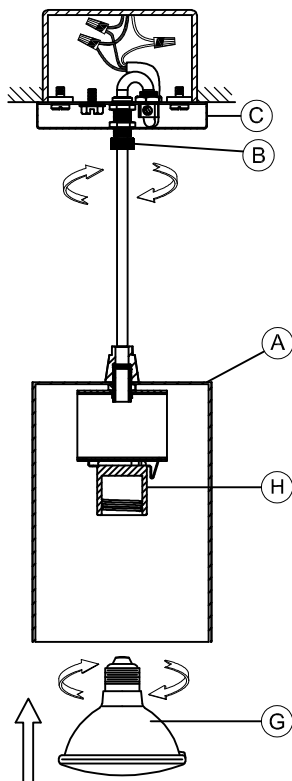

5. Move the canopy (C) up to the junction box and tighten the coupling nut (B). Install the incandescent lamp (G) (not included) to the socket (H).

Use MAX 65 WATTS, TYPE BR30 Incandescent, MAX 75 WATTS, TYPE PAR30 or A19 Incandescent or equivalent SBCFL or SBLED for P500355.

Use MAX 250 WATTS, TYPE PAR38 Halogen or MAX 100 WATTS, TYPE A19 Incandescent or MAX 75 WATTS, TYPE PAR30 or equivalent SBCFL or SBLED for P500356.

(C) Canopy  X1

(B) Coupling nut  X1

Instrucciones de ensamblaje e instalación

Precaución: Lea cuidadosamente las instrucciones y desconecte la electricidad del cortacircuitos principal antes de iniciar la instalación.

PRECAUCIÓN: Lea cuidadosamente las instrucciones y desconecte la electricidad del cortacircuitos principal antes de iniciar la instalación.

PRECAUCIÓN: Riesgo de fuego. Min. 90°C los cables de suministro. Consulte a un electricista calificado para asegurarse de que el conductor del circuito derivado correcto.

ADVERTENCIA: Si usa algún dispositivo especial de control con este aparato de luz, siga las instrucciones cuidadosamente para asegurar la completa conformidad con los requisitos N.E.C. Si existe alguna duda, contacte un electricista calificado.

PRECAUCION: El vidrio es frágil; tenga cuidado al manipular el (los) elemento(s) de vidrio y/o la(s) bombilla(s).

ADVERTENCIA: Para cumplir con los requisitos del National Electrical Code y Underwriters Laboratories, solo use lugares interiores o húmedos.

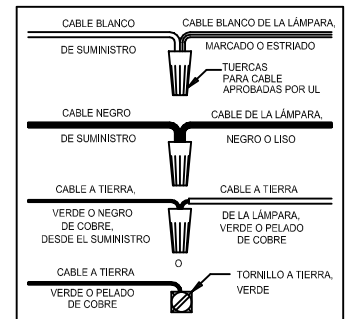

Instructions d'Assemblage et Installation

Mise en garde: Lire les instructions avec soin et couper le courant au disjoncteur central avant de commencer l'installation.

MISE EN GARDE: Lire les instructions avec soin et couper le courant au disjoncteur central avant de commencer l'installation.
MISE EN GARDE: Risque d'incendie. Min 90°C conducteurs d'alimentation. Consulter un électricien qualifié pour assurer le bon conducteur de circuit de dérivation.

AVERTISSEMENT: S'il y a d'autres mécanismes régulateurs qui s'emploient avec ce dispositif, suivre soigneusement les instructions pour satisfaire aux exigences NEC. Si vous avez des questions, consulter un électricien qualifié.

MISE EN GARDE: Le verre est toujours fragile; maniez le(s) composant(s) et/ou l' (les) ampoule(s) avec prudence.

AVERTISSEMENT: Pour se conformer aux exigences du National Electrical Code et des Underwriters Laboratories, utilisez uniquement un endroit intérieur ou humide.

