

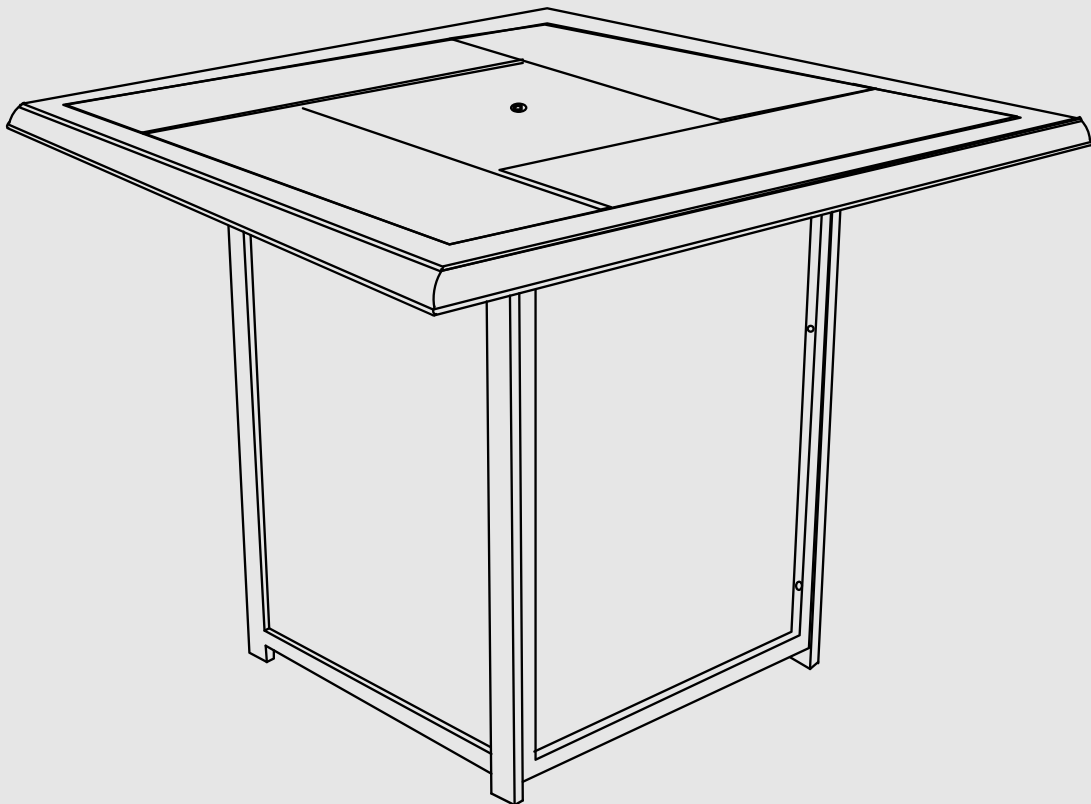

greemotion
inspired by nature

GM-2024



**Arosa Counter Height
Firepit Table**

EN

SAFETY INSTRUCTIONS AND WARNINGS:

- The product is to be used exclusively for its intended purpose.
- Regularly check the condition and functionality of the product. If you notice any damage, the product should no longer be used.
- Only use the product on solid and level ground.
- Make sure the product is positioned securely.
- **WARNING!** Risk of clamping/crushing fingers during assembly and disassembly of the product.

CLEANING AND MAINTENANCE

The effects of the weather can cause slight alterations to the appearance of the garden furniture. Please store the garden furniture in a dry place during winter. To clean the piece of furniture, use a damp cloth and for more stubborn dirt use a mild soap solution and a soft brush. Never use aggressive cleaning agents, pressure washers or steam jets to clean the product. To clean the cushion/seat cover quickly, use a damp soft cloth. Some stains can be removed with a mild soap solution and a soft brush. Never use abrasive cleaning agents or solvents. Make sure that the cushion filling does not become wet and that no moisture damage or mould can build up on the inside! When it rains or there is moisture in the air, the cushions and pads should be taken indoors and stored in a protected and dry location. Cushions/pads that have become wet should be allowed to dry out completely. Do not fill damp cushions/pads! The covers can be removed, allowing them to be washed in the washing machine. Remove the cover, turn it inside out and zip close. Wash the cover with similar colours in the washing machine.

IMPORTANT:

Be sure to read the washing instructions on the sewn-in care label on the covers!

FR

INDICATIONS DE SÉCURITÉ ET AVERTISSEMENT :

L'article doit uniquement être utilisé conformément à l'usage prévu.

- Vérifiez régulièrement l'état et le bon fonctionnement de l'article. Si vous constatez des dommages, l'article ne doit plus être utilisé.
- N'utilisez l'article que sur une surface plane et rigide.
- Veillez à ce que l'article soit stable.
- **ATTENTION !** Risque de coincement /d'écrasement lors du montage et du démontage de l'article.

NETTOYAGE ET ENTRETIEN

Les intempéries peuvent modifier légèrement l'aspect des meubles de jardin. Entrez les meubles de jardin au sec pendant l'hiver. Pour nettoyer les meubles de jardin, utilisez un chiffon humide et doux. En cas de salissures tenaces, utilisez une brosse souple et un savon doux. Ne nettoyez jamais les meubles de jardin avec des détergents agressifs, un nettoyeur à haute pression ou un jet de vapeur. Ne nettoyez jamais les meubles de jardin avec des détergents agressifs, un nettoyeur à haute pression ou un jet de vapeur. Utiliser un chiffon humide et doux pour nettoyer rapidement les housses de coussin/de siège. Les taches individuelles peuvent être éliminées à l'aide d'un savon doux et d'une brosse souple. Ne jamais nettoyer avec des détergents ou solvants agressifs. Veillez à ce que les rembourrages de coussin/de garniture ne soient pas mouillés et que des détériorations dues à l'humidité et des moisissures n'apparaissent pas à l'intérieur! Par temps humide ou pluvieux, rentrez les coussins/garnitures et les entreposez dans un lieu sec et protégé.

Bien laisser sécher les coussins/garnitures mouillés. Ne pas recouvrir des coussins/garnitures mouillés! Les housses peuvent être retirées afin de les nettoyer en machine. Retirez les housses, retournez-les et fermez les fermetures à glissière. Lavez les housses en machine avec du linge de la même couleur.

IMPORTANT:

Lors du nettoyage des housses, respectez impérativement les instructions d'entretien présentes sur l'étiquette cousue!

ES

INDICACIONES DE SEGURIDAD Y ADVERTENCIAS:

- Utilice el artículo exclusivamente conforme a las instrucciones de uso del mismo.
- Compruebe periódicamente el estado y la función del artículo. En caso de que observe daños, deje de utilizarlo.
- Use el artículo únicamente sobre una superficie plana y firme.
- Asegúrese de que el artículo está estable.
- **¡ATENCIÓN!** Existe riesgo de atrapamiento o aplastamiento al montar y desmontar el artículo.

LIMPIEZA Y MANTENIMIENTO

Las condiciones meteorológicas pueden cambiar la apariencia de los muebles de jardín. Durante el invierno, almacene los muebles de jardín en un lugar seco. Para limpiar los muebles de jardín, use un paño suave y húmedo, y para la suciedad más difícil, use una solución jabonosa y un cepillo suave. No limpie nunca los muebles de jardín con detergentes agresivos, con un limpiador de alta presión o con un chorro de vapor. Para limpiar rápidamente los cojines/las fundas de los asientos, use un paño suave y húmedo. Las manchas superficiales se pueden eliminar con una solución jabonosa y un cepillo suave. No las limpie en ningún caso con detergentes abrasivos ni disolventes. Asegúrese de que el relleno de los cojines/las colchonetas no se moja y de que no se crea moho ni se generan daños por la humedad en el interior. Cuando llueva y haya un clima húmedo, meta dentro de casa los cojines/las colchonetas y guárdelos en un lugar seco y protegido. Deje que se sequen bien los cojines/las colchonetas húmedos o mojados. ¡No use cojines ni colchonetas húmedos!

Para limpiar debidamente las fundas en la lavadora, extraígalas. Retire las fundas, deles la vuelta y cierre la cremallera. Ponga las fundas con colores similares en la lavadora.

IMPORTANTE:

Cuando limpie las fundas, asegúrese sobre todo de comprobar primero las indicaciones de mantenimiento de la etiqueta.

Need Help?

1-909-348-5495



greemotionusa.com



support@greemotionusa.com



/greemotionUSA

PARTS

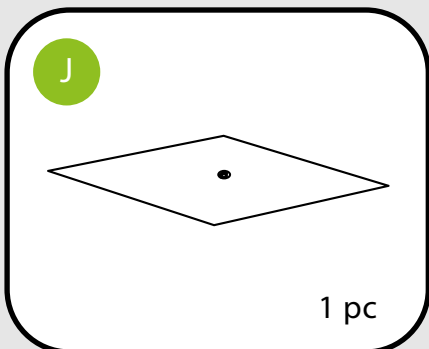
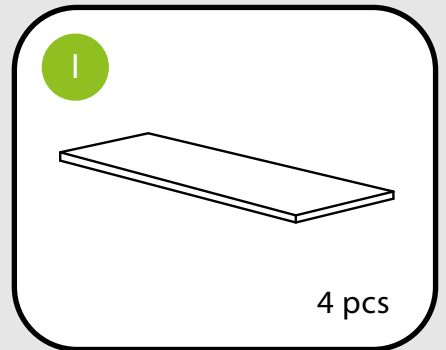
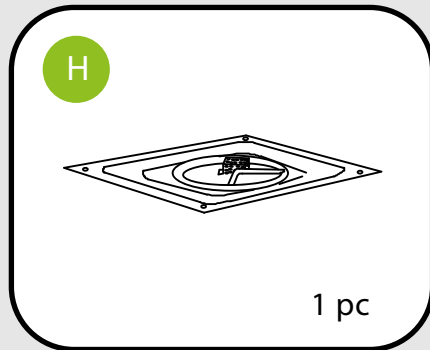
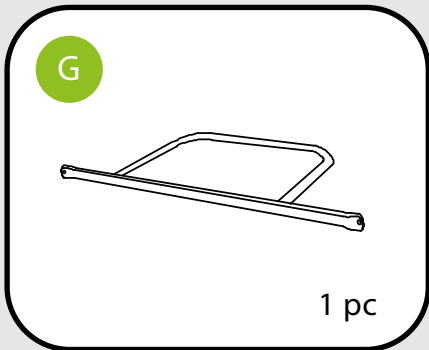
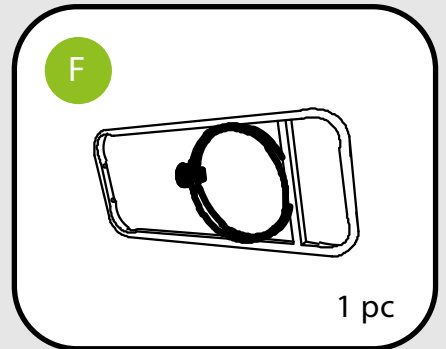
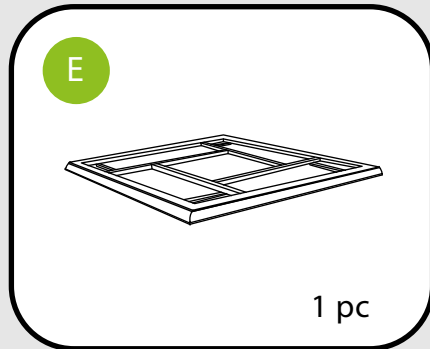
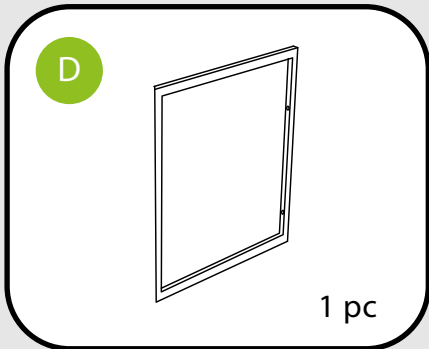
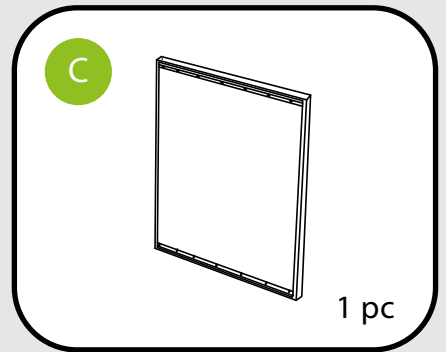
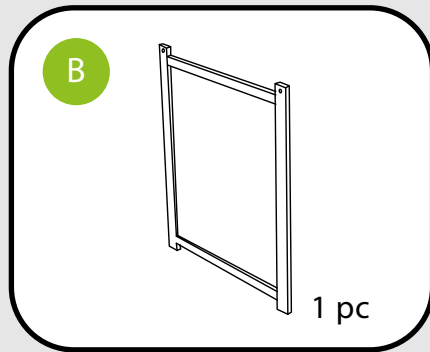
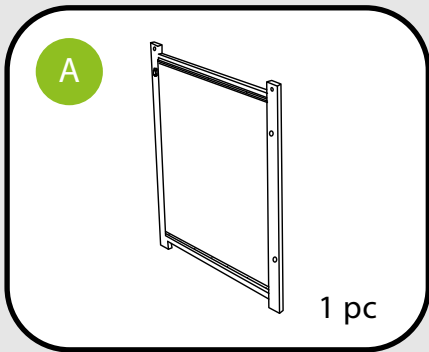

HARDWARE

K

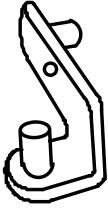

1 pc

L

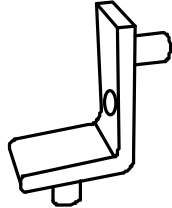

1 pc

M

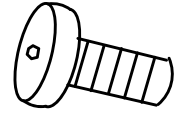

M6*10

4 pcs

N

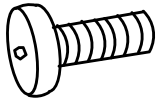

M6*15

6 pcs

O

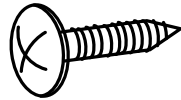

ST4.2*16

2 pcs

P

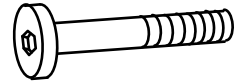

M6*40

4 pcs

Q

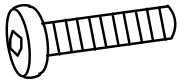

M6*25

4 pcs

R



14 pcs

S



1 pc

ASSEMBLY INSTRUCTIONS

1

Fasten frames (#A, B) to rear frame (#C) by using bolts (#P) and washers (#R). Keep the bolts loose.

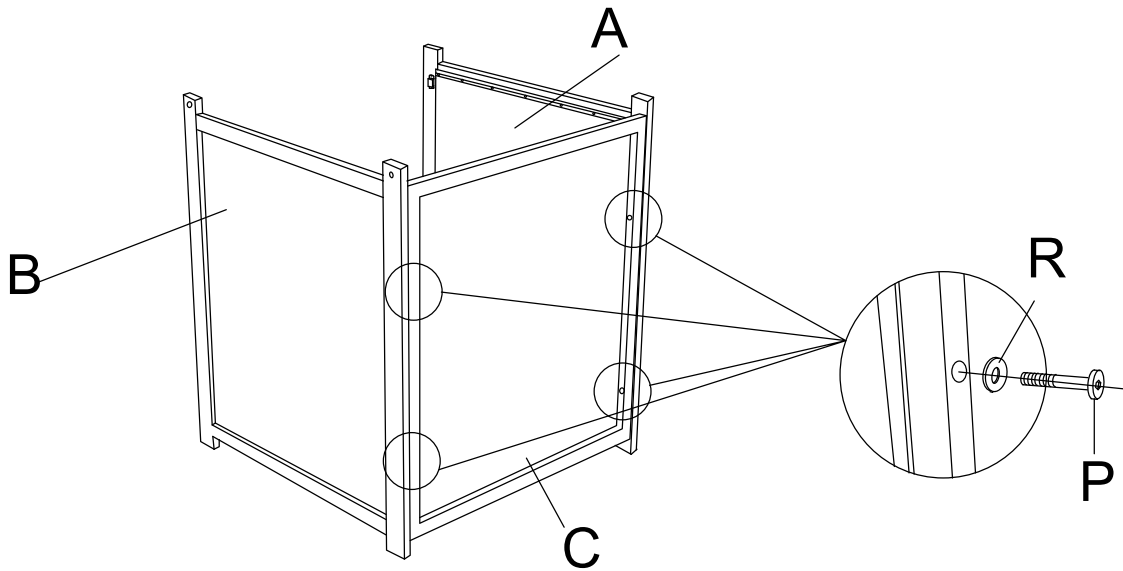

2

Fasten the bottom frame (#F) to the frames (#A, B) by using bolts (#Q) and washers (#R).

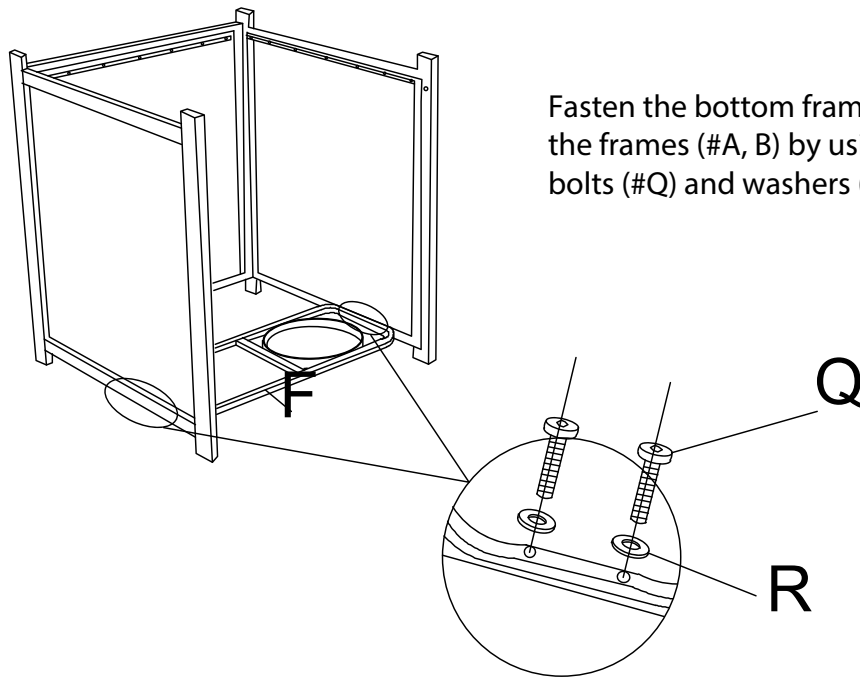

ASSEMBLY INSTRUCTIONS

3

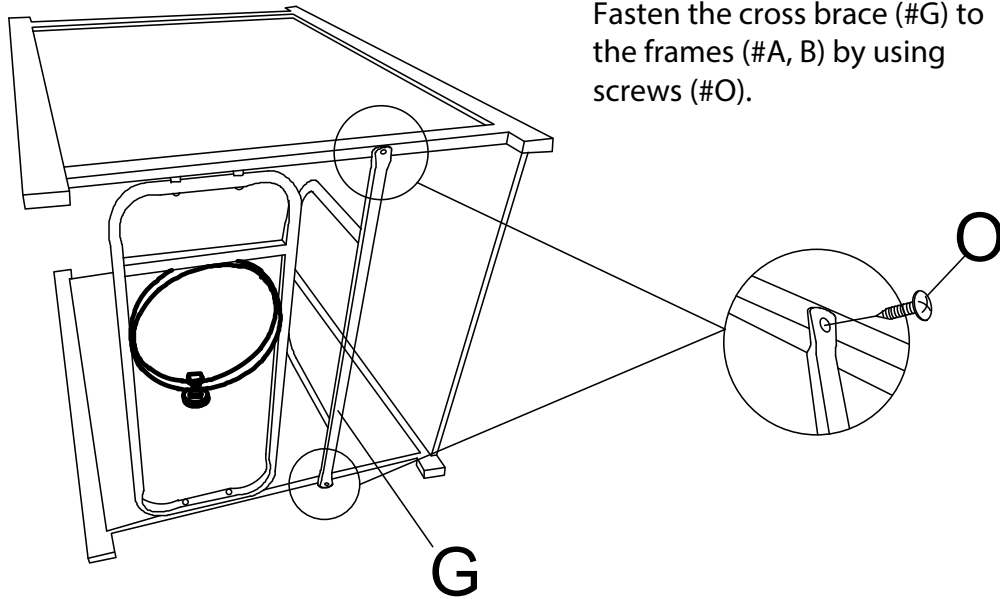

4

Fasten the lower connector (#K) on the inner side of frame (#B) by using bolt (#N) and washer (#R).

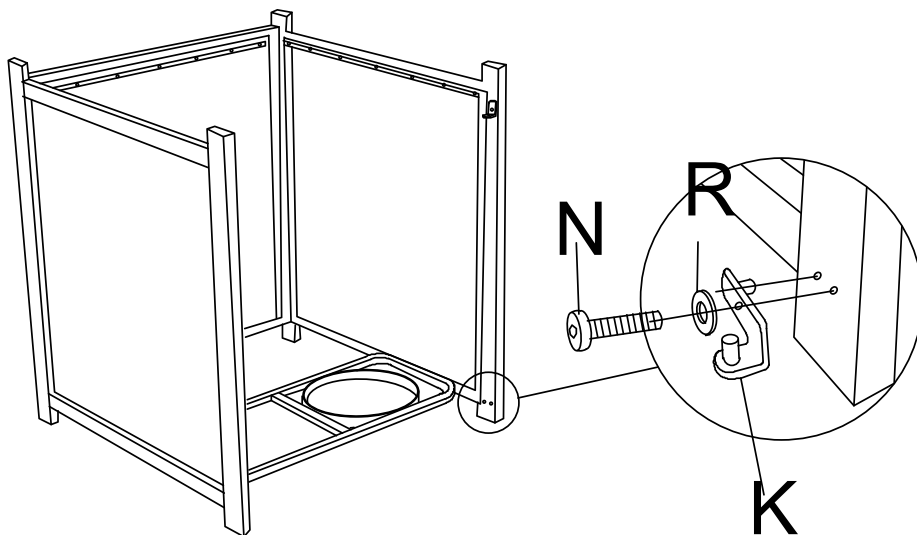

ASSEMBLY INSTRUCTIONS

5

Align and connect the front door (#D) with the lower connector (#K).

Insert the upper connector (#L) into the top of front door (#D).
Fasten the upper connector (#L) to the frame (#B) by using bolt (#N) and washer (#R).

Completely tighten all bolts.

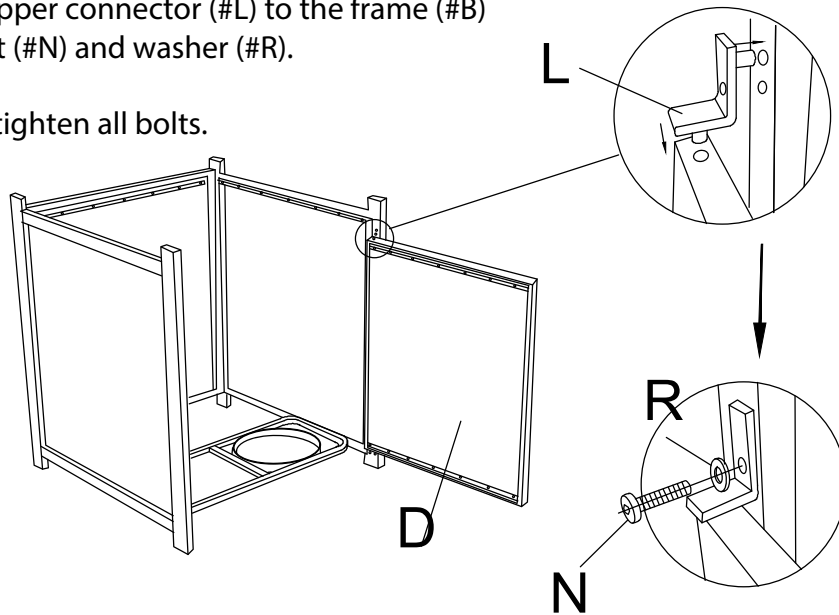

6

Place the table top (#E) onto the frame assembly.
Fasten together using bolts (#N) and washers (#R).

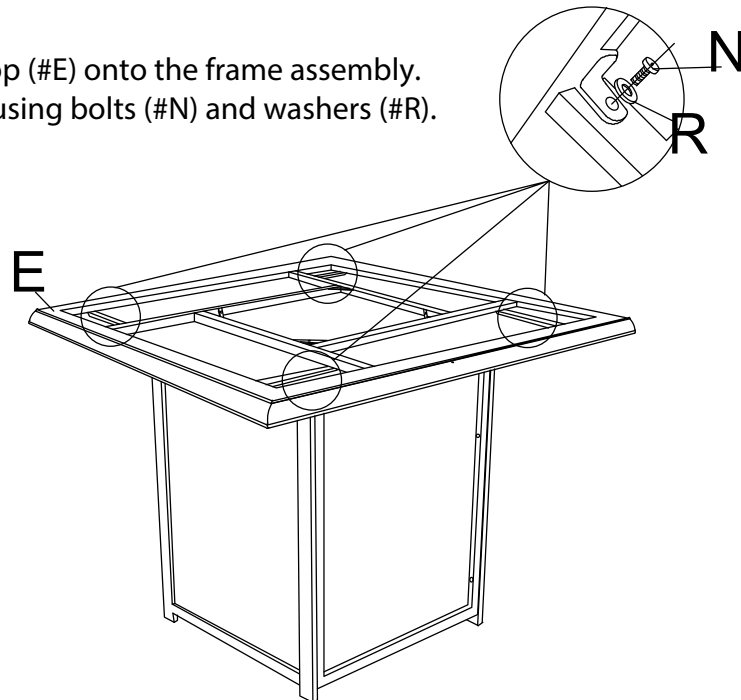

ASSEMBLY INSTRUCTIONS

7

Fasten the burning system (#H) to center of table top (#E) by using bolts (#M). Make sure that all bolts are completely tightened.

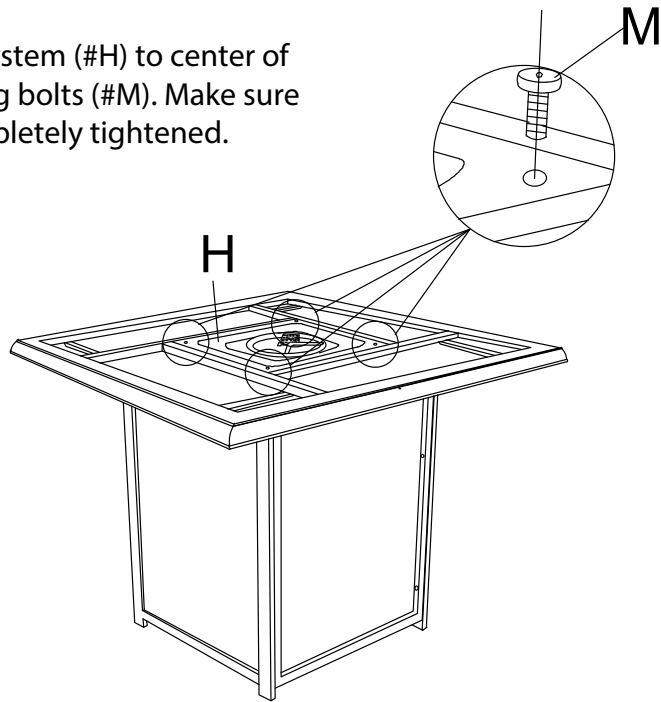

8

Place the tiles (#I) and burner cover (#J) on table top (#E).

Note: If any EVA foams are missing, extra EVA forms can be found in the hardware kit.

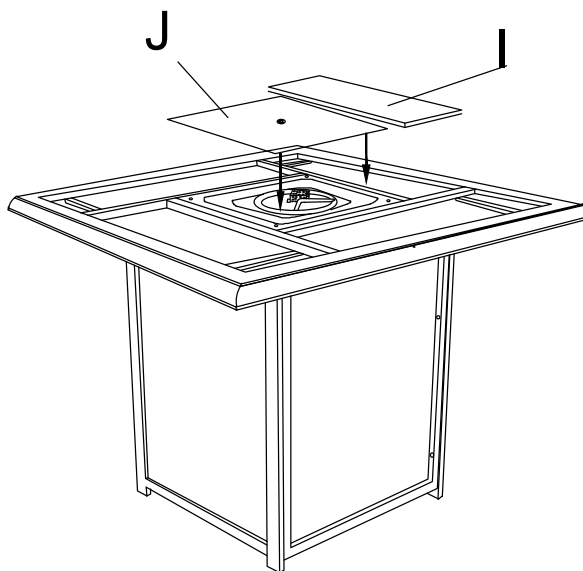

ASSEMBLY INSTRUCTIONS

9

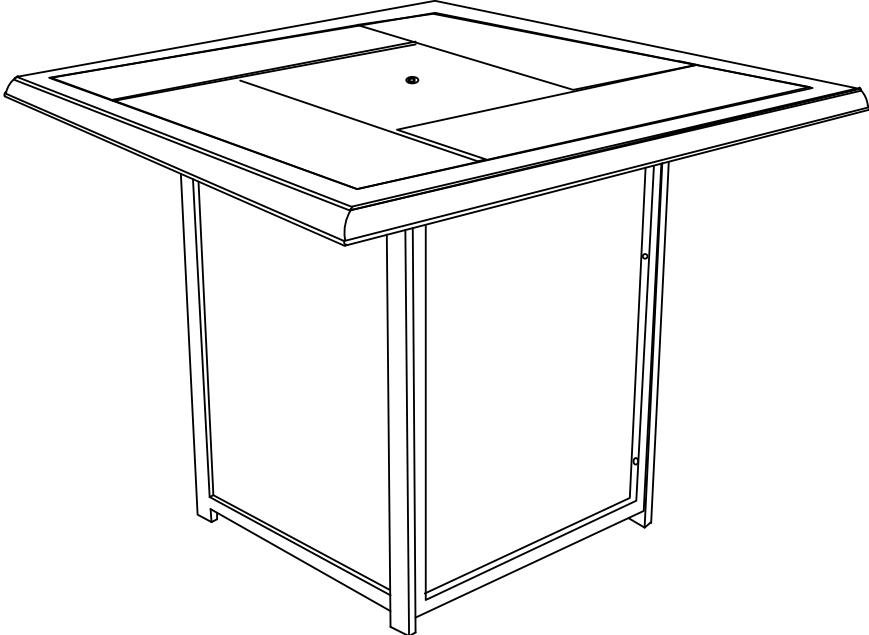

Finished



GM-2025-2PK



Arosa Swivel Counter Height Chair

EN

SAFETY INSTRUCTIONS AND WARNINGS:

- The product is to be used exclusively for its intended purpose.
- Regularly check the condition and functionality of the product. If you notice any damage, the product should no longer be used.
- Only use the product on solid and level ground.
- Make sure the product is positioned securely.
- **WARNING!** Risk of clamping/crushing fingers during assembly and disassembly of the product.

CLEANING AND MAINTENANCE

The effects of the weather can cause slight alterations to the appearance of the garden furniture. Please store the garden furniture in a dry place during winter. To clean the piece of furniture, use a damp cloth and for more stubborn dirt use a mild soap solution and a soft brush. Never use aggressive cleaning agents, pressure washers or steam jets to clean the product. To clean the cushion/seat cover quickly, use a damp soft cloth. Some stains can be removed with a mild soap solution and a soft brush. Never use abrasive cleaning agents or solvents. Make sure that the cushion filling does not become wet and that no moisture damage or mould can build up on the inside! When it rains or there is moisture in the air, the cushions and pads should be taken indoors and stored in a protected and dry location. Cushions/pads that have become wet should be allowed to dry out completely. Do not fill damp cushions/pads! The covers can be removed, allowing them to be washed in the washing machine. Remove the cover, turn it inside out and zip close. Wash the cover with similar colours in the washing machine.

IMPORTANT:

Be sure to read the washing instructions on the sewn-in care label on the covers!

FR

INDICATIONS DE SÉCURITÉ ET AVERTISSEMENT :

L'article doit uniquement être utilisé conformément à l'usage prévu.

- Vérifiez régulièrement l'état et le bon fonctionnement de l'article. Si vous constatez des dommages, l'article ne doit plus être utilisé.
- N'utilisez l'article que sur une surface plane et rigide.
- Veillez à ce que l'article soit stable.
- **ATTENTION !** Risque de coincement /d'écrasement lors du montage et du démontage de l'article.

NETTOYAGE ET ENTRETIEN

Les intempéries peuvent modifier légèrement l'aspect des meubles de jardin. Entrez les meubles de jardin au sec pendant l'hiver. Pour nettoyer les meubles de jardin, utilisez un chiffon humide et doux. En cas de salissures tenaces, utilisez une brosse souple et un savon doux. Ne nettoyez jamais les meubles de jardin avec des détergents agressifs, un nettoyeur à haute pression ou un jet de vapeur. Ne nettoyez jamais les meubles de jardin avec des détergents agressifs, un nettoyeur à haute pression ou un jet de vapeur. Utilisez un chiffon humide et doux pour nettoyer rapidement les housses de coussin/de siège. Les taches individuelles peuvent être éliminées à l'aide d'un savon doux et d'une brosse souple. Ne jamais nettoyer avec des détergents ou solvants agressifs. Veillez à ce que les rembourrages de coussin/de garniture ne soient pas mouillés et que des détériorations dues à l'humidité et des moisissures n'apparaissent pas à l'intérieur! Par temps humide ou pluvieux, rentrez les coussins/garnitures et les entreposez dans un lieu sec et protégé.

Bien laisser sécher les coussins/garnitures mouillés. Ne pas recouvrir des coussins/garnitures mouillés! Les housses peuvent être retirées afin de les nettoyer en machine. Retirez les housses, retournez-les et fermez les fermetures à glissière. Lavez les housses en machine avec du linge de la même couleur.

IMPORTANT:

Lors du nettoyage des housses, respectez impérativement les instructions d'entretien présentes sur l'étiquette cousue!

ES

INDICACIONES DE SEGURIDAD Y ADVERTENCIAS:

- Utilice el artículo exclusivamente conforme a las instrucciones de uso del mismo.
- Compruebe periódicamente el estado y la función del artículo. En caso de que observe daños, deje de utilizarlo.
- Use el artículo únicamente sobre una superficie plana y firme.
- Asegúrese de que el artículo está estable.
- **¡ATENCIÓN!** Existe riesgo de atrapamiento o aplastamiento al montar y desmontar el artículo.

LIMPIEZA Y MANTENIMIENTO

Las condiciones meteorológicas pueden cambiar la apariencia de los muebles de jardín. Durante el invierno, almacene los muebles de jardín en un lugar seco. Para limpiar los muebles de jardín, use un paño suave y húmedo, y para la suciedad más difícil, use una solución jabonosa y un cepillo suave. No limpie nunca los muebles de jardín con detergentes agresivos, con un limpiador de alta presión o con un chorro de vapor. Para limpiar rápidamente los cojines/las fundas de los asientos, use un paño suave y húmedo. Las manchas superficiales se pueden eliminar con una solución jabonosa y un cepillo suave. No las limpie en ningún caso con detergentes abrasivos ni disolventes. Asegúrese de que el relleno de los cojines/las colchonetas no se moja y de que no se crea moho ni se generan daños por la humedad en el interior. Cuando llueva y haya un clima húmedo, meta dentro de casa los cojines/las colchonetas y guárdelos en un lugar seco y protegido. Deje que se sequen bien los cojines/las colchonetas húmedos o mojados. ¡No use cojines ni colchonetas húmedos!

Para limpiar debidamente las fundas en la lavadora, extráigalas. Retire las fundas, deles la vuelta y cierre la cremallera. Ponga las fundas con colores similares en la lavadora.

IMPORTANTE:

Cuando limpie las fundas, asegúrese sobre todo de comprobar primero las indicaciones de mantenimiento de la etiqueta.

Need Help?

1-909-348-5495



greemotionusa.com



support@greemotionusa.com



/greemotionUSA

PARTS

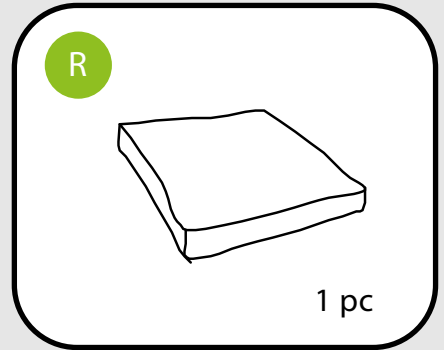
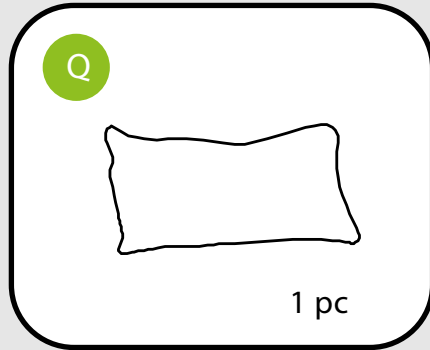
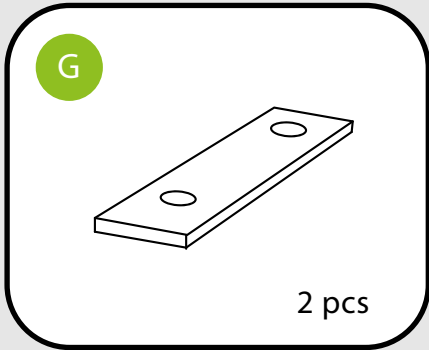
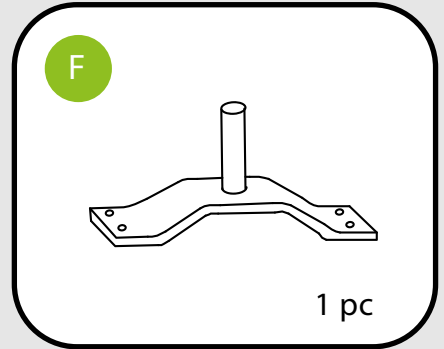
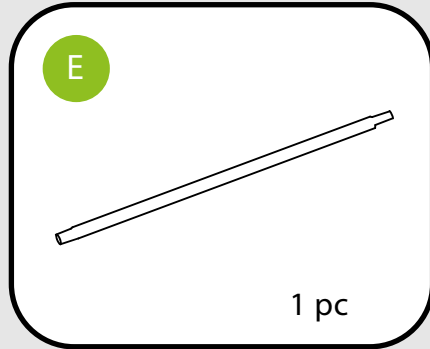
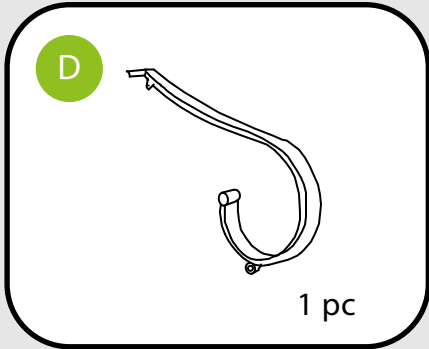
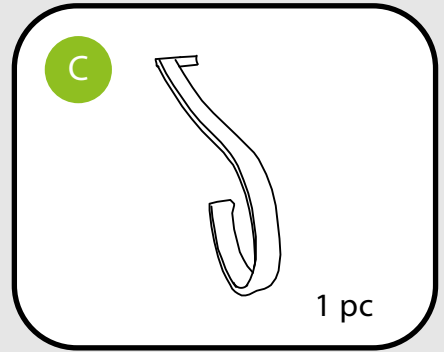
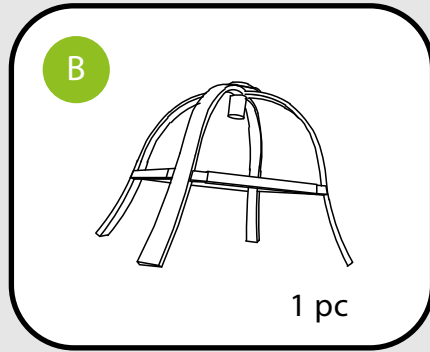
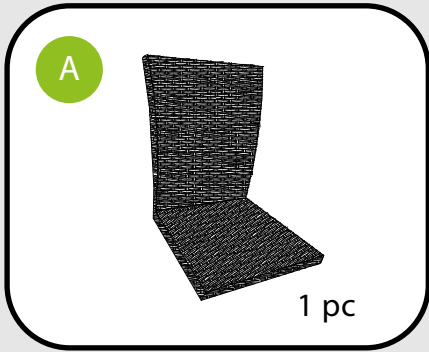

PARTS

H

M6*15



2 pcs

I

M8*30

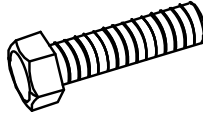

4 pcs

J

Ø12*Ø6.2*1.0

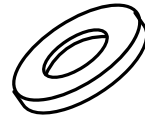

4 pcs

K

Ø16*Ø8.2*1.0

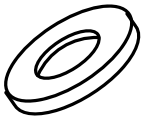

8 pcs

L

φ12.2*φ8.5*1.8 (M8)

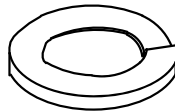

4 pcs

M

M8

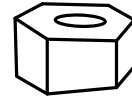

4 pcs

N

M6*45

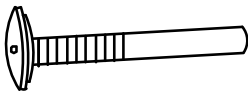

1 pc

O

M6*35

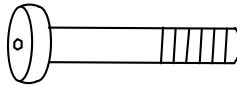

2 pcs

P



1 pc

S



1 pc

T

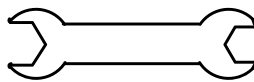

2 pcs

ASSEMBLY INSTRUCTIONS

1

Connect Backrest Rod (#E) between Armrests (#C, D), then attach to Seat (#A). For the underside of the seat, use bolts (#O) and washers (#J). To secure the backrest, use bolts (#H) and washers (#J).

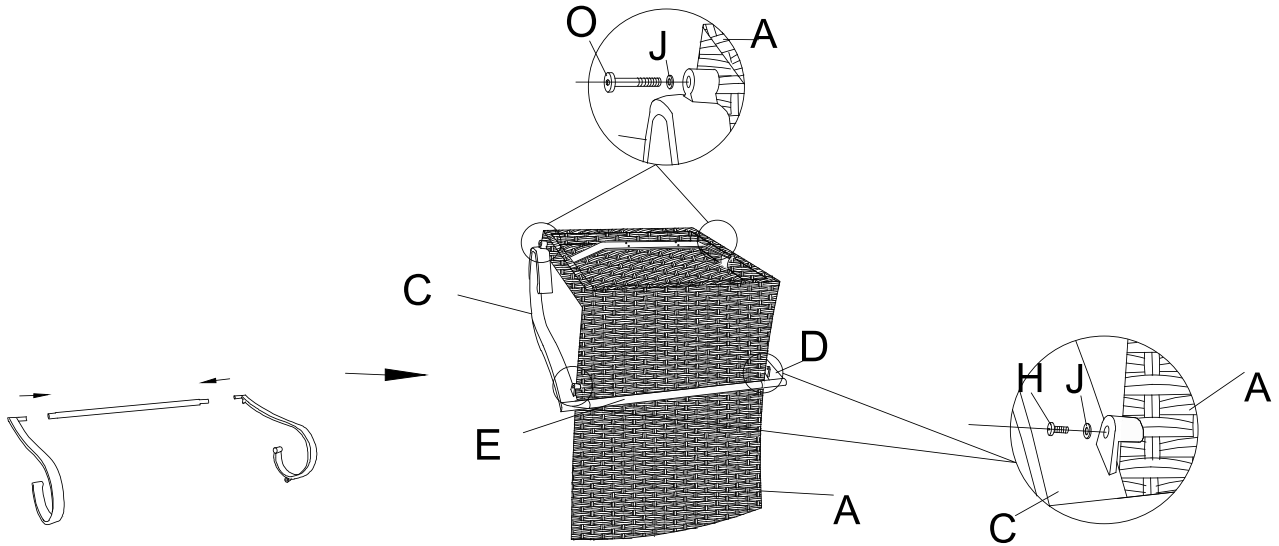

2

Place Plate (#G) within inner metal beam of Seat (#A) and Swivel Bar (#F) on outer side of Seat (#A). Align bolts (#I) through washers (#K), Plate (#G), Seat (#A) and Swivel Bar (#F). Secure the outer end with lock washer (#K), split washer (#L) and nut (#M). Tighten completely.

Align Base (#B) to Swivel Bar (#F) and secure center with bolt (#N) and washer (#P).

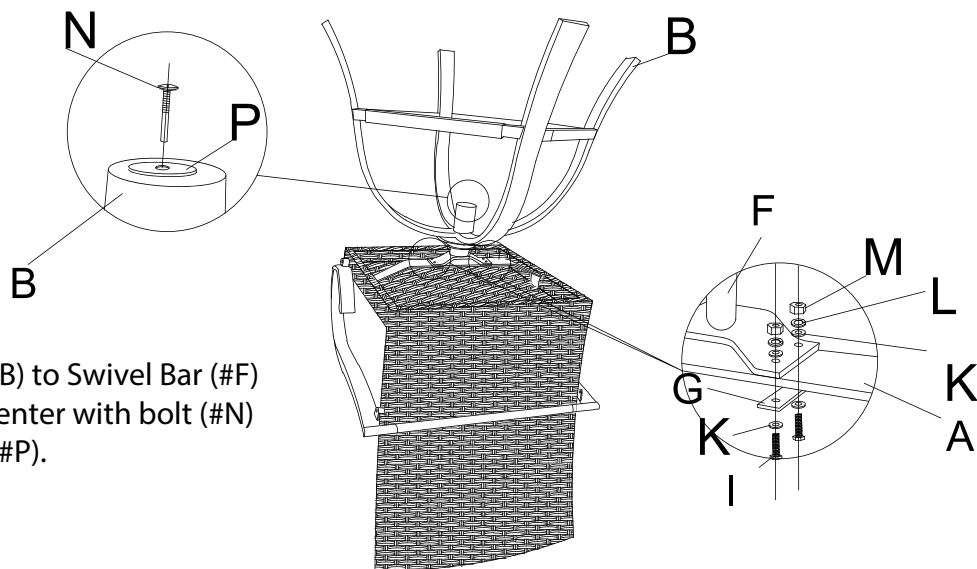

ASSEMBLY INSTRUCTIONS

3

Rotate upright. Place Seat Cushion (#R) and Lumbar Pillow (#Q).

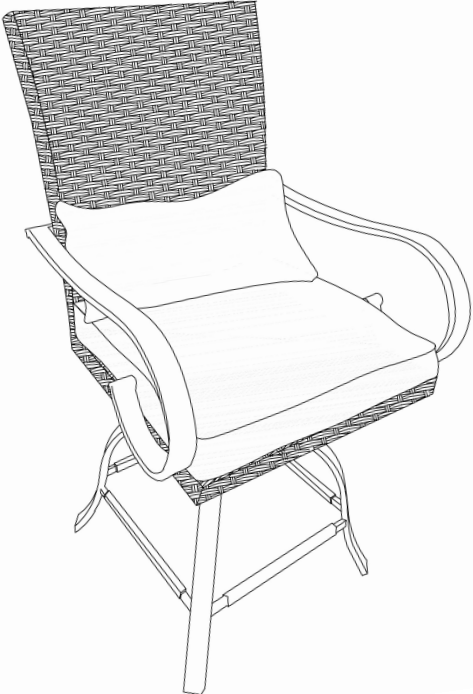
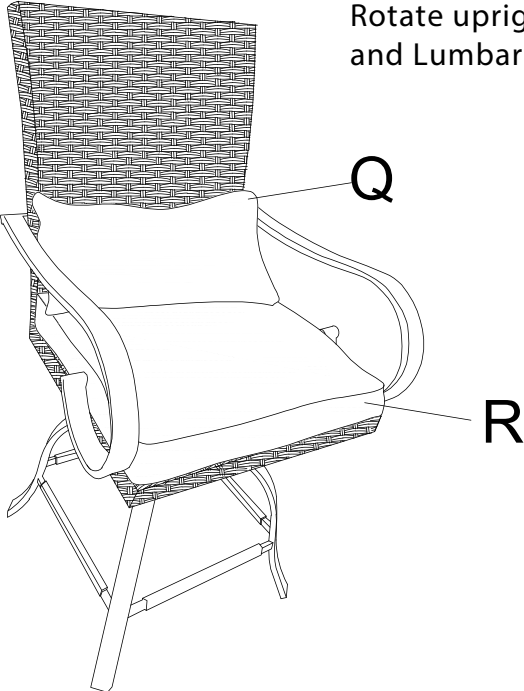

Finished