

Assembly Instructions

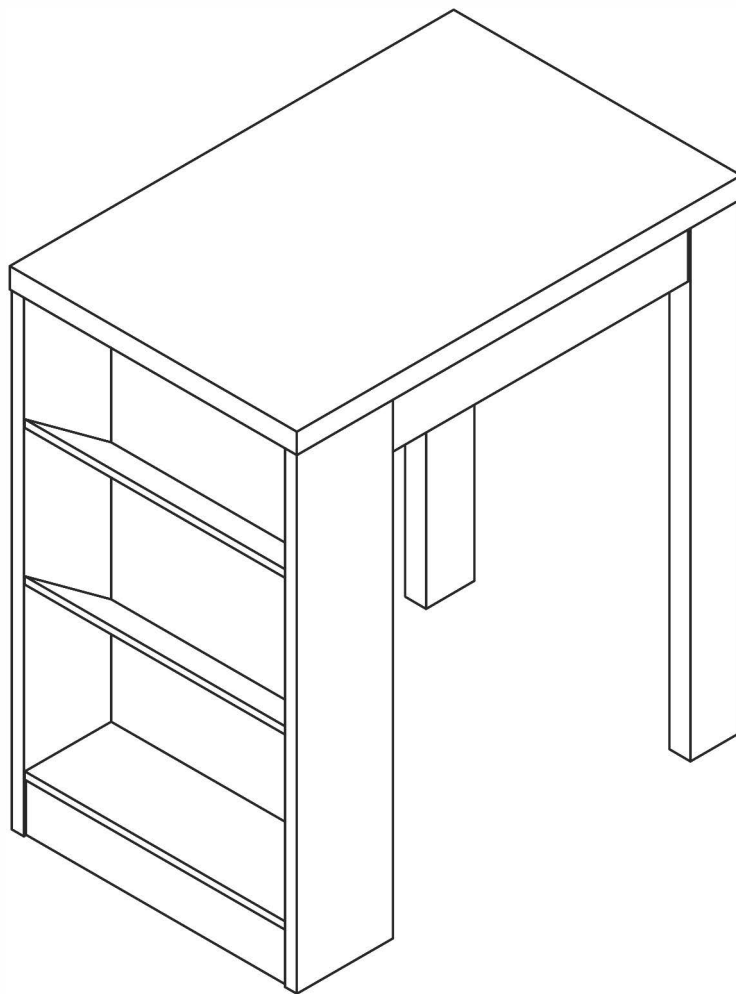

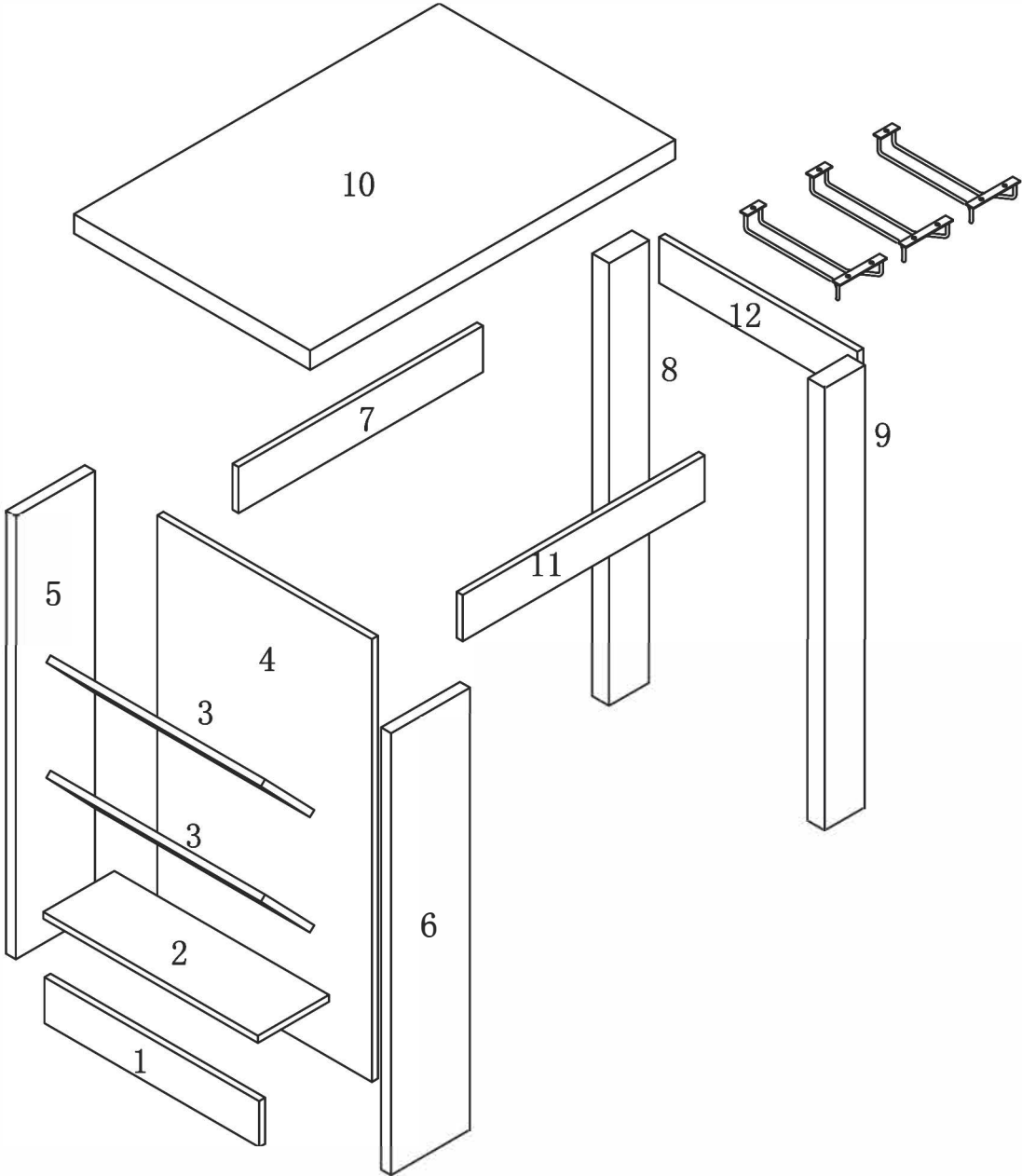







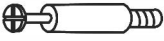

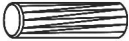

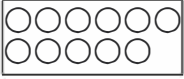

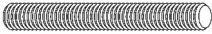
PARTS IDENTIFICATION

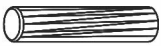

(1)	1pc	(6)	1pc	(11)	1pc
(2)	1pc	(7)	1pc	(12)	1pc
(3)	2pcs	(8)	1pc		
(4)	1pc	(9)	1pc		
(5)	1pc	(10)	1pc		

HARDWARE IDENTIFICATION

A		L29	24pcs
B		ø15	24pcs
C		ø8×25	20pcs
D		ø5	1set
E		ø4×16	9pcs
F		ø18	11pcs
G		M13	1pc
H		M8×65	2pcs
I		M8	2sets
J		ø45	2pcs
K		ø16	5pcs
L		L340	3pcs
M			1pc
N		ø3×16	2pcs
O	 BK	ø8×40	10pcs
P		Glue: For securing please apply to wood dowel first before inserting into panel	1pc

Assembly Instructions

STEP 1

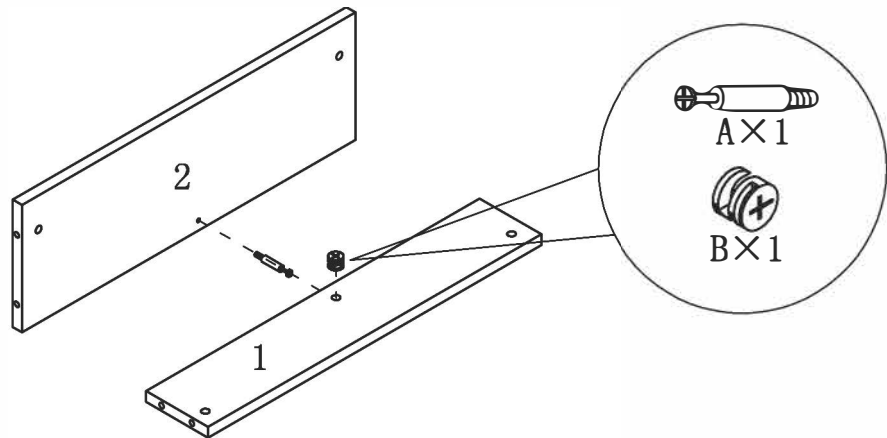

STEP 2

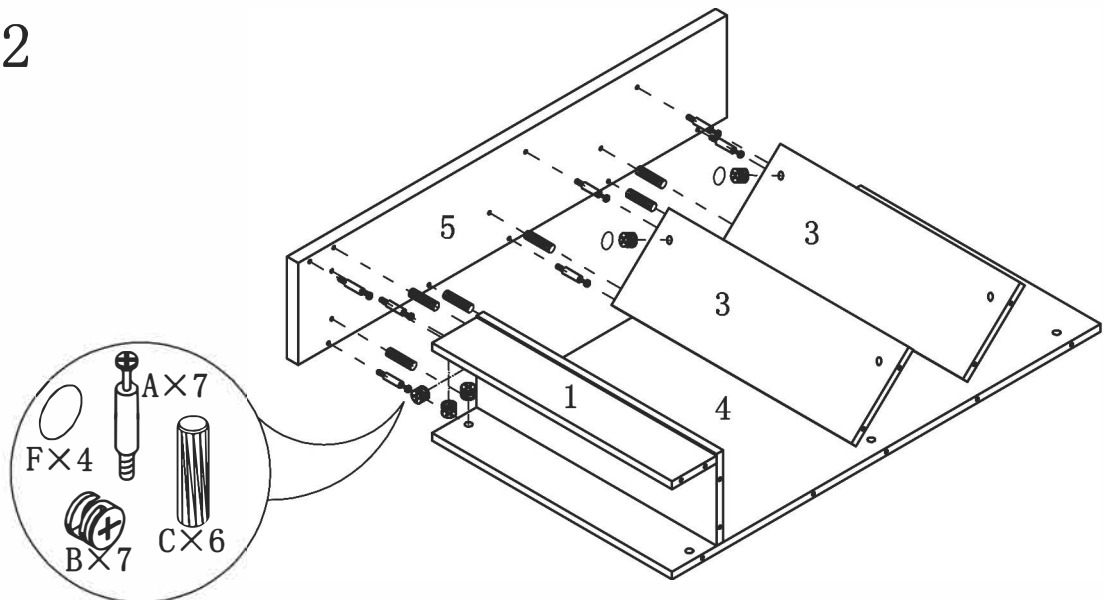

STEP 3

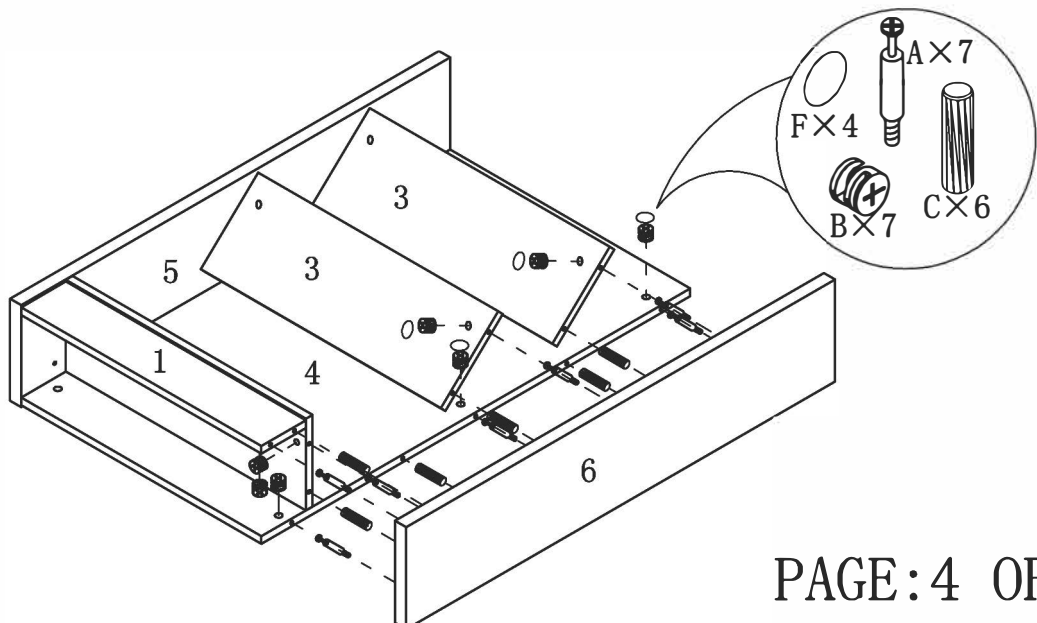

Assembly Instructions

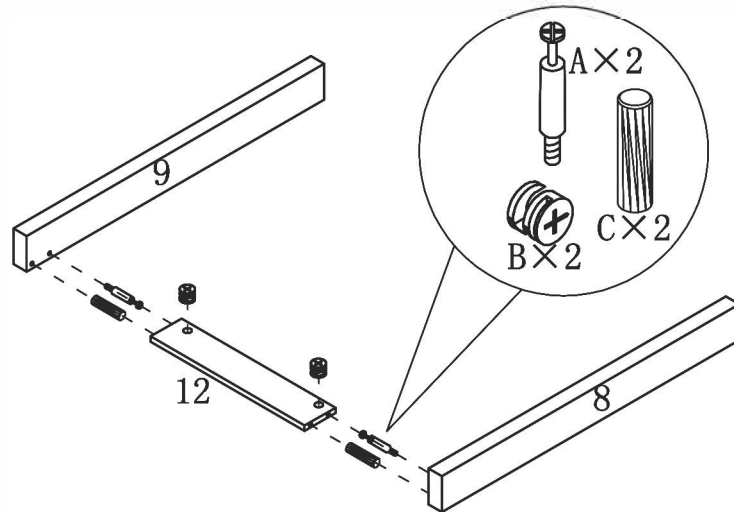

STEP 4

STEP 5

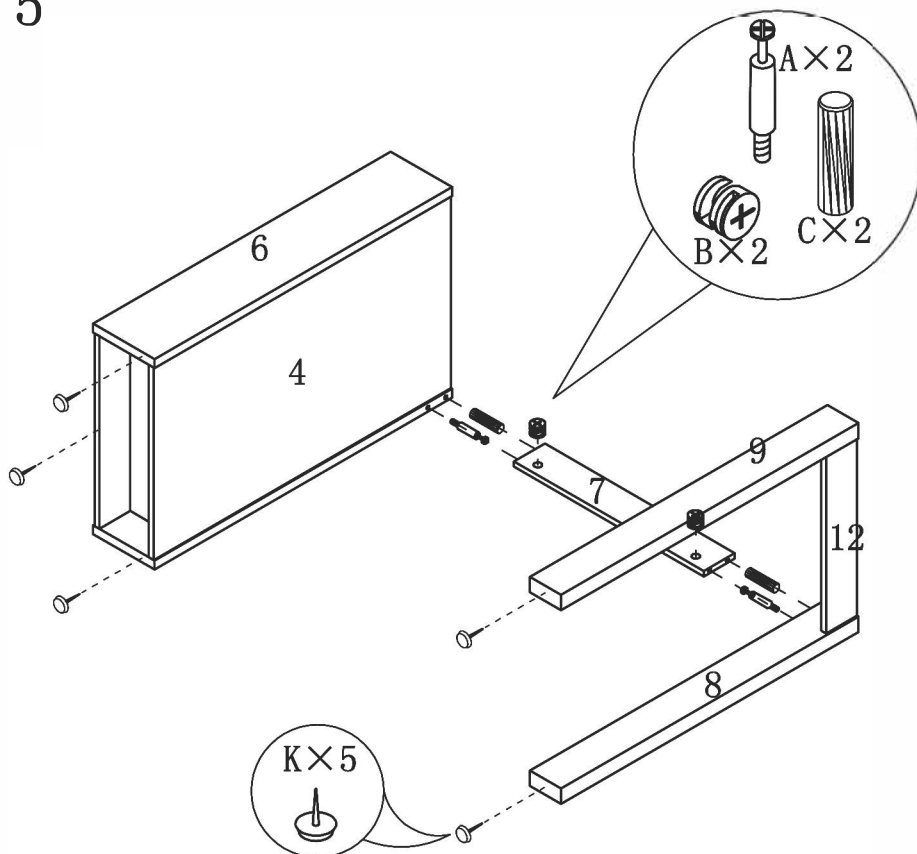

Assembly Instructions

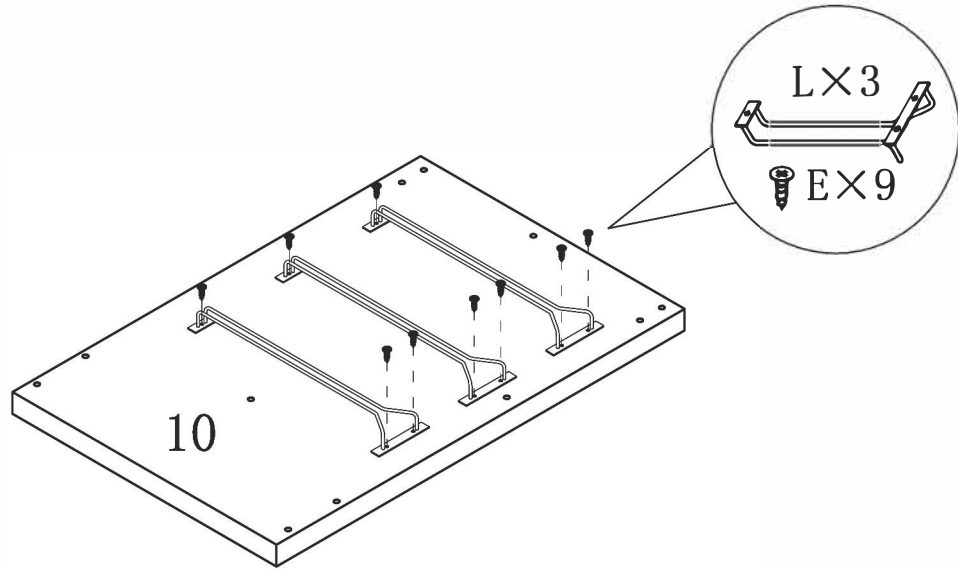

STEP 6

STEP 7

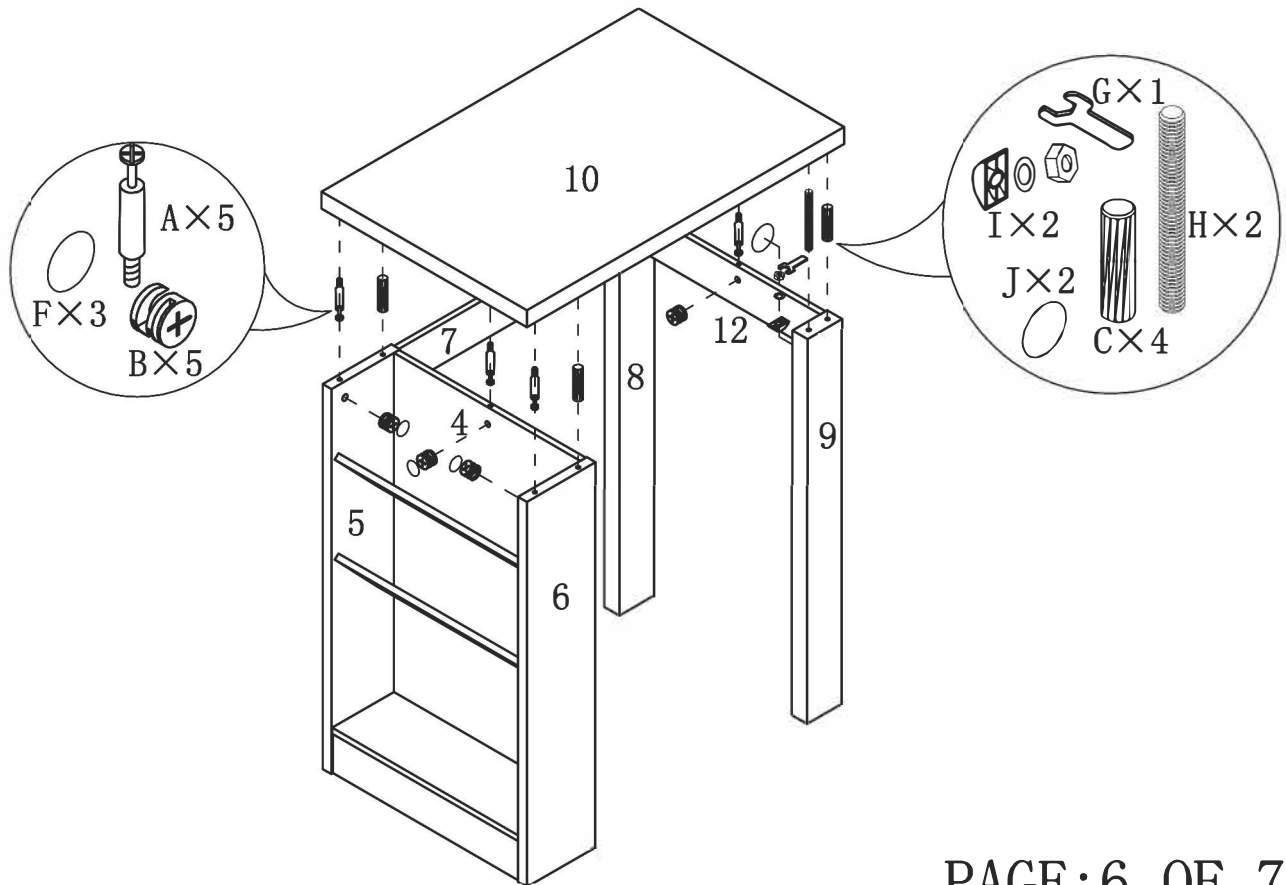

Assembly Instructions

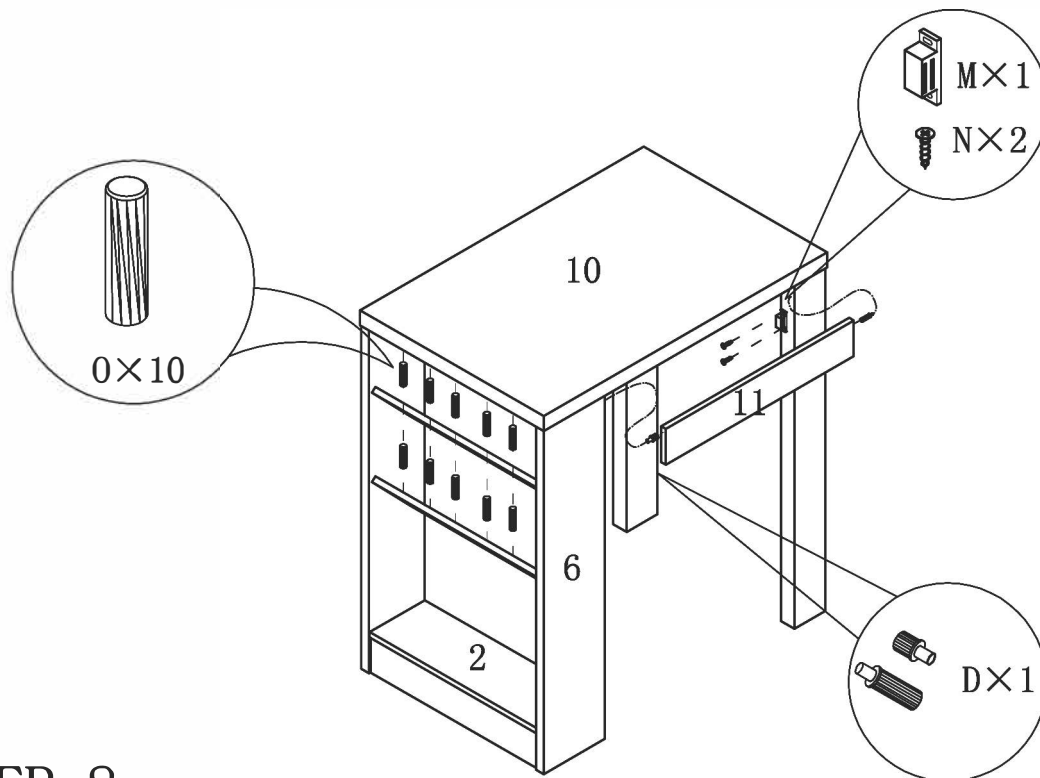

STEP 8

STEP 9

