

CAUTION:

DO NOT SLIDE BED; PICK BED UP TO REPOSITION/LOCATE IT UPON COMPLETING ASSEMBLY

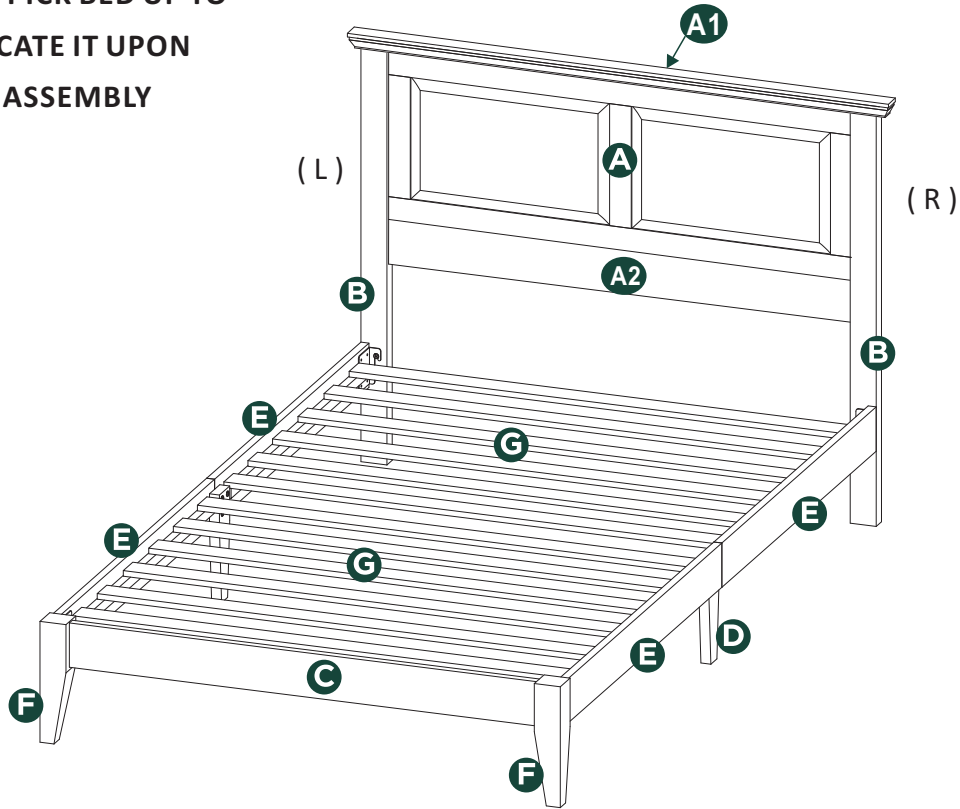

Revision Number: 01

Twin Bed

Components

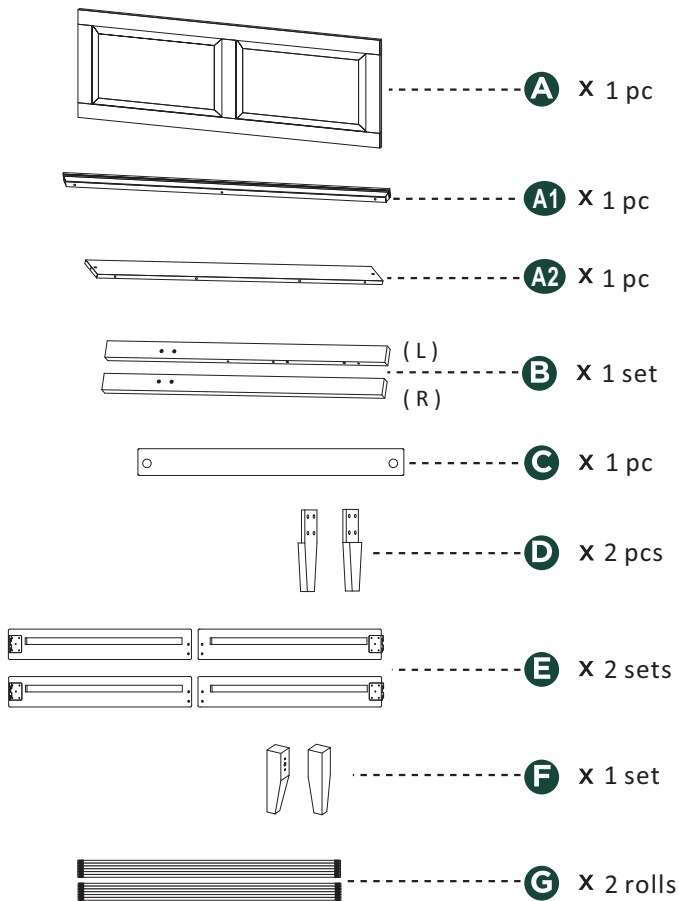

Hardware

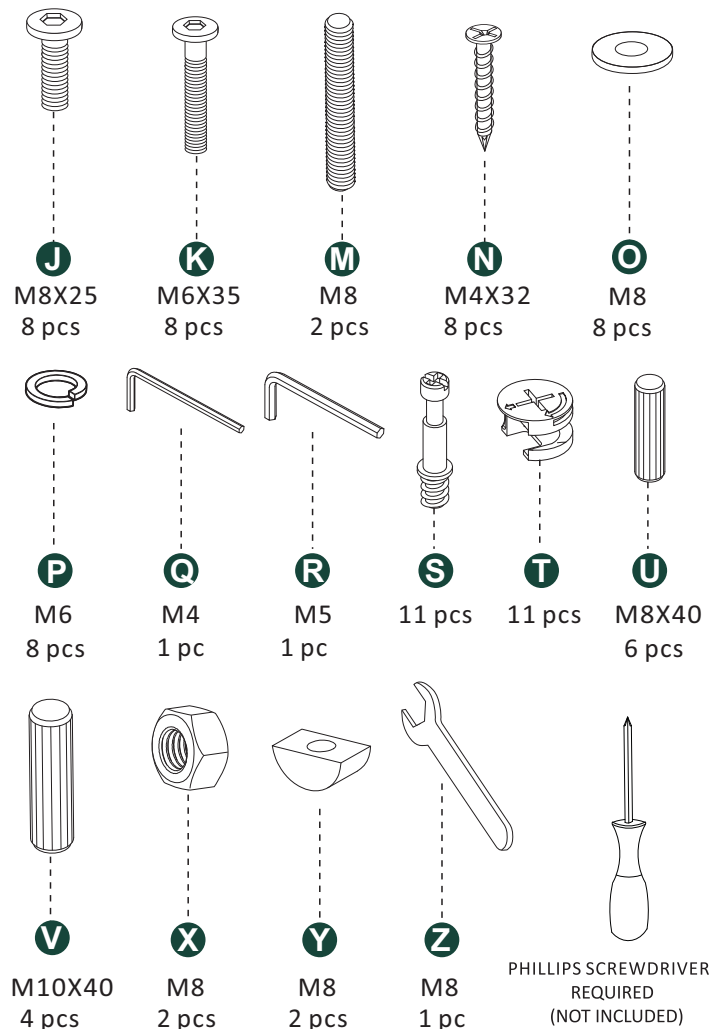

CAUTION:

Do not attempt to slide the bed once it is fully assembled. To avoid structural damage while moving your assembled bed, any mattress and bedding should be removed from the bedframe. Then the bedframe should be lifted and carried (not slid) to your desired location.

When placing furniture on non-carpeted flooring, we recommend the use of floor protection such as an area rug or furniture pads. Area rugs and padding not included with purchase.

Max Weight Limit 600lbs.

When using an adjustable base please use the legs provided with the adjustable base for maximum support.

Using zero clearance adjustable bases without legs directly on the slats is NOT recommended and will void your warranty.

1

Use screwdriver to thread cam bolts (S) to panel (A1), (A2), and leg (B). Insert wooden dowel (U) to leg (B) and panel (A2) as shown below.

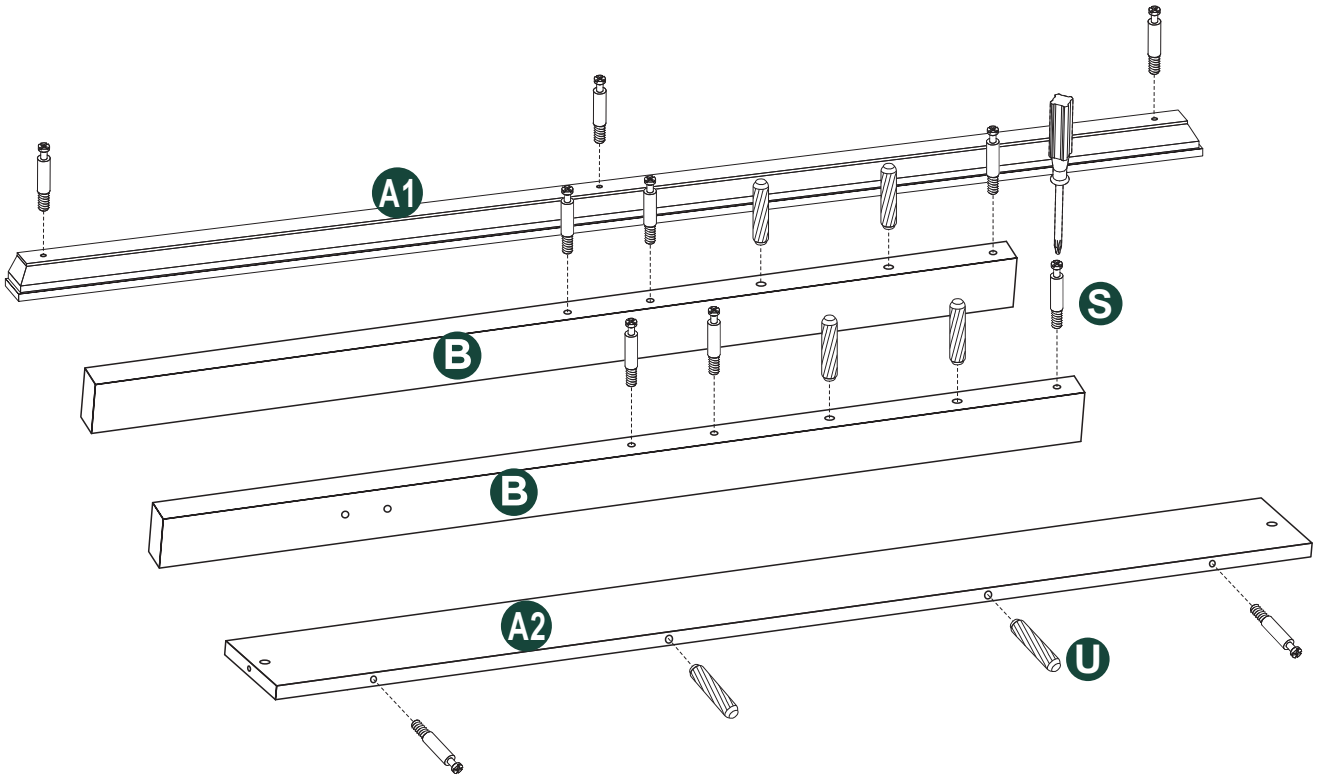
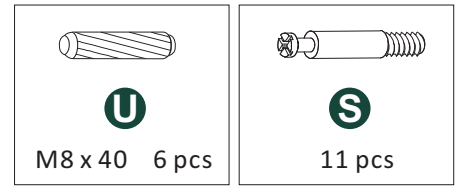
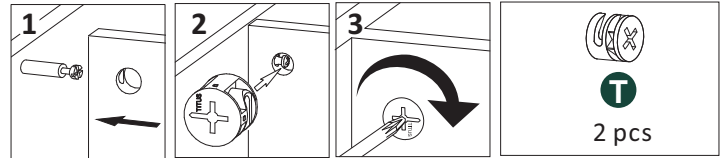
**2**

Insert panel (A2) to panel (A). Insert cam lock (T) to the holes of panel (A) as shown below. Use screwdriver to turn cam lock (T) to secure panel (A2) to panel (A). Do not try over tighten, this may break the cam lock.

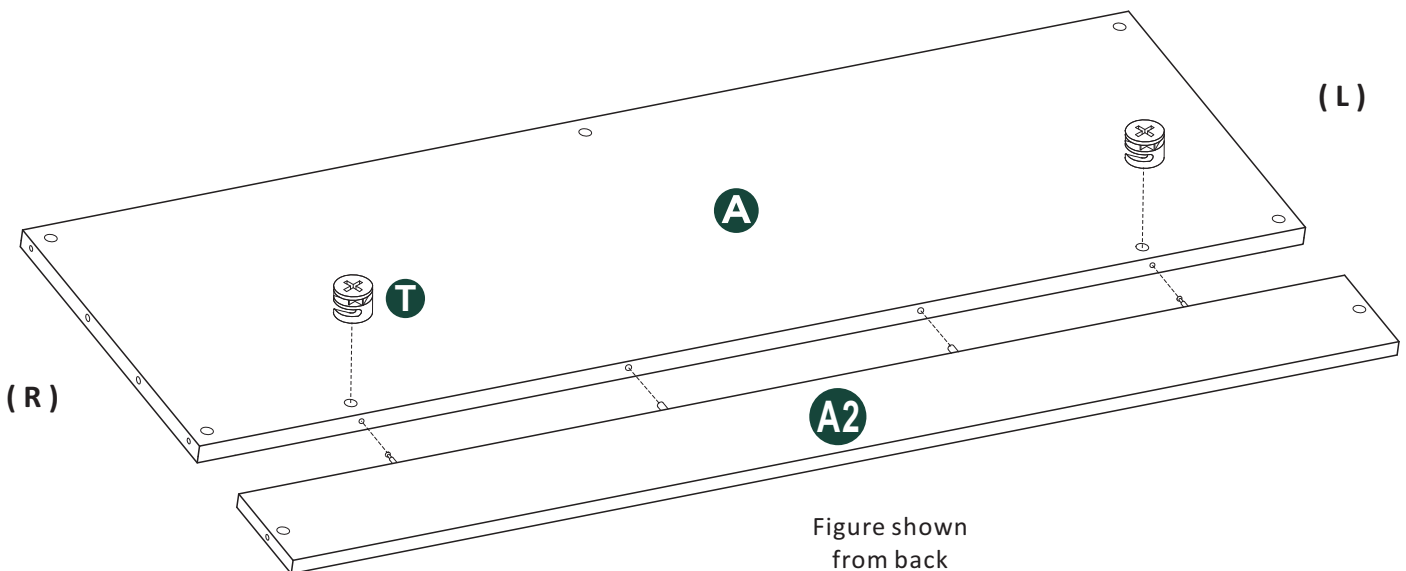

3

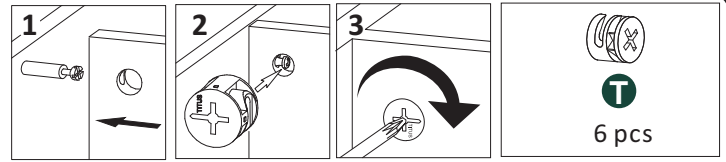

Insert leg (B) to end of panel (A) and (A2). Insert cam lock (T) to the holes of panel (A) and (A2) as shown below. Use screwdriver to turn cam lock (T) to secure leg (B) to panel (A) and (A2). Do not try over tighten, this may break the cam lock.

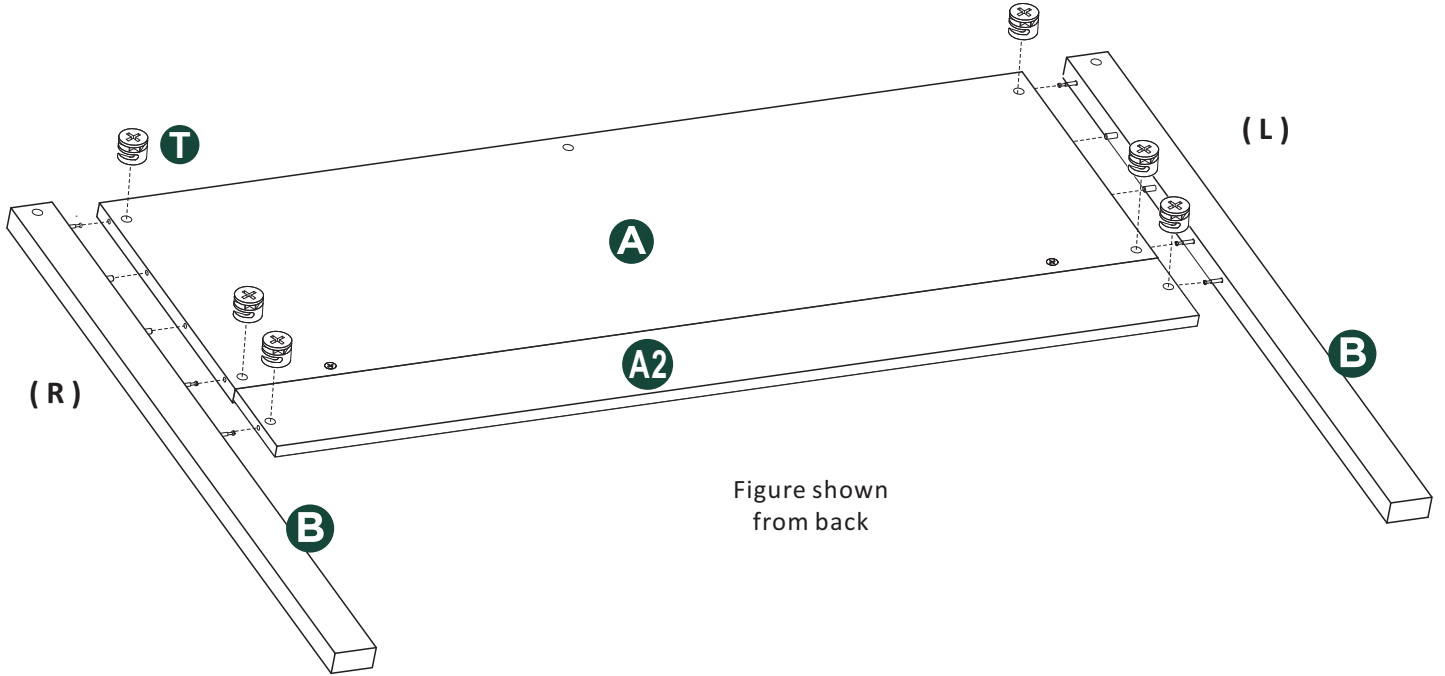

4

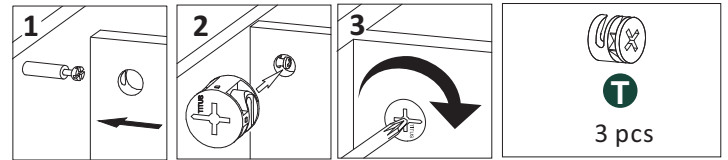

Insert panel (A1) to top end of panel (A) and leg (B). Insert cam lock (T) to the holes of panel (A) and leg (B) as shown below. Use screwdriver to turn cam lock (T) to secure panel (A1) to panel (A) and leg (B). Do not try over tighten, this may break the cam lock.

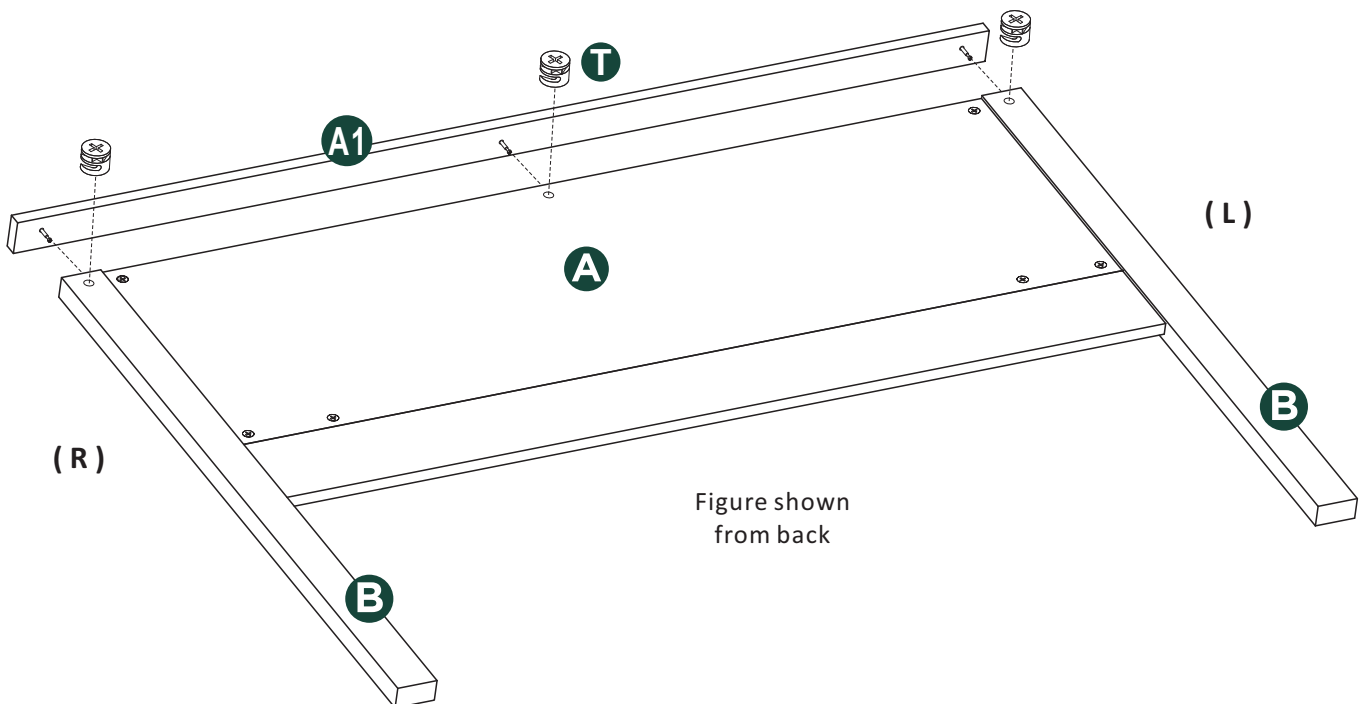

5

Attach washer (O) to bolt (J). Thread (J) bolts into the holes in the leg (B).
Do not tighten. These will be tightened in later steps.

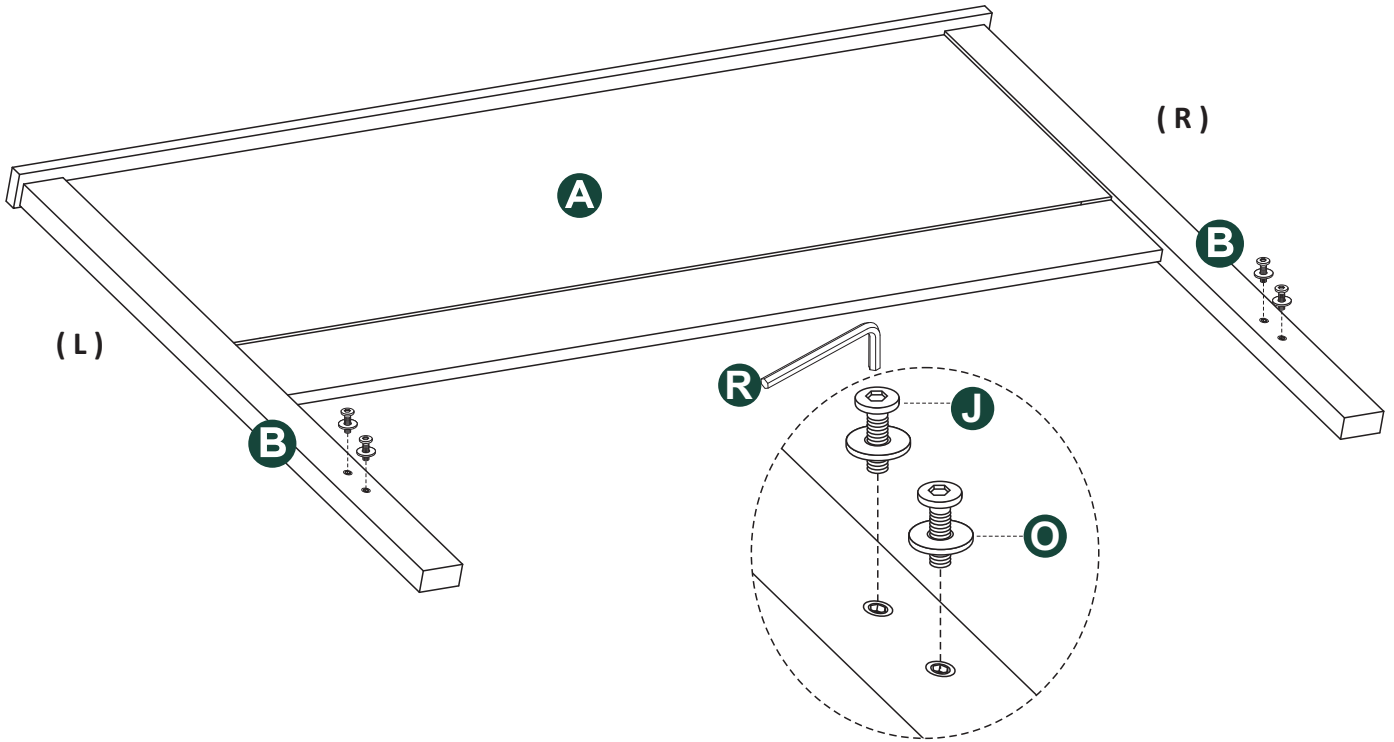
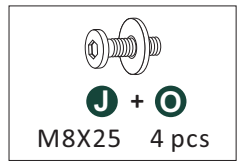
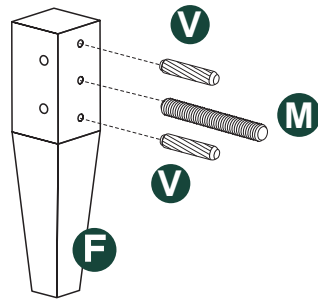
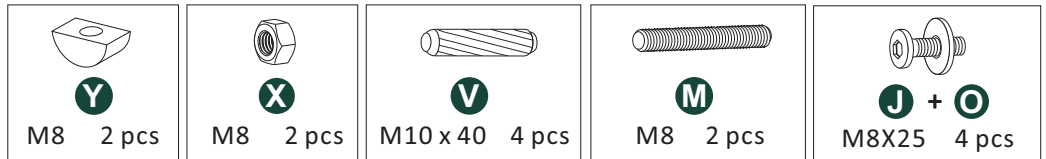
**6**

First, Insert wooden dowel (V) and thread (M) bolt by hand into both foot legs (F).

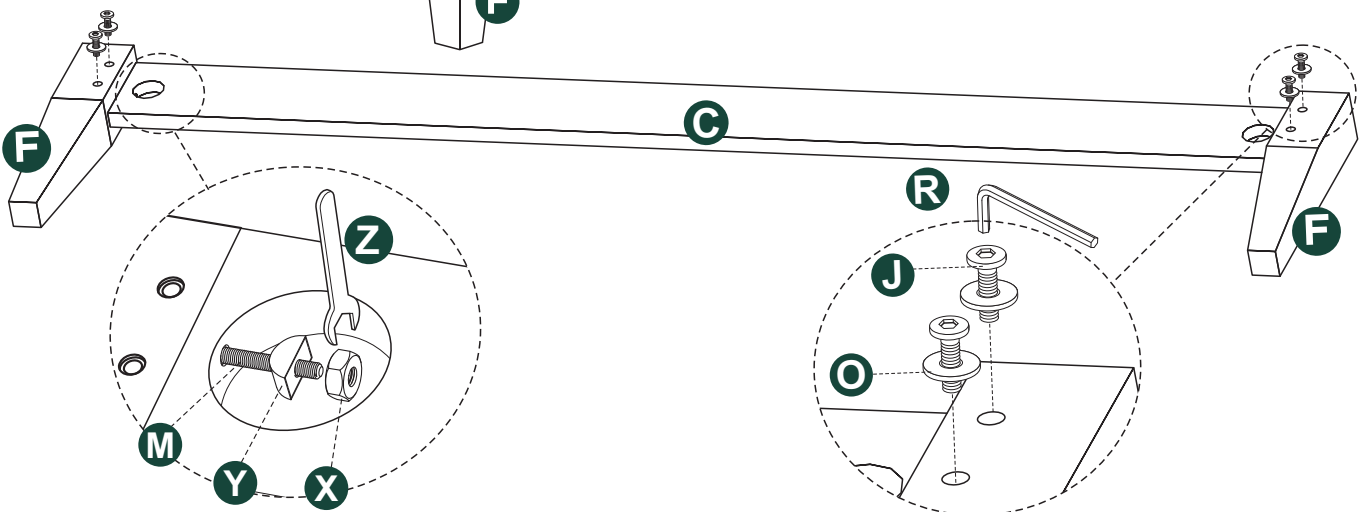

Then insert both foot legs to ends of panel (C). Attach washer (Y) and nut (X) to the bolt (M) to connect foot legs to panel (C). Tighten with wrench (Z).

Finally, attach washer (O) to bolt (J). Thread (J) bolts into the holes in the leg (F). Do not tighten. These will be tightened in later steps.

7

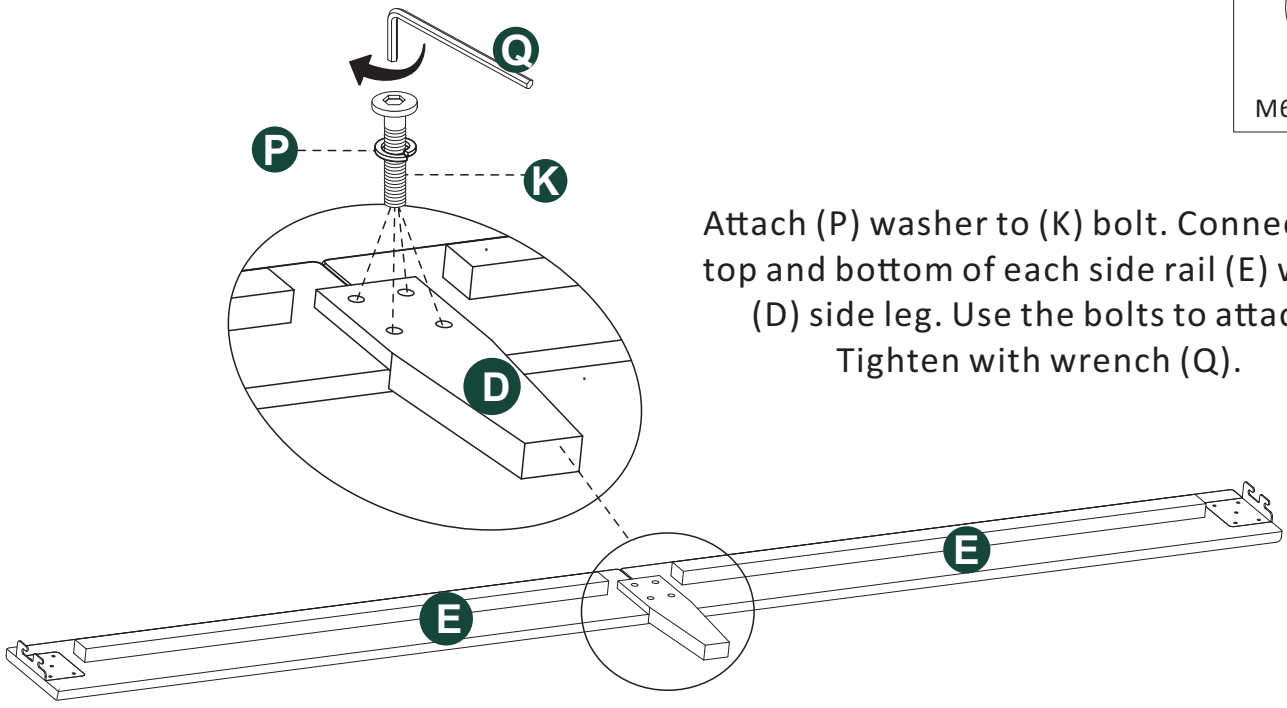
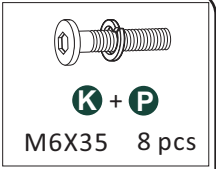

Attach (P) washer to (K) bolt. Connect the top and bottom of each side rail (E) with a (D) side leg. Use the bolts to attach. Tighten with wrench (Q).

Repeat steps to assemble right side rail.

8

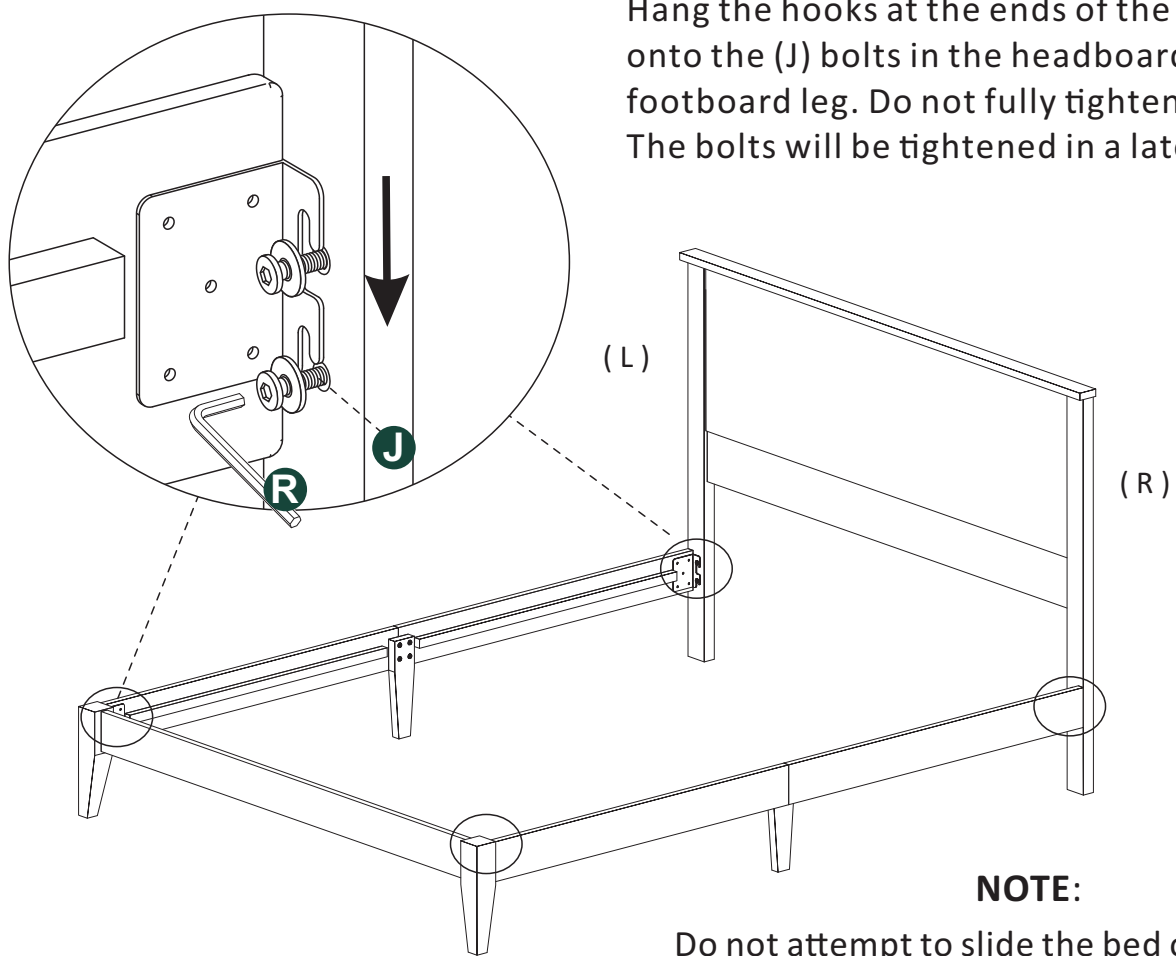

Hang the hooks at the ends of the side rails onto the (J) bolts in the headboard leg and the footboard leg. Do not fully tighten the (J) bolts. The bolts will be tightened in a later step.

NOTE:

Do not attempt to slide the bed once it is fully assembled. Sliding the bed could result in damage to the rails, headboard, or footboard. Assembled bed should be lifted and carried when being moved (not slid).

First, place the slats roll into the frame of the bed, then extend the slats and velcro the slats to the cleat of side rail as shown below.

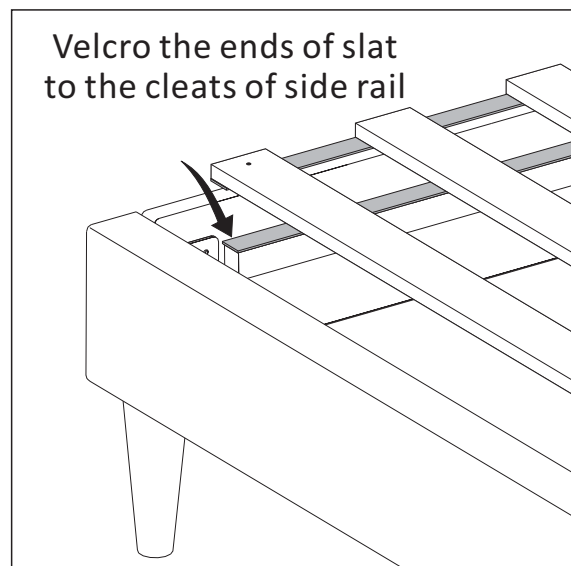
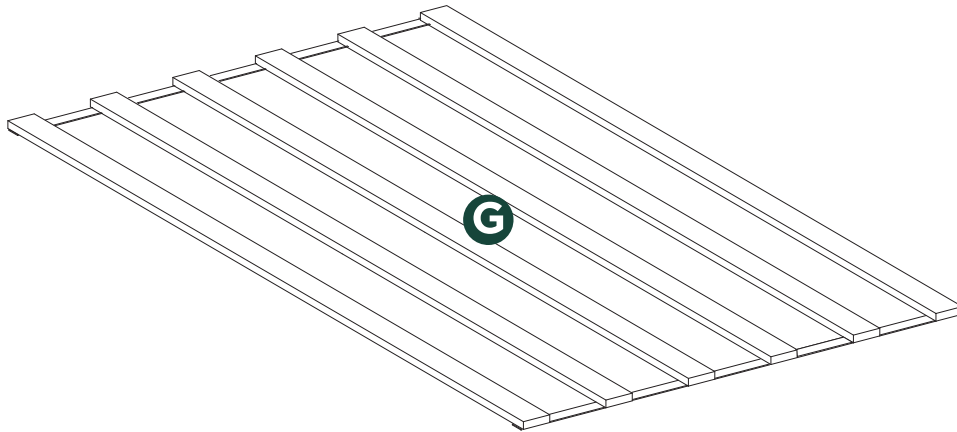

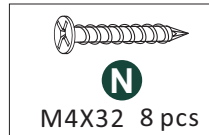
**NOTE:**

The center support leg glide sits approximately 1/4" off of the floor. The glide will usually touch the floor after a mattress is placed on the bedframe.

Do not place a mattress on bedframe until it is fully assembled and tightened. The bedframe should be located in your desired location. Sliding the bed with weight upon it can compromise the integrity of the center support legs.

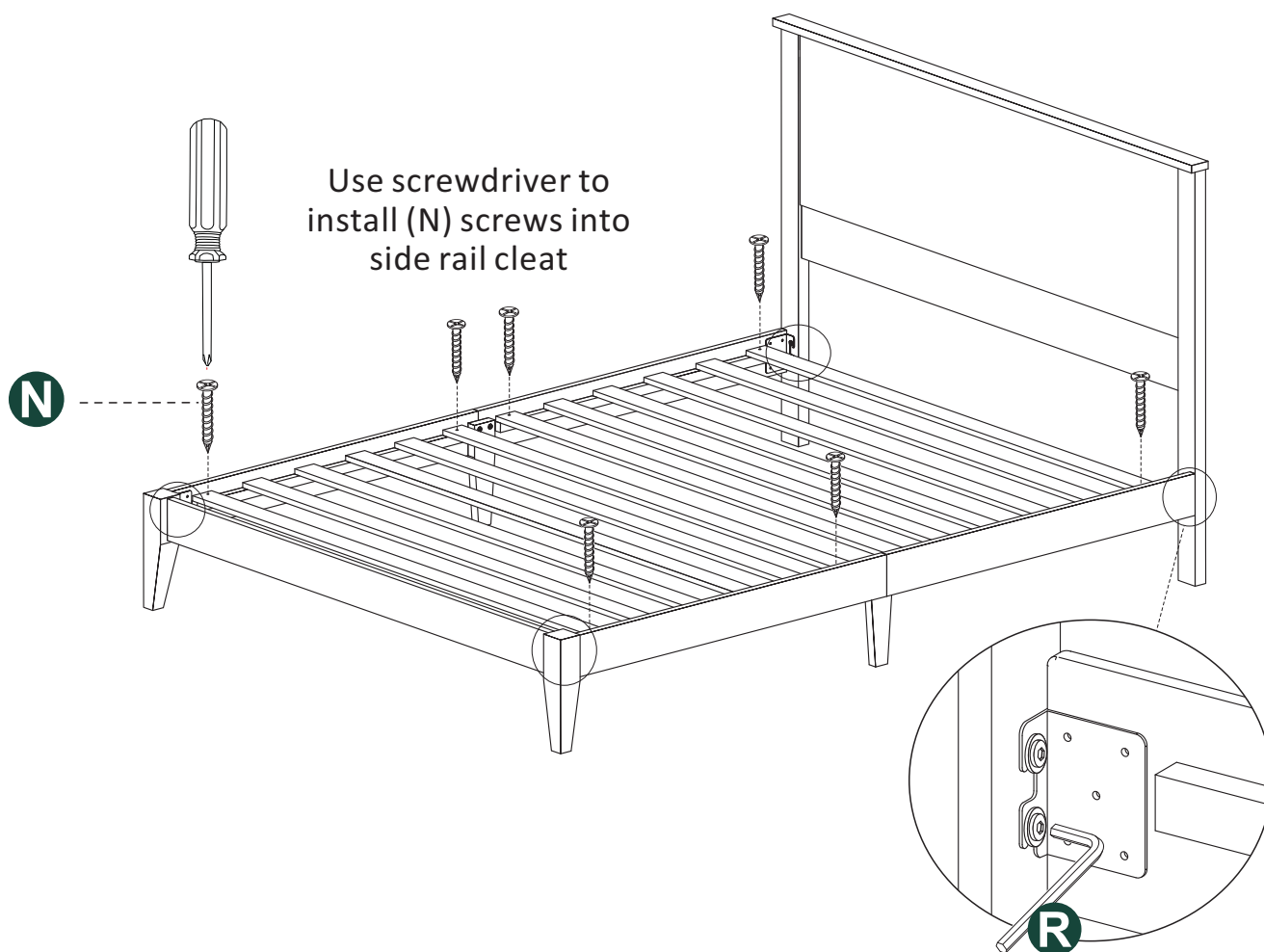
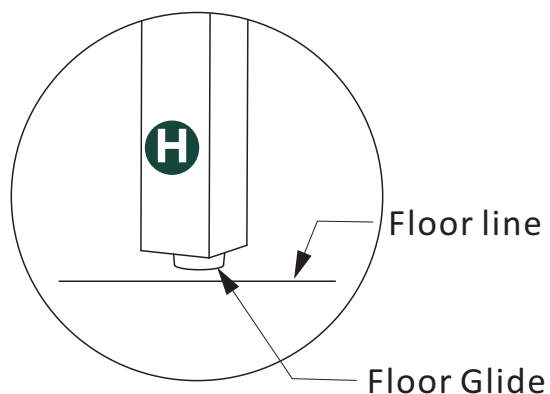

Finally, tighten all (J) bolts, tighten with wrench (R).

You're all finished! Sweet dreams!

CAUTION:

DO NOT SLIDE BED; PICK BED UP TO REPOSITION/LOCATE IT UPON COMPLETING ASSEMBLY

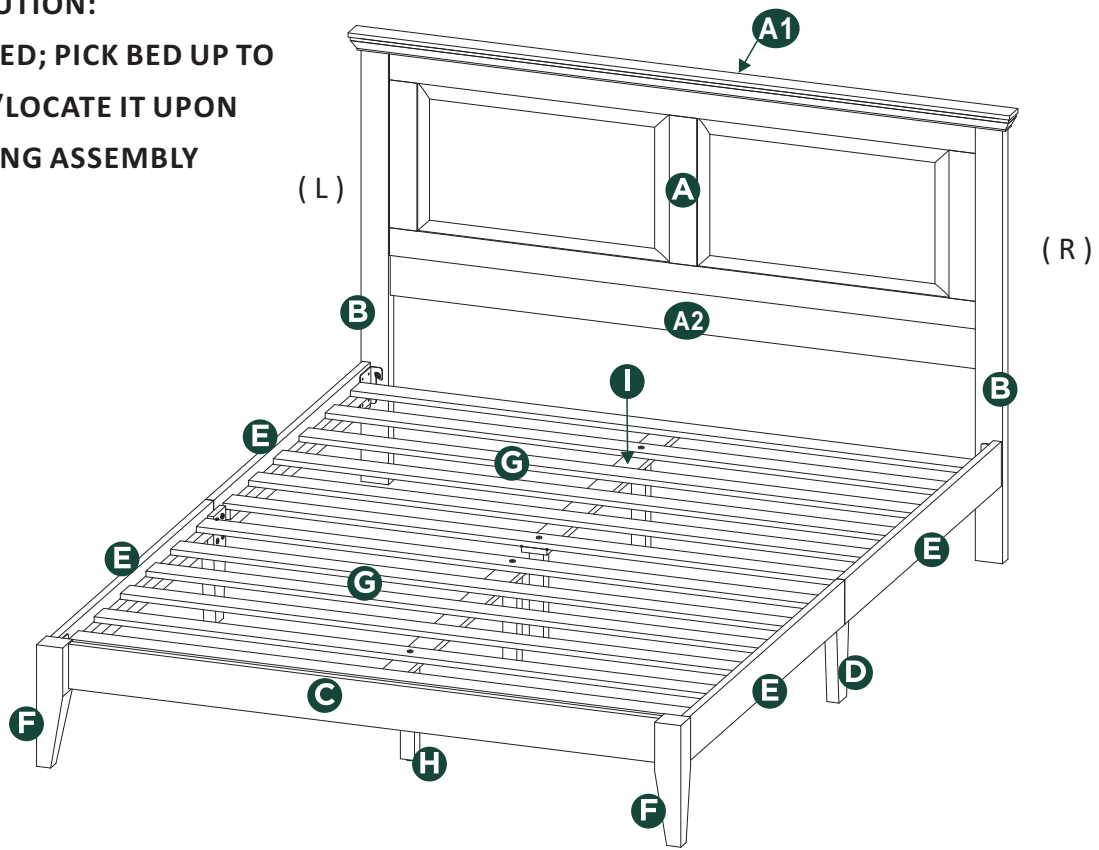

Revision Number: 01

52014 Queen Bed/ Full Bed

E1220140, E1220147, E1220154, E1220161
E1220168, E1220175, E1220182, E1220189

Components

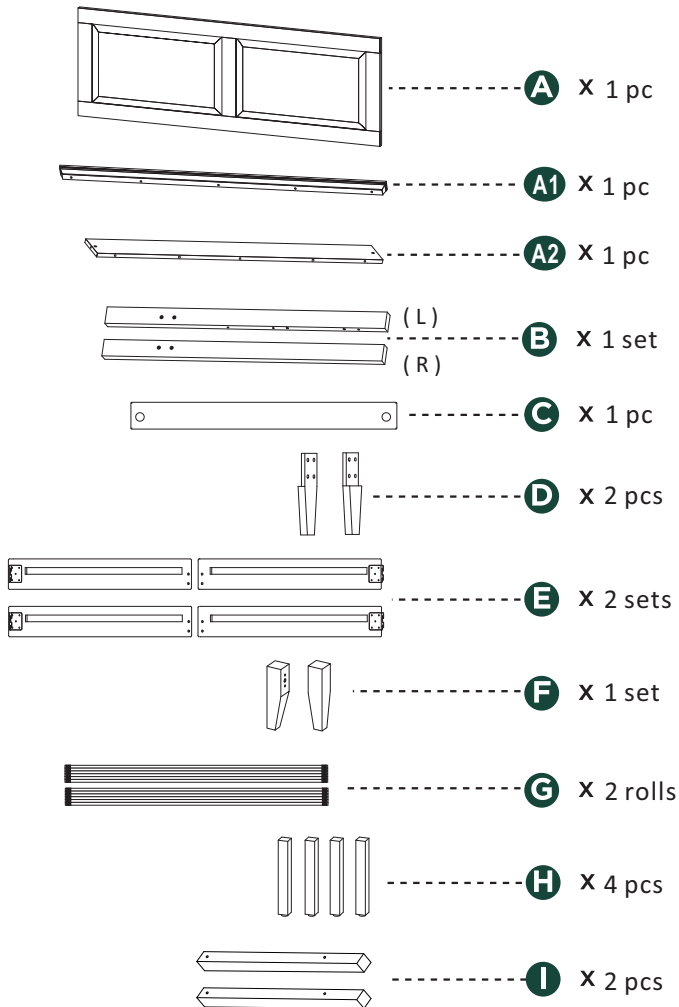

Hardware

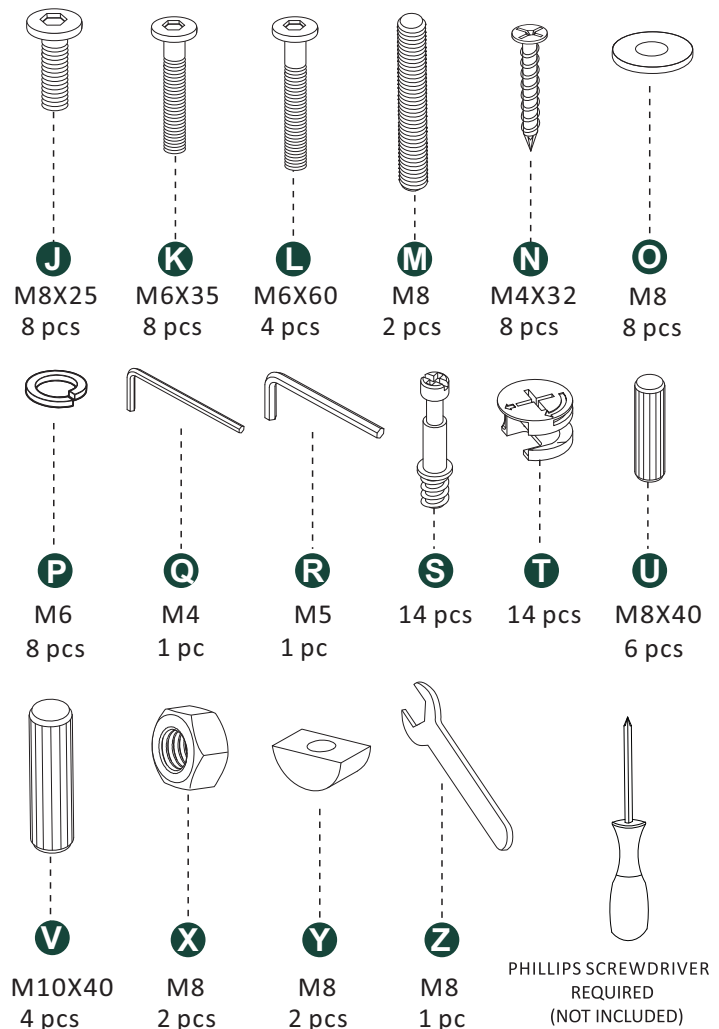

CAUTION:

Do not attempt to slide the bed once it is fully assembled. To avoid structural damage while moving your assembled bed, any mattress and bedding should be removed from the bedframe. Then the bedframe should be lifted and carried (not slid) to your desired location.

When placing furniture on non-carpeted flooring, we recommend the use of floor protection such as an area rug or furniture pads. Area rugs and padding not included with purchase.

Max Weight Limit 600lbs.

When using an adjustable base please use the legs provided with the adjustable base for maximum support.

Using zero clearance adjustable bases without legs directly on the slats is NOT recommended and will void your warranty.

1

Use screwdriver to thread cam bolts (S) to panel (A1), (A2), and leg (B). Insert wooden dowel (U) to leg (B) and panel (A2) as shown below.

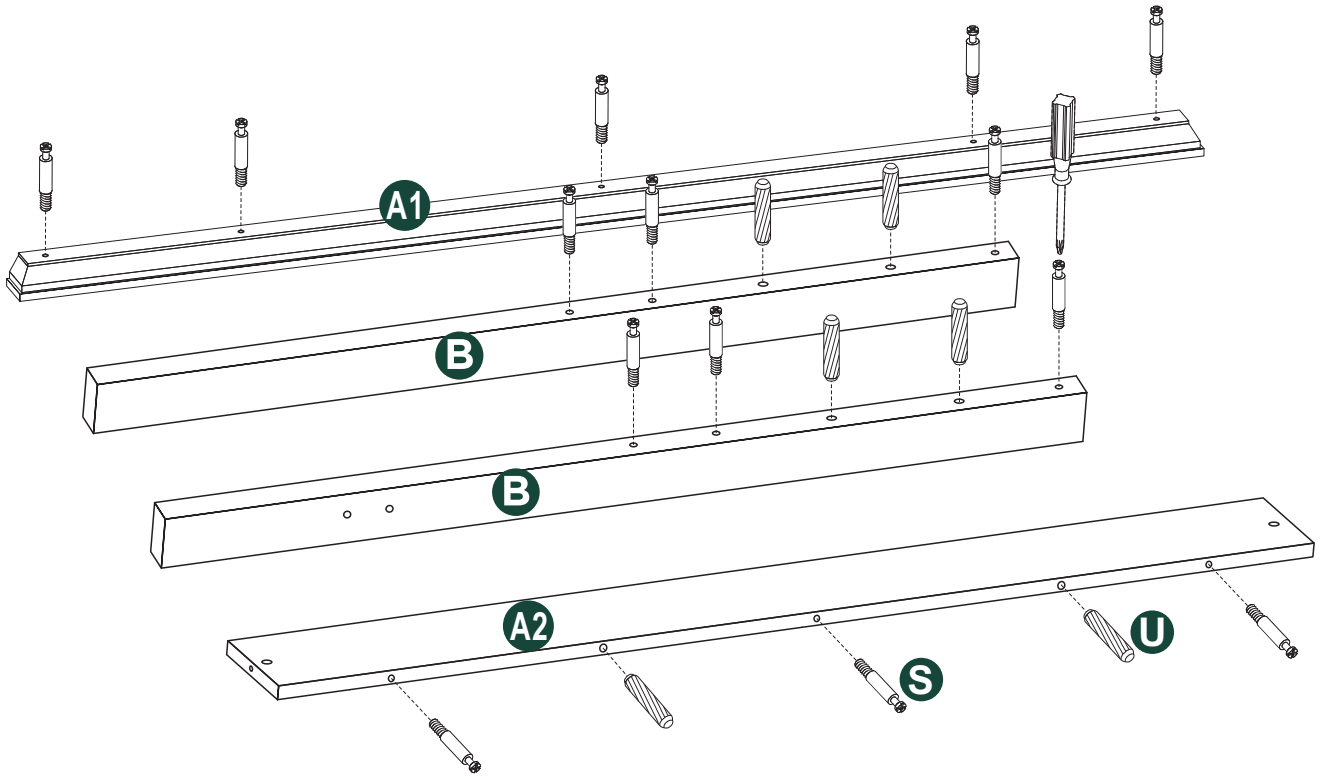
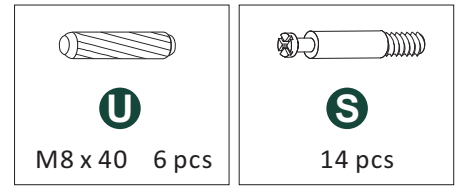
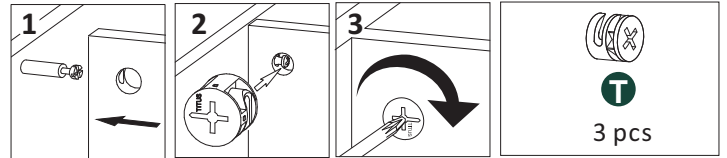
**2**

Insert panel (A2) to panel (A). Insert cam lock (T) to the holes of panel (A) as shown below. Use screwdriver to turn cam lock (T) to secure panel (A2) to panel (A). Do not try over tighten, this may break the cam lock.

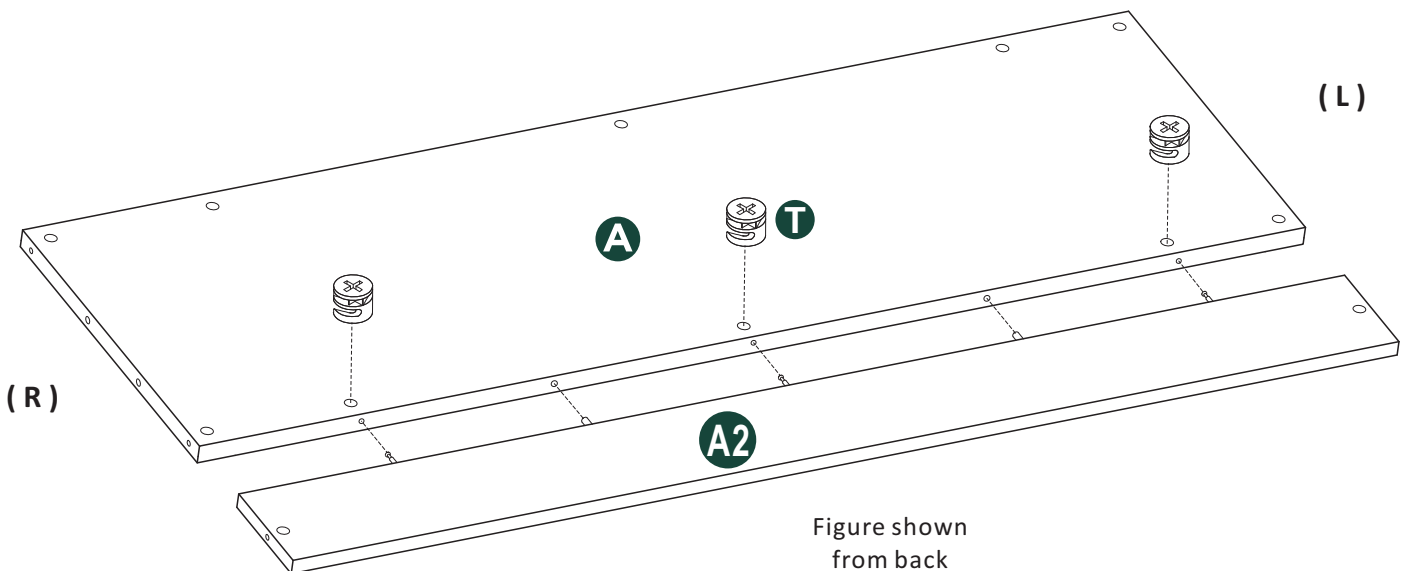

3

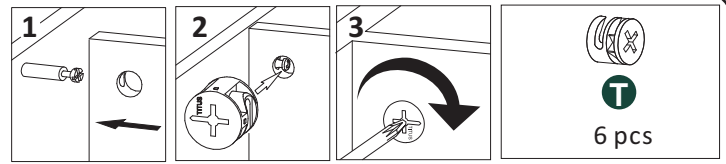

Insert leg (B) to end of panel (A) and (A2). Insert cam lock (T) to the holes of panel (A) and (A2) as shown below. Use screwdriver to turn cam lock (T) to secure leg (B) to panel (A) and (A2). Do not try over tighten, this may break the cam lock.

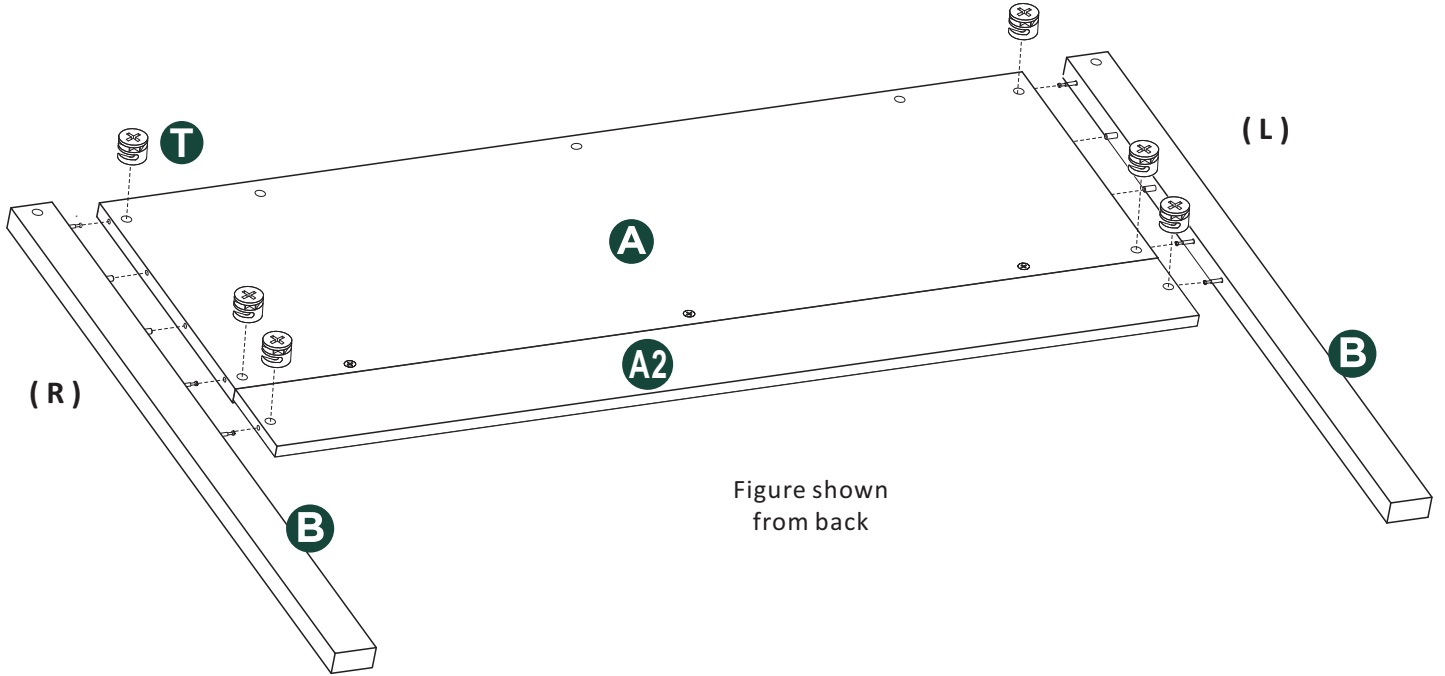

4

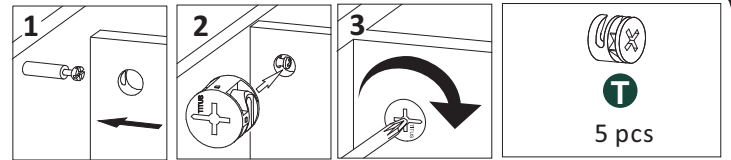

Insert panel (A1) to top end of panel (A) and leg (B). Insert cam lock (T) to the holes of panel (A) and leg (B) as shown below. Use screwdriver to turn cam lock (T) to secure panel (A1) to panel (A) and leg (B). Do not try over tighten, this may break the cam lock.

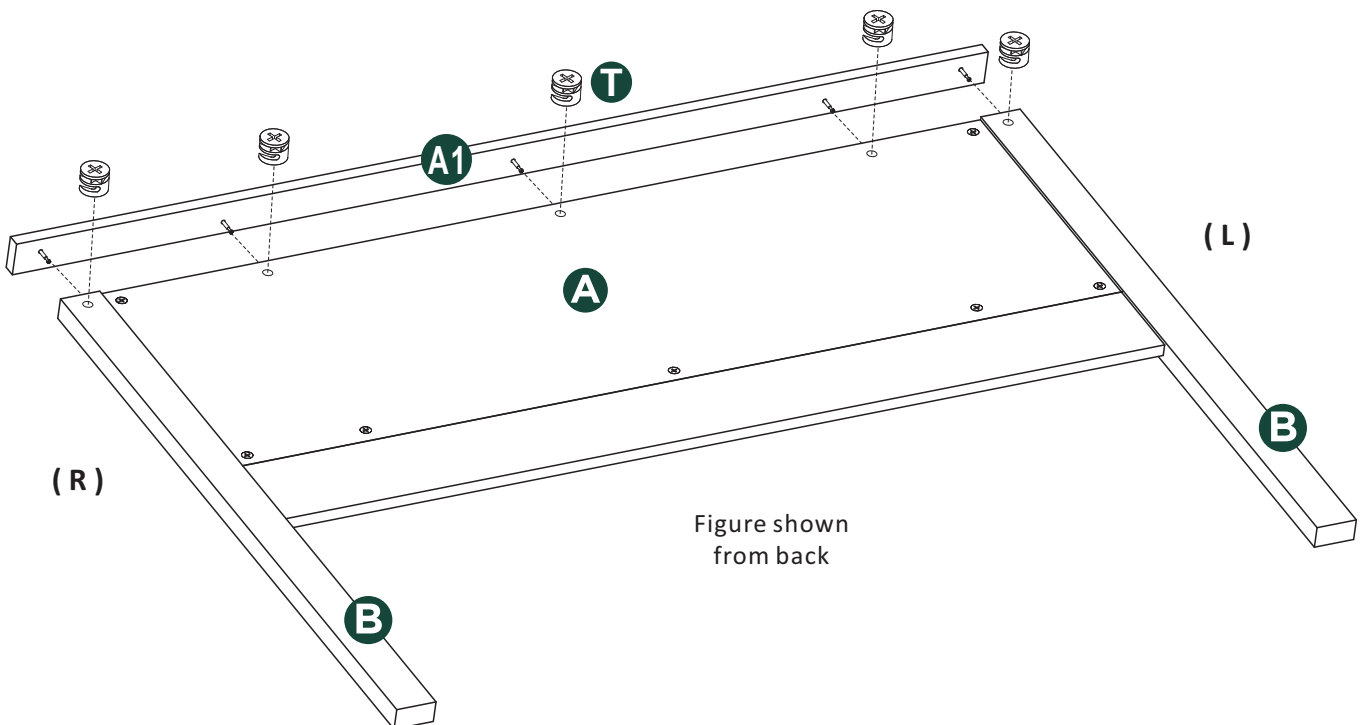

5

Attach washer (O) to bolt (J). Thread (J) bolts into the holes in the leg (B). Do not tighten. These will be tightened in later steps.

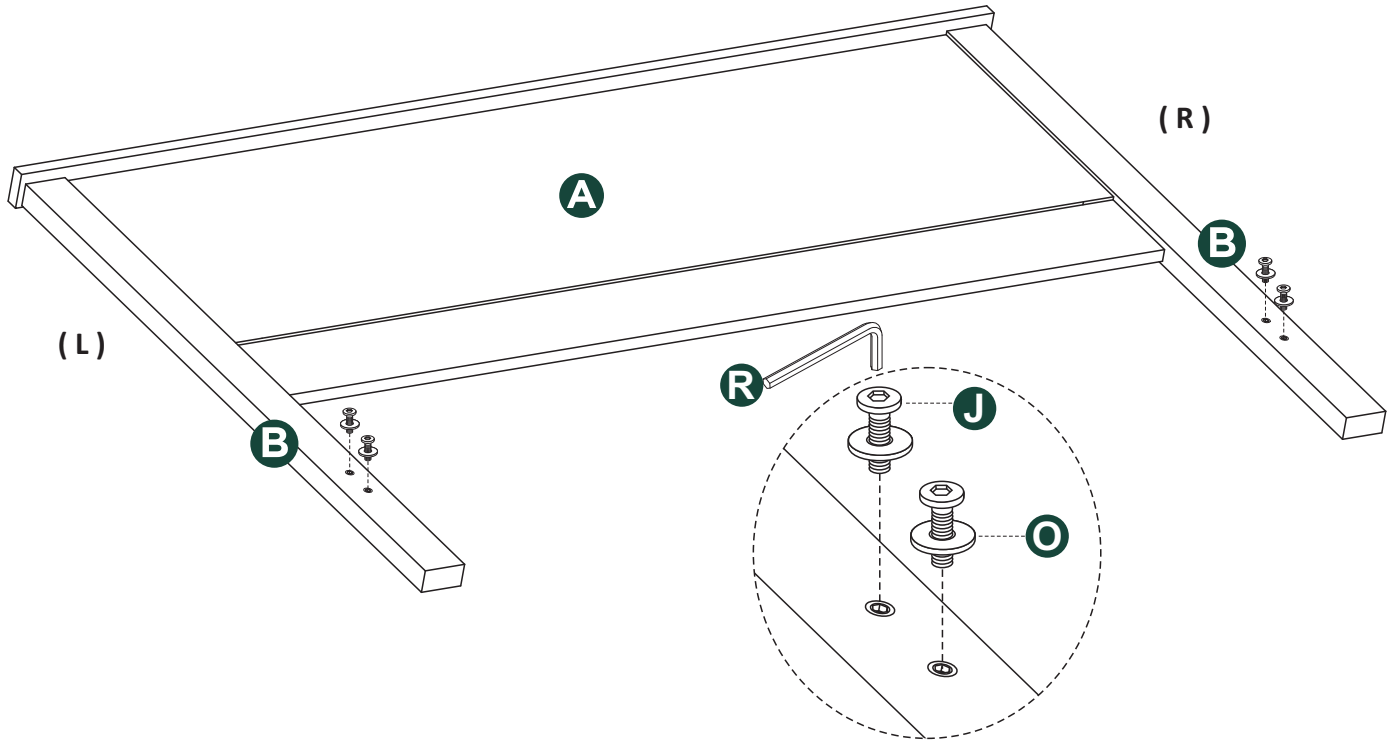
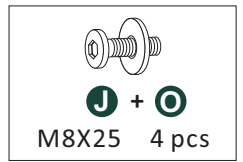
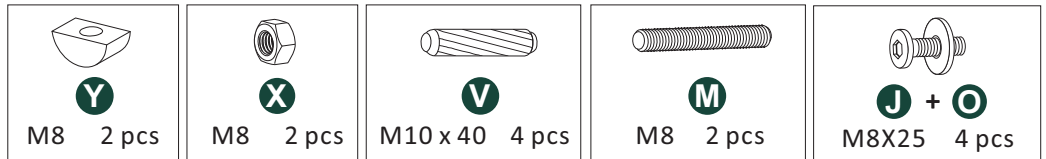
**6**

First, Insert wooden dowel (V) and thread (M) bolt by hand into both foot legs (F).

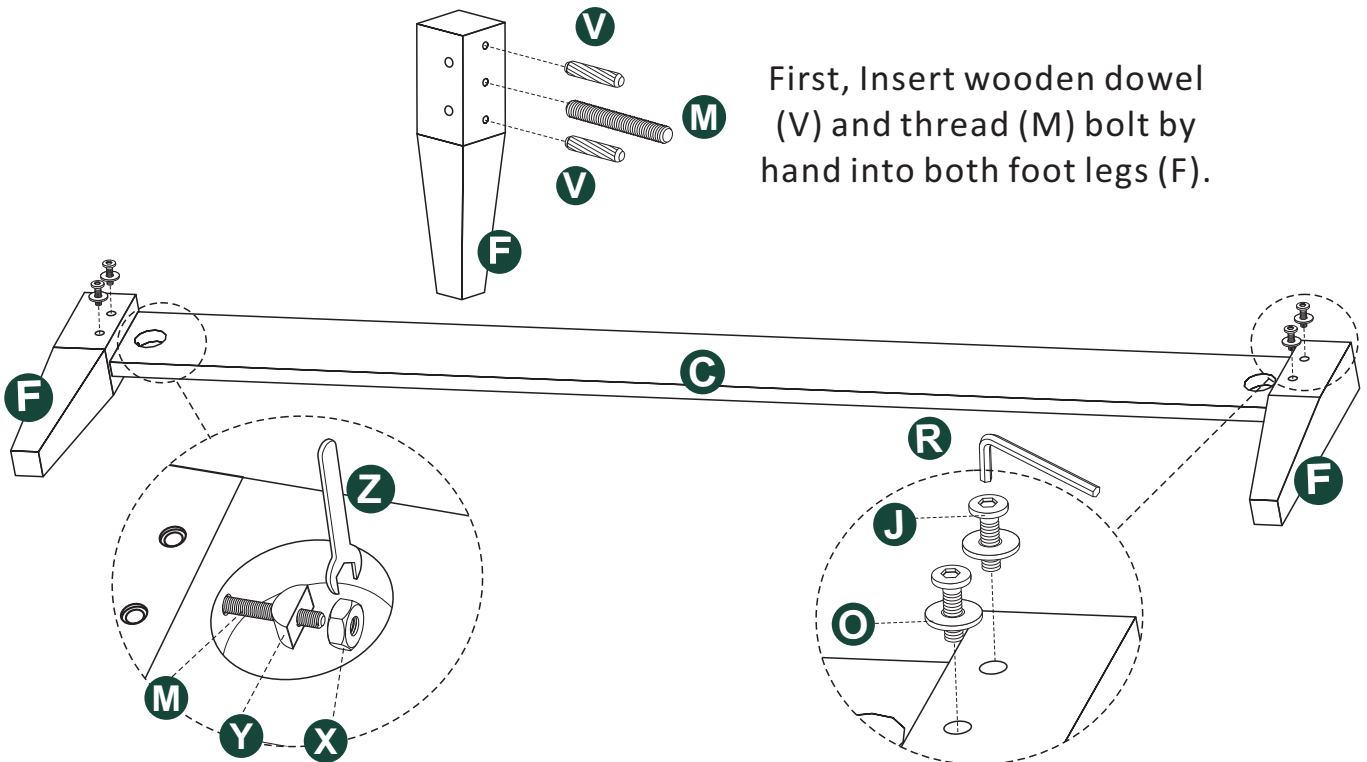

Then insert both foot legs to ends of panel (C). Attach washer (Y) and nut (X) to the bolt (M) to connect foot legs to panel (C). Tighten with wrench (Z).

Finally, attach washer (O) to bolt (J). Thread (J) bolts into the holes in the leg (F). Do not tighten. These will be tightened in later steps.

7

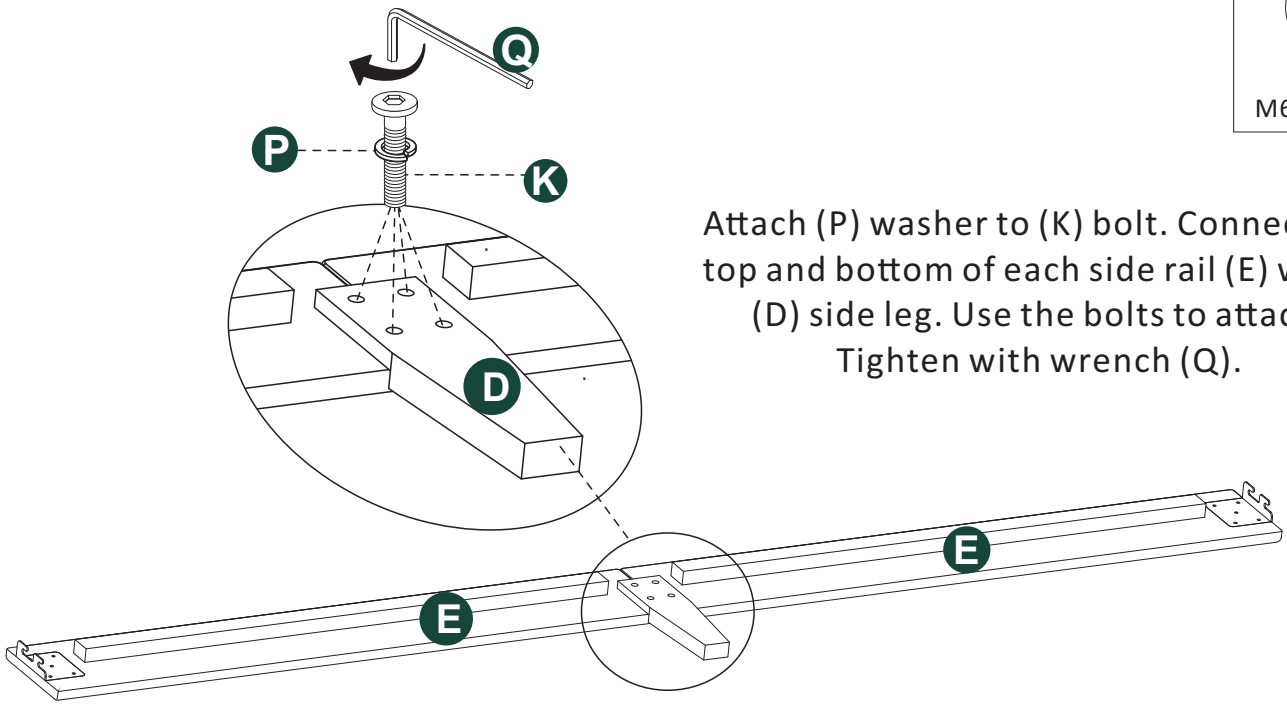
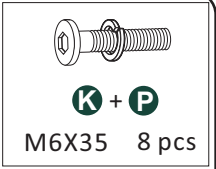

Attach (P) washer to (K) bolt. Connect the top and bottom of each side rail (E) with a (D) side leg. Use the bolts to attach. Tighten with wrench (Q).

Repeat steps to assemble right side rail.

8

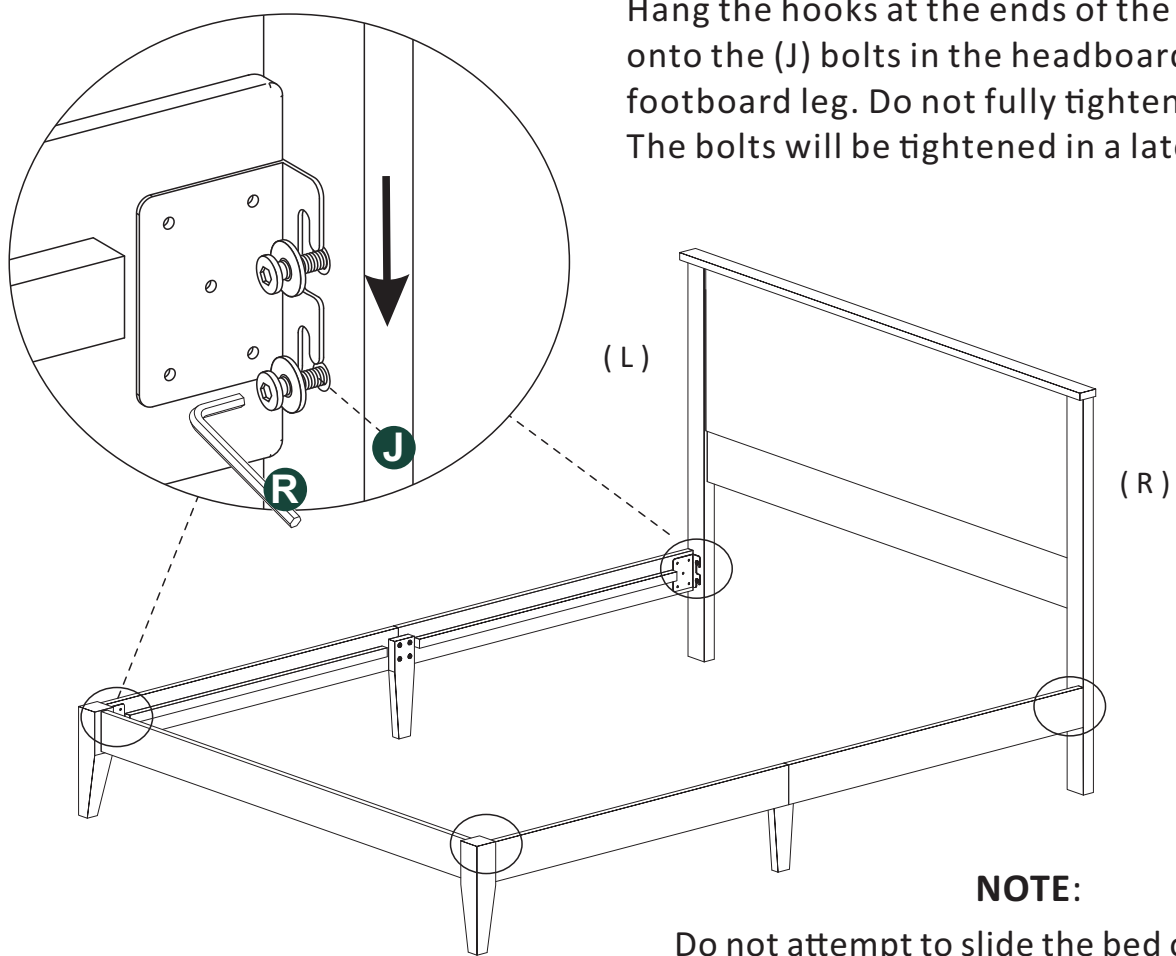

Hang the hooks at the ends of the side rails onto the (J) bolts in the headboard leg and the footboard leg. Do not fully tighten the (J) bolts. The bolts will be tightened in a later step.

NOTE:

Do not attempt to slide the bed once it is fully assembled. Sliding the bed could result in damage to the rails, headboard, or footboard. Assembled bed should be lifted and carried when being moved (not slid).

9

Assemble the slat system by attaching the slats to the (I) supports and (H) legs. First, extend the slats. Then, line up the holes in the slats with the holes in the (I) supports and the holes in the tops of the (H) legs. Use an (L) bolt through the holes to attach them together. Tighten with wrench (Q).

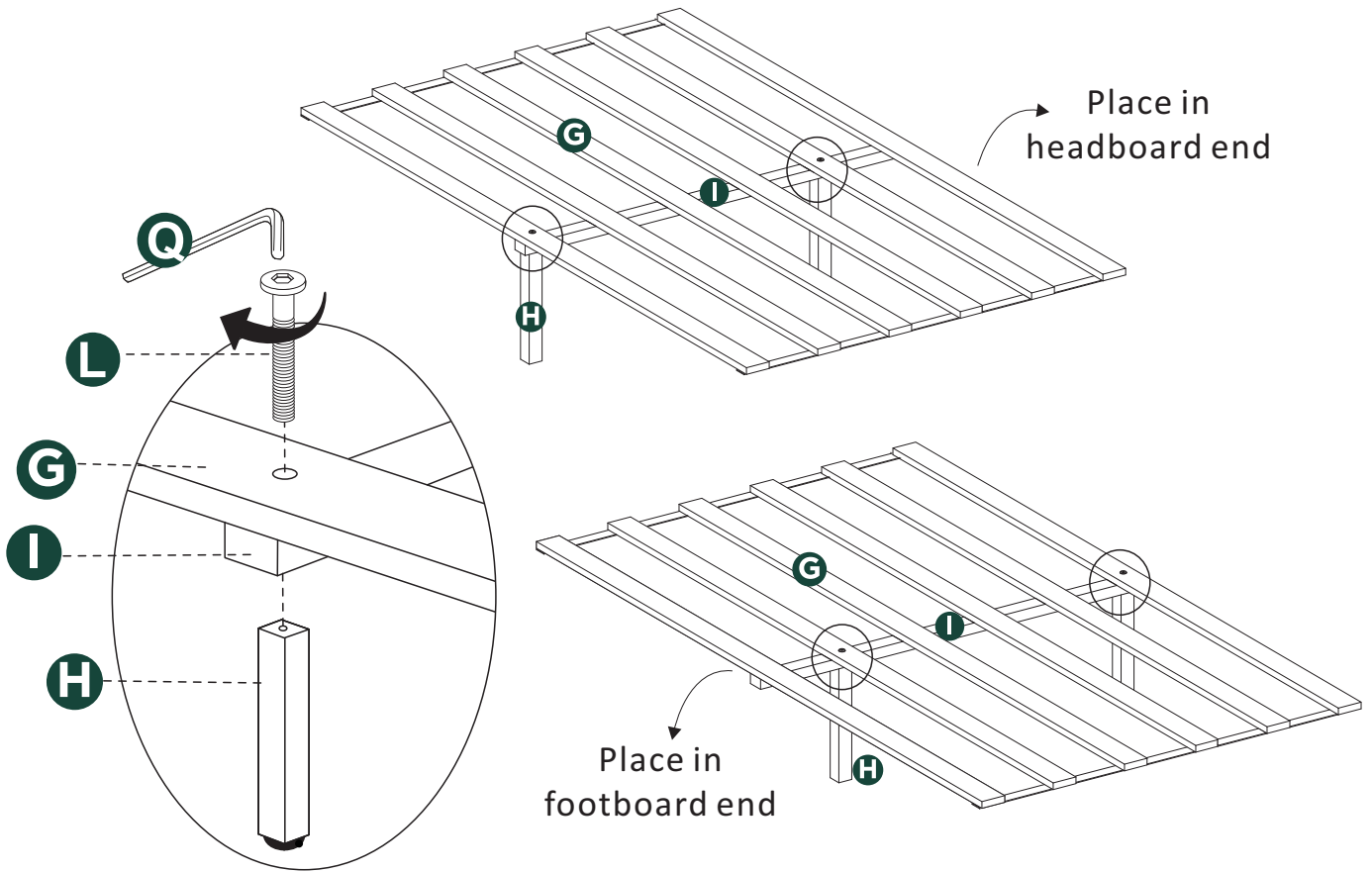
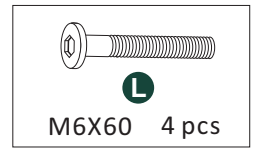

After the slat system is assembled, place the slats into the frame of the bed as shown, and velcro the slats to the cleat of side rail as shown below.

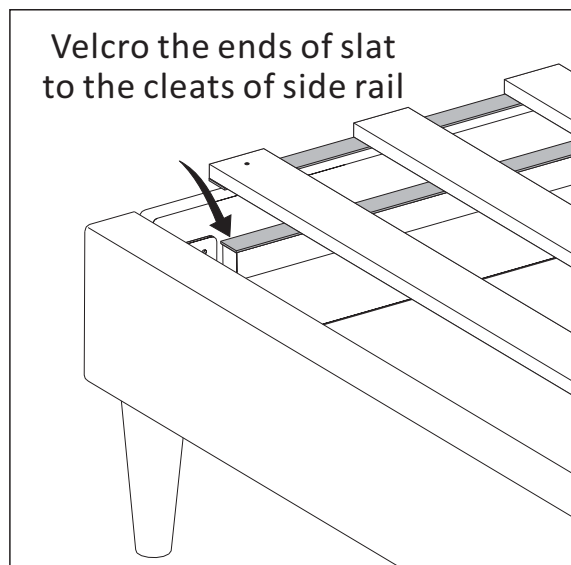

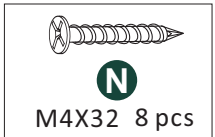

NOTE:

The center support leg glide sits approximately 1/4" off of the floor. The glide will usually touch the floor after a mattress is placed on the bedframe.

Do not place a mattress on bedframe until it is fully assembled and tightened. The bedframe should be located in your desired location. Sliding the bed with weight upon it can compromise the integrity of the center support legs.

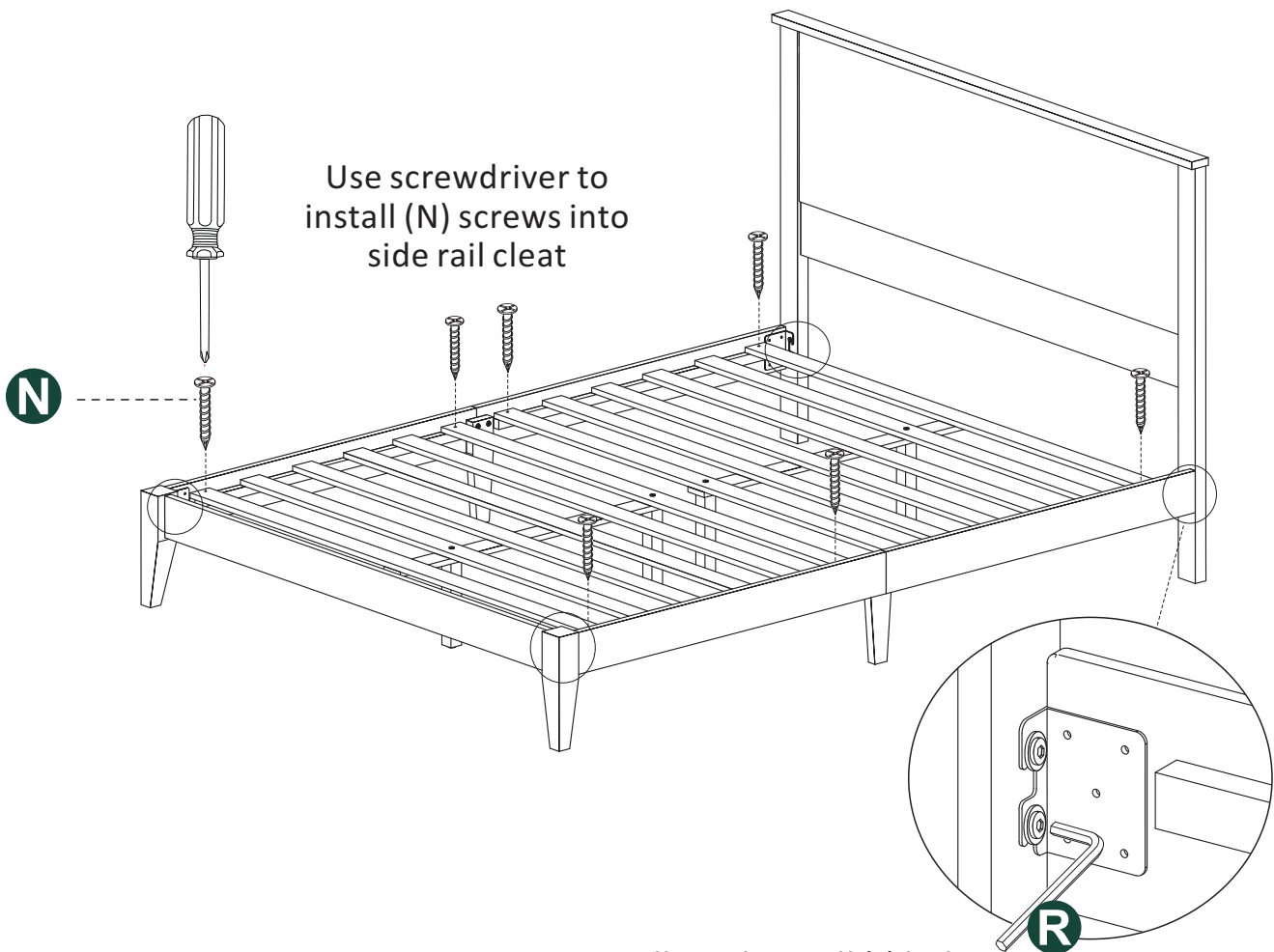
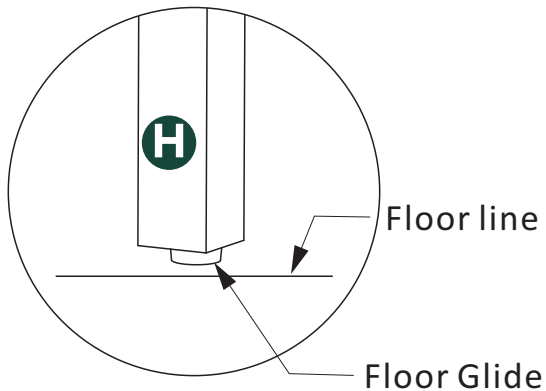

Finally, tighten all (J) bolts, tighten with wrench (R).

You're all finished! Sweet dreams!

CAUTION:

DO NOT SLIDE BED; PICK BED UP TO REPOSITION/LOCATE IT UPON COMPLETING ASSEMBLY

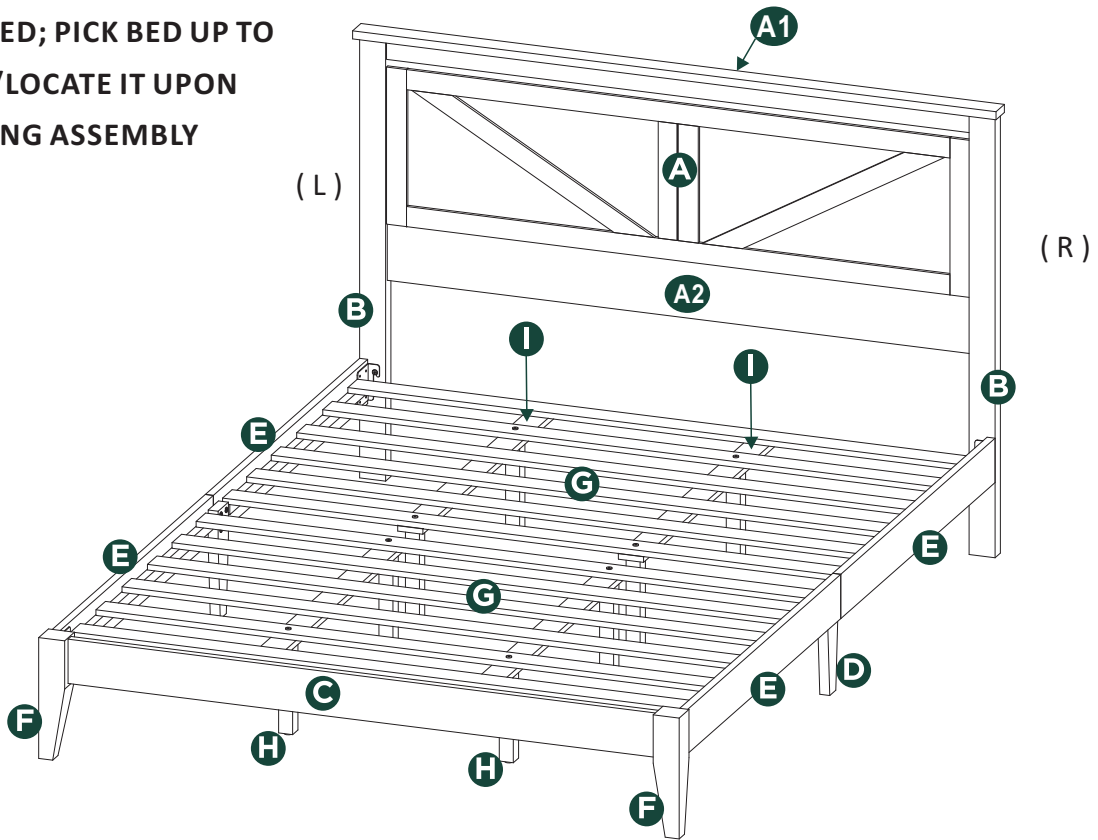

Revision Number: 01

52013 King Bed

E1220000, E1220007, E1220014, E1220021

Components

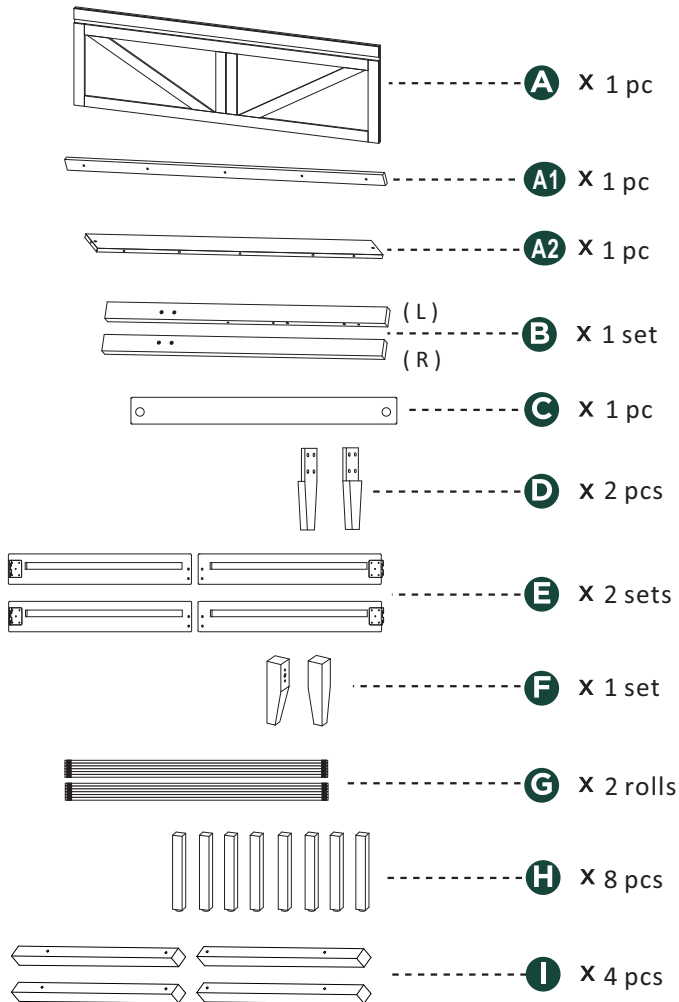

Hardware

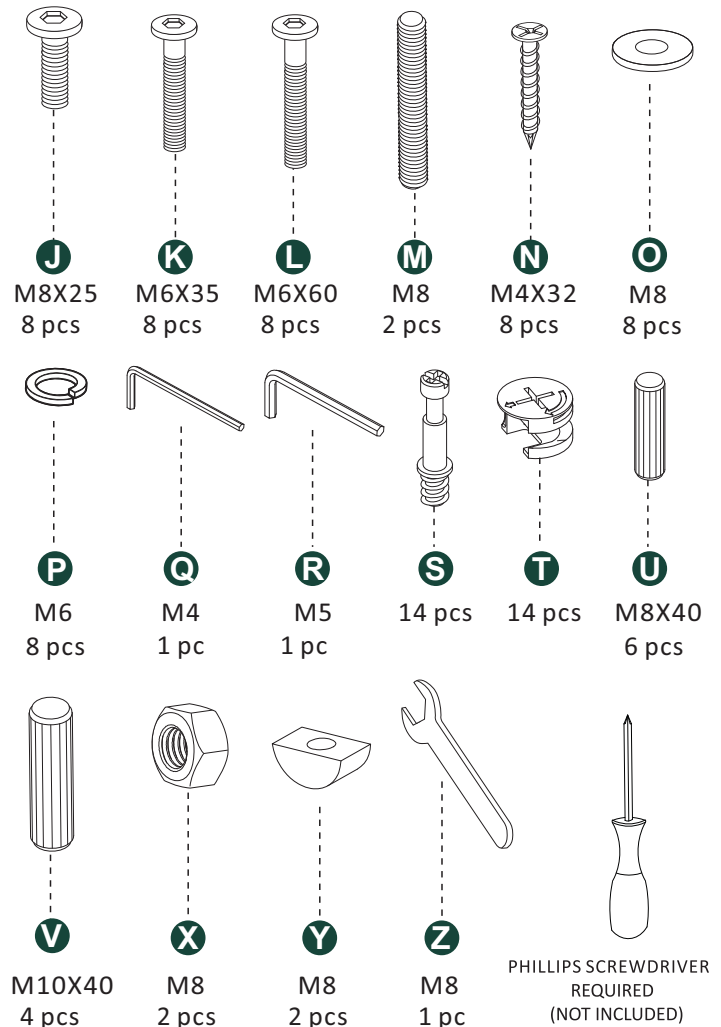

CAUTION:

Do not attempt to slide the bed once it is fully assembled. To avoid structural damage while moving your assembled bed, any mattress and bedding should be removed from the bedframe. Then the bedframe should be lifted and carried (not slid) to your desired location.

When placing furniture on non-carpeted flooring, we recommend the use of floor protection such as an area rug or furniture pads. Area rugs and padding not included with purchase.

Max Weight Limit 600lbs.

When using an adjustable base please use the legs provided with the adjustable base for maximum support.

Using zero clearance adjustable bases without legs directly on the slats is NOT recommended and will void your warranty.

1

Use screwdriver to thread cam bolts (S) to panel (A1), (A2), and leg (B). Insert wooden dowel (U) to leg (B) and panel (A2) as shown below.

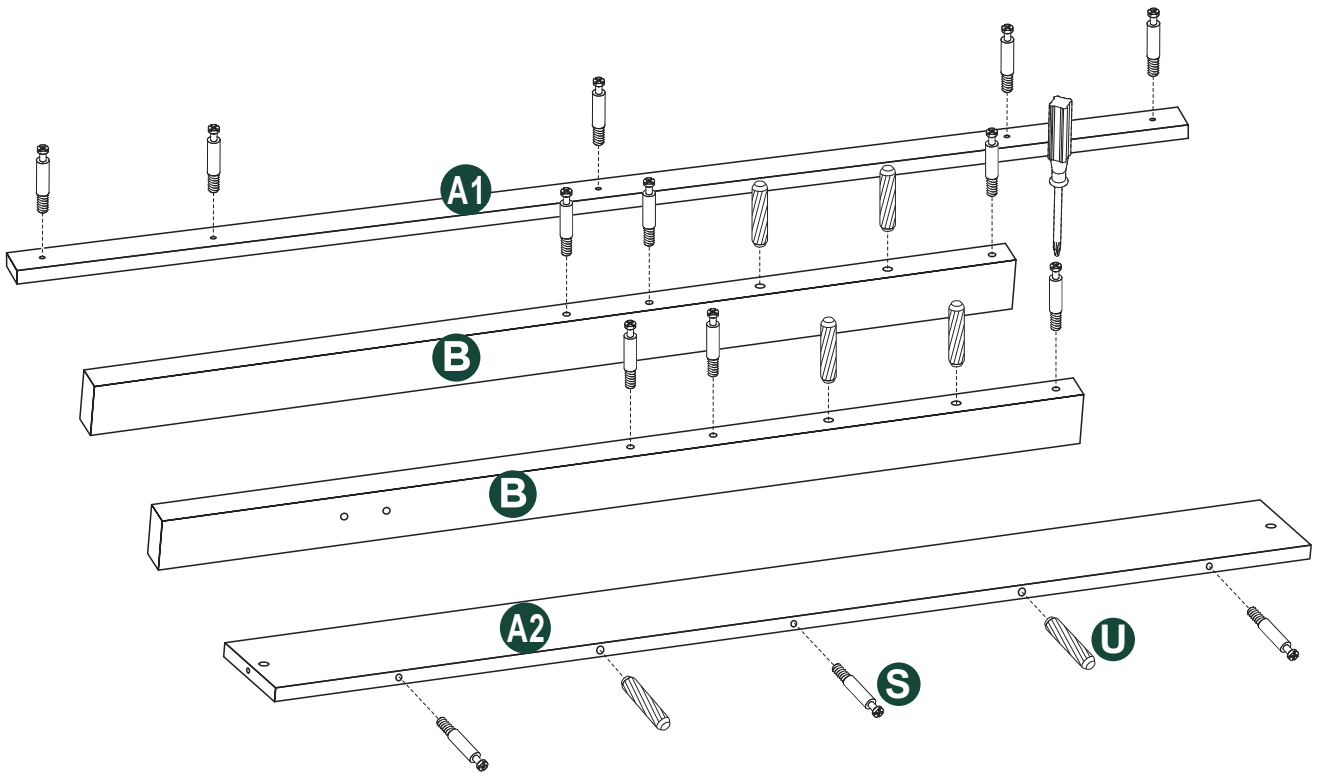
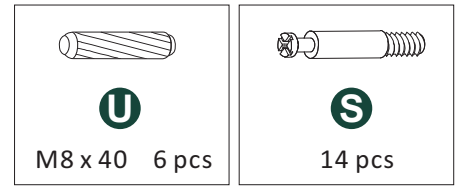
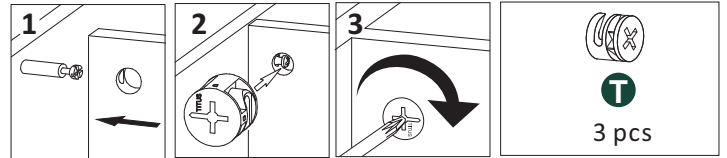
**2**

Insert panel (A2) to panel (A). Insert cam lock (T) to the holes of panel (A) as shown below. Use screwdriver to turn cam lock (T) to secure panel (A2) to panel (A).
Do not try over tighten, this may break the cam lock.

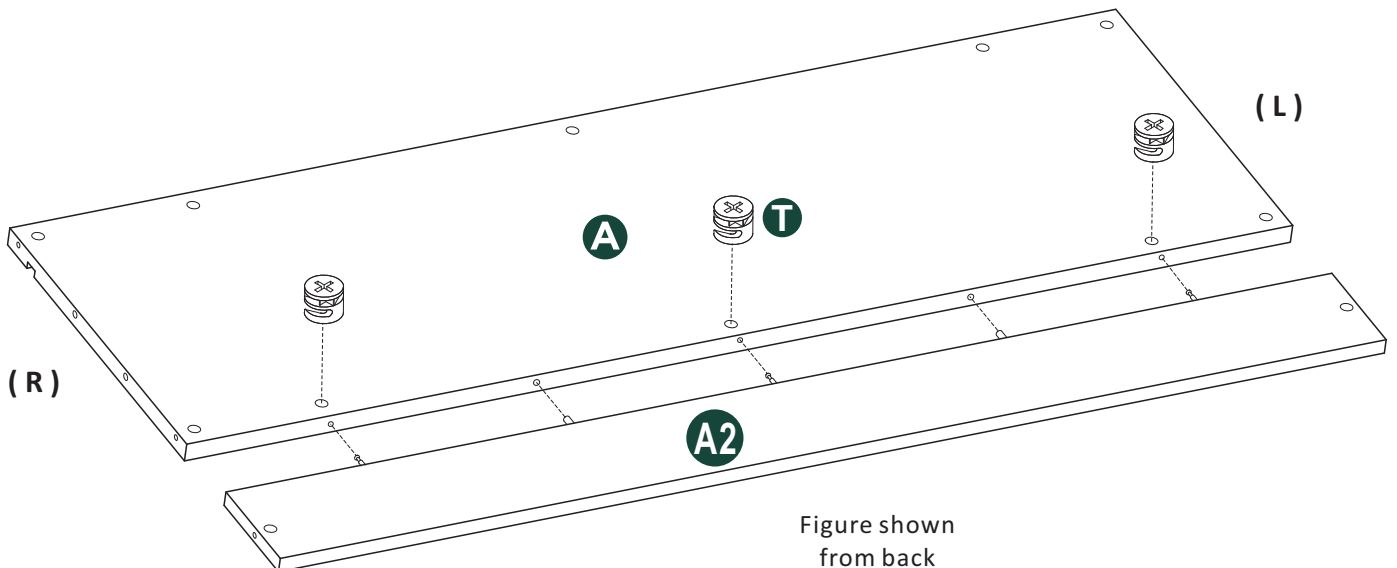

3

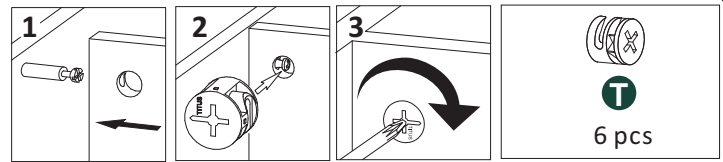

Insert leg (B) to end of panel (A) and (A2). Insert cam lock (T) to the holes of panel (A) and (A2) as shown below. Use screwdriver to turn cam lock (T) to secure leg (B) to panel (A) and (A2). Do not try over tighten, this may break the cam lock.

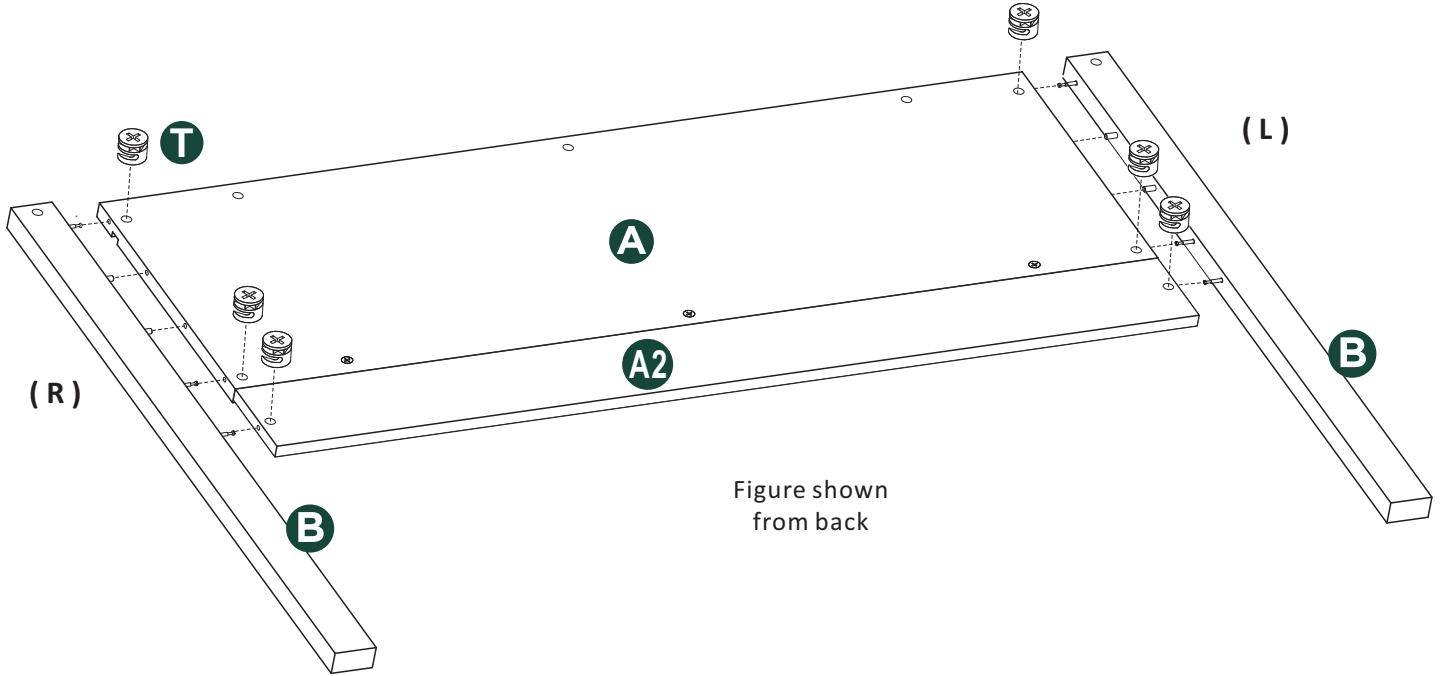
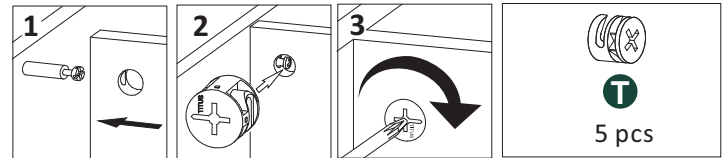

Figure shown from back

4



Insert panel (A1) to top end of panel (A) and leg (B). Insert cam lock (T) to the holes of panel (A) and leg (B) as shown below. Use screwdriver to turn cam lock (T) to secure panel (A1) to panel (A) and leg (B). Do not try over tighten, this may break the cam lock.

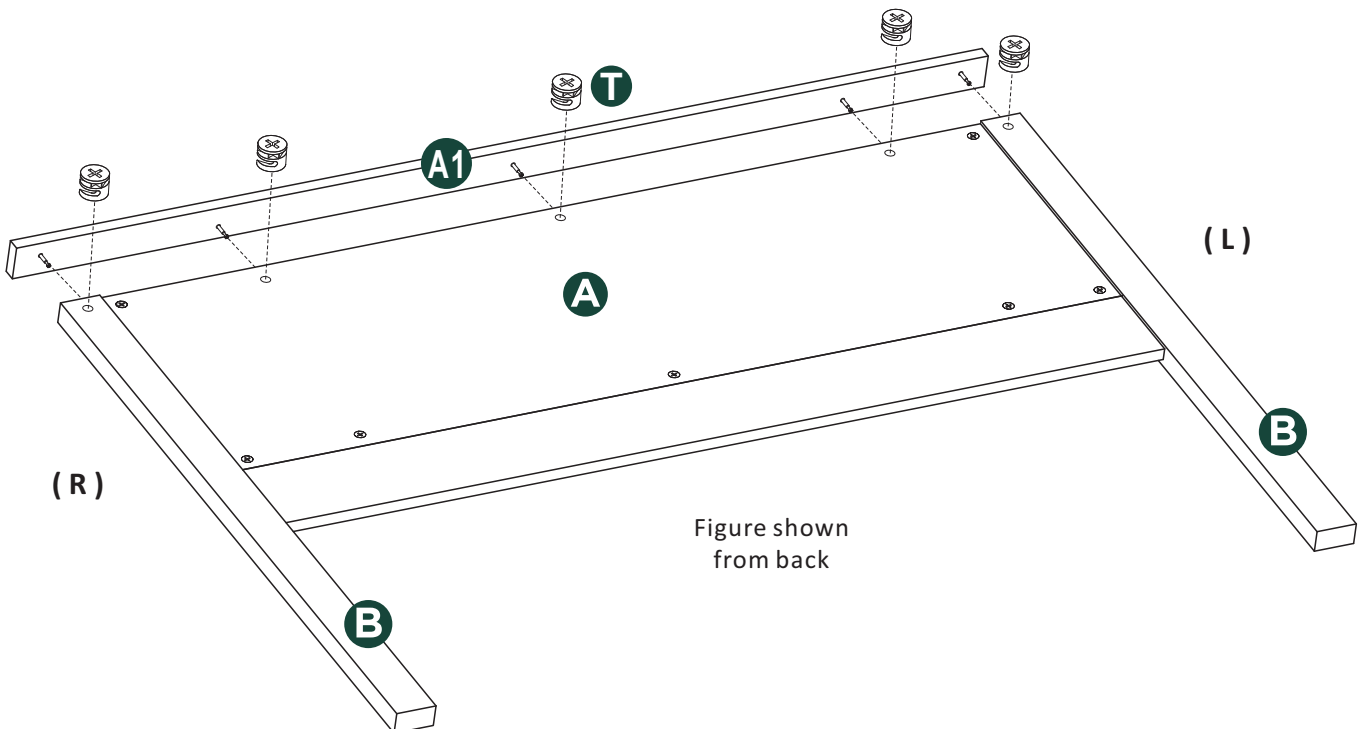
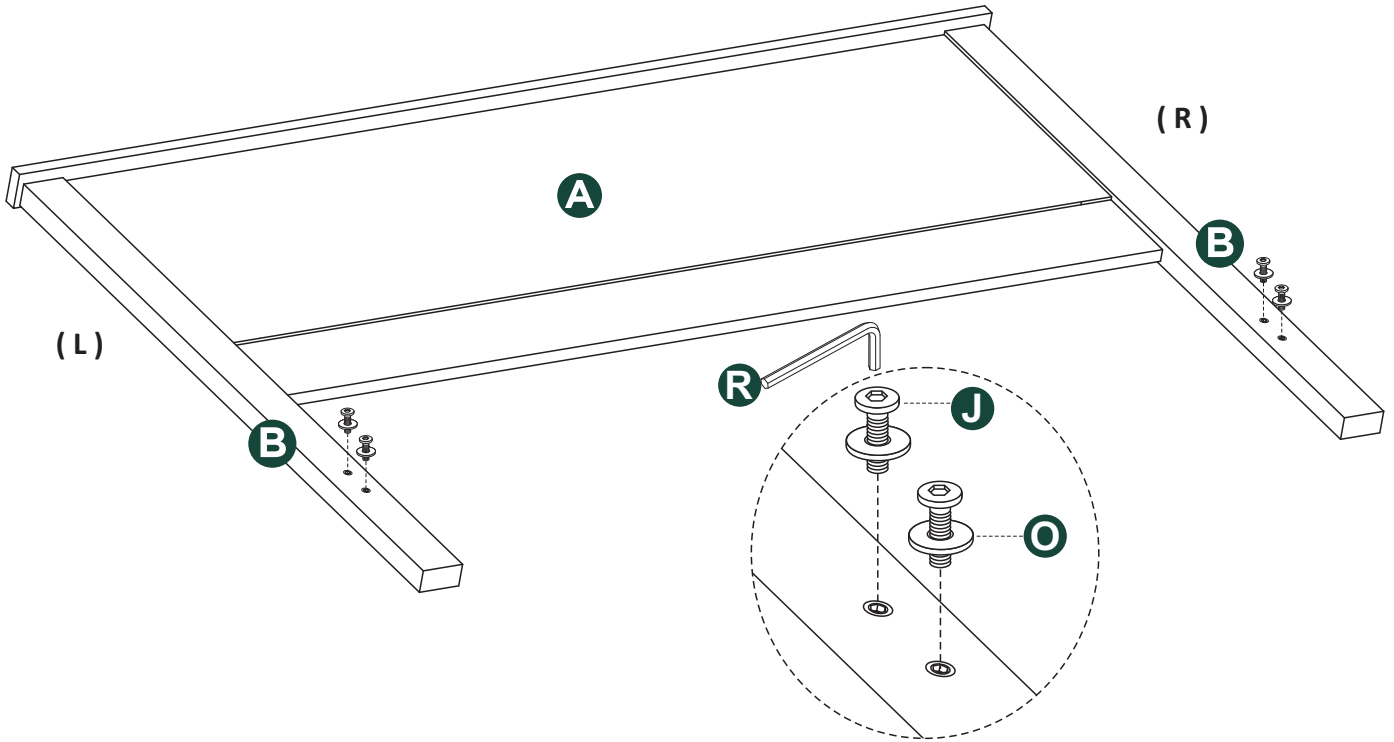
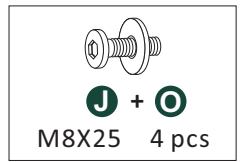
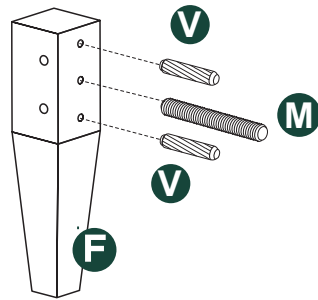
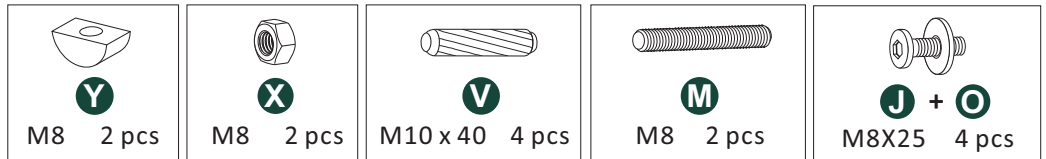

Figure shown from back

5

Attach washer (O) to bolt (J). Thread (J) bolts into the holes in the leg (B). Do not tighten. These will be tightened in later steps.

**6**

First, Insert wooden dowel (V) and thread (M) bolt by hand into both foot legs (F).

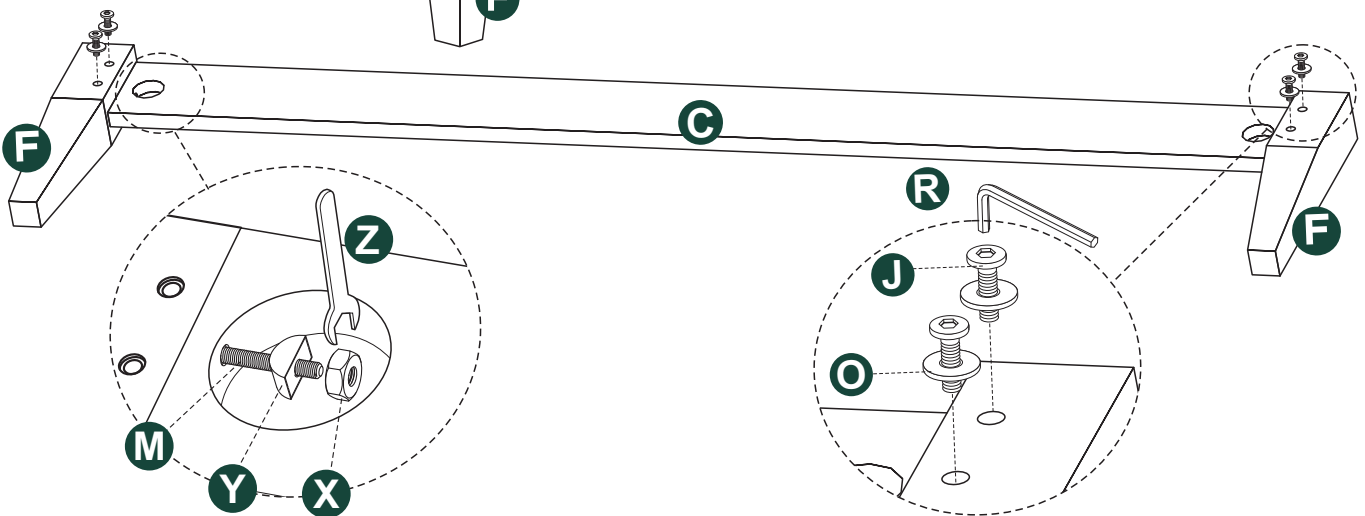

Then insert both foot legs to ends of panel (C). Attach washer (Y) and nut (X) to the bolt (M) to connect foot legs to panel (C). Tighten with wrench (Z).

Finally, attach washer (O) to bolt (J). Thread (J) bolts into the holes in the leg (F). Do not tighten. These will be tightened in later steps.

7

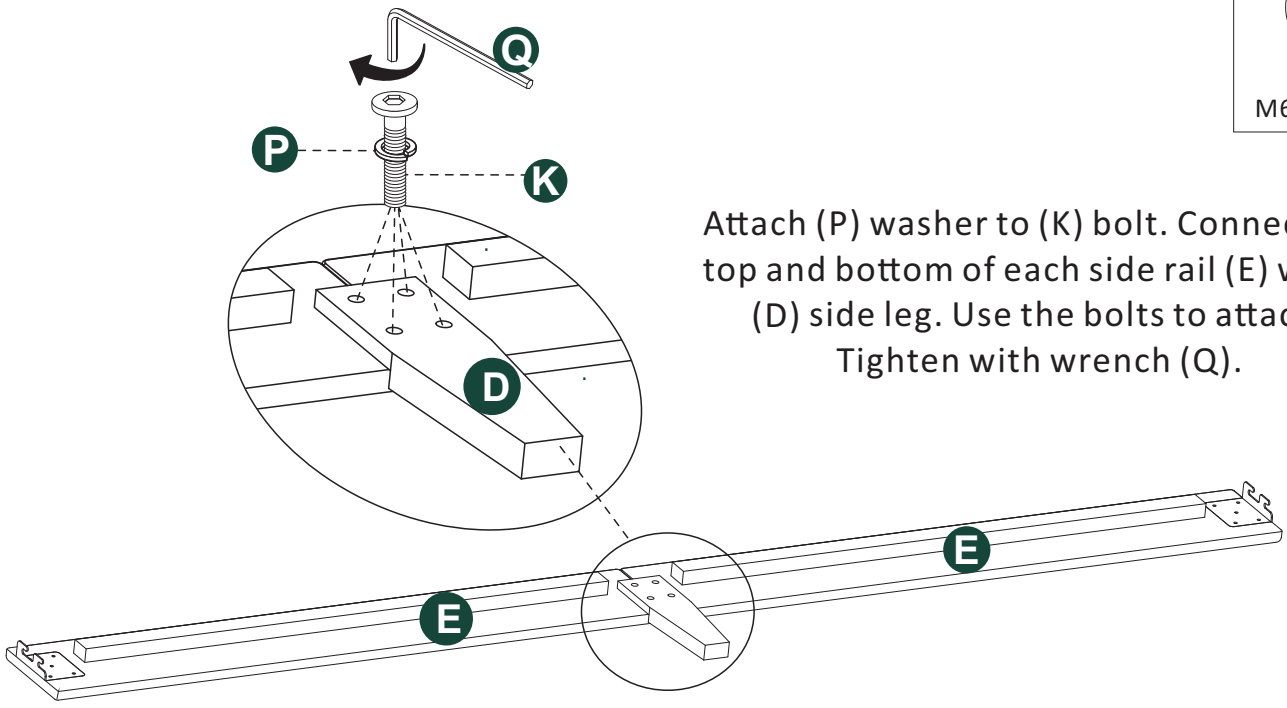
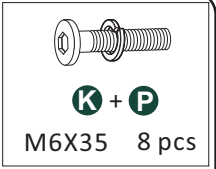

Attach (P) washer to (K) bolt. Connect the top and bottom of each side rail (E) with a (D) side leg. Use the bolts to attach. Tighten with wrench (Q).

Repeat steps to assemble right side rail.

8

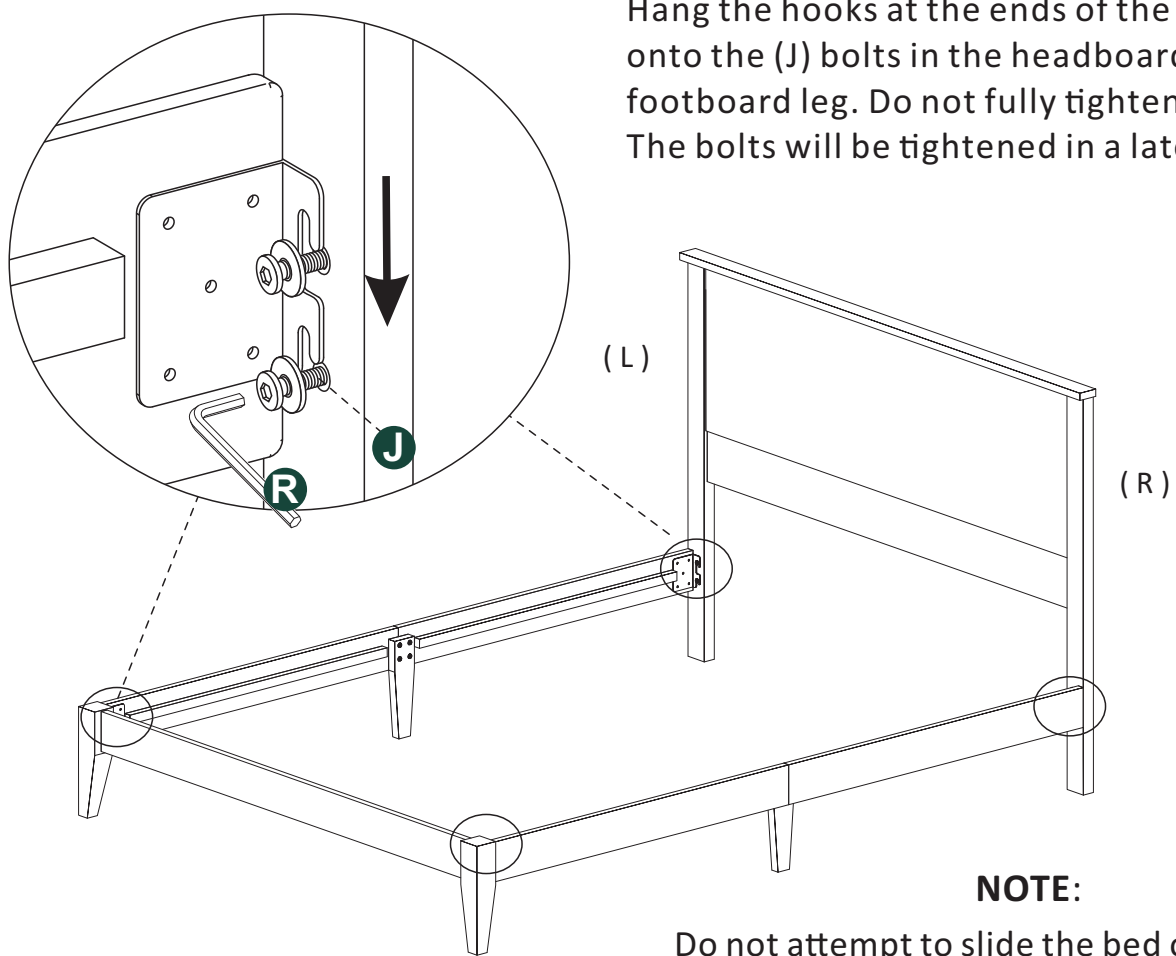

Hang the hooks at the ends of the side rails onto the (J) bolts in the headboard leg and the footboard leg. Do not fully tighten the (J) bolts. The bolts will be tightened in a later step.

NOTE:

Do not attempt to slide the bed once it is fully assembled. Sliding the bed could result in damage to the rails, headboard, or footboard. Assembled bed should be lifted and carried when being moved (not slid).

9

Assemble the slat system by attaching the slats to the (I) supports and (H) legs. First, extend the slats. Then, line up the holes in the slats with the holes in the (I) supports and the holes in the tops of the (H) legs. Use an (L) bolt through the holes to attach them together.

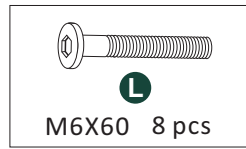

Tighten with wrench (Q).

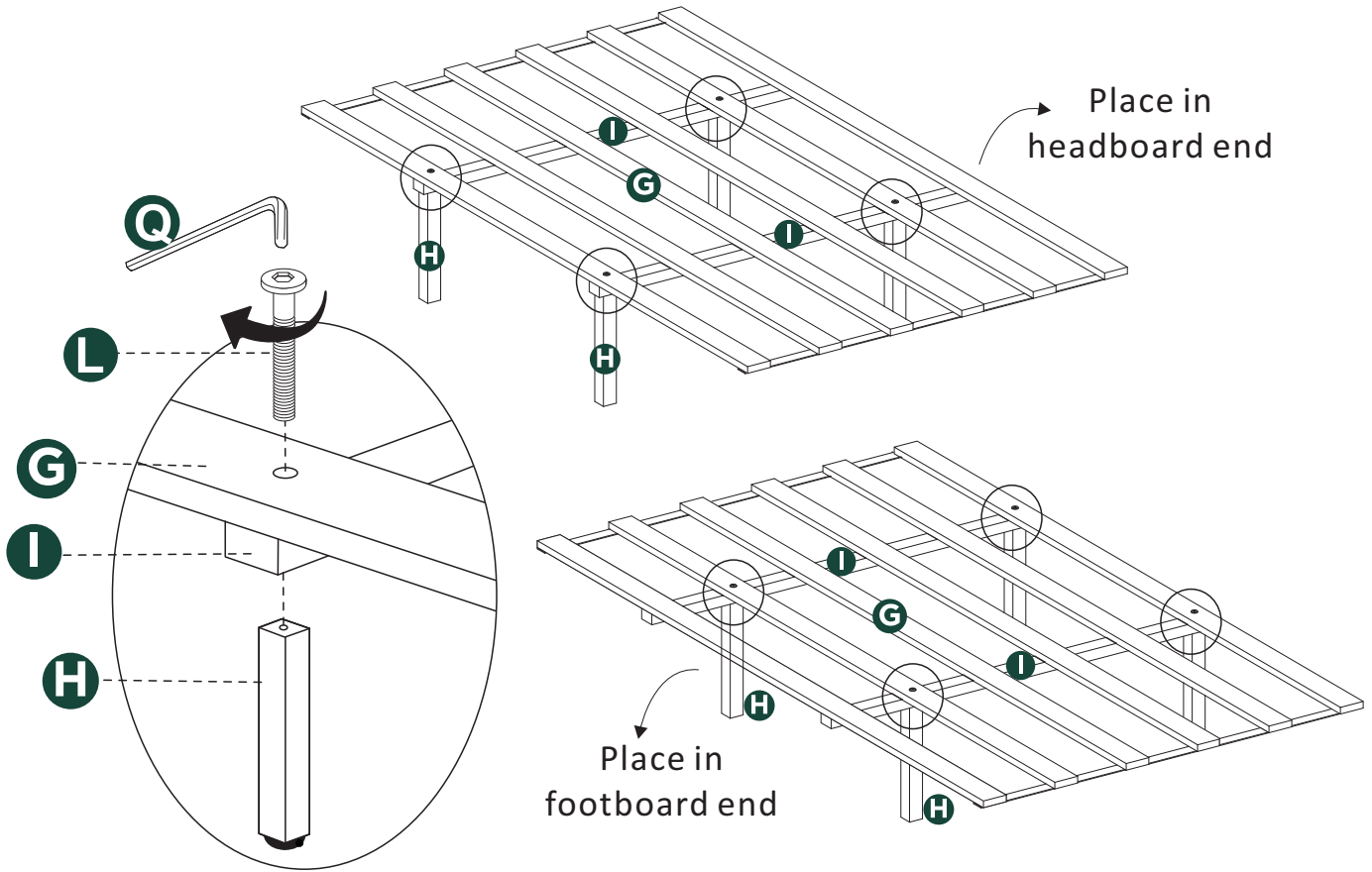

After the slat system is assembled, place the slats into the frame of the bed as shown, and velcro the slats to the cleat of side rail as shown below.

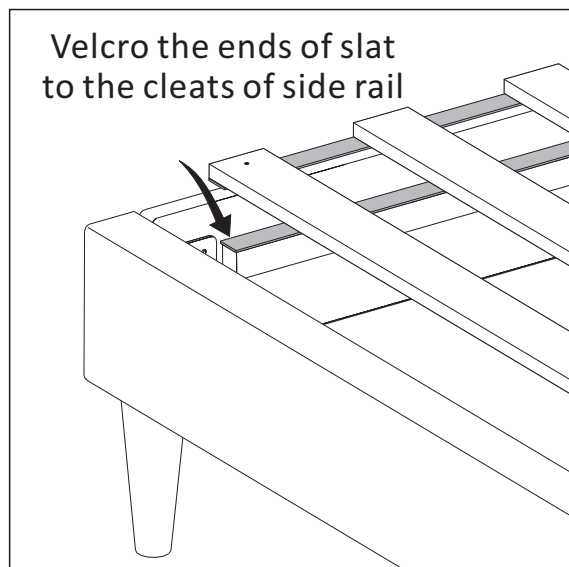

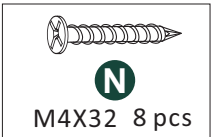

NOTE:

The center support leg glide sits approximately 1/4" off of the floor. The glide will usually touch the floor after a mattress is placed on the bedframe.

Do not place a mattress on bedframe until it is fully assembled and tightened. The bedframe should be located in your desired location. Sliding the bed with weight upon it can compromise the integrity of the center support legs.

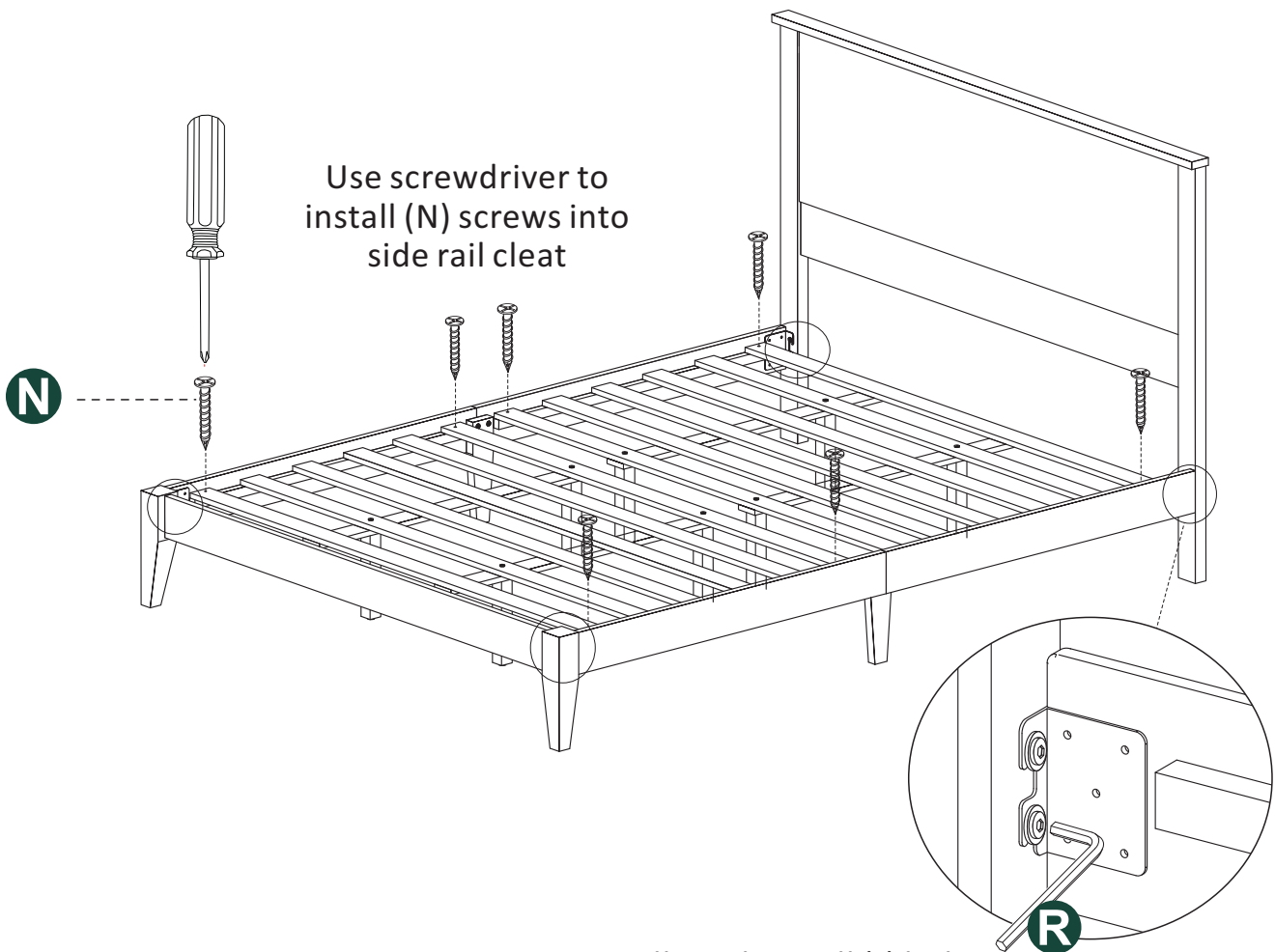
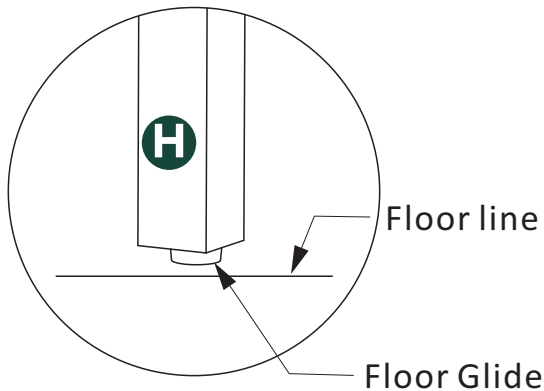

Finally, tighten all (J) bolts, tighten with wrench (R).

You're all finished! Sweet dreams!