

# Assembly Instructions

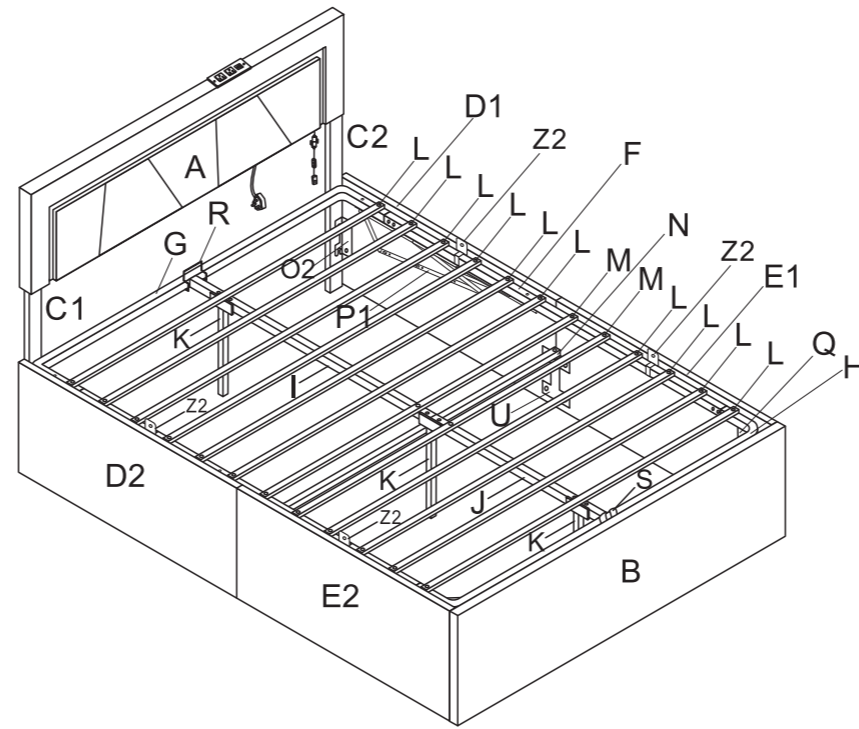
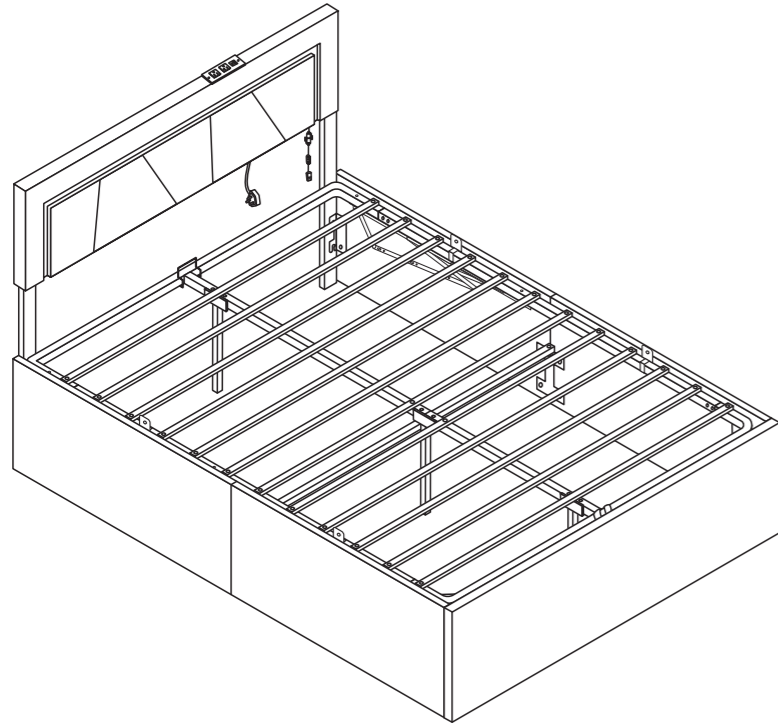

**Dear Customers,**  
Thank you for purchasing our product. Please read this instruction manual carefully after receiving this product. It will help you assemble this product quickly, safely and correctly. You can keep this manual for future reference.

Notice: Do not tighten the screws too tightly at the beginning of the assembly. After each hole position is matched well, with gently force to screw, if there is no problem, then tighten all the screws.

<b>A</b>  1PC	<b>B</b>  1PC	<b>C1</b>  1PC	<b>C2</b>  1PC
<b>D1</b>  1PC	<b>D2</b>  1PC	<b>E1</b>  1PC	
<b>E2</b>  1PC	<b>F</b>  2PCS	<b>G</b>  1PC	
<b>H</b>  1PC	<b>I</b>  1PC	<b>J</b>  1PC	
<b>K</b>  3PCS	<b>L</b>  10PCS	<b>M</b>  2PCS	

1

<b>N</b>  1PC	<b>O1</b>  1PC	<b>O2</b>  1PC	<b>O3</b>  1PC	<b>O4</b>  1PC
<b>P1</b>  1PC	<b>P2</b>  1PC	<b>Q</b>  2PCS		
<b>R</b>  1PC	<b>S</b>  1PC	<b>T</b>  2PCS		
<b>U</b>  2PCS	<b>V</b>  4PCS M8x55mm	<b>W</b>  60PCS M8x20mm		
<b>X</b>  6PCS M6x35mm	<b>Y</b>  26PCS M6x25mm	<b>Z</b>  1PC		
<b>Z1</b>  1PC	<b>Z2</b>  4PCS	<b>Z3</b>  1PC		

2

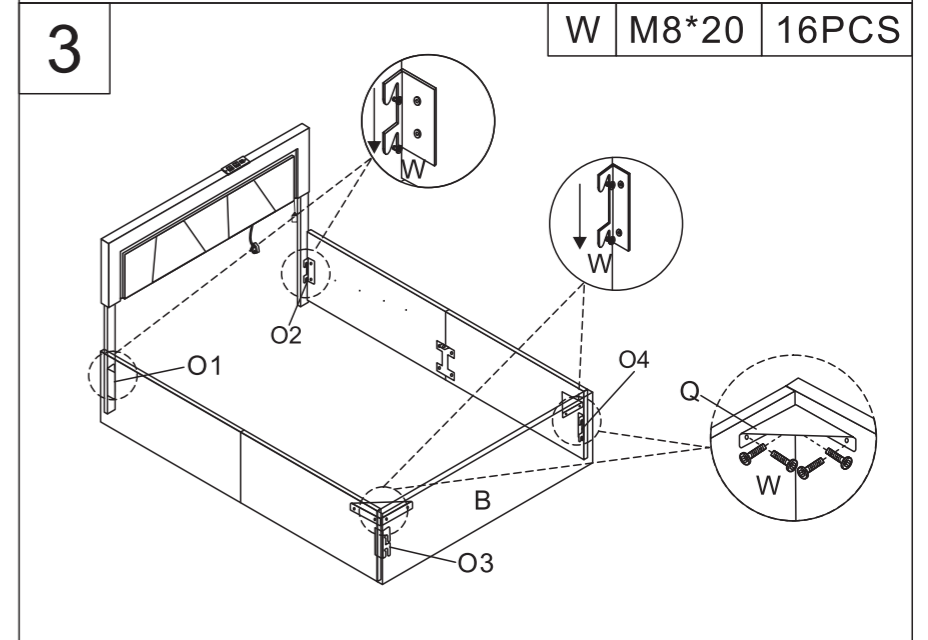
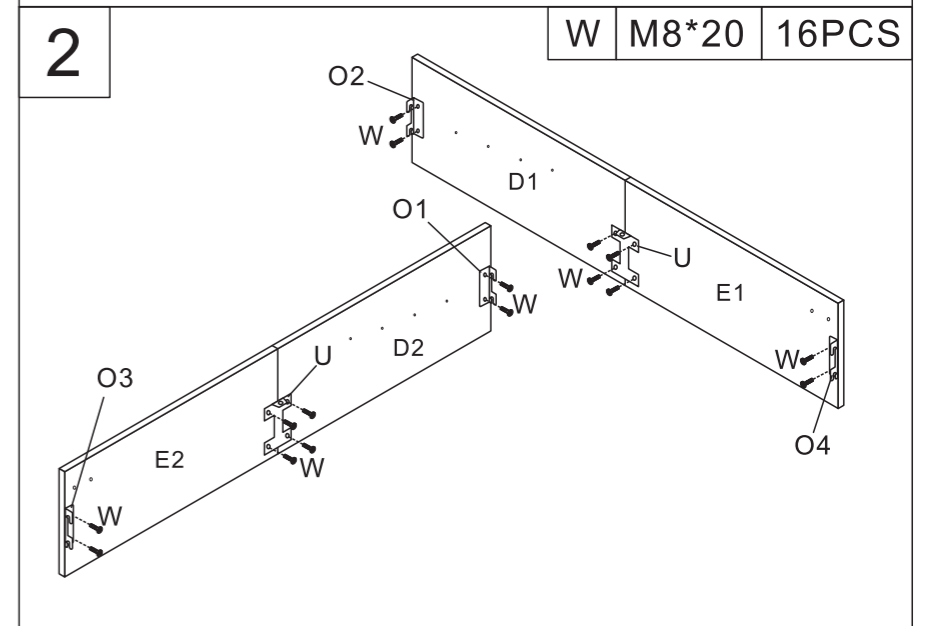
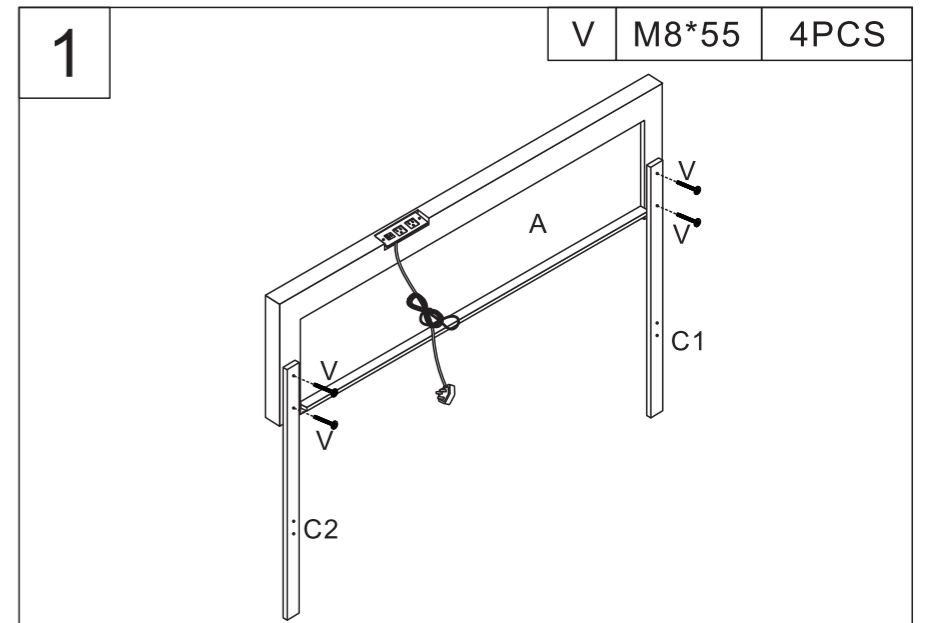

3

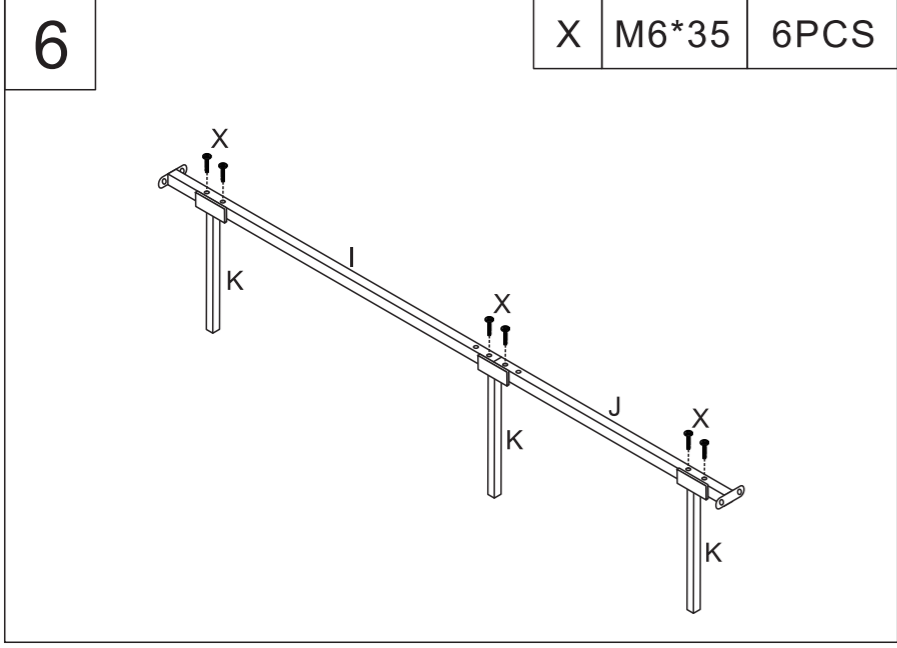
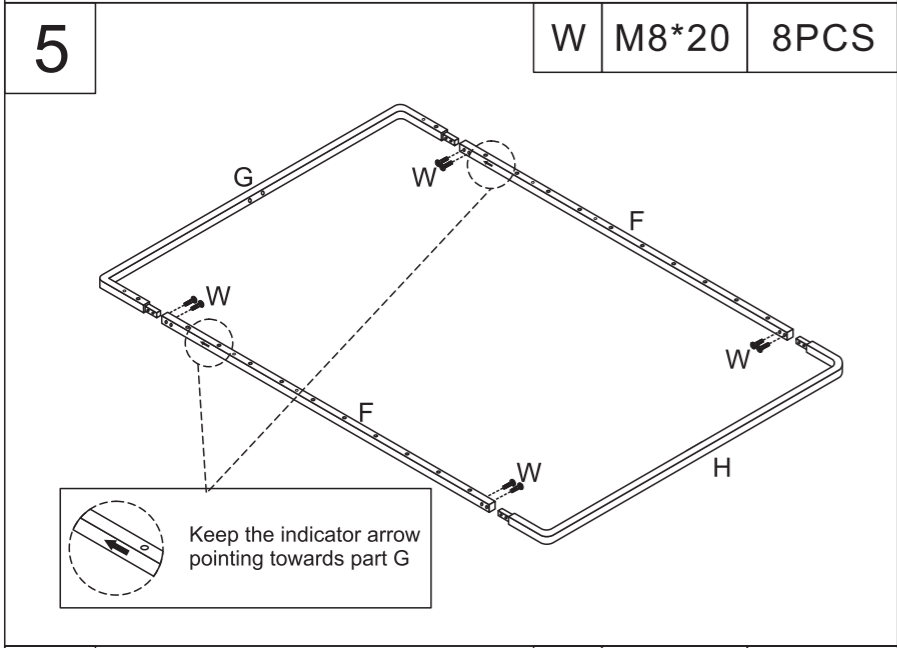
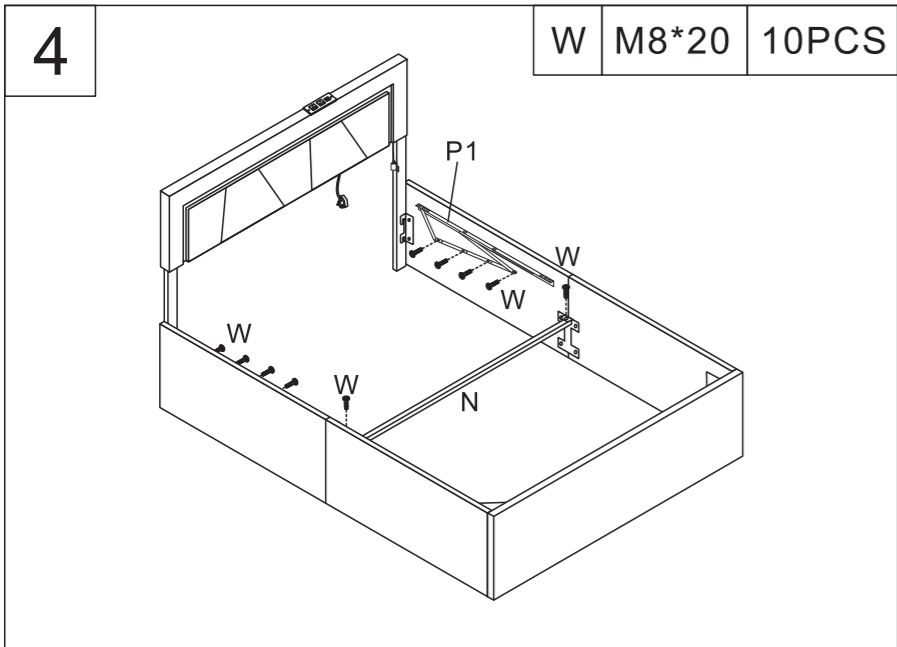

4

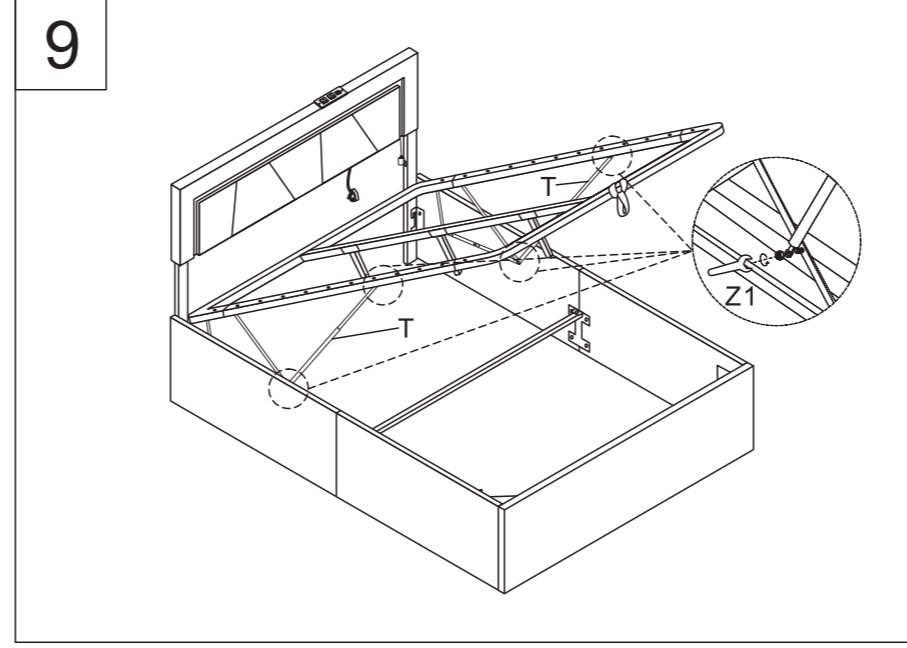
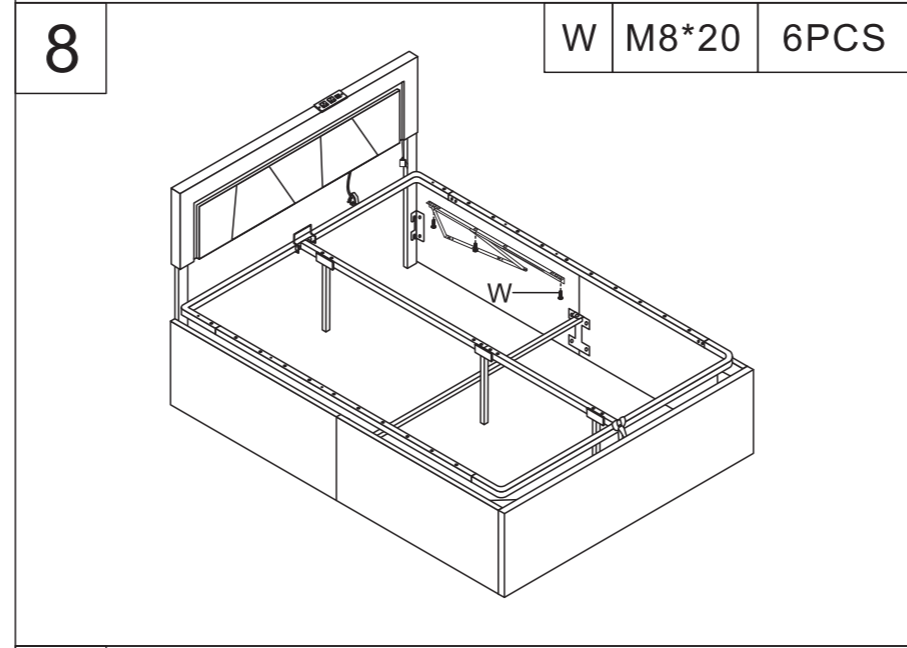
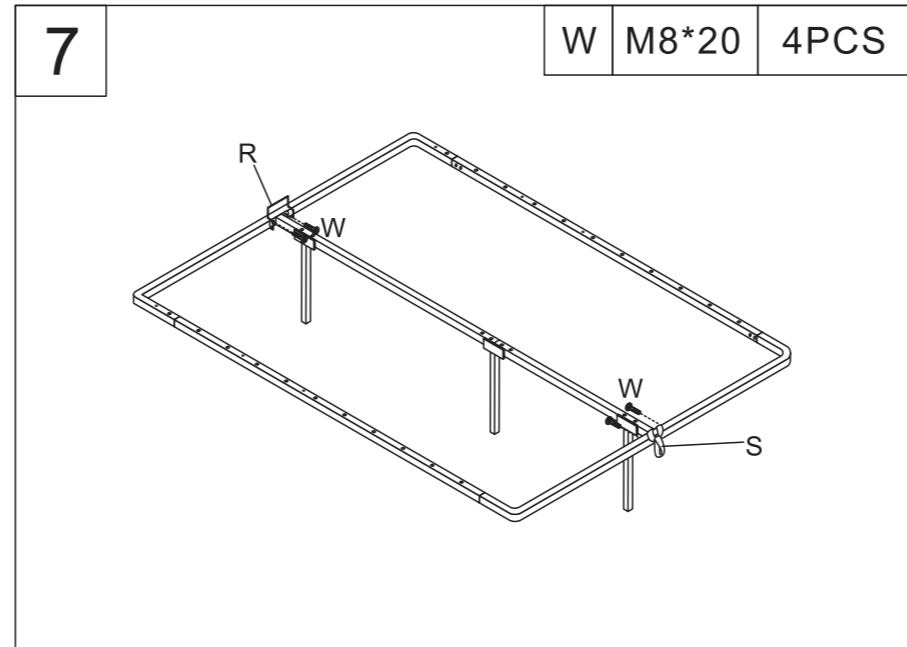

5

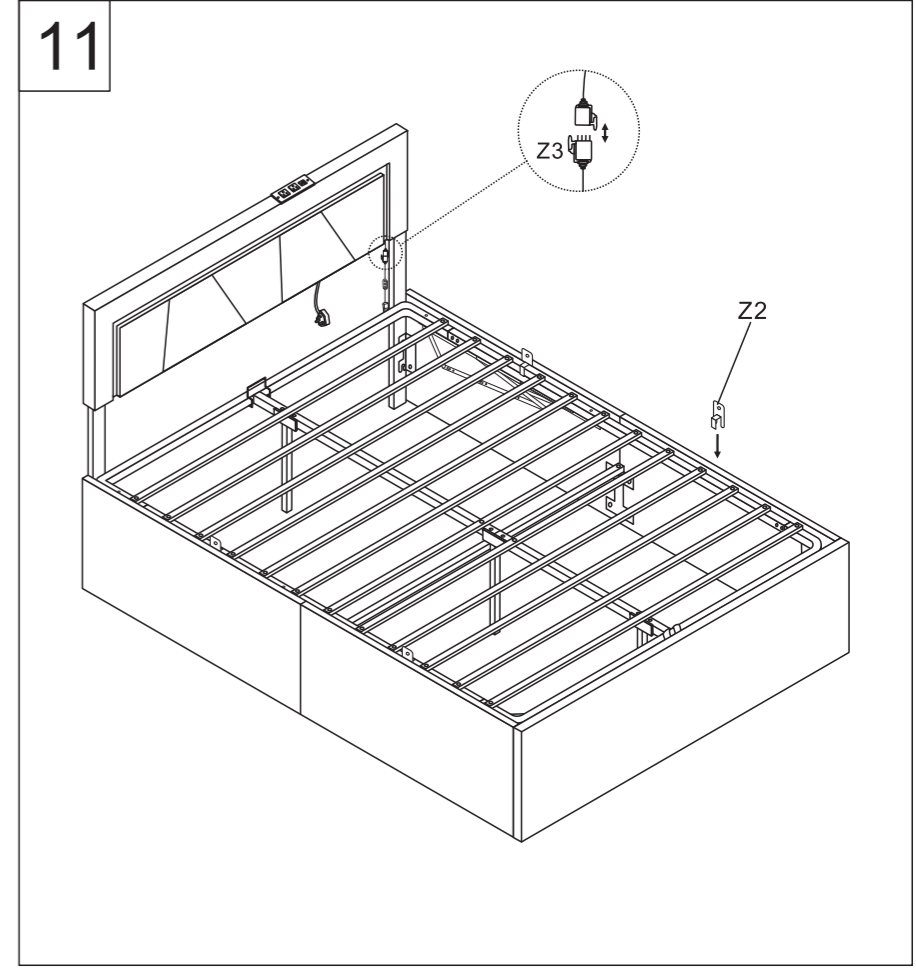
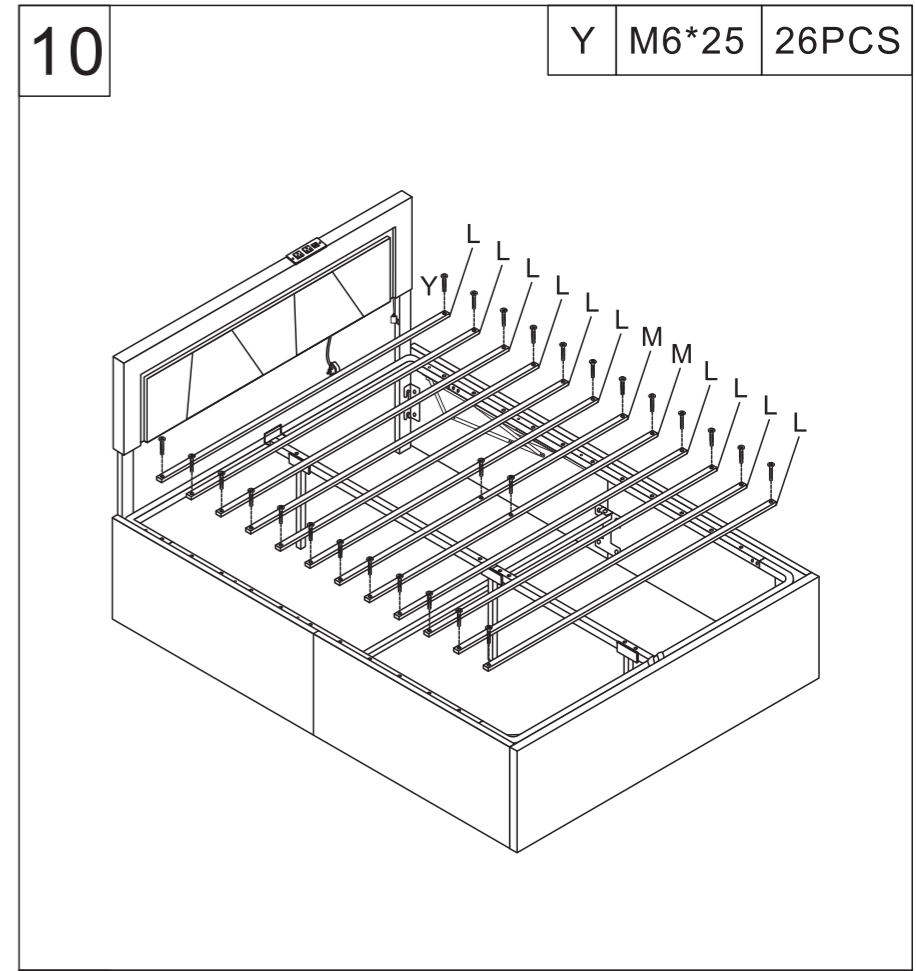

6