

ASSEMBLY INSTRUCTIONS



Fine Furniture for every stage of life

SERVING CART

ASSEMBLY INSTRUCTIONS

ASSEMBLY TIPS:

1. Remove hardware from box and sort by size.
2. Please check to see that all hardware and parts are present prior to start of assembly.
3. Please follow attached instructions in the same sequence as numbered to assure fast & easy assembly.



WARNING!

1. Don't attempt to repair or modify parts that are broken or defective. Please contact the store immediately.
2. This product is for home use only and not intended for commercial establishments.

ASSEMBLY TIME 65 MINUTES

PARTS IDENTIFICATION

A TOP TRAY

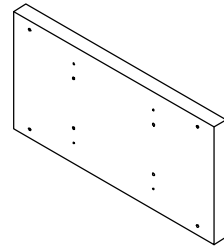

1PC

B BOTTOM TRAY

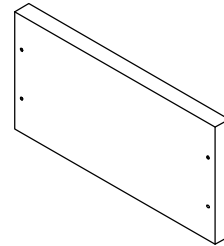

1PC

C LEFT PANEL

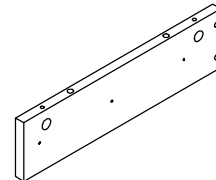

1PC

D RIGHT PANEL

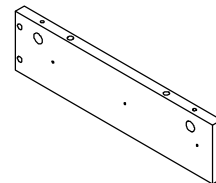

1PC

E BACK PANEL

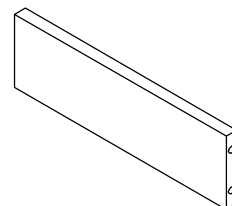

1PC

ASSEMBLY INSTRUCTIONS

PARTS IDENTIFICATION

F DRAWER FRONT PANEL

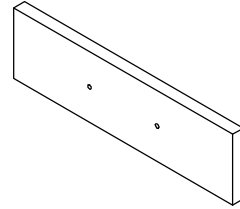

1PC

G DRAWER LEFT PANEL

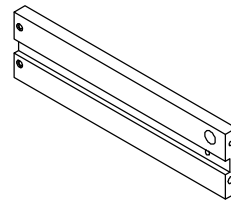

1PC

H DRAWER RIGHT PANEL

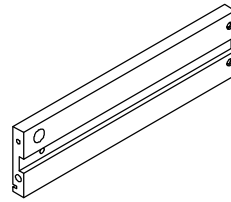

1PC

I DRAWER BACK PANEL

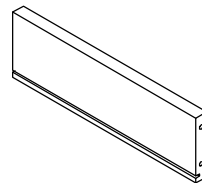

1PC

J DRAWER BOTTOM PANEL

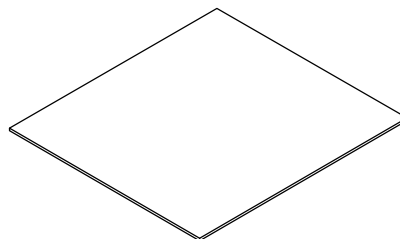

1PC

K LEG 1

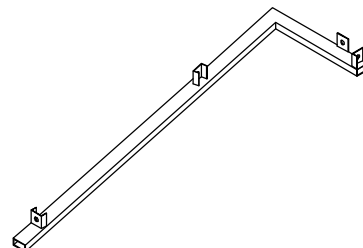

2PCS

ASSEMBLY INSTRUCTIONS

PARTS IDENTIFICATION

L

LEG 2

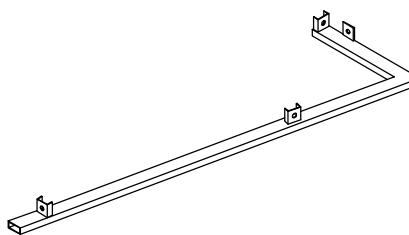

2PCS

M

TOP CROSSBAR

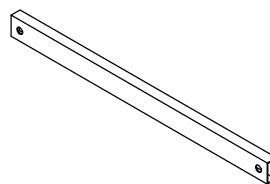

1PC

N

MIDDLE CROSSBAR

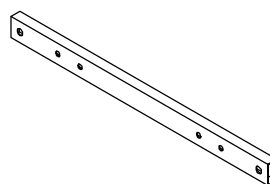

2PCS

O

BOTTOM CROSSBAR

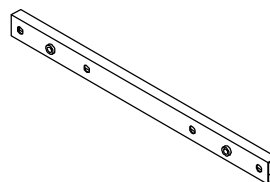

2PCS

P

HANDLE

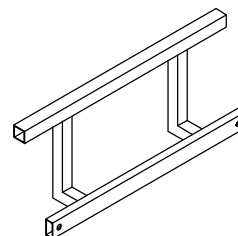

1PC

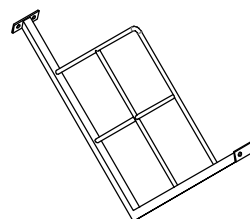

Q

HOLDER





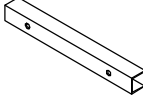
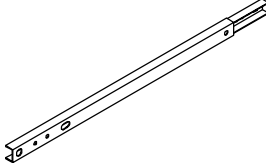





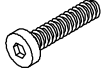



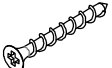

2PCS

ASSEMBLY INSTRUCTIONS

R	DRAWER HANDLE		1PC
S	SLIDE RAIL		2PCS
T	WHEEL		4PCS

HARDWARE IDENTIFICATION

1	CAM BOLT (38mm)		6PCS	9	LONG BOLT (1/4" x 21mm SR)		4PCS
2	CAM LOCK (ϕ 15mm)		6PCS	10	CAP (13 x 26mm SR)		8PCS
3	WOOD DOWEL (8 x 30mm)		10PCS	11	DRAWER HANDLE CAP (16 x 16mm SR)		2PCS
4	WOOD SCREW (8 x 38mm)		4PCS	12	HANDLE CAP (20 x 20mm SR)		2PCS
5	HANDLE BOLT (5/32" x 22mm)		2PCS	13	GLUE		1PC
6	SMALL BOLT (5/32" x 12mm)		2PCS	14	HOLDER BOLT (3/16" x 12mm SR)		8PCS
7	SCREW (3 x 8mm)		6PCS	15	ALLEN WRENCH (4mm)		1PC
8	SHORT BOLT (1/4" x 12mm SR)		16PCS	16	HEXAGONAL KEY (8mm)		1PC

ASSEMBLY INSTRUCTIONS

STEP 1 Do not tighten until each step is completed or instructed.

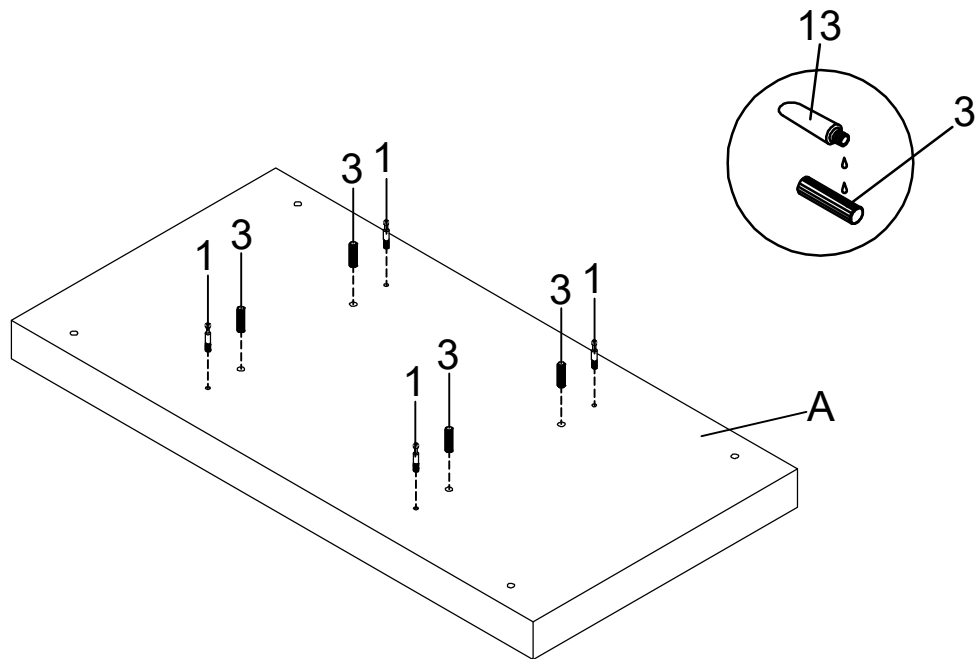

STEP 2

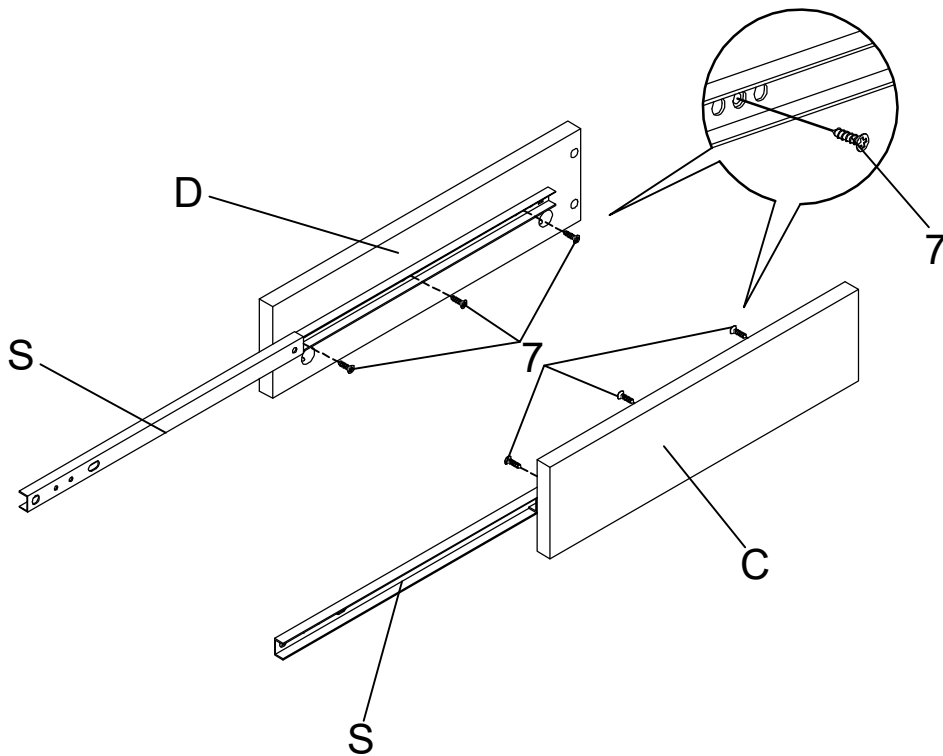

ASSEMBLY INSTRUCTIONS

STEP 3

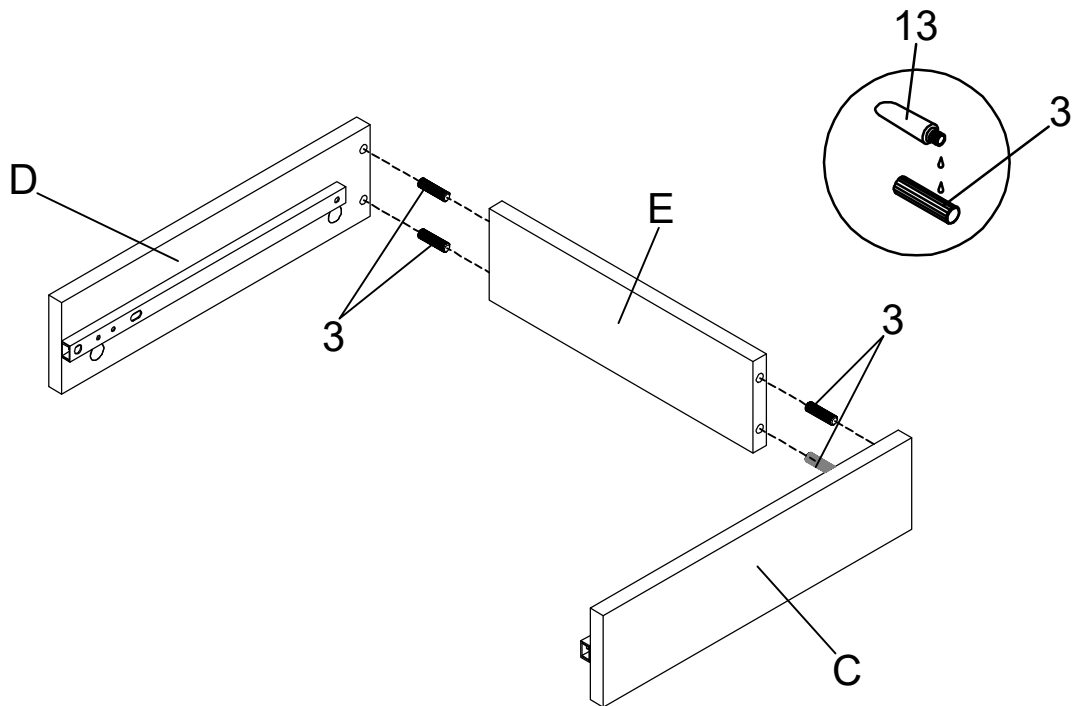

STEP 4

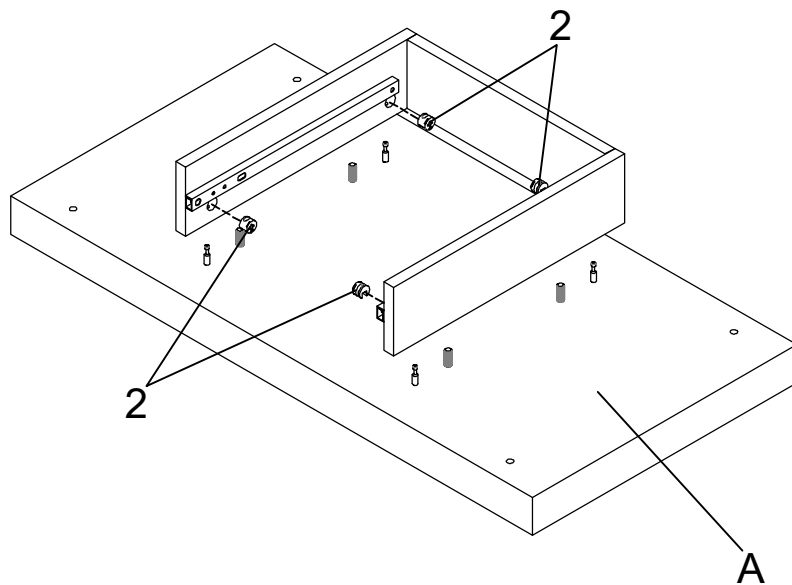

ASSEMBLY INSTRUCTIONS

STEP 5

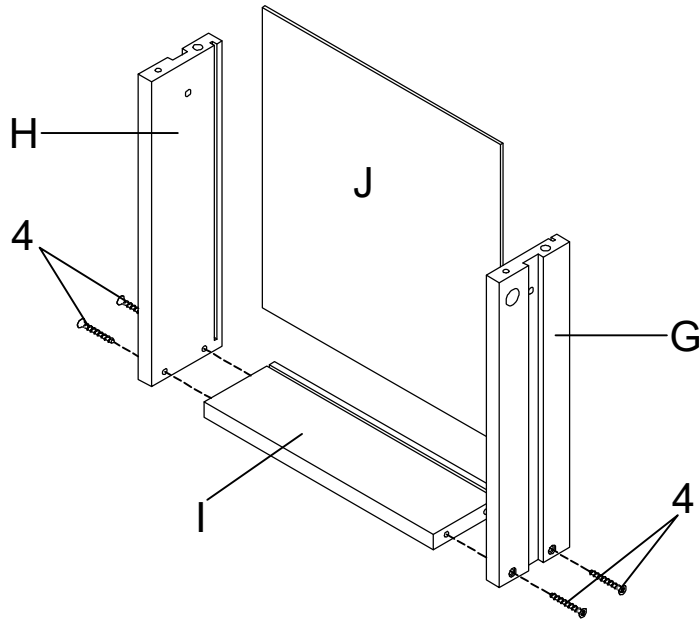

STEP 6

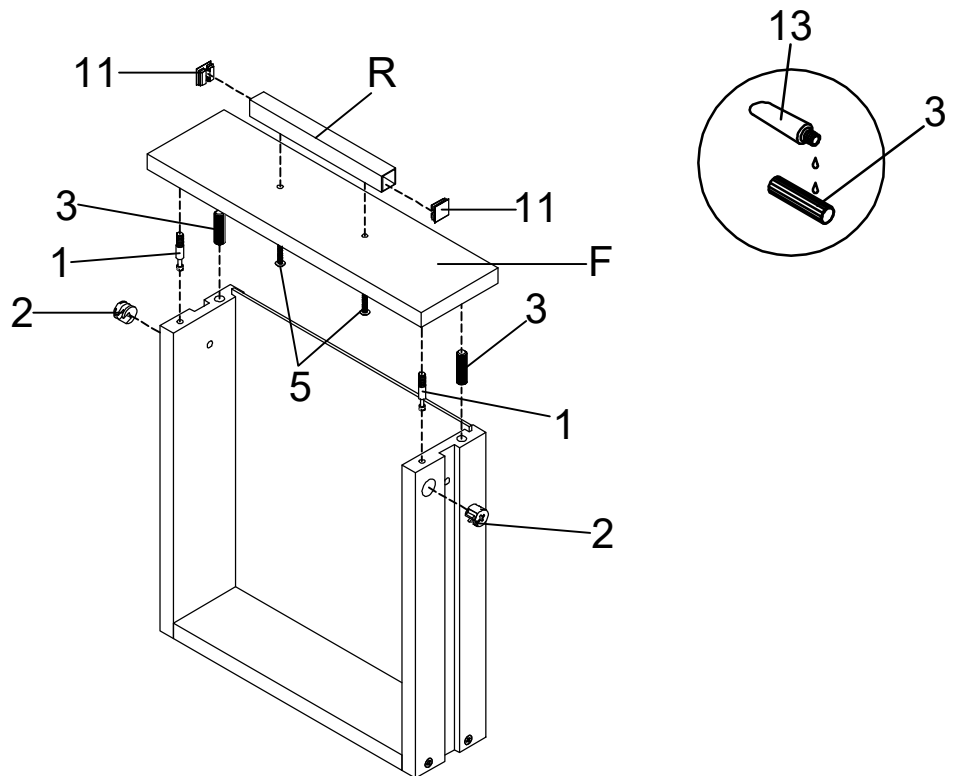

ASSEMBLY INSTRUCTIONS

STEP 7

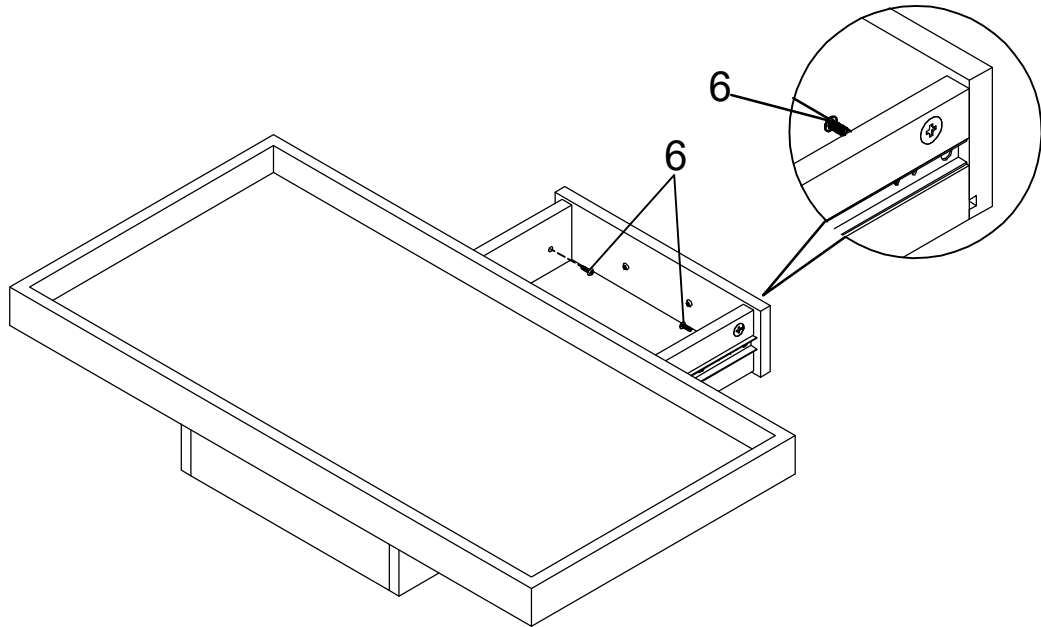

STEP 8

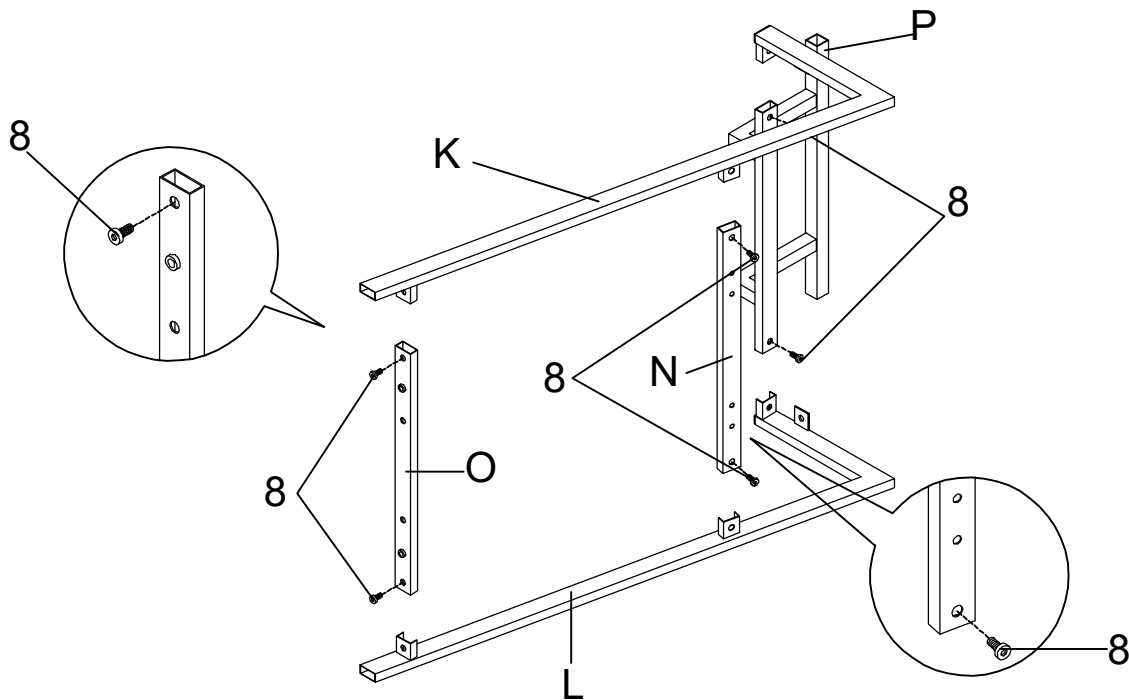

ASSEMBLY INSTRUCTIONS

STEP 9

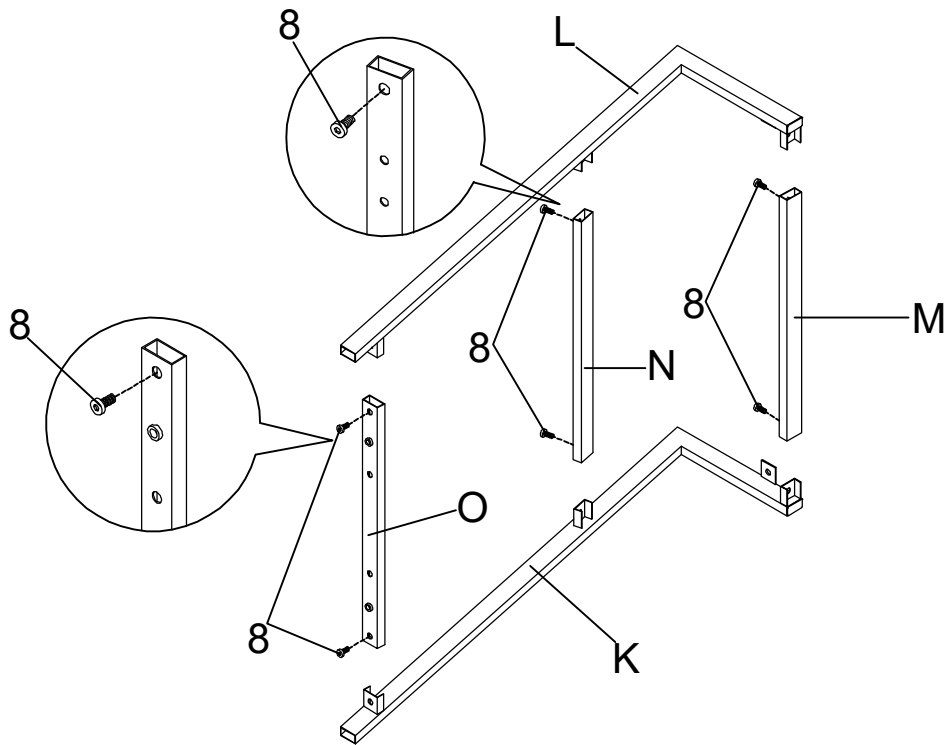

STEP 10

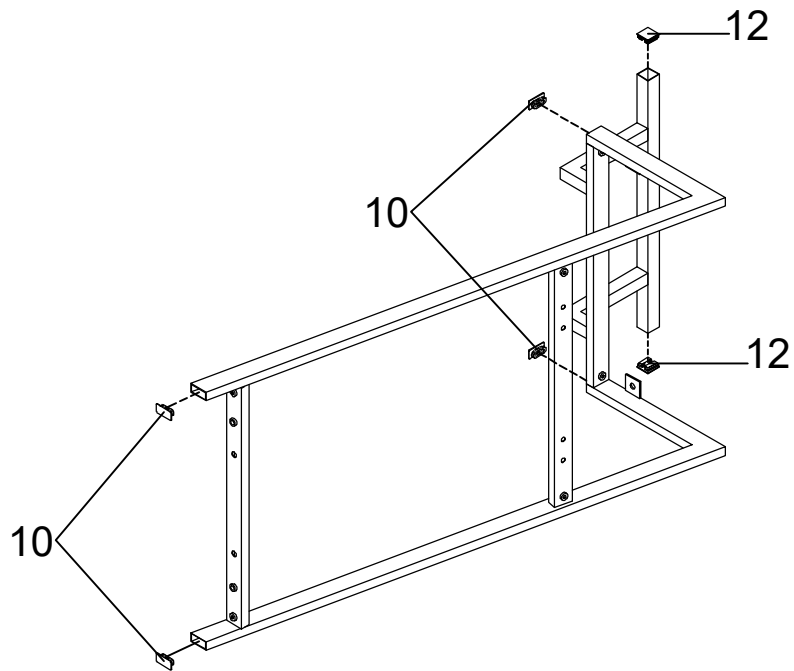

ASSEMBLY INSTRUCTIONS

STEP 11

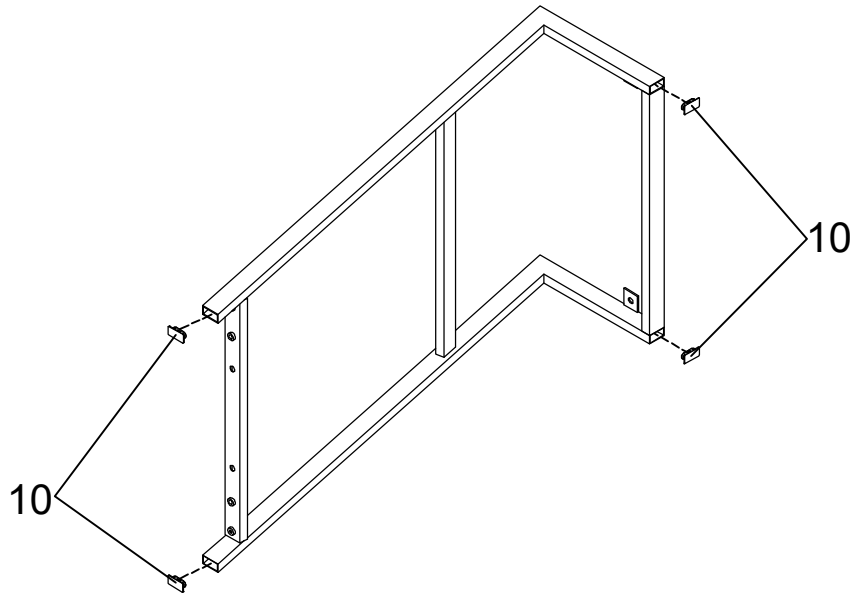

STEP 12

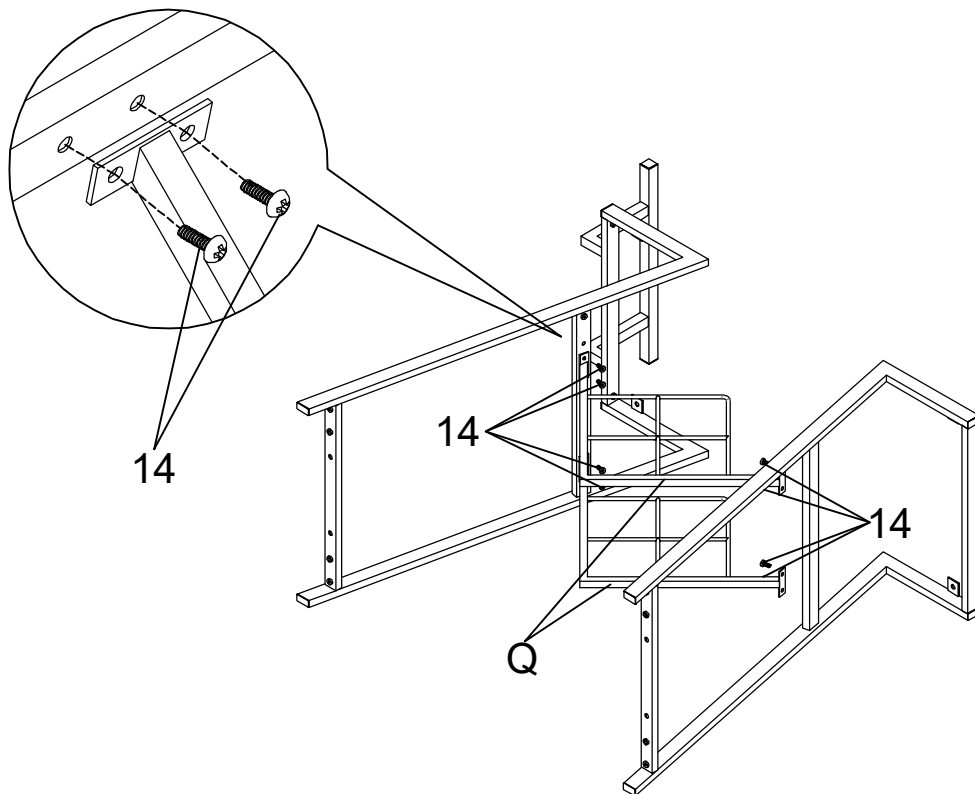

ASSEMBLY INSTRUCTIONS

STEP 13

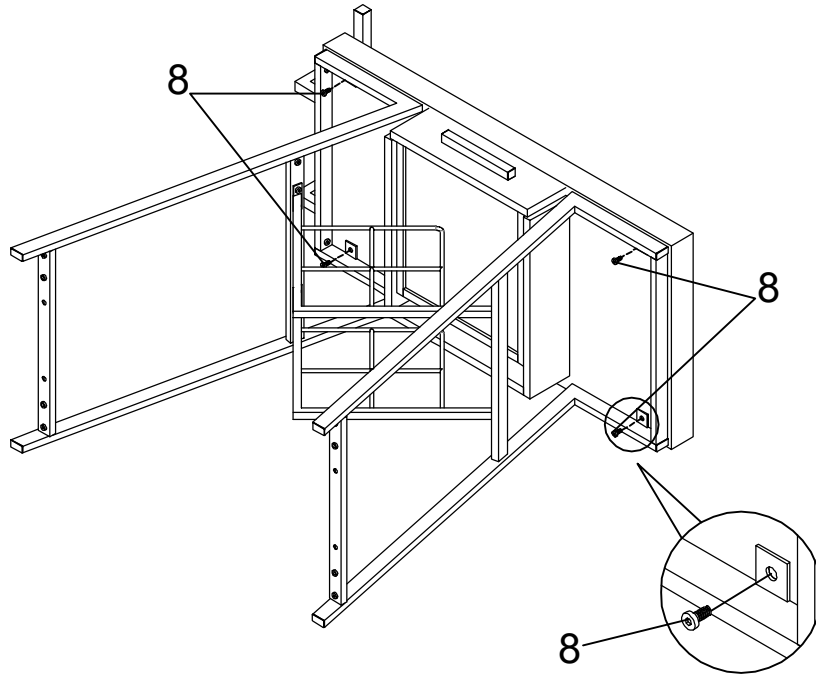

STEP 14

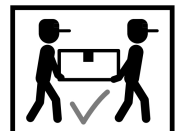
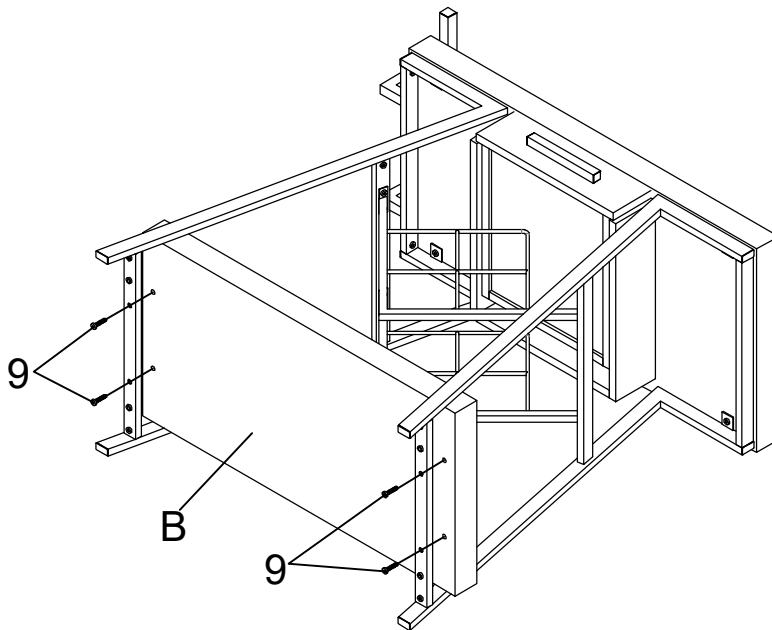

ASSEMBLY INSTRUCTIONS

STEP 15

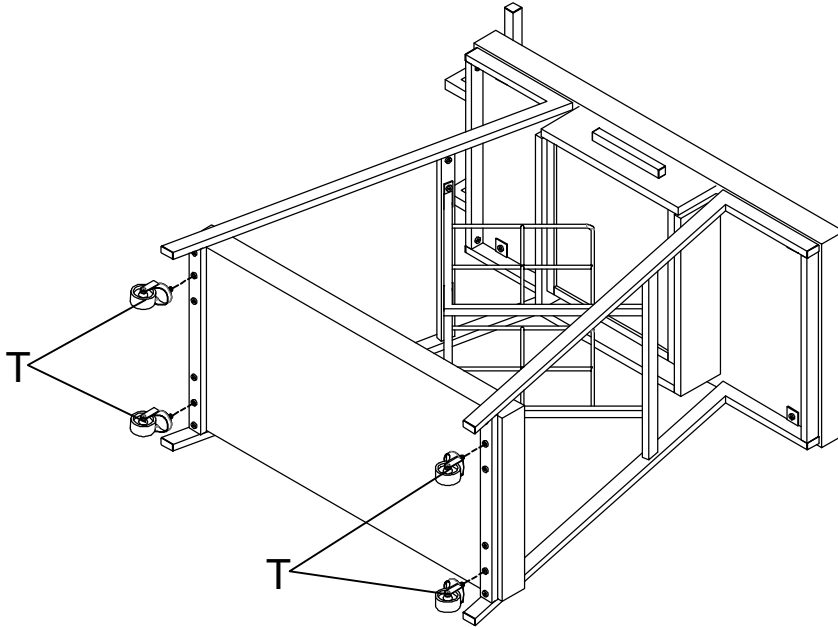

STEP 16

COMPLETE

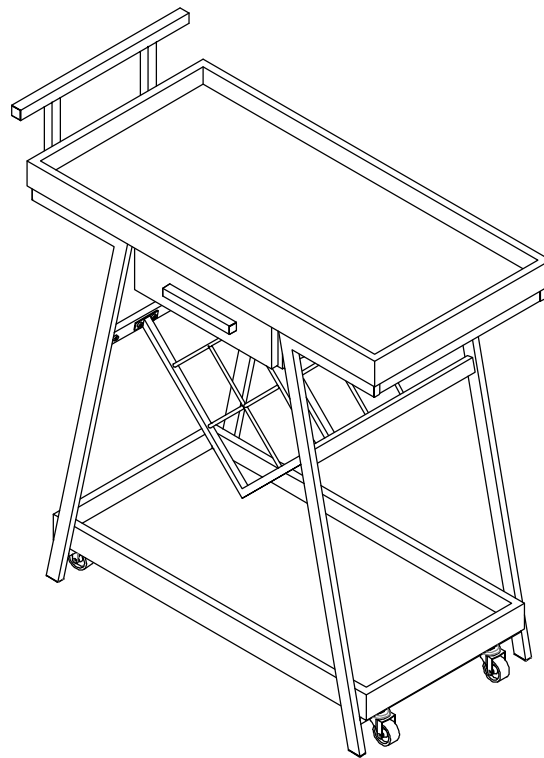

ASSEMBLY INSTRUCTIONS

Product Size : 826 X 400 X 889 H (MM)

Product Size : 32.5" X 15.75" X 35"

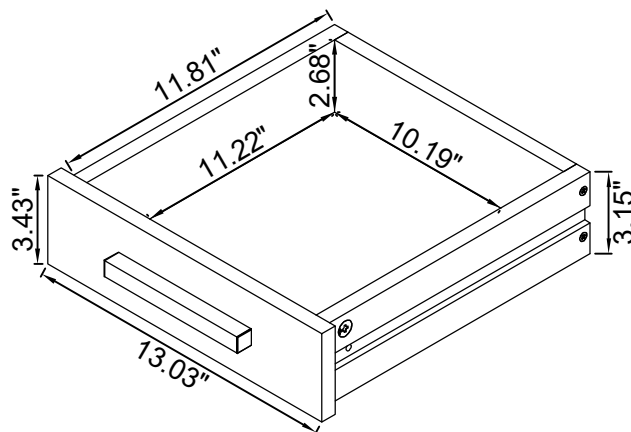
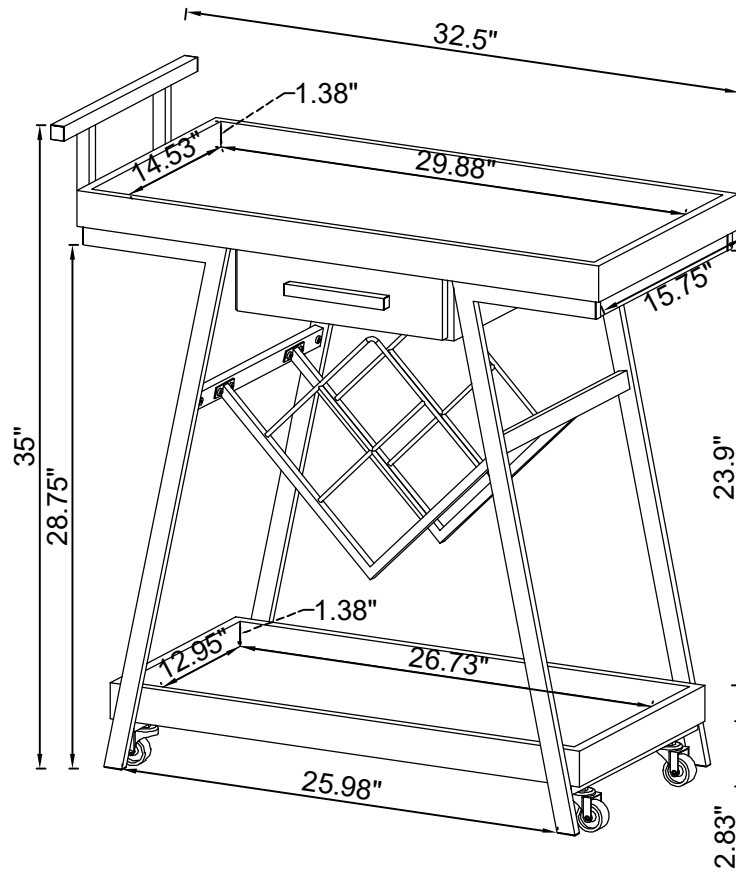

Note : Dimension tolerance $\pm 5\%$