

OFFICE TABLE

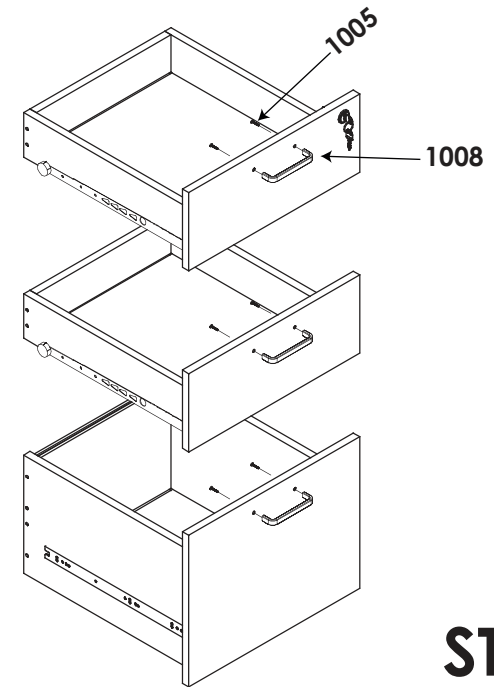

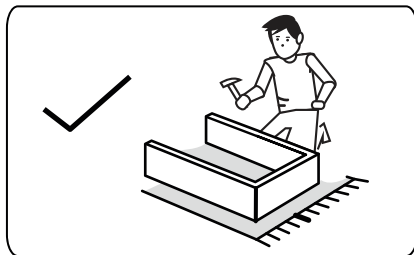

STEP:08

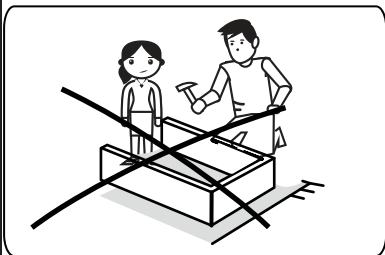
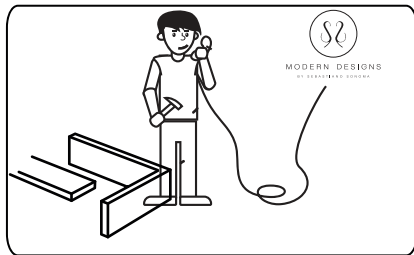
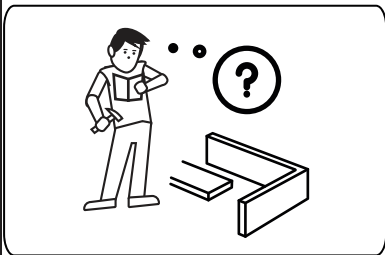
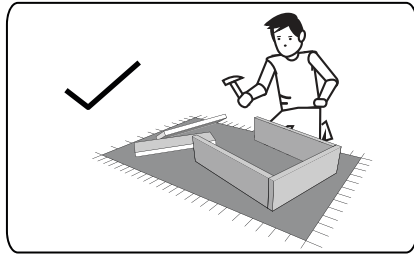
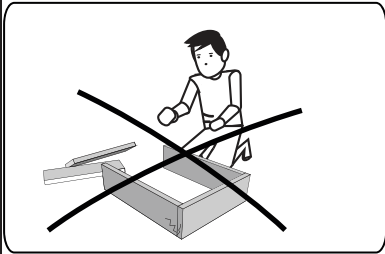
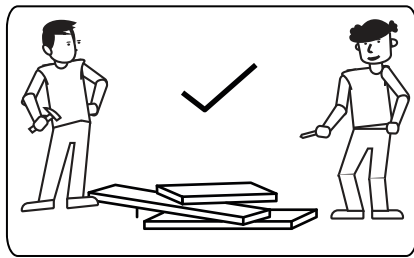
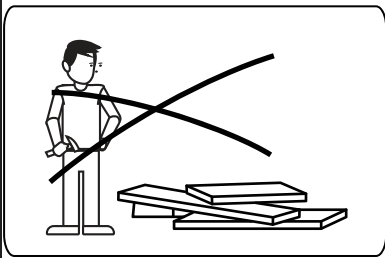
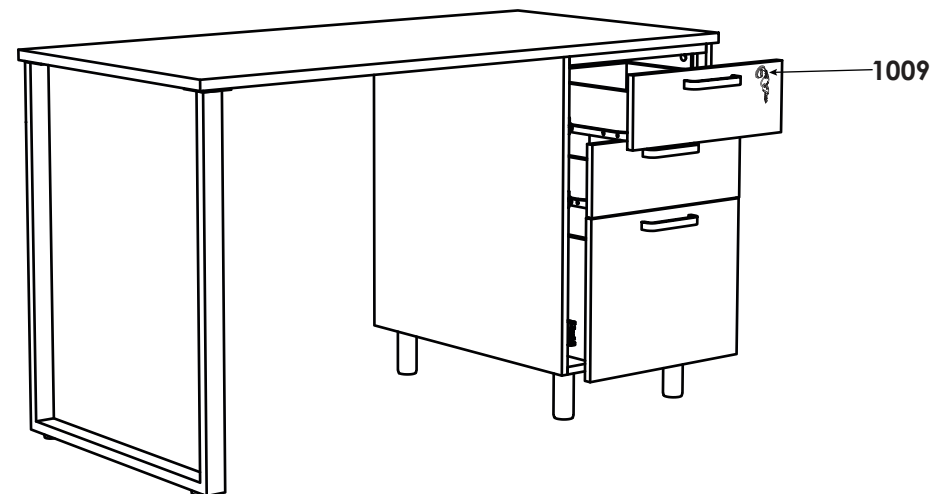

IMPORTANT NOTES

1. Place all wooden parts on a clean and smooth surface such as a rug or carpet to avoid the parts from being scratched.
2. Check to be sure that you have all parts and hardware.
3. Remove all wrapping materials, including stopples & packing straps before you start assemble.
4. Keep all hardware parts out of reach of children

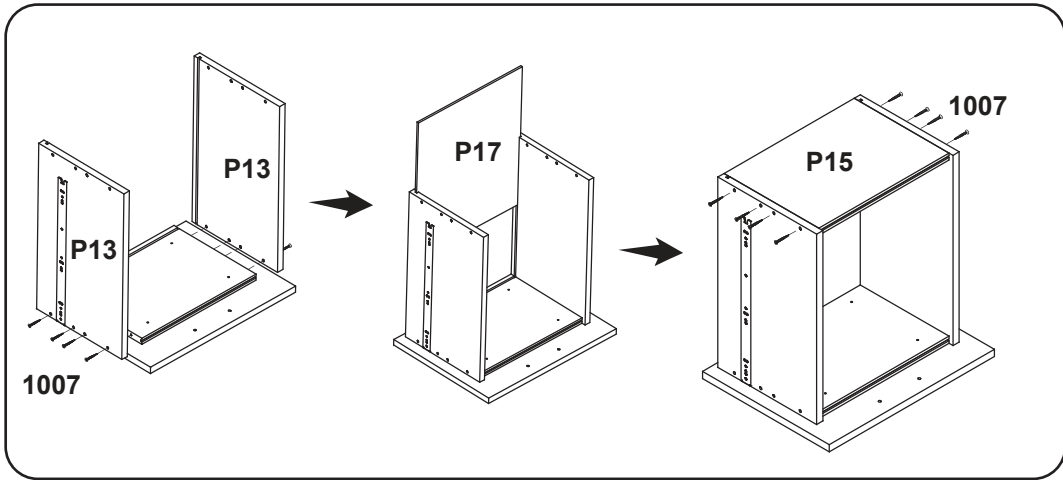
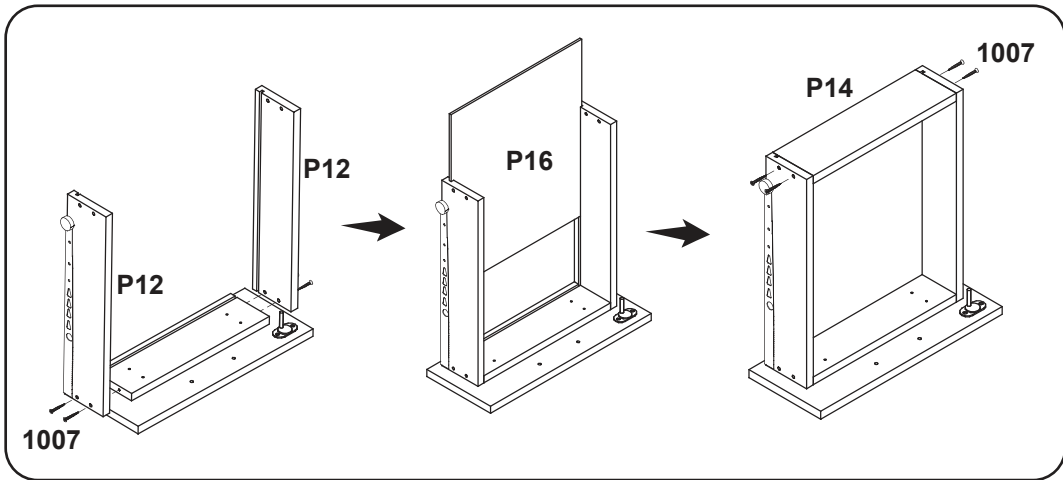

DRAWER ASSEMBLY STEP:07

HARDWARE & TOOL DETAILS

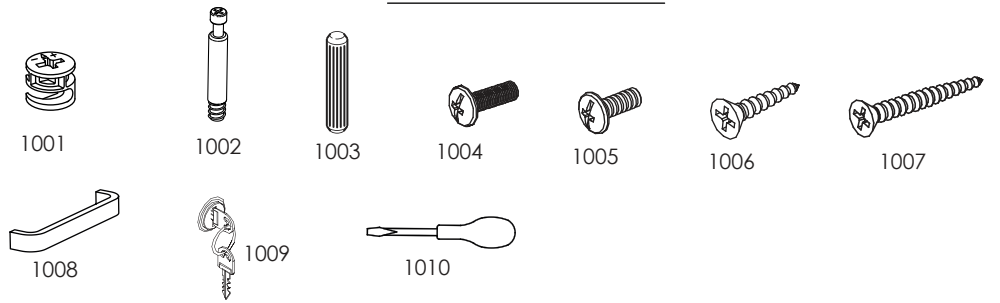

CODE	NAME	QTY	EXTRA
1001	CAM LOCK	17 pcs	1 pcs
1002	HOUSING PIN	17 pcs	1 pcs
1003	DOWEL	12 pcs	1 pcs
1004	BIG FLAT SCREW [M6 X 12]	06 pcs	0
1005	BIG FLAT SCREW [M4 X 20]	06 pcs	0
1006	SCREW [M3.5 X 14]	16 pcs	0
1007	SCREW [M4 X 35]	34 pcs	0
1008	HANDLE	03 pcs	0
1009	KEY	01 Unit [2pcs]	0
1010	STAR SCREW-DRIVER	NOT PROVIDED	

COMPONENT DETAILS

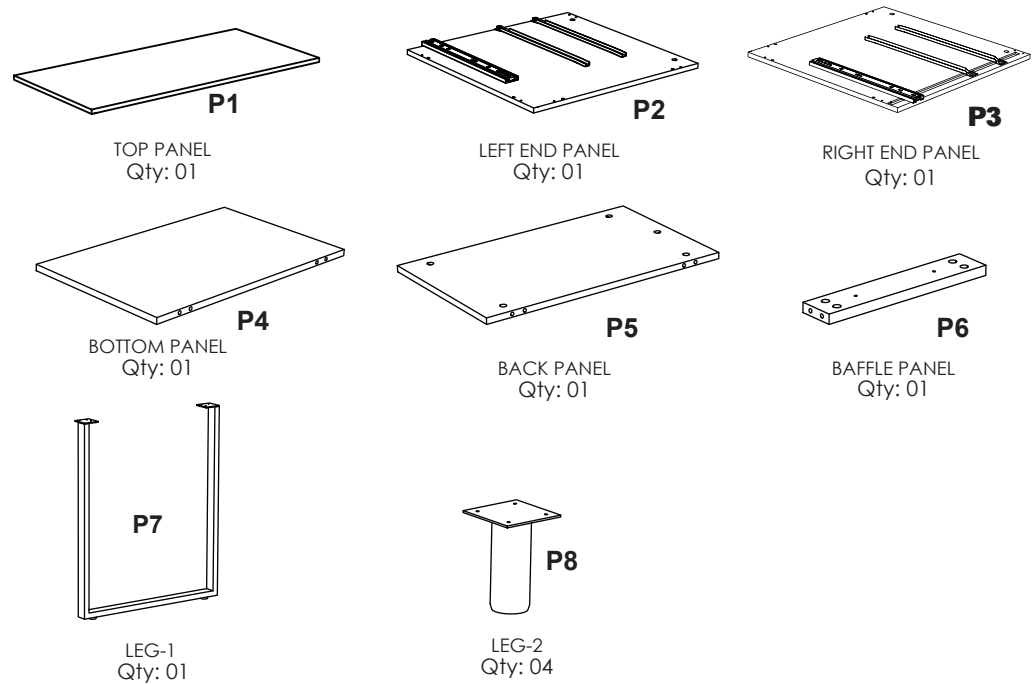

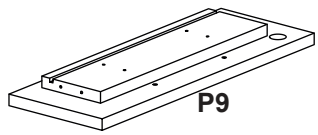

DRAWER FRONT PANEL-1
Qty: 01

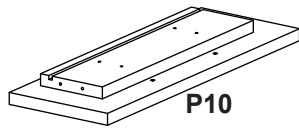

DRAWER FRONT PANEL-2
Qty: 01

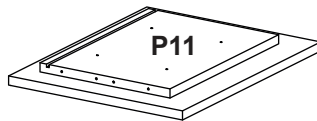

DRAWER FRONT PANEL-3
Qty: 01

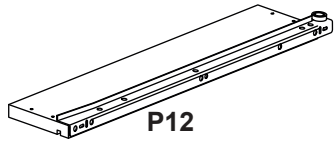

DRAWER LEFT SIDE PANEL-1
Qty: 04

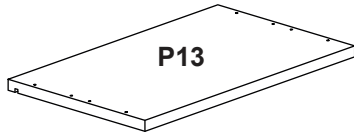

DRAWER SIDE PANEL-2
Qty: 02

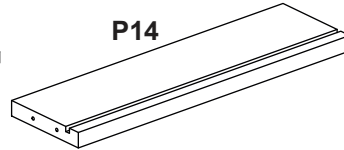

DRAWER BACK PANEL-1
Qty: 02

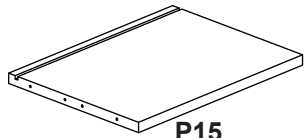

DRAWER BACK PANEL-2
Qty: 01

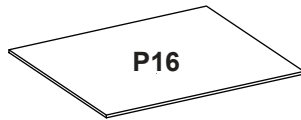

DRAWER BOTTOM PANEL-1
Qty: 02

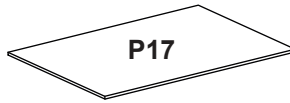

DRAWER BOTTOM PANEL-2
Qty: 01

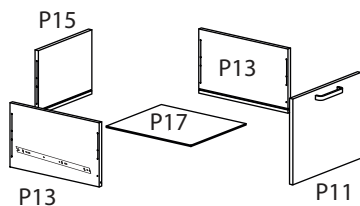
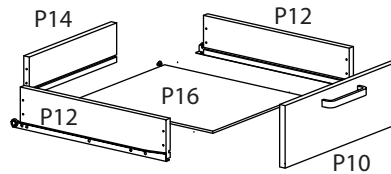
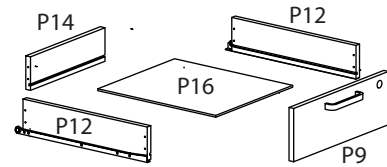
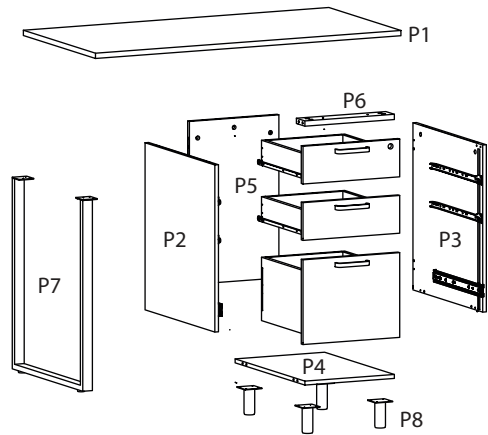
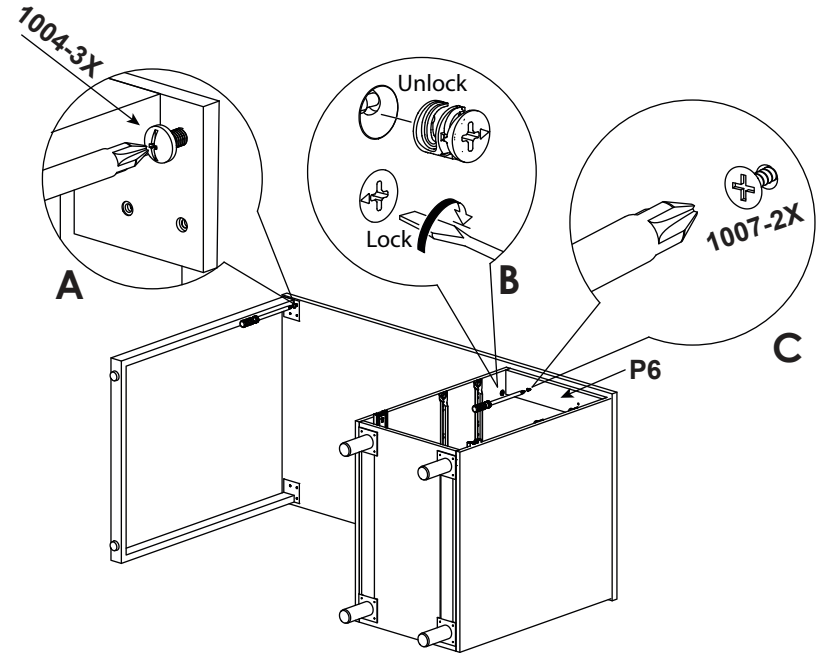
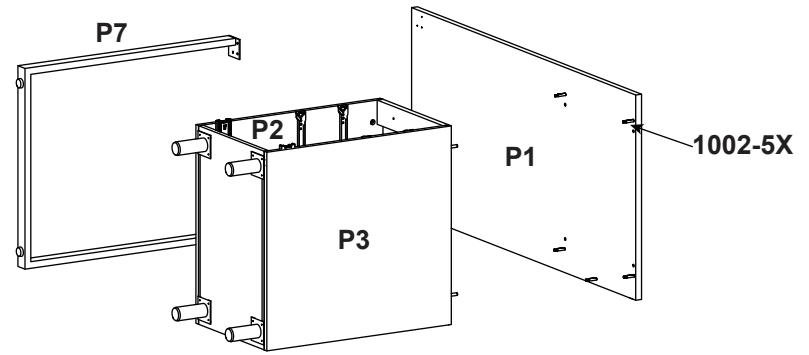

STEP:06

- A** Attach **P7** with **P1** Using 1004
Tools : Star Screw Driver
- B** Attach **P1** with **P1** Using Cam , Cam Pin, Dowel
Tools : Star Screw Driver
- C** Attach **P6** with **P1** Using 1007
Tools : Star Screw Driver

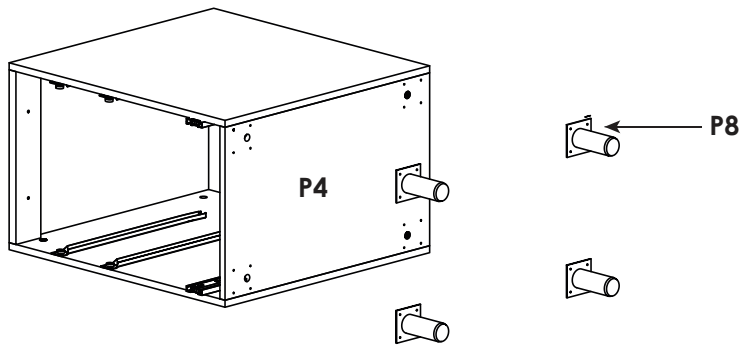

STEP:04

Attach P8 With P4
 Hardware : 1006
 Tools : Star Screw Driver

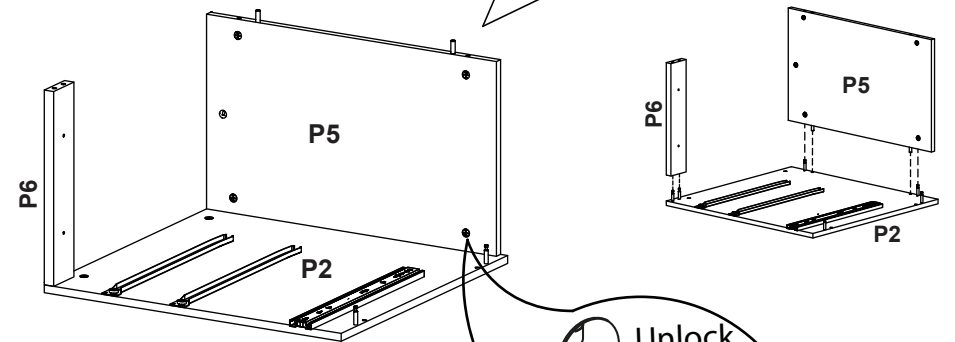
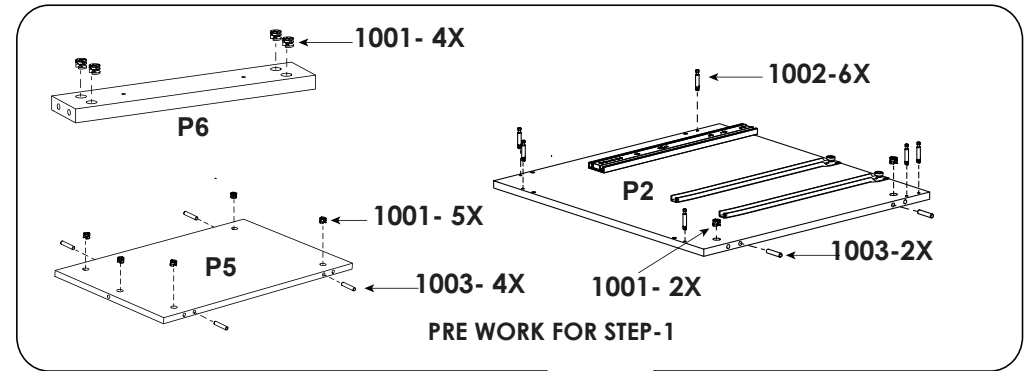
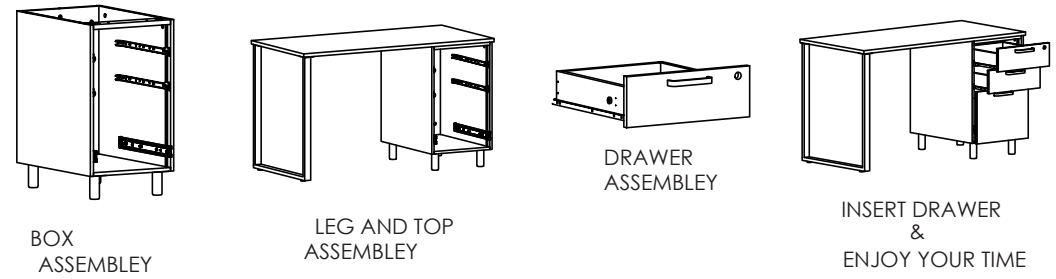
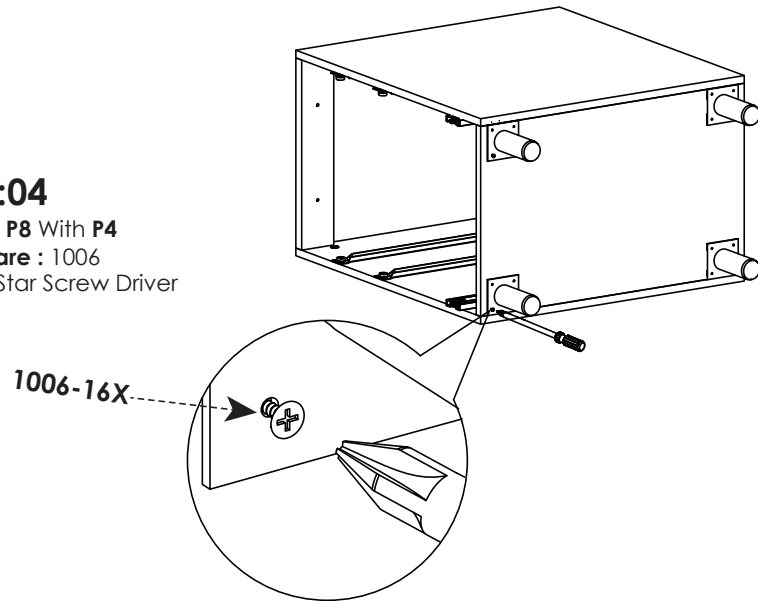

STEP:01

Attach P5, P6 With P5
 Hardware : 1001,1002,1003
 Tools : Flat/Star Screw Driver

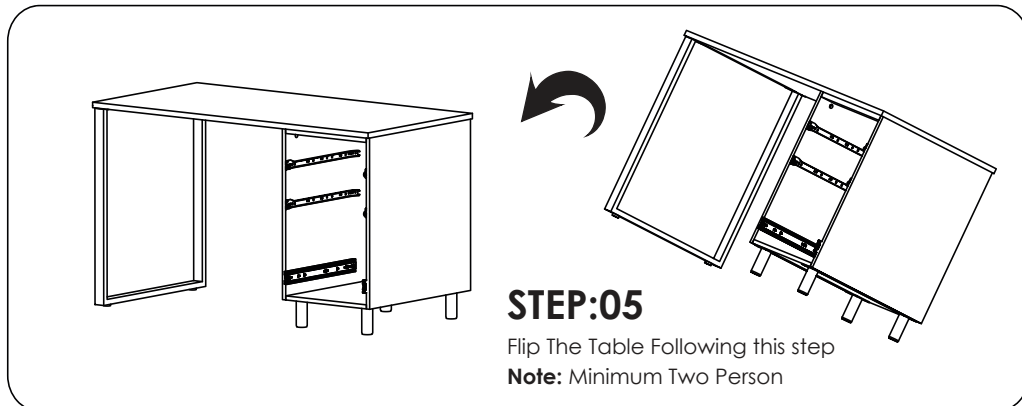
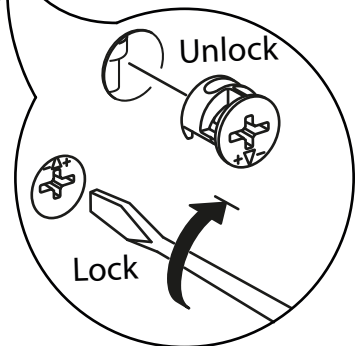

STEP:05

Flip The Table Following this step
 Note: Minimum Two Person

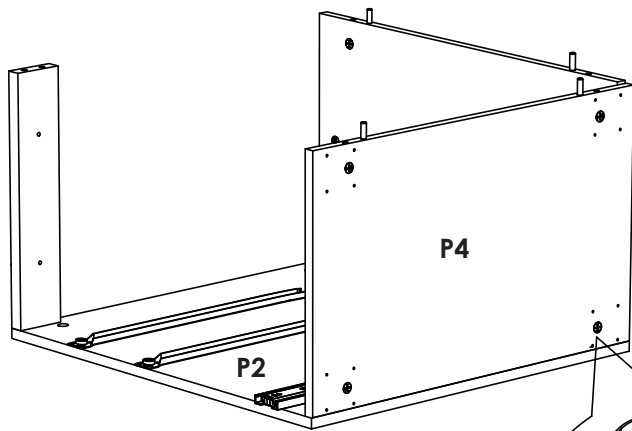
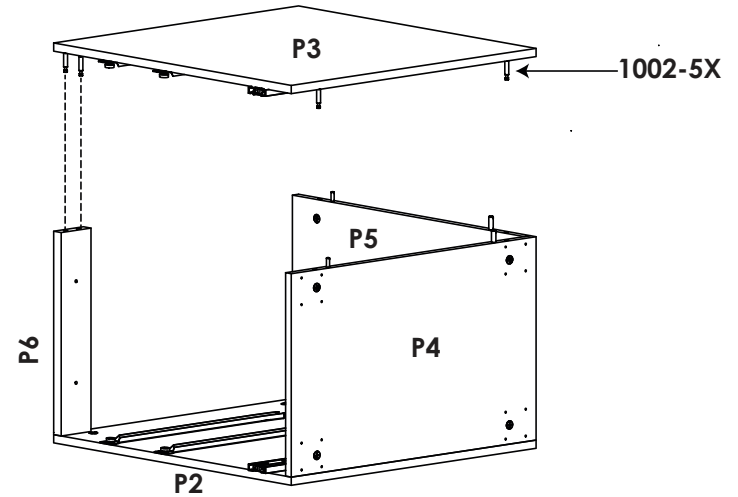
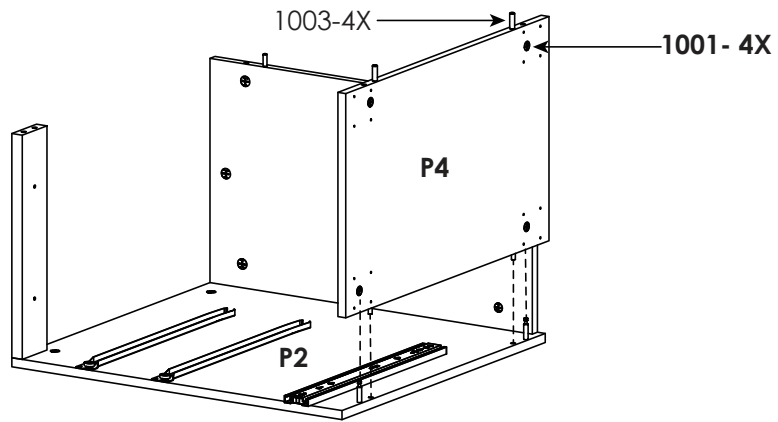

STEP:03

Attach **P3** With **P5,P4,P6**

Hardware : 1002,1003

Tools : Flat/Star Screw Driver

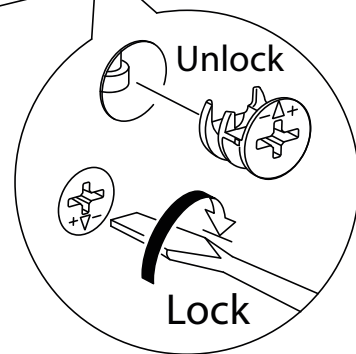

STEP:02

Attach **P4** With **P2**

Hardware : 1001,1003

Tools : Flat/Star Screw Driver

